

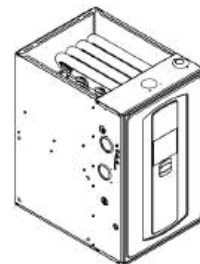

Installation, Operation, and Maintenance

Upflow/Horizontal and Dedicated Downflow Gas-Fired, Direct/Non-Direct Vent, Single Stage / Two Stage Condensing Furnaces with High Efficiency Motor

Upflow, Convertible to Horizontal Left and Horizontal Right Dedicated Downflow S9X1 S9X2 S9B1

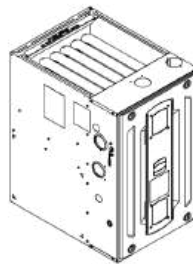

*Note: Graphics in this document are for representation only.
Actual model may differ in appearance.*



FNR-SVX002A-EN

⚠ SAFETY WARNING

Only qualified personnel should install and service the equipment. The installation, starting up, and servicing of heating, ventilating, and air-conditioning equipment can be hazardous and requires specific knowledge and training. Improperly installed, adjusted or altered equipment by an unqualified person could result in death or serious injury. When working on the equipment, observe all precautions in the literature and on the tags, stickers, and labels that are attached to the equipment.

Introduction

Read this manual thoroughly before operating or servicing this unit.

This document is customer property and is to remain with this unit. Return to the service information pack upon completion of work.

Warnings, Cautions, and Notices

Safety advisories appear throughout this manual as required. Your personal safety and the proper operation of this machine depend upon the strict observance of these precautions.

The three types of advisories are defined as follows:



Indicates a potentially hazardous situation which, if not avoided, could result in death or serious injury.



Indicates a potentially hazardous situation which, if not avoided, could result in minor or moderate injury. It could also be used to alert against unsafe practices.



Indicates a situation that could result in equipment or property-damage only accidents.

⚠ WARNING

Proper Field Wiring and Grounding Required!

Failure to follow code could result in death or serious injury.

All field wiring MUST be performed by qualified personnel. Improperly installed and grounded field wiring poses FIRE and ELECTROCUTION hazards. To avoid these hazards, you MUST follow requirements for field wiring installation and grounding as described in NEC and your local/state/national electrical codes.

⚠ WARNING

Personal Protective Equipment (PPE) Required!

Failure to wear proper PPE for the job being undertaken could result in death or serious injury.

Technicians, in order to protect themselves from potential electrical, mechanical, and chemical hazards, MUST follow precautions in this manual and on the tags, stickers, and labels, as well as the instructions below:

- **Before installing/servicing this unit, technicians MUST put on all PPE required for the work being undertaken (Examples; cut resistant gloves/sleeves, butyl gloves, safety glasses, hard hat/bump cap, fall protection, electrical PPE and arc flash clothing). ALWAYS refer to appropriate Safety Data Sheets (SDS) and OSHA guidelines for proper PPE.**
- **When working with or around hazardous chemicals, ALWAYS refer to the appropriate SDS and OSHA/GHS (Global Harmonized System of Classification and Labelling of Chemicals) guidelines for information on allowable personal exposure levels, proper respiratory protection and handling instructions.**
- **If there is a risk of energized electrical contact, arc, or flash, technicians MUST put on all PPE in accordance with OSHA, NFPA 70E, or other country-specific requirements for arc flash protection, PRIOR to servicing the unit. NEVER PERFORM ANY SWITCHING, DISCONNECTING, OR VOLTAGE TESTING WITHOUT PROPER ELECTRICAL PPE AND ARC FLASH CLOTHING. ENSURE ELECTRICAL METERS AND EQUIPMENT ARE PROPERLY RATED FOR INTENDED VOLTAGE.**

⚠ WARNING**Follow EHS Policies!**

Failure to follow instructions below could result in death or serious injury.

- All Tranepersonnel must follow the Environmental, Health and Safety (EHS) policies when performing work such as hot work, electrical, fall protection, and lockout/tagout. Where local regulations are more stringent than these policies, those regulations supersede these policies.
- Non-Tranepersonnel should always follow local regulations.

⚠ WARNING**Cancer and Reproductive Harm!**

This product can expose you to chemicals, including lead, which are known to the State of California to cause cancer and birth defects or other reproductive harm. For more information go to www.P65Warnings.ca.gov.

⚠ WARNING**Safety Hazard!**

Failure to follow instructions below could result in death or serious injury or property damage.

This unit is not to be used by persons (including children) with reduced physical, sensory, or mental capabilities, or lack of experience and knowledge, unless they have been given supervision or instruction concerning the use of the appliance by a person responsible for their safety.

Do not allow children to play or climb on the unit or to clean or maintain the unit without supervision.

⚠ WARNING**Fire Hazard!**

Failure to follow instructions below could result in death or serious injury or property damage.

For installations with flammable refrigeration system, the furnace must be powered at all times except during servicing. The furnace must be installed and connected according to installation instructions and wiring diagrams provided with the evaporator coil.

⚠ WARNING**Fire or Explosion Hazard!**

Failure to follow safety warnings exactly could result in a fire or explosion causing property damage, personal injury or loss of life.

Do not store or use gasoline or other flammable vapors and liquids in the vicinity of this or any other appliance. **WHAT TO DO IF YOU SMELL GAS:**

- Do not try to light any appliance.
- Do not touch any electrical switch; do not use any phone in your building.
- Immediately call your gas supplier from a neighbor's phone. Follow the gas supplier's instructions. If you cannot reach your gas supplier, call the fire department.
- Installation and service must be performed by a qualified installer, service agency, or the gas supplier.

⚠ WARNING**Explosion Hazard!**

Failure to follow instruction below could result in death or serious injury or property damage. Install a gas detector for leak warnings. The manufacturer does not test or endorse any specific brand or type of detector.

⚠ WARNING**Fire or Explosion Hazard!**

Failure to follow safety warnings exactly could result in serious injury, death, or property damage.

Never test for gas leaks with an open flame. Use a commercially available soap solution made specifically for the detection of leaks to check all connections. A fire or explosion can result causing property damage, personal injury, or loss of life.

⚠ WARNING**Electrical Shock, Fire, or Explosion Hazard!**

Failure to follow the safety warnings exactly could result in dangerous operation, serious injury, death, or property damage. Improper servicing could result in dangerous operation, serious injury, death, or property damage.

- Before servicing, disconnect all electrical power to the furnace.
- When servicing controls, label all wires prior to disconnecting. Reconnect wires correctly.
- Verify proper operation after servicing.

⚠ WARNING

Carbon Monoxide Poisoning!

Failure to follow instructions below could result in death or serious injury, or property damage.

- To confirm the furnace is vented properly, do not replace factory-supplied venting components with field fabricated parts. Fabricating parts can result in damaged vents and components, allowing carbon monoxide to escape the venting system.
- Follow the service and/or periodic maintenance and installation and operation instructions for the furnace and the venting system. Do not attempt to change the venting system.
- Verify the blower door is in place and not ajar. Dangerous fumes could escape an improperly secured door.
- Inspect the chimney liner thoroughly to verify no cracks or other potential areas for flue gas leaks are present in the liner. Liner leaks will result in early damage to the chimney. Furnace venting into an unlined masonry chimney or concrete chimney is prohibited.

⚠ WARNING

Carbon Monoxide Poisoning!

Failure to follow instructions below could cause result in death or serious injury, or property damage. Follow the installation and operation instructions for the venting system. Do not attempt to change the venting system.

⚠ WARNING

Fire Hazard!

Failure to follow instructions below could result in death or serious injury or property damage. Do not install the furnace directly on carpet, tile, or other combustible material other than wood flooring. Use subbase (BAYBASE205) between the furnace and combustible flooring for vertical downflow applications. When the downflow furnace is installed vertically with a cased coil, a subbase is not required.

⚠ WARNING

Explosion Hazard!

Failure to follow instruction below could result in death or serious injury or property damage. Propane gas is heavier than air and can accumulate in low areas or confined spaces. Odorant fade may make it undetectable without a warning device. If a gas furnace is installed in a basement, excavated areas, or a confined space, it is strongly recommended to contact a gas supplier to install a gas detector for leak warnings. The manufacturer does not test or endorse any specific brand or type of detector.

⚠ WARNING

Electrical Shock Hazard!

Failure to follow instructions below could result in death or serious injury or property damage. Do not bypass the door switch or the panel loop permanently.

⚠ WARNING

Electrical Shock Hazard!

Failure to follow instructions below could result in death or serious injury or property damage.. Do not touch any components other than the Menu and Option buttons on IFC when setting up the system or during fault code recovery.

⚠ WARNING

Risk of Fire or Explosion!

Failure to follow instruction below could result in death or serious injury or property damage. Do NOT attempt to manually light the furnace.

⚠ WARNING

Electrical Shock Hazard!

Failure to follow instructions below could result in death or serious injury or property damage. Disconnect power to the unit before removing the blower door and wait at least 10 seconds for the IFC power supply to discharge to 0 volts.

⚠ WARNING

Safety Hazard!

Failure to follow instructions below could result in death or serious injury or property damage. These furnaces are not approved or intended for installation in trailers or recreational vehicles. Installation in manufactured (mobile) housing is only approved with BAYMFGH Kit.

⚠ WARNING

Explosion Hazard!

Failure to follow instruction below could result in death or serious injury or property damage. If electrical, fuel, or mechanical failures occur, shut off the gas supply at the manual valve on the supply piping before turning off the furnace's electrical power. Contact your dealer's designated service agency.

⚠ WARNING**Safety Hazard!**

Failure to follow instructions below could result in death or serious injury or property damage. Do not use semi-rigid metallic gas connectors (flexible gas lines) within the furnace cabinet.

⚠ WARNING**High Voltage Moving Parts!**

Failure to follow instructions below could result in death or serious injury or property damage due to high voltage electrical components, fast-moving fans, and combustible gas. During installation and servicing, turn off the main gas valve and disconnect the electrical supply. If operating checks must be performed with the unit operating, the technician must recognize these hazards and proceed safely.

⚠ WARNING**Safety Hazard!**

Failure to follow instructions below could result in death or serious injury or property damage. Do not install the filter in the return duct directly above the furnace in horizontal applications. Install the filter remotely.

⚠ WARNING**Safety Hazard!**

Failure to follow instructions below could result in death or serious injury or property damage. Turn off the power to the furnace before servicing filters to avoid contact with moving parts.

⚠ WARNING**Shock Hazard!**

Failure to follow instructions below could result in death or serious injury or property damage. If a disconnect switch is present, always lock in the open position before servicing the unit.

⚠ WARNING**Electrical Shock Hazard!**

Failure to follow this warning could result in an electric shock, fire, injury, or death. Ensure cabinet has an uninterrupted or unbroken ground in accordance with National Electrical Code, ANSI/NFPA 70 – latest edition and Canadian Electrical Code, CSA C22.1 or local codes in case of an electrical fault.

⚠ WARNING**Overheating and Explosion Hazard!**

Failure to follow this warning could result in property damage, personal injury, or death. Should the gas supply fail to shut off or if overheating occurs, shut off the gas valve to the furnace before shutting off the electrical supply.

⚠ WARNING**Safety Hazard!**

Failure to follow instructions below could result in death or serious injury or property damage. The vent for this appliance must not terminate over public walkways, near soffit or crawl space vents, or where condensate could cause damage or be detrimental to the operation of regulators, relief valves, or other equipment.

⚠ WARNING**Hot Surface!**

Failure to follow instructions below could result in minor to moderate injuries. Do not touch igniter. It is extremely hot.

⚠ WARNING

Carbon Monoxide Poisoning Hazard!

Failure to follow the steps outlined below for each appliance connected to the venting system being placed into operation could result in carbon monoxide poisoning or death.

The following steps shall be followed for each appliance connected to the venting system being placed into operation, while all other appliances connected to the venting system are not in operation:

- Seal any unused openings in the venting system.
- Inspect the venting system for proper size and horizontal pitch as required in the National Fuel Gas Code, ANSI Z223.1/NFPA 54 or the Natural Gas and Propane Installation Code, CSA B149.1 and these instructions. Determine there is no blockage or restriction, leakage, corrosion, or other deficiencies which could cause an unsafe condition.
- As far as practical, close all building doors and windows and all doors between the space in which the appliance(s) connected to the venting system are located and other spaces of the building.
- Close fireplacedampers.
- Turn on clothes dryers and any appliance not connected to the venting system. Turn on any exhaust fans, such as range hoods and bathroom exhausts, so they are operating at maximum speed. Do not operate a summer exhaust fan.
- Follow the lighting instructions. Place the appliance being inspected into operation. Adjust the thermostat so appliance is operating continuously.
- Test for spillage from draft hood equipped appliances at the draft hood relief opening after 5 minutes of main burner operation. Use the flame of a match or candle.
- If improper venting is observed during any of the above tests, correct the venting system in accordance with the National Fuel Gas Code, ANSI Z223.1/NFPA and/or Natural Gas and Propane Installation Code, CSA B149.1 .
- After it has been determined that each appliance connected to the venting system properly vents when tested as outlined above, return doors, windows, exhaust fans, fireplace dampers, and any other gas-fired burning appliance to their previous conditions of use.

⚠ CAUTION

Improper Voltage Connection!

Failure to follow instructions below could result in personal injury or equipment damage. Do NOT connect the furnace line voltage to a GFCI-protected circuit.

⚠ CAUTION

Corrosion Hazard!

Failure to follow instructions below could result in minor to moderate injury or property damage. Do not install the furnace in a corrosive or contaminated atmosphere.

⚠ CAUTION

Sharp Edges!

Failure to follow instructions below could result in minor to moderate injury. The service procedure described in this document involves working around sharp edges. To avoid being cut, technicians MUST put on all necessary Personal Protective Equipment (PPE), including gloves and arm guards.

⚠ CAUTION

Valve Damage!

Failure to follow instructions below could result in minor to moderate injury or equipment damage. Use a backup wrench on the gas valve when installing gas piping to prevent damage to the valve and manifold assembly.

⚠ CAUTION

Freeze Damage!

Failure to follow instructions below could result in minor to moderate injury or property damage. Insulate vent pipes with 1/2 inch (12.7 mm) Armaflex-type insulation or equivalent when passing through unheated spaces exposed to freezing temperatures. Insulation is not needed if the space is heated enough to prevent freezing. If domestic water pipes are not protected from freezing, the space is considered heated. Schedule qualified personnel to inspect the temperature if the house is vacant during freezing weather. A furnace failure could lead to frozen water pipes.

⚠ CAUTION

Freeze Damage!

Failure to follow instructions below could result in minor to moderate injury or property damage. Take measures to prevent drains from freezing or causing slippery conditions. Excessive draining of condensate may cause saturated ground conditions that may result in damage to plants.

⚠ CAUTION

Ignition Function!

Failure to follow instructions below could result in minor to severe injury and result in poor ignition characteristics.
Maintain manifold pressure in high altitude installations.

⚠ CAUTION

Water Damage!

Failure to follow instructions below could result in minor to moderate injury or property damage.
Install an external overflow drain pan in all applications over a finished ceiling to prevent leaking condensate.

⚠ CAUTION

FURNACE SERVICE CAUTION!

Failure to follow instructions below could result in property damage or personal injury.
Label all wires prior to disconnection when servicing controls. Verify proper operation after servicing.
Wiring errors can cause improper and dangerous operation.

⚠ CAUTION

Do NOT Use as Construction Heater!

Failure to follow instructions below could result in property damage or personal injury.
To prevent shortening its service life, do not use the furnace as a construction heater during the finishing phases of construction until the furnace installation guidelines are met. Condensate in the presence of chlorides and fluorides from paint, varnish, stains, adhesives, cleaning compounds, and cement, create a corrosive condition which may cause rapid deterioration of the heat exchanger.

⚠ CAUTION

Wiring Hazard!

Failure to follow instructions below could result in minor to moderate injury or property damage.
The integrated furnace control is polarity sensitive. Connect the hot leg of the 120 VAC power to the black field lead.

⚠ CAUTION

Venting Required!

Failure to follow instructions below could result in minor to moderate injury or property damage.
• Condensing furnaces may be vented through unused chimneys. Do not vent through chimneys used for wood-burning, oil furnaces, incinerators or any other gas appliance. If remaining free area between single wall flue pipe and masonry chimney is used for another gas appliance, venting area must be sufficient and that appliance must be connected to the chimney with separate entry openings.
• The single wall flue pipe joints must be sealed. The 90° elbow connection to the vertical pipe must be sealed to prevent condensate leakage to base of the masonry chimney.

⚠ CAUTION

Coil Requirement!

Failure to follow instructions below could result in minor to moderate injury or property damage.
For 4GXC* and 4MXC* coils on upflow furnaces in vertical, horizontal left, or horizontal right orientations without a factory-installed metal drain pan shield, must use a MAY*FERCOLKITAA kit. Coils installed on upflow furnaces must have drain pans suitable for 400° F (205° C) or metal drain pan shield. Downflow furnaces do not require a metal drain pan shield or MAY*FERCOLKITAA kit.

NOTICE

Equipment Damage!

Failure to follow instructions below could result in equipment damage.
UV light exposure can deteriorate plastic blower material, potentially damaging the blower housing.
For units with plastic blower housings, do not install third-party UV air cleaners where the blower housing is exposed to UV light.

For more information, visit www.trane.com and www.americanstandardair.com or contact your installing dealer.
6200 Troup Highway
Tyler, TX 75707

Copyright

This document and the information in it are the property of Trane, and may not be used or reproduced in whole or in part without written permission. Trane reserves the right to revise this publication at any time, and to make changes to its content without obligation to notify any person of such revision or change.

Trademark

All trademarks referenced in this document are the trademarks of their respective owners.

Revision History

- Replaced S9XB-SVX001-1D-EN with a new literature number – FNR-SVX002A-EN .
- Updated the product specifications, 1st/2nd stage heating CFM/temperature rise, general installation, supply duct connections, and field wiring content.
- Added information on factory set up - upflow and downflow orientation.
- Updated the Troubleshooting chapter.
- Updated furnace orientation in supply duct connections.
- Updated the twinning information.

Table of Contents

Accessories.....	10	Condensate Drain Instructions	69
DocumentPackContents.....	11	Vertical Applications	69
PartList.....	11	HorizontalApplications.....	73
ProductSpecifications.....	12	General Start-Up and Adjustment.	74
Furnace Installation Guidelines	22	Preliminary Inspections.	74
Safety Practices and Precautions	22	LightingInstructions.....	74
GeneralGuidelines.....	22	Control and Safety Switch Adjustment	74
Locations and Clearances	23	LimitSwitchCheckOut.....	74
DimensionalData.....	24	Furnace Combustion Air Exhaust	
WiringDiagrams.....	26	Options.....	75
AirflowTables.....	32	Factory Set Up - Upflow and Downflow	
CFM Versus Temperature Rise	35	Orientation.....	76
Furnace General Installation	37	Upflow Furnace in Upflow Position - Top	
Horizontal Installation in an Attic or		VentedCombustionAir.....	76
Crawlspace.....	37	Upflow Position - Left Side Vented	
Horizontal Installation Hanging Using		CombustionAir.....	77
Straps	37	Horizontal Left Position - Side Vented	
GasPiping.....	37	CombustionAir.....	80
Combustion and Input Check	39	Furnace in Horizontal Left Position - Top	
GasValveAdjustment.....	40	VentedCombustionAir.....	83
HighAltitudeDerate.....	41	Furnace in Horizontal Right Position - Top	
GeneralVenting.....	42	VentedCombustionAir.....	86
3-Inch Venting Requirements	43	Furnace in Horizontal Right Position - Left	
TypicalVenting.....	43	VentedCombustionAir.....	89
SpecialCaseVenting.....	44	Downflow Furnace - Top Vented	
VentTerminations.....	45	CombustionAir.....	93
AttachingVentPiping.....	46	Downflow Furnace - Left Side Vented	
Maximum Vent Length Table	48	CombustionAir.....	94
HorizontalVenting.....	49	Integrated Furnace Control Menu.	98
Horizontal Venting Through Wall with		SettingAirflow.....	103
ConcentricVentKit.....	51	Integrated Furnace Control Display	
VentingthroughtheRoof.....	54	Codes	104
DownwardVenting.....	56	FaultCodeRecovery.....	105
Air for Combustion and Ventilation	56	Troubleshooting.....	106
DuctConnections.....	58	BellyBandLocation.....	119
Supply Duct Connections	58	SequenceofOperation.....	121
Return Duct Connections	60	Periodic Servicing Requirements	123
ReturnAirFilters.....	63		
ElectricalConnections.....	64		
FieldWiring.....	65		
Twinning.....	67		

Accessories

Table 1. Accessories

Model Number	Description	Use with
MAYBFERCOLKITA	Heat Shield Kit for B-sidith 4GXCB or 4MCXB Coils	B width 4GXCB or 4MCXB Coils when installed with Upflow Furnace in all orientations.
MAYCFERCOLKITA	Heat Shield Kit for C-sidith 4GXCC or 4MCXC Coils	C width 4GXCC or 4MCXC Coils when installed with Upflow Furnace in all orientations.
MAYDFERCOLKITA	Heat Shield Kit for D-sidith 4GXCD or 4MCXD Coils	D width 4GXCD or 4MCXD Coils when installed with Upflow Furnace in all orientations. All Upflow Furnaces
BAYHANG	Horizontal Hanging Kit	All Furnaces All Furnaces
BAYVENT200B	Sidewall Vent Termination Kit	All Furnaces
BAYVENTCN200B	Sidewall Vent Termination Kit (Canada - CPVC)	All Furnaces
BAYAIR30AVENTA	Concentric Vent Kit	All Furnaces
BAYAIR30CNVENT	Concentric Vent Kit (Canada - CPVC)	B Cabinet Upflow Furnaces
BAYREDUCE	Reducing Coupling (Canada - CPVC)	C Cabinet Upflow Furnaces
BAYLIFTB(a)	Dual Return Kit (B size extension)	D Cabinet Upflow Furnaces
BAYLIFTC(a)	Dual Return Kit (C size extension)	All Downflow Furnaces
BAYLIFTD(a)	Dual Return Kit (D size extension)	B Cabinet Furnaces in Downflow/Horizontal
BAYBASE205	Downflow Subbase	C Cabinet Furnaces in Downflow/Horizontal
BAYFLTR203	Horizontal Filter Kit	D Cabinet Furnaces in Downflow Horizontal
BAYFLTR204	Horizontal Filter Kit	All Downflow Furnaces
BAYFLTR205	Horizontal Filter Kit	All Upflow Furnaces All Furnaces(c)
BAYFLTR206	Filter Access Door Kit (Downflow only)	BAYSF1255(b)
BAYSF1165(a) (b)	1-in SlimFit Cabinet with MERV 4 Filter	All Furnaces
BAYSF1255(b)	1-in SlimFit Rack with MERV 4 Filter	All Upflow Furnaces - Special Case
FLRSF1255	1-in Filter Replacement (Qty 12)	All Furnaces
BAYLPSS400(b)	Propane Conversion Kit with Stainless Steel Burners	All Furnaces
BAYBURNERSS	All Stainless Steel Natural Gas Burners - Set of Six	
BAYMFGH200B	Manufactured/Mobile Housing Kit	
BAYCNDTRAP2A	Inline Condensate Trap Kit used with Special Venting on 2-in Vent Pipe Inline Condensate Trap Kit used with Special Venting on 3-in	
BAYCNDTRAP3A	Vent Pipe	All Furnaces

^(a) Airflow greater than 1600 CFM, Furnace will require air openings and filters on: (1) both sides, (2) one side and the bottom, or (3) just on the bottom.

^(b) Latest revision.

^(c) Designed to fit all S-Series furnaces with or without transition when used in side return. Fits B width cabinet without a transition in upflow/downflow application.

Document Pack Contents

Table 2. Document pack contents

Item	Qty.	Description
1	1	Condensate Drain Tube Assembly
2	1	Inlet Vent (2-in. - ADP01586 and 3-in. - ADP01587)(a)
3	1	Inlet Vent Gasket
4	1	Outlet Vent Assembly
5	1	Outlet Vent Gasket
6	6	Screws
7	1	Condensate Trap Grommet
8	1	Plug — Condensate/Gas
9	1	Plug — Electrical
10	2	Grommet — Condensate/Gas
11	1	Installation, Operation, and Maintenance
12	1	Owner Guide
13	1	Limited Warranty
14	1	2 to 3-in. Coupling — CPL01544 (b)
6	2	Note: Tinnerman Clips should be kept with unit and are used if the door panel flange hole(s) becomes stripped.

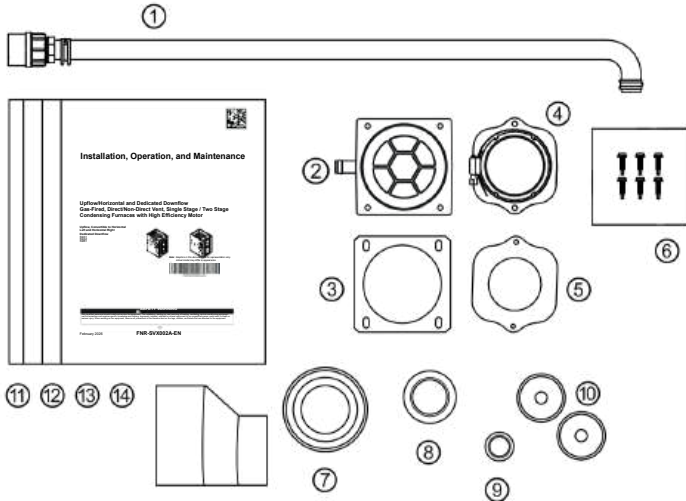

(a) 3-in. inlet vent supplied with S9X1D120U, S9X1D120D, S9X2D120U, S9X2D120D, S9B1D120U, and S9B1D120D only. 2-in. inlet vent supplied with all other models.
 (b) Supplied with S9X1D120U, S9X1D120D, S9X2D120U, S9X2D120D, S9B1D120U, and S9B1D120D only

Part List

Table 3. Part list

<ul style="list-style-type: none"> • Igniter • Flame Sensor • In-shot Burner(s) • Gas Valve 	<ul style="list-style-type: none"> • Inducer Assembly • Blower Motor • Blower Wheel • IFC (Integrated Furnace Control) 	<ul style="list-style-type: none"> • Pressure Switch(es) • Main Thermal Limit • Roll-Out Switch(es) • Reverse Air Switch(es)
---	--	--

Product Specifications

Table 4. Models S9X1B040U3PSBB, S9X1B060U4PSBB, S9X1B080U4PSBB, S9X1C080U5PSBB, S9B1B040U3PSAB, S9B1B060U4PSAB, S9B1B080U4PSAB, and S9B1C080U5PSAB

Model Number	S9X1B040-U3PSBB	S9B1B040-U3PSAB	S9X1B060-U4PSBB	S9B1B060-U4PSAB	S9X1B080-U4PSBB	S9B1B080-U4PSAB	S9X1C080-U5PSBB	S9B1C080-U5PSAB
Type	Upflow / Horizontal		Upflow / Horizontal		Upflow / Horizontal		Upflow / Horizontal	
Ratings ^(a)								
Input BTUH	40,000		60,000		80,000		80,000	
Capacity BTUH (ICS) ^(b) ^(c)	39,000		58,300		77,200		77,800	
Temp. Rise (Min. - Max.) °F	30 - 60		30 - 60		45 - 75		40-70	
AFUE (%) ^(c)	96.0	92.1	96.0	92.1	96.0	92.1	96.0	92.1
Return Air Temp. (Min.- Max.)	45°F - 80°F		45°F - 80°F		45°F - 80°F		45°F - 80°F	
CEE Tier	2	1	2	1	2	1	2	1
Energy Star Rated Region Before July 31, 2026	US - All/ Canada	US-South	US - All/ Canada	US-South	US - All/ Canada	US-South	US - All/ Canada	US-South
Energy Star Rated Region On or After July 31, 2026	US - South	N/A	US - South	N/A	US - South	N/A	US - South	N/A
Energy Star Orientation	Upflow / Horizontal		Upflow / Horizontal		Upflow / Horizontal		Upflow / Horizontal	
Integrated Furnace Control								
Input-Communication Protocol	24 Volts		24 Volts		24 Volts		24 Volts	
Blower Drive	DIRECT		DIRECT		DIRECT		DIRECT	
Diameter - Width (in.)	11X8		11X8		11X8		11 X 10	
No. Used	1		1		1		1	
Speeds (No.) ^(d)	9		9		9		9	
CFM vs. iwc.	See Fan Performance Table		See Fan Performance Table		See Fan Performance Table		See Fan Performance Table	
Motor HP	0.5		0.8		0.8		1.0	
R.P.M.	1075		1075		1075		1075	
Volts / Ph / Hz	120/1/60		120/1/60		120/1/60		120/1/60	
FLA	6.4		8.4		8.4		10.6	
Combustion Fan - Type	Centrifugal		Centrifugal		Centrifugal		Centrifugal	
Drive - No. Speeds	Direct - 1		Direct - 1		Direct - 1		Direct - 1	
Motor RPM	3300		3300		3300		3300	
Volts/Ph/Hz	120/1/60		120/1/60		120/1/60		120/1/60	
FLA	2.1		2.1		2.1		0.7	
Filter - Furnished?	No		No		No		No	
Type Recommended	High Velocity		High Velocity		High Velocity		High Velocity	
Hi Vel. (No.-Size-Thk.)	1-16X25-1in.		1-16X25-1in.		1-16X25-1in.		1-20X25-1in.	

Table 4. Models S9X1B040U3PSBB, S9X1B060U4PSBB, S9X1B080U4PSBB, S9X1C080U5PSBB, S9B1B040U3PSAB, S9B1B060U4PSAB, S9B1B080U4PSAB, and S9B1C080U5PSAB (continued)

Model Number	S9X1B040-U3PSBB	S9B1B040-U3PSAB	S9X1B060-U4PSBB	S9B1B060-U4PSAB	S9X1B080-U4PSBB	S9B1B080-U4PSAB	S9X1C080-U5PSBB	S9B1C080-U5PSAB
Vent Pipe Diameter - Min. (in.) (e) (f)	2 Round		2 Round		2 Round		2 Round	
Heat Exchanger Type								
Fired	409 Stainless Steel		409 Stainless Steel		409 Stainless Steel		409 Stainless Steel	
Unfired	29-4C Stainless Steel		29-4C Stainless Steel		29-4C Stainless Steel		29-4C Stainless Steel	
Gauge (Fired)	20		20		20		20	
Orifices - Main								
Nat. Gas Qty. - Drill Size	2-45		3-45		4-45		4-45	
Propane Gas Qty. - Drill Size	2-56		3-56		4-56		4-56	
Gas Valve	Redundant - One Stage		Redundant - One Stage		Redundant - One Stage		Redundant - One Stage	
Pilot Safety Device	Redundant - One Stage		Redundant - One Stage		Redundant - One Stage		Redundant - One Stage	
Type	120 V SiNi Igniter		120 V SiNi Igniter		120 V SiNi Igniter		120 V SiNi Igniter	
Burners - Type	Multiport Inshot		Multiport Inshot		Multiport Inshot		Multiport Inshot	
Number	2		3		4		4	
Power Conn. - V/Ph/Hz (g)	120/1/60		120/1/60		120/1/60		120/1/60	
Ampacity (Amps)	10.3		12.8		12.8		14.1	
Max. Overcurrent Protection (Amps)	15		15		15		15	
Pipe Conn. Size (in.)	1/2		1/2		1/2		1/2	

- (a) For U.S. applications, above input ratings (BTUH) are up to 2,000 feet, derate 4% per 1,000 feet for elevations above 2,000 feet above sea level. For Canadian applications, above input ratings (BTUH) are up to 4,500 feet, derate 4% per 1,000 feet for elevations above 4,500 feet above sea level.
- (b) Central Furnace heating designs are certified to ANSI Z21.47 / CSA 2.3 — latest edition.
- (c) Based on U.S. government standard tests.
- (d) 9 Speed constant torque ECM blower motor.
- (e) See the [Maximum Vent Length Table](#), p. 48 in this document.
- (f) All furnace models have a vent outlet diameter that equals 2 in.
- (g) The above wiring specifications are in accordance with National Electrical Code; however, installations must comply with local codes.

Table 5. Models S9X1C100U5PSBB, S9X1D120U5PSBB, S9X1B040D3PSBB, S9X1B060D3PSBB, S9B1C100U5PSAB, S9B1D120U5PSAB, S9B1B040D3PSAB, and S9B1B060D3PSAB

Model Number	S9X1C100-U5PSBB	S9B1C100-U5PSAB	S9X1D120-U5PSBB	S9B1D120-U5PSAB	S9X1B040-D3PSBB	S9B1B040-D3PSAB	S9X1B060-D3PSBB	S9B1B060-D3PSAB
Type	Upflow / Horizontal		Upflow / Horizontal		Downflow		Downflow	
Ratings (a)								
Input BTUH	100,000		120,000		40,000		60,000	
Capacity BTUH (ICS) (b) (c)	97,400		113,400		38,900		57,600	
Temp. Rise (Min. - Max.) °F	40 - 70		40 - 70		30 - 60		35 - 65	
AFUE (%)	95.0	92.1	95.0	92.1	96.0	92.1	96.0	92.1
Return Air Temp. (Min.-Max.)	45°F - 80°F		45°F - 80°F		45°F - 80°F		45°F - 80°F	
GEE Tier	2	1	2	1	2	1	2	1

Product Specifications

Table 5. Models S9X1C100U5PSBB, S9X1D120U5PSBB, S9X1B040D3PSBB, S9X1B060D3PSBB, S9B1C100U5PSAB, S9B1D120U5PSAB, S9B1B040D3PSAB, and S9B1B060D3PSAB (continued)

Model Number	S9X1C100-U5PSBB	S9B1C100-U5PSAB	S9X1D120-U5PSBB	S9B1D120-U5PSAB	S9X1B040-D3PSBB	S9B1B040-D3PSAB	S9X1B060-D3PSBB	S9B1B060-D3PSAB
Energy Star Rated Region Before July 31, 2026	US - All / Canada	US - South	US - All / Canada	US - South	US - All / Canada	US - South	US - All / Canada	US - South
Energy Star Rated Region On or After July 31, 2026	US - South	N/A	US - South	N/A	US - South	N/A	US - South	N/A
Energy Star Orientation	Upflow / Horizontal		Upflow / Horizontal		Downflow		Downflow	
Integrated Furnace Control								
Input-Communication Protocol	24 Volts		24 Volts		24 Volts		24 Volts	
Blower Drive	DIRECT		DIRECT		DIRECT		DIRECT	
Diameter - Width (in.)	11 X 10		11 X 10		11X8		11X8	
No. Used	1		1		1		1	
Speeds (No.) (d)	9		9		9		9	
CFM vs. iwc.	See Fan Performance Table		See Fan Performance Table		See Fan Performance Table		See Fan Performance Table	
Motor HP	1.0		1.0		0.5		0.5	
R.P.M.	1075		1075		1075		1075	
Volts / Ph / Hz	120/1/60		120/1/60		120/1/60		120/1/60	
FLA	10.6		10.6		6.4		6.4	
Combustion Fan - Type	Centrifugal		Centrifugal		Centrifugal		Centrifugal	
Drive - No. Speeds	Direct - 1		Direct - 1		Direct - 1		Direct - 1	
Motor RPM	3300		3300		3300		3300	
Volts/Ph/Hz	120/1/60		120/1/60		120/1/60		120/1/60	
FLA	0.7		0.7		2.1		2.1	
Filter - Furnished?	No		No		No		No	
Type Recommended	High Velocity		High Velocity		High Velocity		High Velocity	
Hi Vel. (No.-Size-Thk.)	1-20X25-1in.		1-24X25-1in.		1-16X25-1in.		1-16X25-1in.	
Vent Pipe Diameter - Min. (in.) (e) (f)	2 Round		3 Round		2 Round		2 Round	
Heat Exchanger Type	2 Round		3 Round		2 Round		2 Round	
Fired	409 Stainless Steel		409 Stainless Steel		409 Stainless Steel		409 Stainless Steel	
Unfired	29-4C Stainless Steel		29-4C Stainless Steel		29-4C Stainless Steel		29-4C Stainless Steel	
Gauge (Fired)	20		20		20		20	
Orifices - Main								
Nat. Gas Qty. - Drill Size	5-45		6-45		2-45		3-45	
Propane Gas Qty. - Drill Size	5-56		6-56		2-56		3-56	
Gas Valve	Redundant - One Stage		Redundant - One Stage		Redundant - One Stage		Redundant - One Stage	
Pilot Safety Device	Redundant - One Stage		Redundant - One Stage		Redundant - One Stage		Redundant - One Stage	
Type	120 V SiNi Igniter		120 V SiNi Igniter		120 V SiNi Igniter		120 V SiNi Igniter	

Table 5. Models S9X1C100U5PSBB, S9X1D120U5PSBB, S9X1B040D3PSBB, S9X1B060D3PSBB, S9B1C100U5PSAB, S9B1D120U5PSAB, S9B1B040D3PSAB, and S9B1B060D3PSAB (continued)

Model Number	S9X1C100-U5PSBB	S9B1C100-U5PSAB	S9X1D120-U5PSBB	S9B1D120-U5PSAB	S9X1B040-D3PSBB	S9B1B040-D3PSAB	S9X1B060-D3PSBB	S9B1B060-D3PSAB
Burners - Type	Multiport Inshot		Multiport Inshot		Multiport Inshot		Multiport Inshot	
Number	5		6		2		3	
Power Conn. - V/Ph/Hz (g)	120/1/60		120/1/60		120/1/60		120/1/60	
Ampacity (Amps)	14.1		14.1		10.3		10.3	
Max. Overcurrent Protection (Amps)	15		15		15		15	
Pipe Conn. Size (in.)	1/2		1/2		1/2		1/2	

- (a) For U.S. applications, above input ratings (BTUH) are up to 2,000 feet, derate 4% per 1,000 feet for elevations above 2,000 feet above sea level. For Canadian applications, above input ratings (BTUH) are up to 4,500 feet, derate 4% per 1,000 feet for elevations above 4,500 feet above sea level.
- (b) Central Furnace heating designs are certified to ANSI Z21.47 / CSA 2.3 — latest edition.
- (c) Based on U.S. government standard tests.
- (d) 9 Speed constant torque ECM blower motor.
- (e) See the [Maximum Vent Length Table, p. 48](#) in this document.
- (f) All furnace models have a vent outlet diameter that equals 2 in.
- (g) The above wiring specifications are in accordance with National Electrical Code; however, installations must comply with local codes.

Table 6. Models S9X1B080D4PSBB, S9X1C100D5PSBB, S9X1D120D5PSBB, S9B1B080D4PSAB, S9B1C100D5PSAB, and S9B1D120D5PSAB

Model Number	S9X1B080D4P-SBB	S9B1B080D4P-SAB	S9X1C100D5P-SBB	S9B1C100D5P-SAB	S9X1D120D5P-SBB	S9B1D120D5P-SAB
Type	Downflow		Downflow		Downflow	
Ratings (a)						
Input BTUH	80,000		100,000		120,000	
Capacity BTUH (ICS) (b) (c)	76,900		96,800		115,500	
Temp. Rise (Min. - Max.) °F	45-75		40-70		45-75	
AFUE (%) (c)	95.0	92.1	96.0	92.1	95.0	92.1
Return Air Temp. (Min.-Max.)	45°F - 80°F		45°F - 80°F		45°F - 80°F	
CEE Tier	2	1	2	1	2	1
Energy Star Rated Region Before July 31, 2026	US-All/Canada	US-South	US-All/Canada	US-South	US-All/Canada	US-South
Energy Star Rated Region On or After July 31, 2026	US - South	N/A	US - South	N/A	US - South	N/A
Energy Star Orientation						
Integrated Furnace Control	Downflow		Downflow		Downflow	
Input-Communication Protocol						
Blower Drive						
	24 Volts		24 Volts		24 Volts	
	DIRECT		DIRECT		DIRECT	
Diameter - Width (in.)	11X8		11 X 10		11 X 10	
No. Used	1		1		1	
Speeds (No.) (d)	9		9		9	
CFM vs. iwc.	See Fan Performance Table		See Fan Performance Table		See Fan Performance Table	
Motor HP	0.8		1.0		1.0	
R.P.M.	1075		1075		1075	

Product Specifications

Table 6. Models S9X1B080D4PSBB, S9X1C100D5PSBB, S9X1D120D5PSBB, S9B1B080D4PSAB, S9B1C100D5PSAB, and S9B1D120D5PSAB (continued)

Model Number	S9X1B080D4P-SBB	S9B1B080D4P-SAB	S9X1C100D5P-SBB	S9B1C100D5P-SAB	S9X1D120D5P-SBB	S9B1D120D5P-SAB
Volts / Ph / Hz	120/1/60		120/1/60		120/1/60	
FLA	9.3		10.6		10.6	
Combustion Fan - Type	Centrifugal		Centrifugal		Centrifugal	
Drive - No. Speeds	Direct - 1		Direct - 1		Direct - 1	
Motor RPM	3300		3300		3300	
Volts/Ph/Hz	120/1/60		120/1/60		120/1/60	
FLA	2.1		0.7		0.7	
FILTER - Furnished?	No		No		No	
Type Recommended	High Velocity		High Velocity		High Velocity	
Hi Vel. (No.-Size-Thk.)	High Velocity		High Velocity		High Velocity	
Vent Pipe Diameter - Min. (in.) (e) (f)	1-16X25-1in.		1-20X25-1in.		1-24X25-1in.	
	2 Round		2 Round		3 Round	
Heat Exchanger Type						
Fired	409 Stainless Steel		409 Stainless Steel		409 Stainless Steel	
Unfired	29-4C Stainless Steel		29-4C Stainless Steel		29-4C Stainless Steel	
Gauge (Fired)	20		20		20	
Orifices - Main						
Nat. Gas Qty. - Drill Size	4-45		5-45		6-45	
Propane Gas Qty. - Drill Size	4-56		5-56		6-56	
Gas Valve	Redundant - One Stage		Redundant - One Stage		Redundant - One Stage	
Pilot Safety Device						
Type	120 V SiNi Igniter		120 V SiNi Igniter		120 V SiNi Igniter	
Burners - Type	Multiport Inshot		Multiport Inshot		Multiport Inshot	
Number	4		5		6	
Power Conn. - V/Ph/Hz	4		5		6	
Ampacity (Amps) (g)	120/1/60		120/1/60		120/1/60	
Max. Overcurrent Protection (Amps)	13.9		14.1		14.1	
Pipe Conn. Size (in.)	15		15		15	
	1/2		1/2		1/2	

(a) For U.S. applications, above input ratings (BTUH) are up to 2,000 feet, derate 4% per 1,000 feet for elevations above 2,000 feet above sea level. For Canadian applications, above input ratings (BTUH) are up to 4,500 feet, derate 4% per 1,000 feet for elevations above 4,500 feet above sea level.

(b) Central Furnace heating designs are certified to ANSI Z21.47 / CSA 2.3 — latest edition.

(c) Based on U.S. government standard tests.

(d) 9 Speed constant torque ECM blower motor.

(e) See the [Maximum Vent Length Table](#), p. 48 in this document.

(f) All furnace models have a vent outlet diameter that equals 2 in.

(g) The above wiring specifications are in accordance with National Electrical Code; however, installations must comply with local codes.

Table 7. Models S9X2B040U3PSBB, S9X2B060U4PSBB, S9X2B080U4PSBB, and S9X2C080U5PSBB

Model Number	S9X2B040U3PSBB	S9X2B060U4PSBB	S9X2B080U4PSBB	S9X2C080U5PSBB
Type	Upflow / Horizontal	Upflow / Horizontal	Upflow / Horizontal	Upflow / Horizontal
Ratings (a)				

Table 7. Models S9X2B040U3PSBB, S9X2B060U4PSBB, S9X2B080U4PSBB, and S9X2C080U5PSBB (continued)

Model Number	S9X2B040U3PSBB	S9X2B060U4PSBB	S9X2B080U4PSBB	S9X2C080U5PSBB
1st Stage Input BTUH	26,000	39,000	52,000	52,000
1st Stage Capacity BTUH (ICS)	25,220	37,830	50,440	50,440
2nd Stage Input BTUH	40,000	60,000	80,000	80,000
2nd Stage Capacity BTUH (ICS) ^(b) (c)	38,800	58,200	77,600	77,600
1st Stage Temp. Rise (Min. - Max.) °F	25 - 55	25 - 55	30 - 60	30 - 60
2nd Stage Temp. Rise (Min. - Max.) °F	30 - 60	30 - 60	45 - 75	40-70
AFUE (%) (c)	96.0	96.0	96.0	95.0
Return Air Temp. (Min.-Max.)	45°F - 80°F	45°F - 80°F	45°F - 80°F	45°F - 80°F
CEE Tier	2	2	2	2
Energy Star Rating Before July 31, 2026	US - All / Canada	US - All / Canada	US - All / Canada	US - All / Canada
Energy Star Rating On or After July 31, 2026	US - South	US - South	US - South	US - South
Energy Star Orientation	US - South	US - South	US - South	US - South
Integrated Furnace Control	Upflow / Horizontal	Upflow / Horizontal	Upflow / Horizontal	Upflow / Horizontal
Input-Communication Protocol	24 Volts	24 Volts	24 Volts	24 Volts
Blower Drive	DIRECT	DIRECT	DIRECT	DIRECT
Diameter - Width (in.)	11X8	11X8	11X8	11 X 10
No. Used	1	1	1	1
Speeds (No.) (d)	9	9	9	9
CFM vs. iwc	See Fan Performance Table 1/2	See Fan Performance Table 3/4	See Fan Performance Table 3/4	See Fan Performance Table 1
Motor HP	1075	1075	1075	1075
R.P.M.	120/1/60	120/1/60	120/1/60	120/1/60
Volts / Ph / Hz	6.4	8.4	8.4	10.6
FLA	Centrifugal	Centrifugal	Centrifugal	Centrifugal
Combustion Fan - Type	Centrifugal	Centrifugal	Centrifugal	Centrifugal
Drive - No. Speeds	Direct - 2	Direct - 2	Direct - 2	Direct - 2
Motor HP - RPM	3300/2600	3300/2600	3300/2600	3300/2600
Volts/Ph/Hz	120/1/60	120/1/60	120/1/60	120/1/60
FLA	0.66	0.66	0.66	0.66
Filter - Furnished?	No	No	No	No
Type Recommended	High Velocity	High Velocity	High Velocity	High Velocity
Hi Vel. (No.-Size-Thk.)	High Velocity	High Velocity	High Velocity	High Velocity
Vent Pipe Diameter - Min. (in.) (f)	1-16X25-1in.	1-16X25-1in.	1-16X25-1in.	1-20X25-1in.
(e)	2 Round	2 Round	2 Round	2 Round
Heat Exchanger Type				
Fired	409 Stainless Steel	409 Stainless Steel	409 Stainless Steel	409 Stainless Steel
Unfired	29-4C Stainless Steel	29-4C Stainless Steel	29-4C Stainless Steel	29-4C Stainless Steel

Product Specifications

Table 7. Models S9X2B040U3PSBB, S9X2B060U4PSBB, S9X2B080U4PSBB, and S9X2C080U5PSBB (continued)

Model Number	S9X2B040U3PSBB	S9X2B060U4PSBB	S9X2B080U4PSBB	S9X2C080U5PSBB
Gauge (Fired)	20	20	20	20
Orifices - Main				
Nat. Gas Qty. - Drill Size				
L.P. Gas Qty. - Drill Size	2-45	3-45	4-45	4-45
	2-56	3-56	4-56	4-56
Gas Valve	Redundant - Two Stage	Redundant - Two Stage	Redundant - Two Stage	Redundant - Two Stage
Pilot Safety Device				
Type	120 V SiNi Igniter	120 V SiNi Igniter	120 V SiNi Igniter	120 V SiNi Igniter
Burners - Type				
Number	Multiport Inshot	Multiport Inshot	Multiport Inshot	Multiport Inshot
Power Conn. - V/Ph/HZ	2	3	4	4
Ampacity (Amps) ^(g)	120/1/60	120/1/60	120/1/60	120/1/60
Max. Overcurrent Protection (Amps)	8.8	11.3	11.3	14.1
Pipe Conn. Size (in.)				
	15	15	15	15
	1/2	1/2	1/2	1/2

(a) For U.S. applications, above input ratings (BTUH) are up to 2,000 feet, derate 4% per 1,000 feet for elevations above 2,000 feet above sea level. For Canadian applications, above input ratings (BTUH) are up to 4,500 feet, derate 4% per 1,000 feet for elevations above 4,500 feet above sea level.

(b) Central Furnace heating designs are certified to ANSI Z21.47 / CSA 2.3 — latest edition.

(c) Based on U.S. government standard tests.

(d) 9 Speed constant torque ECM blower motor.

(e) See the [Maximum Vent Length Table, p. 48](#) in this document.

(f) All furnace models have a vent outlet diameter that equals 2 in.

(g) The above wiring specifications are in accordance with National Electrical Code; however, installations must comply with local codes.

Table 8. Models S9X2C100U5PSBB, S9X2D120U5PSBB, S9X2B040D3PSBB, and S9X2B060D3PSBB

Model Number	S9X2C100U5PSBB	S9X2D120U5PSBB	S9X2B040D3PSBB	S9X2B060D3PSBB
Type	Upflow / Horizontal	Upflow / Horizontal	Downflow	Downflow
Ratings ^(a)				
1st Stage Input BTUH	65,000	78,000	26,000	39,000
1st Stage Capacity BTUH (ICS)	63,050	75,660	25,220	37,830
2nd Stage Input BTUH	100,000	120,000	40,000	60,000
2nd Stage Capacity BTUH (ICS) ^(b) ^(c)	97,000	116,400	38,800	58,200
1st Stage Temp. Rise (Min. - Max.) °F	25 - 55	30 - 60	25 - 55	25 - 55
2nd Stage Temp. Rise (Min. - Max.) °F	40 - 70	40 - 70	30 - 60	35 - 65
AFUE (%) ^(c)	96.0	96.0	96.0	95.0
Return Air Temp. (Min.-Max.)	45°F - 80°F	45°F - 80°F	45°F - 80°F	45°F - 80°F
CEE Tier	2	2	2	2
Energy Star Rating Before July 31, 2026	US - All / Canada	US - All / Canada	US - All / Canada	US - All / Canada
Energy Star Rating On or After July 31, 2026	US - South	US - South	US - South	US - South
Integrated Furnace Control	Upflow / Horizontal	Upflow / Horizontal	Downflow	Downflow

Table 8. Models S9X2C100U5PSBB, S9X2D120U5PSBB, S9X2B040D3PSBB, and S9X2B060D3PSBB (continued)

Model Number	S9X2C100U5PSBB	S9X2D120U5PSBB	S9X2B040D3PSBB	S9X2B060D3PSBB
Input-Communication Protocol	24 Volts	24 Volts	24 Volts	24 Volts
Blower Drive	DIRECT	DIRECT	DIRECT	DIRECT
Diameter - Width (in.)	11 X 10	11 X 10	11X8	11X8
No. Used	1	1	1	1
Speeds (No.) (d)	9	9	9	9
CFM vs. iwc	See Fan Performance Table	See Fan Performance Table	See Fan Performance Table	See Fan Performance Table
Motor HP	1	1	1/2	1/2
R.P.M.	1075	1075	1075	1075
Volts / Ph / Hz	120/1/60	120/1/60	120/1/60	120/1/60
FLA	10.6	10.6	6.4	6.4
Combustion Fan - Type	Centrifugal	Centrifugal	Centrifugal	Centrifugal
Drive - No. Speeds	Direct - 2	Direct - 2	Direct - 2	Direct - 2
Motor HP - RPM	3300/2600	3300/2600	3300/2600	3300/2600
Volts/Ph/Hz	120/1/60	120/1/60	120/1/60	120/1/60
FLA	0.66	0.66	0.66	0.66
Filter - Furnished?	No	No	No	No
Type Recommended	High Velocity	High Velocity	High Velocity	High Velocity
Hi Vel. (No.-Size-Thk.)	High Velocity	High Velocity	High Velocity	High Velocity
Vent Pipe Diameter - Min. (in.) (f)	1-20X25-1in.	1-24X25-1in.	2-14x20-1in.	2-14x20-1in.
(e)	2 Round	3 Round	2 Round	2 Round
Heat Exchanger Type				
Fired	409 Stainless Steel	409 Stainless Steel	409 Stainless Steel	409 Stainless Steel
Unfired	29-4C Stainless Steel	29-4C Stainless Steel	29-4C Stainless Steel	29-4C Stainless Steel
Gauge (Fired)	20	20	20	20
Orifices - Main				
Nat. Gas Qty. - Drill Size	5-45	6-45	2-45	3-45
L.P. Gas Qty. - Drill Size	5-56	6-56	2-56	3-56
Gas Valve	Redundant - Two Stage	Redundant - Two Stage	Redundant - Two Stage	Redundant - Two Stage
Pilot Safety Device				
Type	120 V SiNi Igniter	120 V SiNi Igniter	120 V SiNi Igniter	120 V SiNi Igniter
Burners - Type				
Number	Multiport Inshot	Multiport Inshot	Multiport Inshot	Multiport Inshot
Power Conn. - V/Ph/HZ	5	6	2	3
Ampacity (Amps) (g)	120/1/60	120/1/60	120/1/60	120/1/60
Max. Overcurrent Protection (Amps)	14.1	14.1	8.8	8.8
Pipe Conn. Size (in.)				
	15	15	15	15
	1/2	1/2	1/2	1/2

(a) For U.S. applications, above input ratings (BTUH) are up to 2,000 feet, derate 4% per 1,000 feet for elevations above 2,000 feet above sea level. For Canadian applications, above input ratings (BTUH) are up to 4,500 feet, derate 4% per 1,000 feet for elevations above 4,500 feet above sea level.
 (b) Central Furnace heating designs are certified to ANSI Z21.47 / CSA 2.3 — latest edition.
 (c) Based on U.S. government standard tests.
 (d) 9 Speed constant torque ECM blower motor.

Product Specifications

Table 8. Models S9X2C100U5PSBB, S9X2D120U5PSBB, S9X2B040D3PSBB, and S9X2B060D3PSBB (continued)

- (e) See the [Maximum Vent Length Table](#), p. 48 in this document.
 (f) All furnace models have a vent outlet diameter that equals 2 in.
 (g) The above wiring specifications are in accordance with National Electrical Code; however, installations must comply with local codes.

Table 9. Models S9X2B080D4PSBB, S9X2C100D5PSBB, and S9X2D120D5PSBB

Model Number	S9X2B080D4PSBB	S9X2C100D5PSBB	S9X2D120D5PSBB
Type	Downflow	Downflow	Downflow
Ratings (a)			
1st Stage Input BTUH 1st Stage Capacity	52,000	65,000	78,000
BTUH (ICS) 2nd Stage Input BTUH 2nd	50,440	63,050	75,660
Stage Capacity BTUH (ICS) (b) (c) 1st Stage	80,000	100,000	120,000
Temp. Rise (Min. - Max.) °F 2nd Stage	77,600	97,000	116,400
Temp. Rise (Min. - Max.) °F AFUE (%) (c)	30 - 60	25-55	30 - 60
Return Air Temp. (Min.-Max.) CEE Tier	45-75	40-70	45-75
Energy Star Rating Before July 31, 2026	96.0	95.0	96.0
Energy Star Rating On or After July 31, 2026	45°F - 80°F	45°F - 80°F	45°F - 80°F
Energy Star Orientation	2	2	2
Integrated Furnace Control	US - All / Canada	US - All / Canada	US - All / Canada
	US - South	US - South	US - South
	Downflow	Downflow	Downflow
Input-Communication Protocol	24 Volts	24 Volts	24 Volts
Blower Drive	DIRECT	DIRECT	DIRECT
Diameter - Width (in.)	11X8	11 X 10	11 X 10
No. Used	1	1	1
Speeds (No.) (d)	9	9	9
CFM vs. iwc	See Fan Performance Table	See Fan Performance Table	See Fan Performance Table
Motor HP	3/4	1	1
R.P.M.	1075	1075	1075
Volts / Ph / Hz	120/1/60	120/1/60	120/1/60
FLA	9.3	10.6	10.6
Combustion Fan - Type	Centrifugal	Centrifugal	Centrifugal
Drive - No. Speeds	Direct - 2	Direct - 2	Direct - 2
Motor HP - RPM	3300/2600	3300/2600	3300/2600
Volts/Ph/Hz	120/1/60	120/1/60	120/1/60
FLA	0.66	0.66	0.66
Filter - Furnished?	No	No	No
Type Recommended	High Velocity	High Velocity	High Velocity
Hi Vel. (No.-Size-Thk.)	2-14x20-1in.	2-16x20-1in.	2-16x20-1in.
Vent Pipe Diameter - Min. (in.) (e) (f)	2 Round	2 Round	3 Round
Heat Exchanger Type			

Table 9. Models S9X2B080D4PSBB, S9X2C100D5PSBB, and S9X2D120D5PSBB (continued)

Model Number	S9X2B080D4PSBB	S9X2C100D5PSBB	S9X2D120D5PSBB
Fired	409 Stainless Steel	409 Stainless Steel	409 Stainless Steel
Unfired	29-4C Stainless Steel	29-4C Stainless Steel	29-4C Stainless Steel
Gauge (Fired)	20	20	20
Orifices - Main			
Nat. Gas Qty. - Drill Size	4-45	5-45	6-45
L.P. Gas Qty. - Drill Size	4-56	5-56	6-56
Gas Valve	Redundant - Two Stage	Redundant - Two Stage	Redundant - Two Stage
Pilot Safety Device			
Type	120 V SiNi Igniter	120 V SiNi Igniter	120 V SiNi Igniter
Burners - Type			
Number	Multiport Inshot	Multiport Inshot	Multiport Inshot
Power Conn. - V/Ph/HZ	4	5	6
Ampacity (Amps) ^(g)	120/1/60	120/1/60	120/1/60
Max. Overcurrent Protection (Amps)	12.4	14.1	14.1
Pipe Conn. Size (in.)	15	15	15
	1/2	1/2	1/2

- (a) For U.S. applications, above input ratings (BTUH) are up to 2,000 feet, derate 4% per 1,000 feet for elevations above 2,000 feet above sea level. For Canadian applications, above input ratings (BTUH) are up to 4,500 feet, derate 4% per 1,000 feet for elevations above 4,500 feet above sea level.
- (b) Central Furnace heating designs are certified to ANSI Z21.47 / CSA 2.3 — latest edition.
- (c) Based on U.S. government standard tests.
- (d) 9 Speed constant torque ECM blower motor.
- (e) See the [Maximum Vent Length Table, p. 48](#) in this document.
- (f) All furnace models have a vent outlet diameter that equals 2 in.
- (g) The above wiring specifications are in accordance with National Electrical Code; however, installations must comply with local codes.

Furnace Installation Guidelines

The following sections give general guidelines for the installation of the gas furnaces.

Safety Practices and Precautions

The following safety practices and precautions must be followed during the installation, servicing, and operation of this Furnace.

1. Use only with the type gas approved for this Furnace. Refer to the Furnace rating plate.
2. Install the Furnace only in a location and position as specified in “Locations and Clearances,” p. 23 of these instructions.
3. Provide adequate combustion and ventilation air to the Furnace space as specified in “Air for Combustion and Ventilation,” p. 56 of these instructions.
4. Combustion products must be discharged outdoors. Connect this Furnace to an approved vent system only, as specified in the “Horizontal Venting,” p. 49 section of these instructions.
5. Never test for gas leaks with an open flame. Use a commercially available soap solution made specifically for the detection of leaks to check all connections, as specified in the “Gas Piping,” p. 37 section of these instructions.
6. Always install the Furnace to operate within the Furnace’s intended temperature-rise range with a duct system which has an external static pressure within the allowable range, as specified on the unit rating plate. Airflow within temperature rise for cfm versus static is shown in the CFM Versus Temperature Rise section in this document accompanying this Furnace.
7. When a Furnace is installed so that the supply ducts carry air circulated by the Furnace to areas outside the space containing the Furnace, the return air shall also be handled by a duct(s) sealed to the Furnace casing and terminating outside the space containing the Furnace.
8. A gas-fired Furnace for installation in a residential garage must be installed as specified in “Locations and Clearances,” p. 23 section of these instructions.
9. The furnace may be used for temporary heating of buildings or structures under construction only when the following conditions have been met:
 - a. The Furnace venting system must be complete and installed per manufacturer’s instructions.
 - b. The Furnace is controlled only by a room Comfort Control (no field jumpers).
 - c. The Furnace return air duct must be complete and sealed to the Furnace.
 - d. The Furnace input rate and temperature rise must be verified to be within the nameplate marking.

- e. A minimum 4-inch MERV 11 air filter must be in place.
- f. 100% of the Furnace combustion air requirement must come from outside the structure.
- g. The Furnace return air temperature range is between 55 and 80 Fahrenheit.
80% models = 55°F
90%+ models = 45°F.
- h. Clean the Furnace, ductwork, and components upon substantial completion of the construction process, and verify Furnace operating conditions including ignition, input rate, temperature rise, and venting, according to the manufacturer’s instructions.

10. In the Commonwealth of Massachusetts, this product must be gas piped by a Licensed Plumber or Gas Fitter.

This Furnace is certified to leak 1% or less of nominal air conditioning CFM delivered when pressurized to 0.5-inch water column with all inlets, outlets, and drains sealed.

General Guidelines

The manufacturer assumes no responsibility for equipment installed in violation of any code or regulation.

It is recommended that Manual J of the Air Conditioning Contractors Association (ACCA) or A.R.I. 230 be followed in estimating heating requirements. When estimating heating requirements for installation at Altitudes above 2000 ft., remember the gas input must be reduced. See Combustion and Input Check.

Material in this shipment has been inspected at the factory and released to the transportation agency without known damage. Inspect exterior of carton for evidence of rough handling in shipment. Unpack carefully after moving equipment to approximate location. If damage to contents is found, report the damage immediately to the delivering agency.

Codes and local utility requirements governing the installation of gas fired equipment, wiring, plumbing, and flue connections must be adhered to. In the absence of local codes, the installation must conform with latest edition of the National Fuel Gas Code ANSI Z223.1 / NFPA 54 • National Installation Code, CAN/CGA B149.1. The latest code may be obtained from the American Gas Association, 400 N. Capitol St. NW, Suite 450 Washington, D.C. 20001, 1-855-999-9870 or www.aga.org.

These furnaces have been classified as CATEGORY IV furnaces in accordance with latest edition of ANSI Z21.47 standards • CSA 2.3. Category IV furnaces operate with positive vent static pressure and with a flue loss less than 17 percent. These conditions require special venting systems, which must be gas tight and water tight. These Category IV Direct Vent furnaces are approved for

installation in Manufactured/ Mobile housing when used with BAYMFGH200B.

A manufactured (mobile) home installation must conform with the *Manufactured Home Construction and Safety Standard, Title 24 CFR, Part 3280*, or when this standard is not applicable, the *Standard for Model Manufactured Home Installation, NFPA 225*, or the *Canadian Standard for Manufactured Homes, CSA Z240 MH*.

Locations and Clearances

The location of the furnace is normally selected by the architect, the builder, or the installer. However, before the furnace is moved into place, be sure to consider the following requirements:

1. Is the location selected as near the chimney or vent and as centralized for heat distribution as practical?
2. Do all clearances between the furnace and enclosure equal or exceed the minimums stated in the table below?

Table 10. Location and clearances

Minimum clearance to combustible materials (in.)	
Closet	
Sides	0
Back	1
Top	1
Front	0
Bottom	0
Flue	0
24 in. minimum front clearance recommended for service	
Horizontal Closet and Alcove	
Right Side	0
Left Side	0
Back	1
Top	1
Bottom	0
Flue	0
Horizontal Flue (discharge on left)	
Closet	
Right Side	0
Left Side	0
Rear	1
Top	1
Bottom	0
Flue	0

3. Is there sufficient space for servicing the furnace and other equipment? A minimum of 24 inches front accessibility to the furnace must be provided. Any access door or panel must permit removal of the largest component.
4. Are there at least 3 inches of clearance between the furnace combustion air openings in the front panel and any closed panel or door provided?
5. Are the ventilation and combustion air openings large enough and will they remain unobstructed? If outside air is used, are the openings set 12-inch above the highest snow accumulation level?
6. Allow sufficient height in supply plenum above the furnace to provide for cooling coil installation, if the cooling coil is not installed at the time of this furnace installation.
7. The furnaces shall be installed so electrical components are protected from water.
8. A vertical downflow furnace without a coil, must use BAYBASE205 when installed on combustible flooring.
9. If the furnace is installed in a garage, it must be installed so that the burners, and the ignition source are located not less than 18 inches above the floor and the furnace must be located or protected to avoid physical damage from vehicles.
10. The gas furnace must not be located where excessive exposure to contaminated combustion air will result in safety and performance related problems. Avoid the following contaminants:
 - Permanent wave solutions
 - Chlorinated waxes and cleaners
 - Chlorine based swimming pool chemicals
 - Water softening chemicals
 - De-icing salts or chemicals
 - Carbon tetrachloride
 - Halogen type refrigerants
 - Cleaning solvents (such as perchloroethylene)
 - Printing inks, paint removers, varnishes, etc.
 - Hydrochloric acid, Cements and glues
 - Antistatic fabric softeners for clothes dryers
 - Masonry acid washing materials

Important: *The furnace must be installed level. The only allowable variation would be slightly to the left and/ or forward in upflow or downflow installations or slightly toward the front in horizontal installations. This is necessary for proper condensate drainage.*

Dimensional Data

Figure 1. Upflow cabinets — 17.5-inch, 21-inch, and 24.5-inch

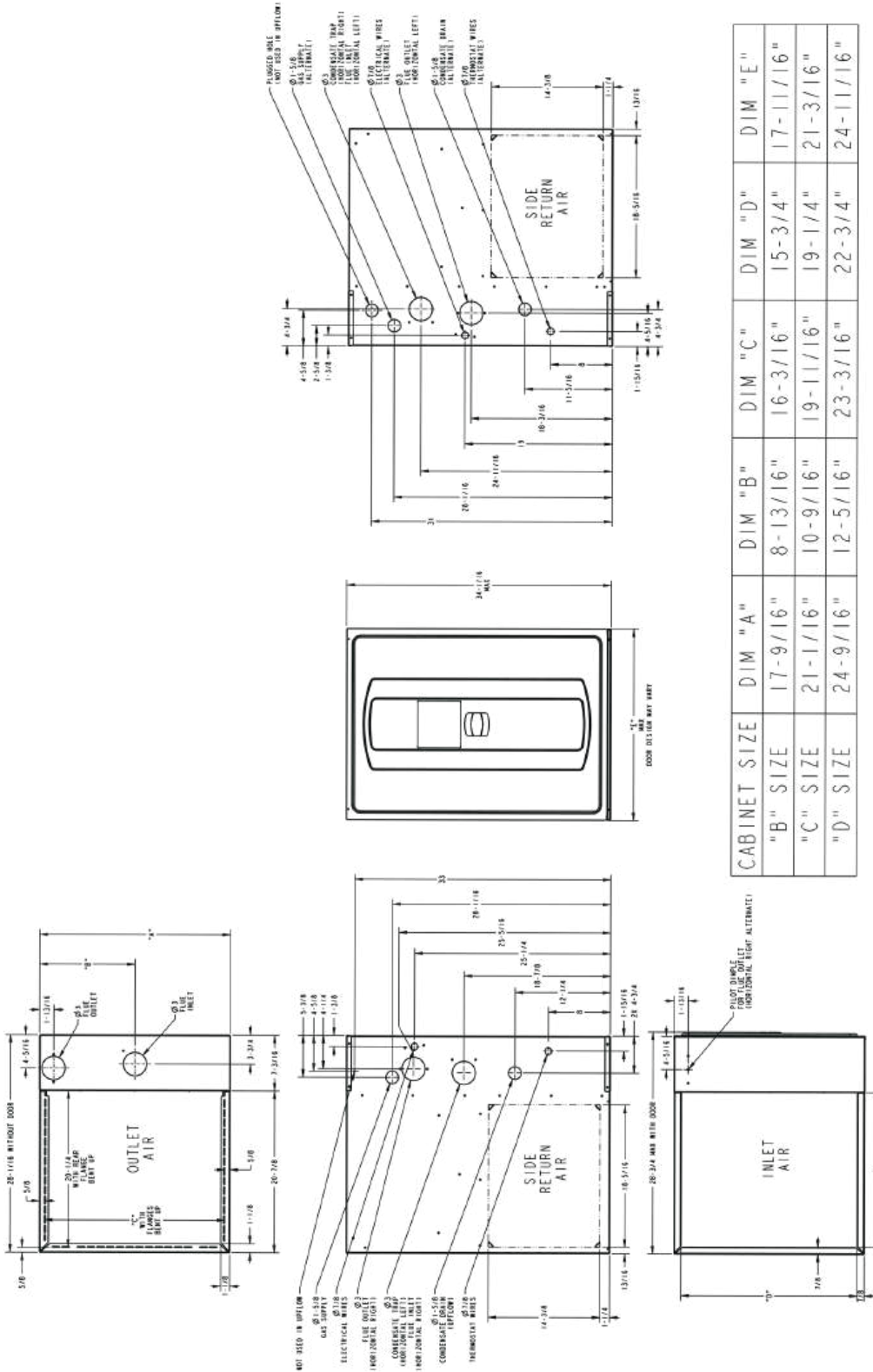
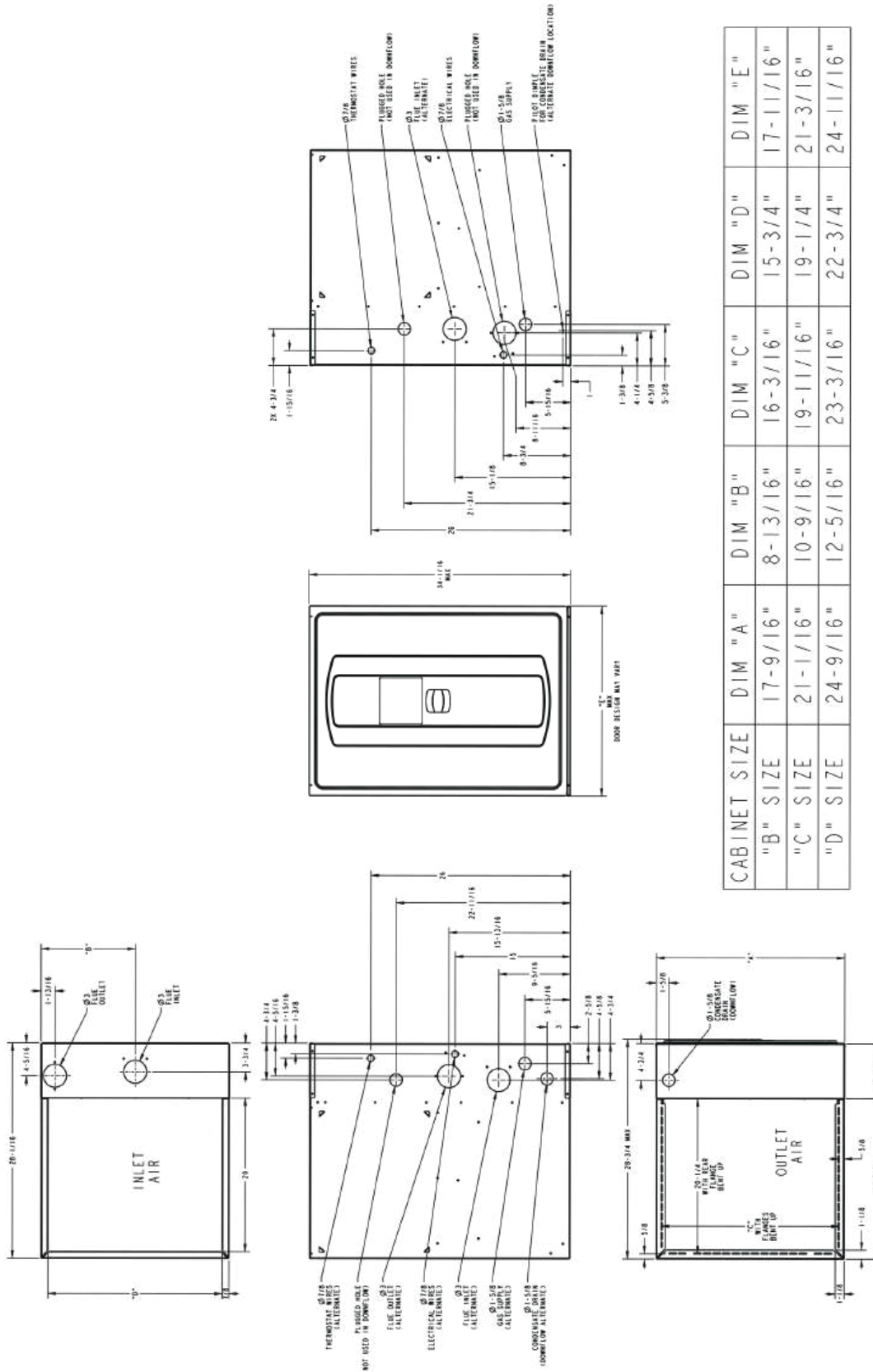

Figure 2. Downflow cabinets — 17.5-inch, 21-inch, and 24.5-inch



CABINET SIZE	DIM "A"	DIM "B"	DIM "C"	DIM "D"	DIM "E"
"B" SIZE	17-9/16"	8-13/16"	16-3/16"	15-3/4"	17-11/16"
"C" SIZE	21-1/16"	10-9/16"	19-11/16"	19-1/4"	21-3/16"
"D" SIZE	24-9/16"	12-5/16"	23-3/16"	22-3/4"	24-11/16"

Wiring Diagrams

Figure 3. Wiring diagram - S9X1

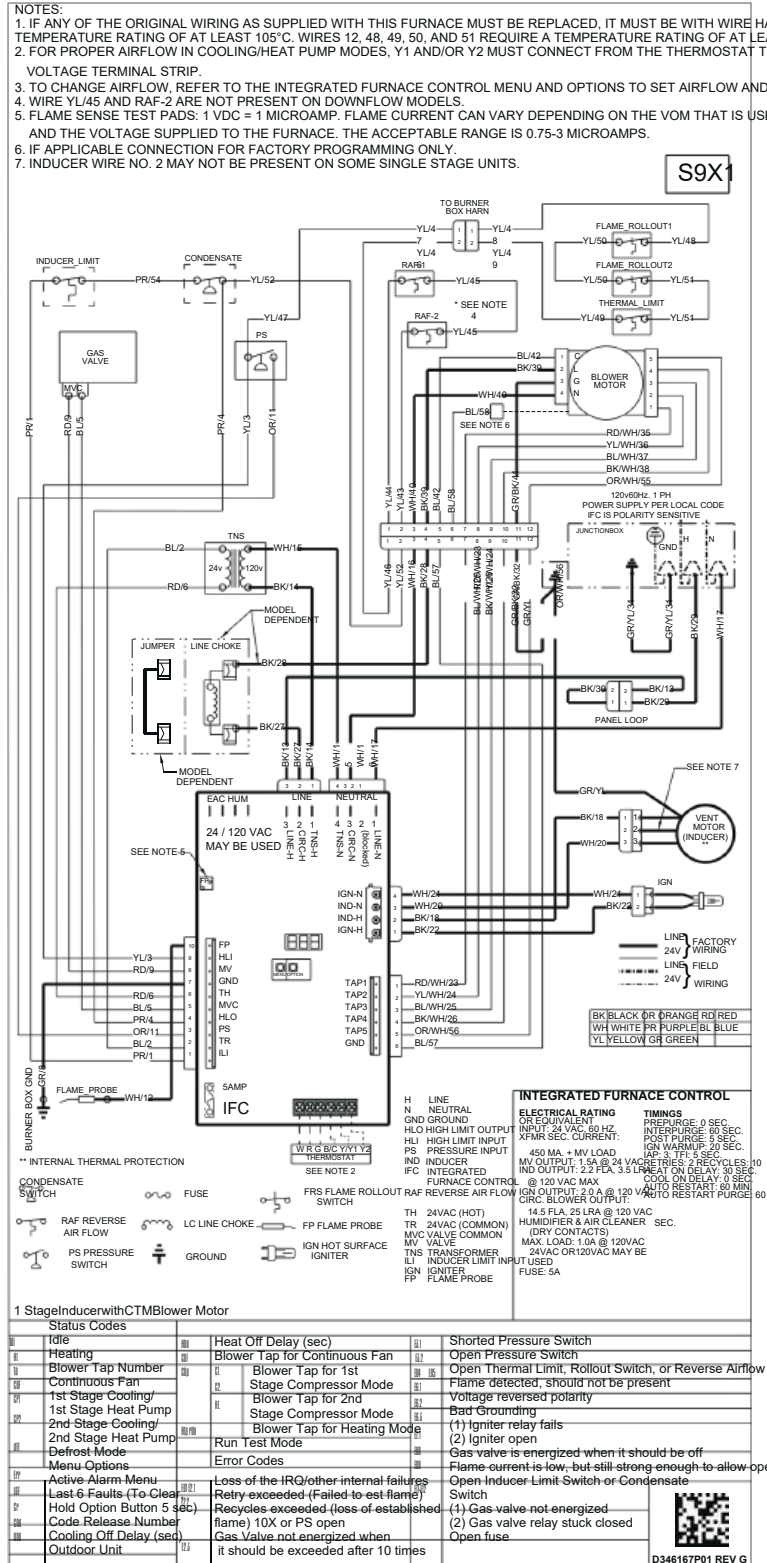
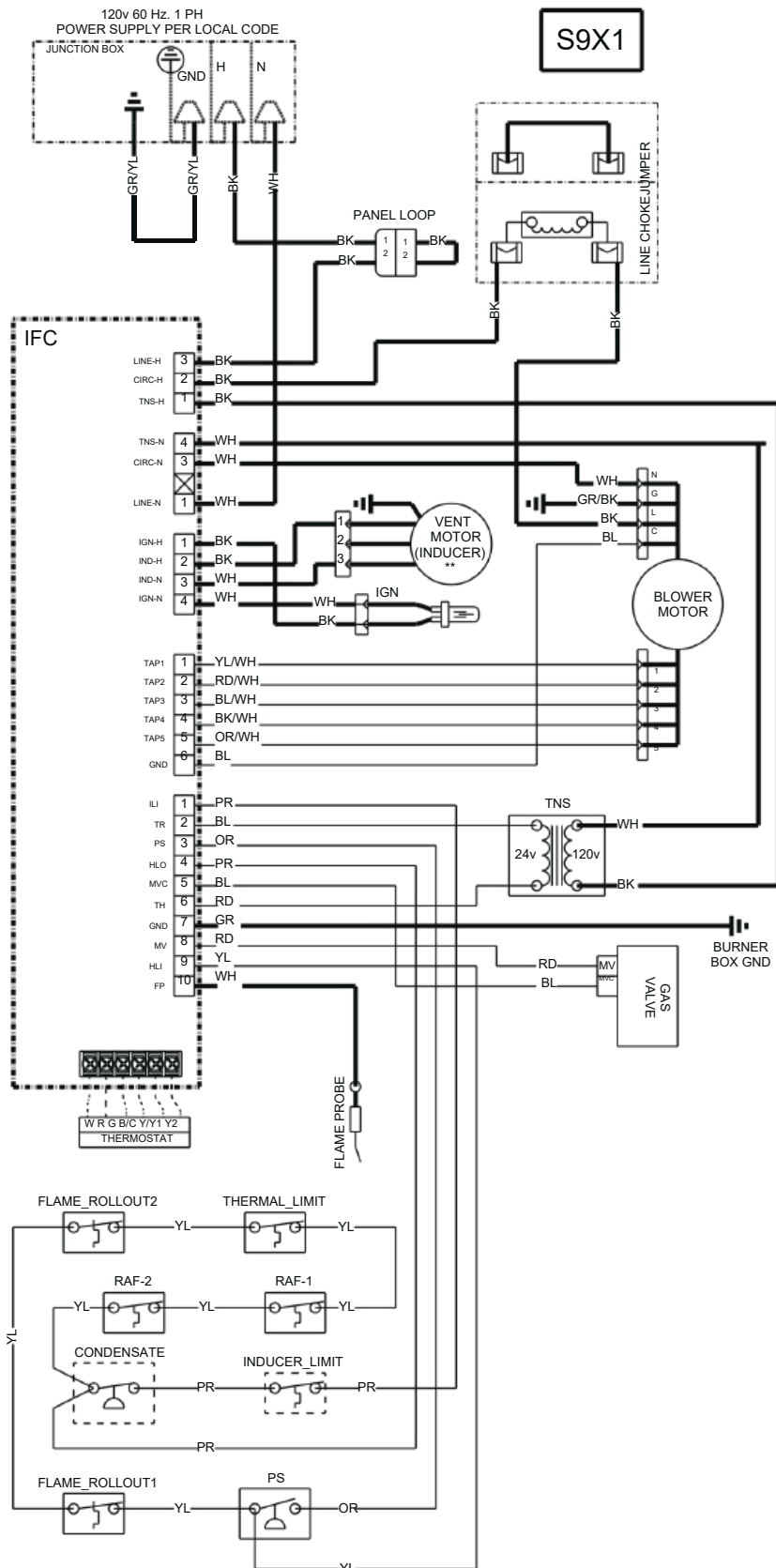

Figure 4. Ladder diagram - S9X1



Wiring Diagrams

Figure 5. Wiring diagram - S9B1

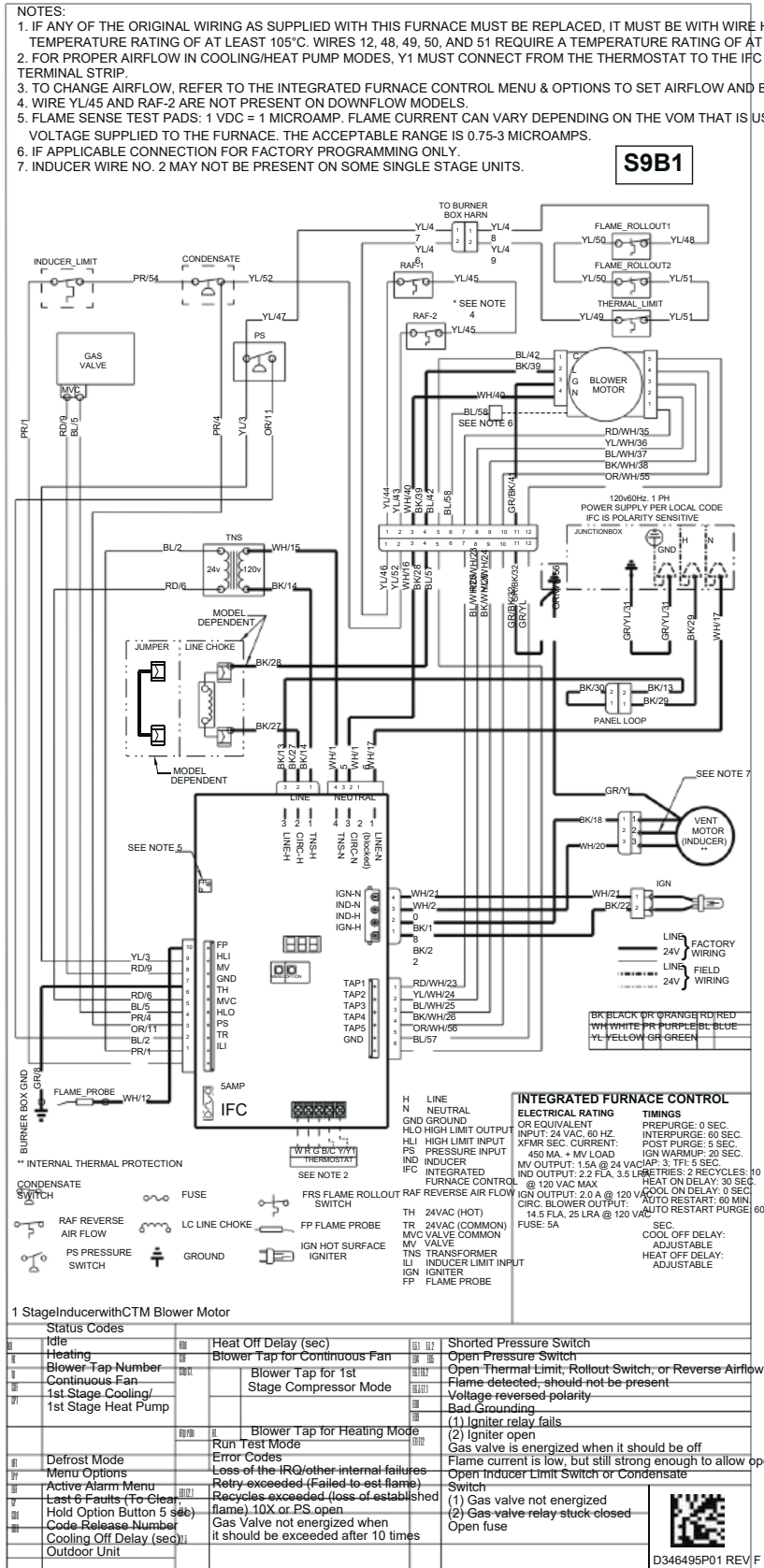
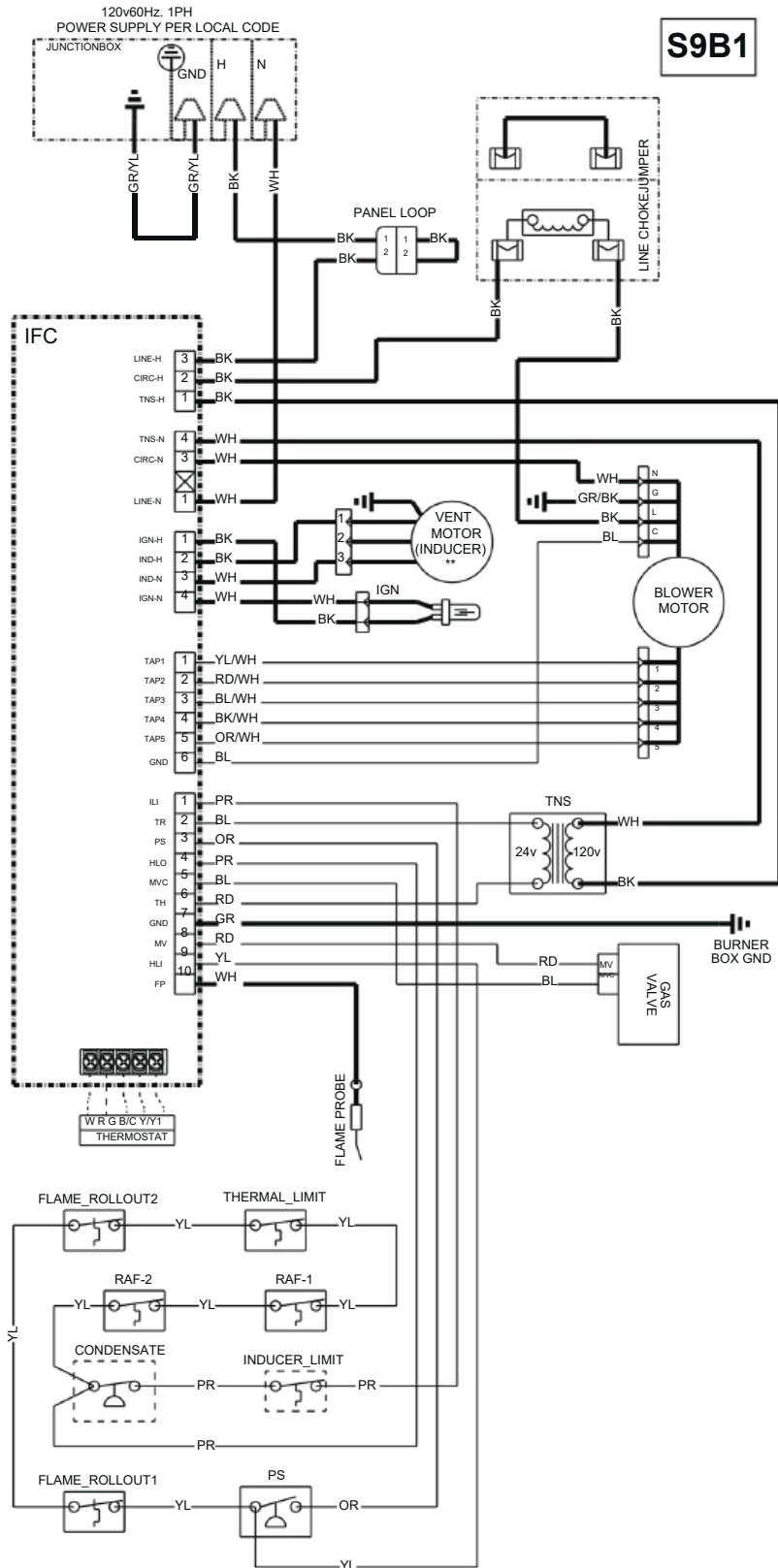

Figure 6. Ladder diagram - S9B1



Wiring Diagrams

Figure 7. Wiring diagram - S9X2

- NOTES:
- IF ANY OF THE ORIGINAL WIRING AS SUPPLIED WITH THIS FURNACE MUST BE REPLACED, IT MUST BE WITH WIRE HAVING A TEMPERATURE RATING OF AT LEAST 105°C. WIRES 12, 18, 48, 49, 50, AND 51 REQUIRE A TEMPERATURE RATING OF AT LEAST 250°C.
 - FOR PROPER AIRFLOW IN COOLING/HEAT PUMP MODES, Y1 AND/OR Y2 MUST CONNECT FROM THE THERMOSTAT TO THE IFC LOW VOLTAGE TERMINAL STRIP.
 - FOR COOLING ONLY SYSTEMS, LEAVE Y1-0 JUMPER IN PLACE ON THE IFC FOR CORRECT LED READOUT.
 - FOR HEAT PUMP SYSTEMS, REMOVE THE Y1-0 JUMPER, CONNECT "O" FROM THE THERMOSTAT TO "O" ON THE IFC LOW VOLTAGE TERMINAL STRIP FOR CORRECT LED READOUT AND DEFROST OPERATION.
 - IF USING A SINGLE STAGE HEATING THERMOSTAT, JUMPER W1 AND W2 TERMINALS AT THE LOW VOLTAGE TERMINAL STRIP. HT2 WILL BE SHOWN ON THE SEVEN SEGMENT DISPLAY AT ALL TIMES. SECOND STAGE OPERATION WILL BEGIN AFTER THE INTERSTAGE DELAY HAS COMPLETED.
 - TO CHANGE AIRFLOW, REFER TO THE INTEGRATED FURNACE CONTROL MENU AND OPTIONS TO SET AIRFLOW AND BLOWER DELAYS.
 - WIRE YL45 AND RAF-2 ARE NOT PRESENT ON DOWNFLOW MODELS.
 - FLAME SENSE TEST PADS: 1 VDC = 1 MICROAMP. FLAME CURRENT CAN VARY DEPENDING ON THE VOM THAT IS USED AND THE VOLTAGE SUPPLIED TO THE FURNACE. THE ACCEPTABLE RANGE IS 0.75-3 MICROAMPS.
 - IF APPLICABLE CONNECTION FOR FACTORY PROGRAMMING ONLY.

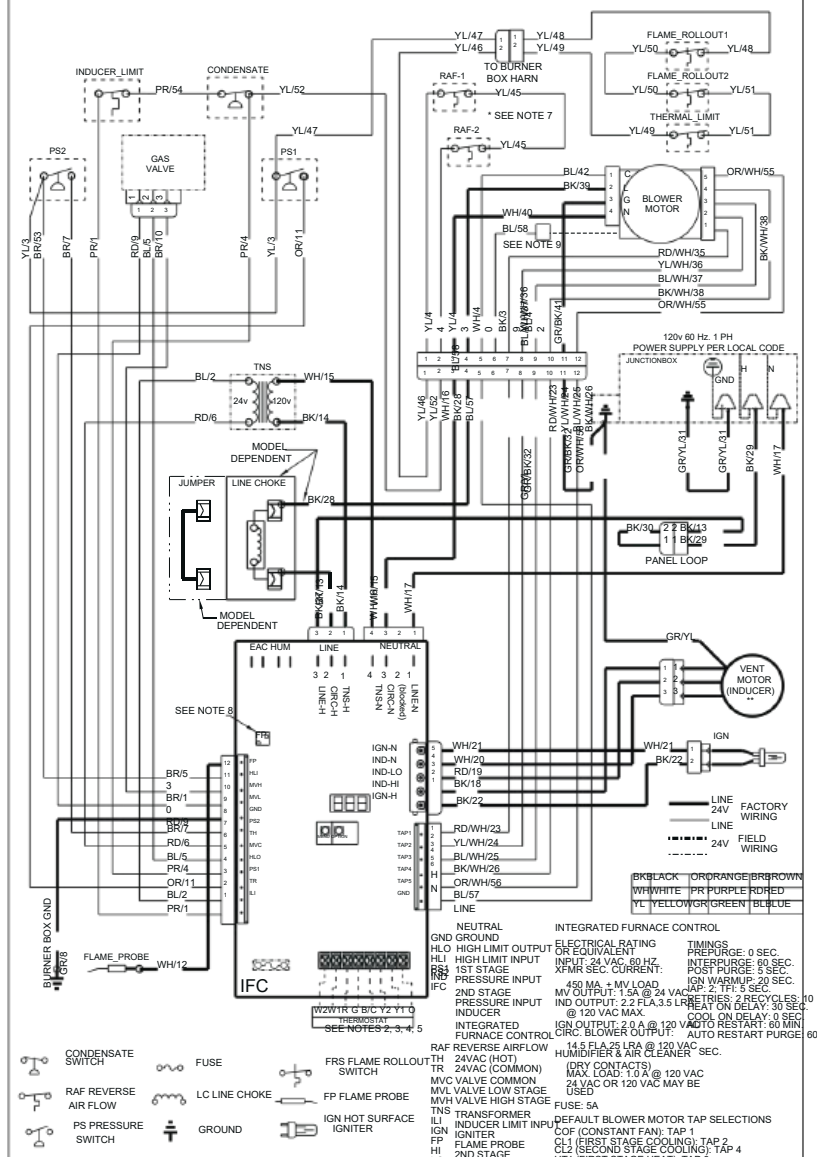

Status Codes	Inter-Stage Delay (sec)	Open Pressure Switch, 2nd Stage
Idle	Blower Tap Number for Continuous Fan	Open Thermal Limit, Rollout Switch, or Reverse Airflow Switch
1st Stage Heating	C1. Blower Tap for 1st Stage	Flame detected, should not be present
2nd Stage Heating	Compressor Mode	Voltage reversed polarity
Blower Tap Number	C2. Blower Tap for 2nd Stage	Bad Grounding
Continuous Fan	Compressor Mode	(1) Igniter relay fails
1st Stage Cooling	Blower Tap for 1st Stage Heating	(2) Igniter open
2nd Stage Cooling	Blower Tap for 2nd Stage Heating	1st stage gas valve (MVL) is energized when it should be off
1st Stage Heat Pump	Run Test Mode	Flame current is low, but still strong enough to allow operation.
2nd Stage Heat Pump	Error Codes	Open Inducer Limit Switch or Condensate Switch
Defrost Mode	Loss of the IRQ/other internal failures	(1) 1st stage gas valve not energized when it should be
Menu Options	Retry exceeded (Failed to est flame)	(2) 1st stage gas valve relay stuck closed
Active Alarm Menu	Recycles exceeded (loss of established flame) or 10X PS-1 open	(3) 2nd stage gas valve relay stuck closed
Last 6 Faults (To Clear Hold Option Button 5 sec)	1st Stage Gas Valve not energized when it should be exceeded after 10 times	(4) 2nd stage gas valve energized when it should not be
Code Release Number	Shorted Pressure Switch, 1st Stage	(5) 2nd stage gas valve not energized when it should be
Cooling Off Delay (sec)	Open Pressure Switch, 1st Stage	Open fuse
Outdoor Unit	Shorted Pressure Switch, 2nd Stage	
Heat Off Delay (sec)		

S9X2

D346024P01 REV F

Figure 8. Ladder diagram - S9X2

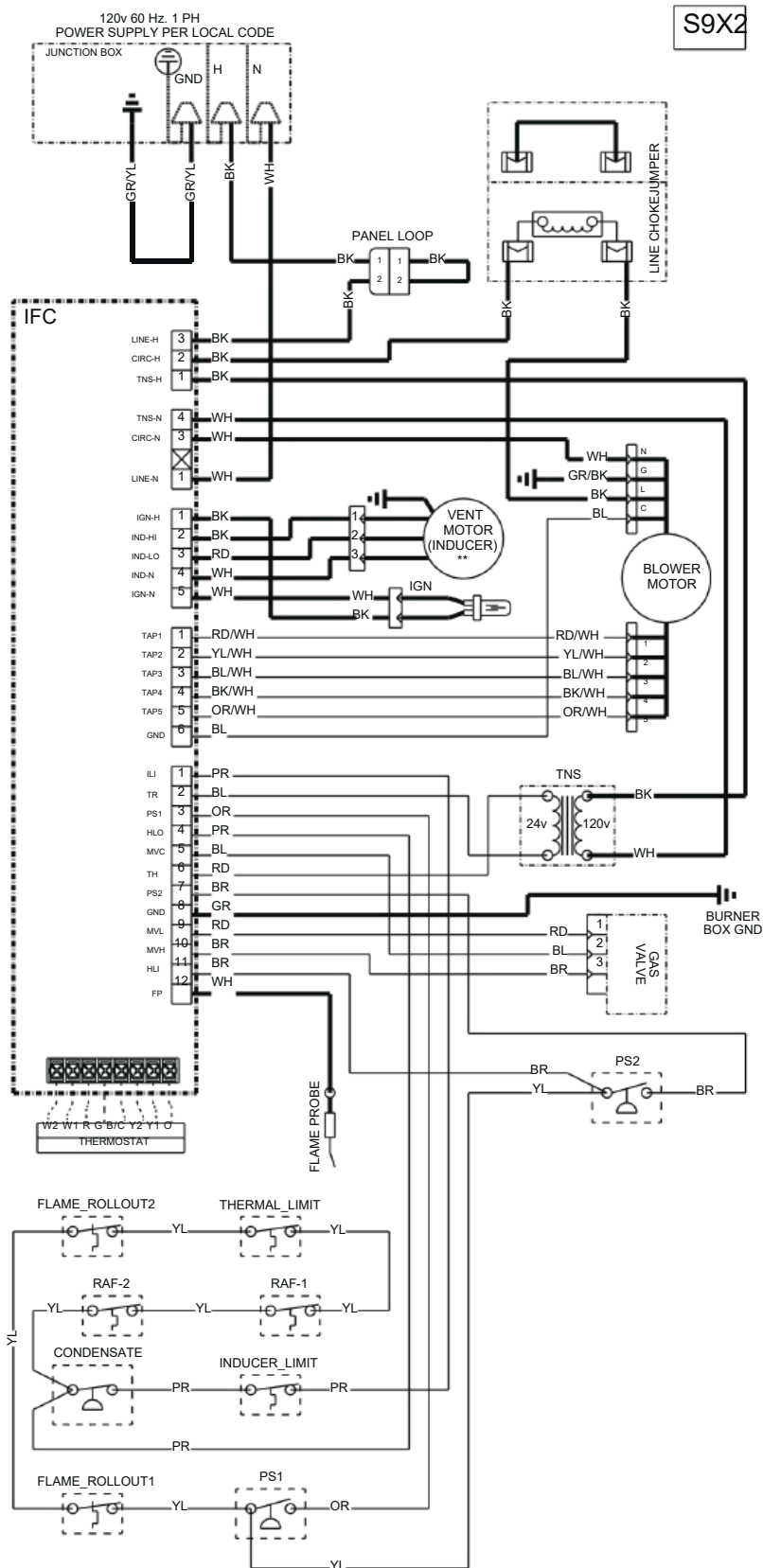

Airflow Tables

Table 11. Upflow — models S9X1B040U3PSBB, S9B1B040U3PSAB, and S9X2B040U3PSBB

Furnace Airflow (CFM) Vs. External Static Pressure (in. W.C.)							
Model	Tap		0.1	0.3	0.5	0.7	0.9
S9X1B040U3PSBB S9B1B040U3PSAB S9X2B040U3PSBB	1	SCFM / Watts	510 / 34	314 / 43	118 / 52	-	-
	2	SCFM / Watts	532 / 36	341 / 45	150 / 54	-	-
	3	SCFM / Watts	877 / 91	748 / 104	620 / 118	491 / 131	362 / 144
	4	SCFM / Watts	933 / 106	813 / 120	693 / 133	573 / 147	452 / 161
	5	SCFM / Watts	1056 / 140	950 / 156	843 / 172	737 / 188	631 / 204
	6	SCFM / Watts	1111 / 157	1009 / 174	908 / 190	806 / 207	705 / 223
	7	SCFM / Watts	1174 / 182	1078 / 199	983 / 216	887 / 233	791 / 251
	8	SCFM / Watts	1376 / 285	1297 / 305	1218 / 325	1140 / 344	1061 / 364
	9	SCFM / Watts	1512 / 382	1445 / 403	1378 / 424	1312 / 445	1245 / 466

Table 12. Upflow — models S9X1B060U4PSBB, S9B1B060U4PSAB, and S9X2B060U4PSBB

Furnace Airflow (CFM) Vs. External Static Pressure (in. W.C.)							
Model	Tap	0.5	0.1	0.3		0.7	0.9
S9X1B060U4PSBB S9B1B060U4PSAB S9X2B060U4PSBB	1	SCFM / Watts	840 / 91	702 / 101	565 / 111	427 / 121	290 / 130
	2	SCFM / Watts	1001 / 137	893 / 149	786 / 162	678 / 174	571 / 186
	3	SCFM / Watts	1140 / 193	1051 / 207	963 / 221	875 / 235	786 / 249
	4	SCFM / Watts	1208 / 223	1128 / 238	1048 / 253	969 / 268	889 / 283
	5	SCFM / Watts	1299 / 270	1224 / 284	1148 / 298	1073 / 312	998 / 327
	6	SCFM / Watts	1413 / 343	1348 / 359	1283 / 375	1217 / 391	1152 / 406
	7	SCFM / Watts	1444 / 354	1380 / 370	1315 / 386	1251 / 403	1186 / 419
	8	SCFM / Watts	1727 / 612	1674 / 631	1622 / 650	1570 / 668	1518 / 687
	9	SCFM / Watts	1790 / 694	1741 / 712	1691 / 729	1642 / 747	1593 / 765

Table 13. Upflow — models S9X1B080U4PSBB, S9B1B080U4PSAB, and S9X2B080U4PSBB

Furnace Airflow (CFM) Vs. External Static Pressure (in. W.C.)							
Model	Tap		0.1	0.3	0.5	0.7	0.9
S9X1B080U4PSBB S9B1B080U4PSAB S9X2B080U4PSBB	1	SCFM / Watts	911 / 94	766 / 104	622 / 115	477 / 125	332 / 136
	2	SCFM / Watts	1075 / 139	963 / 153	851 / 168	740 / 182	628 / 197
	3	SCFM / Watts	1215 / 185	1121 / 202	1028 / 219	934 / 236	840 / 253
	4	SCFM / Watts	1250 / 203	1164 / 221	1077 / 239	990 / 257	903 / 274
	5	SCFM / Watts	1349 / 251	1272 / 271	1194 / 291	1116 / 310	1039 / 330
	6	SCFM / Watts	1453 / 313	1387 / 335	1321 / 356	1254 / 378	1188 / 400
	7	SCFM / Watts	1505 / 340	1438 / 362	1372 / 384	1305 / 406	1239 / 427
	8	SCFM / Watts	1657 / 453	1597 / 477	1538 / 500	1479 / 524	1419 / 547
	9	SCFM / Watts	1878 / 669	1815 / 686	1752 / 702	1690 / 718	1627 / 735

Table 14. Upflow — models S9X1C080U5PSBB, S9B1C080U5PSAB, and S9X2C080U5PSBB

Furnace Airflow (CFM) Vs. External Static Pressure (in. W.C.)							
Model	Tap	0.5	0.1	0.3		0.7	0.9
S9X1C080U5PSBB S9B1C080U5PSAB S9X2C080U5PSBB	1	SCFM / Watts	643 / 45	384 / 53	125 / 62	-	-
	2	SCFM / Watts	1125 / 126	982 / 142	838 / 158	694 / 174	551 / 190
	3	SCFM / Watts	1192 / 140	1038 / 157	884 / 174	730 / 191	576 / 208
	4	SCFM / Watts	1509 / 245	1377 / 268	1246 / 291	1115 / 314	983 / 337
	5	SCFM / Watts	1548 / 257	1428 / 281	1308 / 304	1187 / 328	1067 / 352
	6	SCFM / Watts	1602 / 320	1467 / 345	1331 / 371	1196 / 396	1061 / 421
	7	SCFM / Watts	1640 / 352	1512 / 379	1383 / 406	1255 / 433	1127 / 459
	8	SCFM / Watts	1831 / 521	1778 / 550	1726 / 579	1673 / 608	1621 / 637
	9	SCFM / Watts	2351 / 886	2278 / 918	2204 / 950	2131 / 982	2058 / 1014

Table 15. Upflow — models S9X1C100U5PSBB, S9B1C100U5PSAB, and S9X2C100U5PSBB

Furnace Airflow (CFM) Vs. External Static Pressure (in. W.C.)							
Model	Tap	0.5	0.1	0.3		0.7	0.9
S9X1C100U5PSBB S9B1C100U5PSAB S9X2C100U5PSBB	1	SCFM / Watts	1013 / 104	847 / 116	680 / 129	514 / 142	348 / 155
	2	SCFM / Watts	1261 / 168	1126 / 185	990 / 202	854 / 219	718 / 236
	3	SCFM / Watts	1519 / 267	1407 / 290	1296 / 313	1184 / 336	1072 / 358
	4	SCFM / Watts	1554 / 283	1446 / 307	1337 / 330	1229 / 353	1120 / 377
	5	SCFM / Watts	1749 / 385	1651 / 411	1554 / 436	1457 / 462	1359 / 488
	6	SCFM / Watts	1868 / 464	1778 / 491	1688 / 519	1599 / 546	1509 / 574
	7	SCFM / Watts	2018 / 573	1936 / 602	1853 / 631	1770 / 660	1688 / 689
	8	SCFM / Watts	2191 / 718	2112 / 750	2033 / 782	1954 / 815	1875 / 847
	9	SCFM / Watts	2395 / 966	2303 / 981	2212 / 996	2120 / 1012	2028 / 1027

Table 16. Upflow — models S9X1D120U5PSBB, S9B1D120U5PSAB, and S9X2D120U5PSBB

Furnace Airflow (CFM) Vs. External Static Pressure (in. W.C.)							
Model	Tap	0.5	0.1	0.3		0.7	0.9
S9X1D120U5PSBB S9B1D120U5PSAB S9X2D120U5PSBB	1	SCFM / Watts	707 / 46	443 / 55	179 / 64	-	-
	2	SCFM / Watts	1344 / 163	1218 / 183	1092 / 202	966 / 222	840 / 241
	3	SCFM / Watts	1532 / 225	1419 / 247	1307 / 268	1195 / 290	1083 / 312
	4	SCFM / Watts	1584 / 247	1477 / 270	1370 / 292	1263 / 315	1156 / 338
	5	SCFM / Watts	1915 / 401	1818 / 428	1722 / 454	1625 / 480	1529 / 506
	6	SCFM / Watts	2104 / 525	2016 / 553	1927 / 582	1839 / 610	1750 / 639
	7	SCFM / Watts	2132 / 546	2045 / 575	1958 / 604	1870 / 633	1783 / 662
	8	SCFM / Watts	2410 / 833	2328 / 868	2247 / 903	2165 / 937	2084 / 972
	9	SCFM / Watts	2472 / 909	2401 / 944	2329 / 979	2257 / 1013	2186 / 1048

Table 17. Downflow — models S9X1B040D3PSBB, S9B1B040D3PSAB, and S9X2B040D3PSBB

Furnace Airflow (CFM) Vs. External Static Pressure (in. W.C.)							
Model	Tap	0.5	0.1	0.3		0.7	0.9
S9X1B040D3PSBB S9B1B040D3PSAB S9X2B040D3PSBB	1	SCFM / Watts	378 / 28	153 / 32	-	-	-
	2	SCFM / Watts	514 / 35	330 / 45	145 / 55	-64	-74
	3	SCFM / Watts	765 / 69	618 / 81	471 / 93	324 / 105	178 / 116
	4	SCFM / Watts	827 / 81	691 / 94	554 / 106	418 / 119	281 / 132
	5	SCFM / Watts	988 / 124	879 / 140	770 / 156	661 / 171	553 / 187
	6	SCFM / Watts	1085 / 156	986 / 173	887 / 190	787 / 207	688 / 224
	7	SCFM / Watts	1125 / 170	1030 / 188	934 / 205	839 / 222	743 / 239
	8	SCFM / Watts	1129 / 170	1035 / 187	941 / 204	847 / 221	753 / 239
	9	SCFM / Watts	1492 / 369	1419 / 390	1346 / 411	1273 / 431	1200 / 452

Airflow Tables

Table 18. Downflow — models S9X1B060D3PSBB, S9B1B060D3PSAB, and S9X2B060D3PSBB

Furnace Airflow (CFM) Vs. External Static Pressure (in. W.C.)							
Model	Tap	0.5	0.1	0.3		0.7	0.9
S9X1B060D3PSBB S9B1B060D3PSAB S9X2B060D3PSBB	1	SCFM / Watts	624 / 47	451 / 57	277 / 68	104 / 79	-
	2	SCFM / Watts	866 / 89	734 / 102	602 / 116	470 / 129	338 / 142
	3	SCFM / Watts	949 / 113	833 / 128	718 / 142	602 / 156	486 / 171
	4	SCFM / Watts	1122 / 165	1025 / 182	928 / 200	831 / 217	733 / 235
	5	SCFM / Watts	1178 / 191	1087 / 209	996 / 227	905 / 246	814 / 264
	6	SCFM / Watts	1260 / 233	1180 / 252	1100 / 271	1021 / 290	941 / 309
	7	SCFM / Watts	1370 / 296	1299 / 316	1228 / 336	1158 / 355	1087 / 375
	8	SCFM / Watts	1480 / 365	1416 / 387	1352 / 408	1287 / 429	1223 / 450
	9	SCFM / Watts	1504 / 384	1440 / 406	1376 / 427	1312 / 449	1249 / 470

Table 19. Downflow — models S9X1B080D4PSBB, S9B1B080D4PSAB, and S9X2B080D4PSBB

Furnace Airflow (CFM) Vs. External Static Pressure (in. W.C.)							
Model	Tap	0.5	0.1	0.3		0.7	0.9
S9X1B080D4PSBB S9B1B080D4PSAB S9X2B080D4PSBB	1	SCFM / Watts	499 / 36	306 / 43	113 / 49	-	-
	2	SCFM / Watts	1017 / 143	922 / 158	828 / 173	734 / 188	640 / 203
	3	SCFM / Watts	1119 / 176	1029 / 192	940 / 207	850 / 223	761 / 239
	4	SCFM / Watts	1205 / 215	1125 / 233	1044 / 250	964 / 268	883 / 285
	5	SCFM / Watts	1237 / 231	1160 / 250	1083 / 268	1006 / 286	928 / 305
	6	SCFM / Watts	1378 / 315	1309 / 334	1240 / 354	1172 / 373	1103 / 393
	7	SCFM / Watts	1453 / 360	1389 / 380	1324 / 399	1260 / 419	1195 / 439
	8	SCFM / Watts	1618 / 496	1562 / 518	1505 / 540	1449 / 561	1392 / 583
	9	SCFM / Watts	1794 / 682	1742 / 704	1691 / 726	1639 / 748	1587 / 770

Table 20. Downflow — models S9X1C100D5PSBB, S9B1C100D5PSAB, and S9X2C100D5PSBB

Furnace Airflow (CFM) Vs. External Static Pressure (in. W.C.)							
Model	Tap	0.5	0.1	0.3		0.7	0.9
S9X1C100D5PSBB S9B1C100D5PSAB S9X2C100D5PSBB	1	SCFM / Watts	1002 / 103	823 / 117	644 / 130	465 / 144	285 / 157
	2	SCFM / Watts	1385 / 223	1276 / 243	1167 / 264	1057 / 284	948 / 304
	3	SCFM / Watts	1527 / 286	1430 / 310	1333 / 333	1236 / 357	1139 / 380
	4	SCFM / Watts	1610 / 328	1516 / 352	1421 / 377	1326 / 401	1231 / 425
	5	SCFM / Watts	1761 / 433	1677 / 459	1593 / 486	1509 / 512	1425 / 538
	6	SCFM / Watts	1861 / 492	1783 / 520	1706 / 549	1628 / 577	1551 / 605
	7	SCFM / Watts	1984 / 548	1902 / 577	1820 / 606	1738 / 635	1656 / 663
	8	SCFM / Watts	2173 / 728	2097 / 760	2020 / 792	1944 / 824	1867 / 856
	9	SCFM / Watts	2342 / 945	2269 / 973	2196 / 1002	2123 / 1031	2050 / 1060

Table 21. Downflow — models S9X1D120D5PSBB, S9B1D120D5PSAB, and S9X2D120D5PSBB

Furnace Airflow (CFM) Vs. External Static Pressure (in. W.C.)							
Model	Tap	0.5	0.1	0.3		0.7	0.9
S9X1D120D5PSBB S9B1D120D5PSAB S9X2D120D5PSBB	1	SCFM / Watts	680 / 47	419 / 56	159 / 66	-	-
	2	SCFM / Watts	1481 / 236	1372 / 259	1264 / 282	1155 / 304	1046 / 327
	3	SCFM / Watts	1566 / 268	1461 / 292	1357 / 316	1253 / 340	1149 / 363
	4	SCFM / Watts	1803 / 393	1711 / 420	1619 / 446	1527 / 472	1435 / 498
	5	SCFM / Watts	1891 / 445	1801 / 472	1711 / 500	1621 / 527	1532 / 555
	6	SCFM / Watts	2132 / 568	2025 / 601	1919 / 633	1812 / 666	1705 / 698
	7	SCFM / Watts	2154 / 644	2068 / 675	1982 / 705	1896 / 736	1810 / 766
	8	SCFM / Watts	2344 / 837	2267 / 870	2190 / 902	2113 / 934	2035 / 967
	9	SCFM / Watts	2414 / 896	2333 / 928	2251 / 961	2170 / 993	2088 / 1026

CFM Versus Temperature Rise

S9X1 and S9B1 furnaces have one stage heating.

S9X2 furnaces have two stage heating. First stage is low heating and second stage is high heating.

Table 22. Heating table - upflow

CFM VS. Temperature Rise																		
Model	CFM (Cubic Feet Per Minute)																	
	600	700	800	900	1000	1100	1200	1300	1400	1500	1600	1700	1800	1900	2000	2100	2200	2300
S9X1B040U3PSBB S9B1B040U3PSAB	60	51	45	40	36	33	30	—	—	—	—	—	—	—	—	—	—	—
S9X1B060U4PSBB S9B1B060U4PSAB	—	—	—	60	54	49	45	42	39	36	34	32	30	—	—	—	—	—
S9X1B080U4PSBB S9B1B080U4PSAB	—	—	—	—	72	65	60	55	51	48	45	—	—	—	—	—	—	—
S9X1C080U5PSBB S9B1C080U5PSAB	—	—	—	—	—	65	60	55	51	48	45	42	40	—	—	—	—	—
S9X1C100U5PSBB S9B1C100U5PSAB	—	—	—	—	—	—	—	68	63	59	55	52	49	47	44	42	40	—
S9X1D120U5PSBB S9B1D120U5PSAB	—	—	—	—	—	—	—	—	—	—	66	63	59	56	53	51	48	46

Table 23. Heating table - downflow

CFM VS. Temperature Rise																		
MODEL	CFM (Cubic Feet Per Minute)																	
	600	700	800	900	1000	1100	1200	1300	1400	1500	1600	1700	1800	1900	2000	2100	2200	2300
S9X1B040D3PSBB S9B1B040D3PSAB	60	51	45	40	36	33	30	—	—	—	—	—	—	—	—	—	—	—
S9X1B060D3PSBB S9B1B060D3PSAB	—	—	—	60	54	49	45	42	39	36	—	—	—	—	—	—	—	—
S9X1B080D4PSBB S9B1B080D4PSAB	—	—	—	—	71	64	59	55	51	47	—	—	—	—	—	—	—	—
S9X1C100D5PSBB S9B1C100D5PSAB	—	—	—	—	—	—	—	69	64	60	56	53	50	47	45	43	41	—
S9X1D120D5PSBB S9B1D120D5PSAB	—	—	—	—	—	—	—	—	—	71	66	63	59	56	53	51	48	46

Table 24. 2nd stage heating table - upflow

CFM VS. Upflow 1st Stage Temperature Rise																		
Model	CFM (Cubic Feet Per Minute)																	
	600	700	800	900	1000	1100	1200	1300	1400	1500	1600	1700	1800	1900	2000	2100	2200	2300
S9X2B040U3PSBB	60	51	45	40	36	33	30	—	—	—	—	—	—	—	—	—	—	—
S9X2B060U4PSBB	—	—	—	60	54	49	45	42	39	36	34	32	30	—	—	—	—	—
S9X2B080U4PSBB	—	—	—	—	72	65	60	55	51	48	45	—	—	—	—	—	—	—
S9X2C080U5PSBB	—	—	—	—	—	64	59	55	51	47	44	42	40	—	—	—	—	—
S9X2C100U5PSBB	—	—	—	—	—	—	—	69	64	60	56	53	50	47	45	43	41	—
S9X2D120U5PSBB	—	—	—	—	—	—	—	—	—	—	67	63	60	57	54	51	49	47

Table 25. 1st stage heating table - upflow

CFM VS. Upflow 2nd Stage Temperature Rise																		
Model	CFM (Cubic Feet Per Minute)																	
	500	600	700	800	900	1000	1100	1200	1300	1400	1500	1600	1700	1800	1900	2000	2100	2200
S9X2B040U3PSBB	47	39	34	29	26	—	—	—	—	—	—	—	—	—	—	—	—	—
S9X2B060U4PSBB	—	—	50	44	39	35	32	29	27	25	—	—	—	—	—	—	—	—
S9X2B080U4PSBB	—	—	—	58	52	47	43	39	36	34	31	—	—	—	—	—	—	—

CFM Versus Temperature Rise

Table 25. 1st stage heating table - upflow (continued)

CFM VS. Upflow 2nd Stage Temperature Rise																		
Model	CFM (Cubic Feet Per Minute)																	
	500	600	700	800	900	1000	1100	1200	1300	1400	1500		1600	1700	1800	1900	2000	2100
S9X2C080U5PSBB	—	—	—	58	51	46	42	39	36	33	31		—	—	—	—	—	—
S9X2C100U5PSBB	—	—	—	—	—	—	53	49	45	42	39		37	34	33	31	29	28
S9X2D120U5PSBB	—	—	—	—	—	—	—	58	54	50	47		44	41	39	37	35	34

Table 26. 2nd stage heating table – downflow

CFM VS. Downflow 2nd Stage Temperature Rise																			
Model	CFM (Cubic Feet Per Minute)																		
	600	700	800	900	1000	1100	1200	1300	1400	1500	1600	1700		1800	1900	2000	2100	2200	2300
S9X2B040D3PSBB	60	51	45	40	36	33	30	—	—	—	—	—	—	—	—	—	—	—	—
S9X2B060D3PSBB	—	—	—	59	53	48	44	41	38	36	—	—	—	—	—	—	—	—	—
S9X2B080D4PSBB	—	—	—	—	72	65	60	55	51	48	45	—	—	—	—	—	—	—	—
S9X2C100D5PSBB	—	—	—	—	—	—	—	68	63	59	55	52	49	47	44	42	40	—	—
S9X2D120D5PSBB	—	—	—	—	—	—	—	—	—	72	67	63	60	57	54	51	49	47	—

Table 27. 1st stage heating table – downflow

CFM VS. Downflow 1st Stage Temperature Rise																		
Model	CFM (Cubic Feet Per Minute)																	
	500	600	700	800	900	1000	1100	1200	1300	1400	1500		1600	1700	1800	1900	2000	2100
S9X2B040D3PSBB	47	39	34	29	26	—	—	—	—	—	—	—	—	—	—	—	—	—
S9X2B060D3PSBB	—	—	50	43	39	35	32	29	27	25	—	—	—	—	—	—	—	—
S9X2B080D4PSBB	—	—	—	58	52	47	43	39	36	34	31	—	—	—	—	—	—	—
S9X2C100D5PSBB	—	—	—	—	—	—	52	48	44	41	39	36	34	32	31	29	28	—
S9X2D120D5PSBB	—	—	—	—	—	—	—	58	54	50	47	44	41	39	37	35	33	—

Furnace General Installation

The following sections give general instructions for the installation of the gas furnaces.

Notes:

- For S9X2 furnaces, use a 5/16-inch Allen wrench to turn the four latches on the front panel a quarter turn.
- For S9X1 and S9B1 furnaces, use a 1/4-inch nut driver to remove the two screws on the front panel.

Horizontal Installation in an Attic or Crawlspace

The S-Series upflow condensing furnace may be installed in an attic or crawl space in the horizontal let or right position for needed airflow direction. The horizontal furnace installation in an attic should be on a service platform large enough to allow for proper clearances on all sides and service access to the front of the furnace. See “the Locations and Clearance section,” p. 23. Line contact is only permissible between lines formed by intersections of the top and two sides of the furnace casing and building joists, studs, or framing.

The furnace may be placed horizontally in a crawl space on a pad or other noncombustible material which will raise the unit for sufficient protection from moisture.

The Furnace must be supported at both ends and the middle when installed horizontally. The Furnace must also be elevated approximately 6 inches to allow clearance for the condensate drain to exit the cabinet in the *horizontal position*.

Figure 9. Horizontal installation in an attic or crawlspace

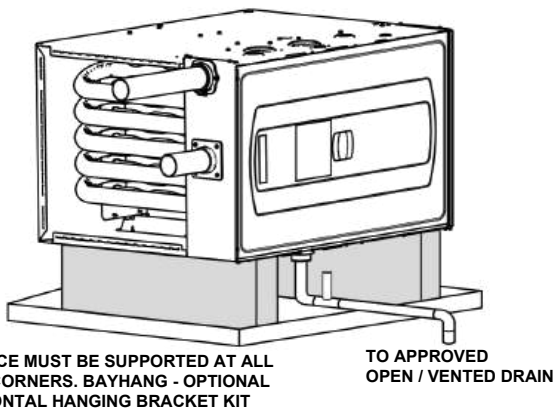

Note: The overflow stand pipe termination must be even with or slightly below the bottom of the condensate trap.
 Note: Water from the overflow pipe must drain into the emergency drain pan.

Horizontal Installation Hanging Using Straps

The furnace may be installed hanging in a horizontal position using straps. The furnace should be supported at both ends and have an additional support in the center of the furnace in front.

Figure 10. Horizontal installation hanging using straps

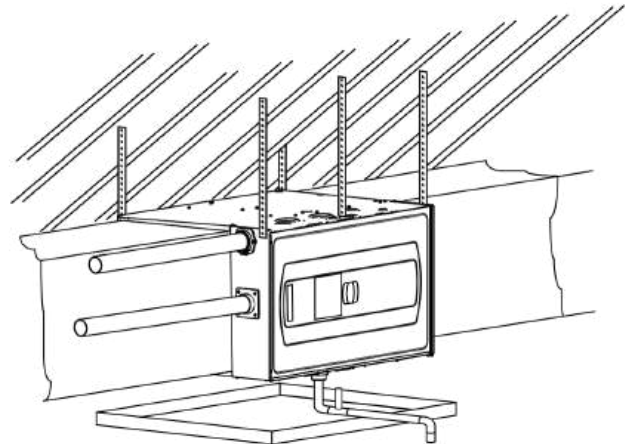

Gas Piping

Important: When converting the gas piping from the factory default, the plug must be removed from the new gas piping location and swapped with the grommet from the default location. The upflow furnace default is left side gas piping. The downflow furnace default is right side gas piping.

Figure 11. Upflow furnace with gas piping on left side

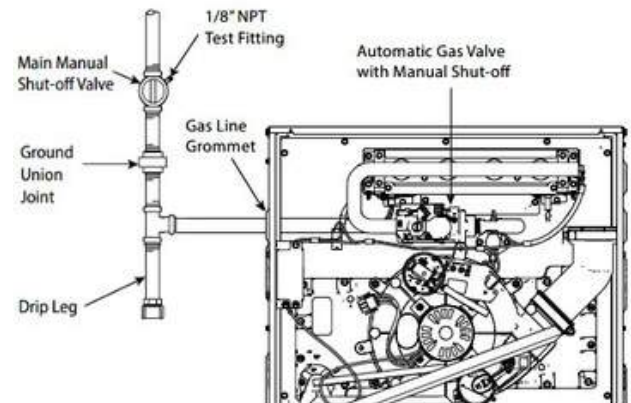

Furnace General Installation

Figure 12. Upflow furnace with gas piping on right side

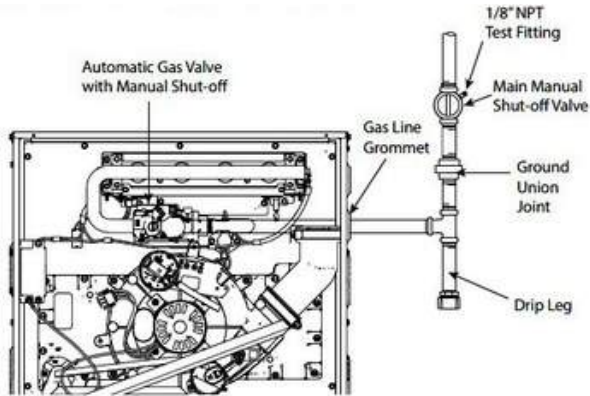

Figure 13. Downflow furnace with gas piping on left side

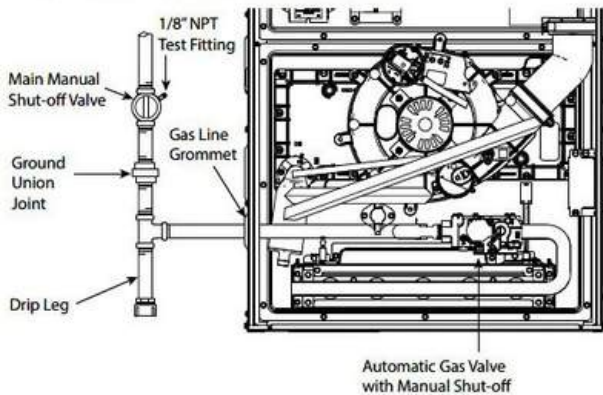

Figure 14. Downflow furnace with gas piping on right side

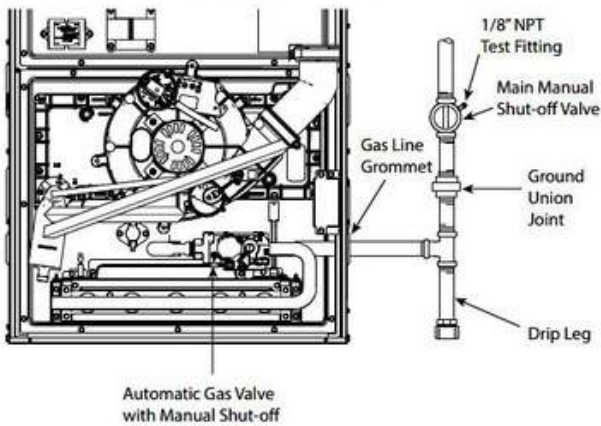

Figure 15. Horizontal left furnace with gas piping out left side

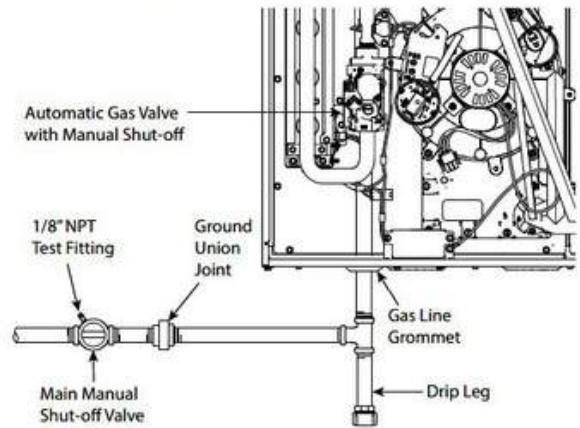

Figure 16. Horizontal left furnace with gas piping out right side

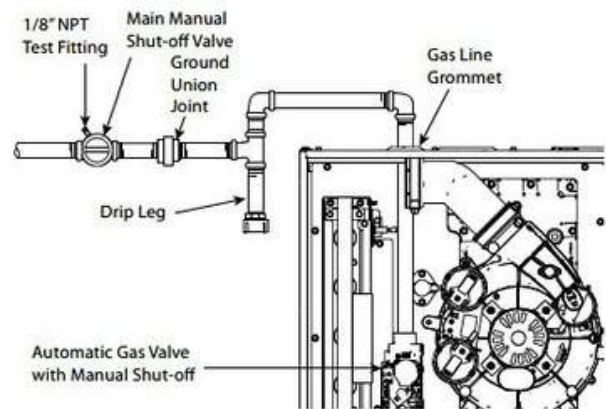

Figure 17. Horizontal right furnace with gas piping out left side

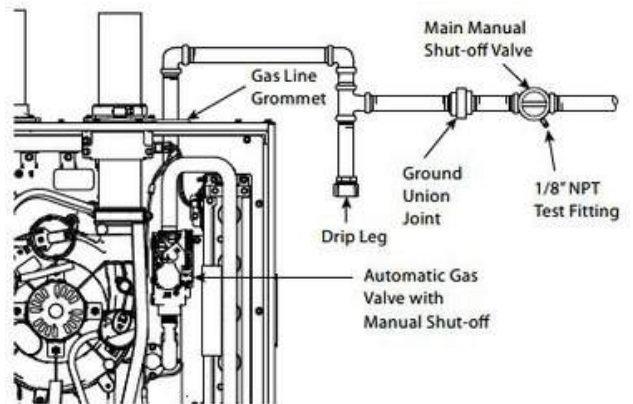
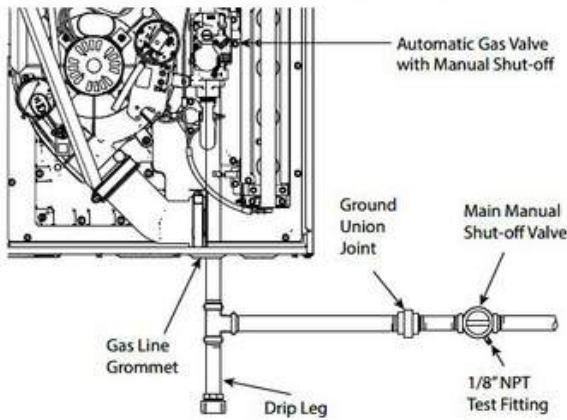

Figure 18. Horizontal right furnace with gas piping out right side



The upflow/horizontal furnace is shipped standard for left side installation of gas piping. An opening with plug is provided on the right side for an alternate gas piping arrangement.

The installation of piping shall be in accordance with piping codes and the regulations of the local gas company. Pipe joint compound must be resistant to the chemical reaction with liquefied petroleum gases.

Important: If local codes allow the use of flexible gas appliance connector, always use a new listed connector. Do not use a connector which has previously serviced another gas appliance.

Refer to the piping table for delivery sizes. Connect gas supply to the unit, using a ground joint union and a manual shut-off valve. National codes require a condensation drip leg to be installed ahead of the gas valve.

The furnace and its individual shut-off valve must be disconnected from the gas supply piping system during any pressure testing of that system at test pressures in excess of 1/2 psig (3.5 kPa).

The furnace must be isolated from the gas supply piping by closing its individual manual shut-off valve during any pressure testing of the gas supply piping system at test pressures equal to or less than 1/2 psig (3.5 kPa).

Note: Maximum pressure to the gas valve for natural gas is 13.8-inch W.C. Minimum pressure is 5.0-inch W.C. Maximum pressure to the gas valve for propane is 13.8-inch W.C. Minimum pressure is 11.0-inch W.C.

Table 28. Cubic feet per hour of gas for various pipe sizes and lengths (natural gas only)

Pipe Size	Length of Pipe						
	10	20	30	40	50	60	70
1/2	131	90	72	62	55	50	46
3/4	273	188	151	129	114	104	95
1	514	353	284	243	215	195	179
1-1/4	1060	726	583	499	442	400	368

Note: This table is based on Pressure Drop of 0.3 inch W.C. and 0.6 SP.GR. Gas

Note: All gas fittings must be checked for leaks using a soapy solution before lighting the furnace. Do not check with an open flame!

For propane conversions on all S-Series Furnaces, use BAYLPSS400* conversion kit with stainless steel burners.

When installing our furnaces in a manufactured house, use Manufactured Housing Accessory Kit, BAYMFGH200B.

Combustion and Input Check

1. Make sure all gas appliances are off except the furnace.
2. Clock the gas meter with the furnace operating (determine the dial rating of the meter) for one revolution.
3. Match the "Sec" column in the gas flow table with the time clocked.
4. Read the "Flow" column opposite the number of seconds clocked.
5. Use the following factors if necessary:
 - a. For 1 Cu.Ft. Dial Gas Flow CFH = Chart Flow Reading ÷ 2
 - b. For 1/2 Cu.Ft. Dial Gas Flow CFH = Chart Flow Reading ÷ 4
 - c. For 5 Cu.Ft. Dial Gas Flow CFH = 10 X Chart Flow Reading ÷ 4
6. Multiply the final figure by the heating value of the gas obtained from the utility company and compare to the nameplate rating. This must not exceed the nameplate rating.

Table 29. Gas flow in cubic feet per hour, 2 cubic foot dial

Sec.	Flow	Sec.	Flow	Sec.	Flow	Sec.	Flow
10	732	31	236	52	141	86	85
11	666	32	229	53	138	88	83
12	610	33	222	54	136	90	81
13	563	34	215	55	133	94	78
14	523	35	209	56	131	98	75
15	488	36	203	57	128	100	73
16	458	37	198	58	126	104	70
17	431	38	193	59	124	108	68
18	407	39	188	60	122	112	65
19	385	40	183	62	118	116	63
20	366	41	179	64	114	120	61
21	349	42	174	66	111	130	56
22	333	43	170	68	108	140	52
23	318	44	166	70	105	150	49
24	305	45	163	72	102	160	46
25	293	46	159	74	99	170	43

Furnace General Installation

Table 29. Gas flow in cubic feet per hour, 2 cubic foot dial (continued)

Sec.	Flow	Sec.	Flow	Sec.	Flow	Sec.	Flow
26	282	47	156	76	96	180	41
27	271	48	153	78	94	190	39
28	262	49	149	80	92	200	37
29	253	50	146	82	89	—	—
30	244	51	144	84	87	—	—

Gas Valve Adjustment

Changes can be made by adjusting the manifold pressure, or changing orifices (orifice change may not always be required). To adjust the manifold pressure:

1. Turn off all electrical power to the system.
2. Loosen (Do not remove) the pressure tap test setscrew one turn with 3/32-inch hex wrench.
 - a. The pressure tap adjustment kit (KIT07611) contains a 3/32-inch hex wrench, a 5/16-inch hose and a connector and can be ordered through Global Parts.
3. Attach a manifold pressure gauge with flexible tubing to the outlet pressure boss marked OUT P.
4. Turn on system power with no call for heat. For single stage furnaces, skip to [Step 7](#).

Note: 2nd stage manifold pressure should be adjusted first. To shorten the amount of time it takes for 2nd stage to be energized, set the ISD (Interstage Delay) to zero (000) using the Menu and Option buttons on the IFC. This will energize 2nd stage heating immediately after the blower on delay from 1st stage is complete. This is ~30 seconds after 1st stage flame has been sensed.

5. Make a call for 2nd stage heating. Insure that the unit is in 2nd stage heating by verifying 24 VAC is measured between C and HI on the gas valve.

Important: Adjust 2nd stage on the gas valve before attempting to adjust 1st stage.

6. Adjust 2nd stage gas heat by removing the high (HI) adjustment regulator cover screw.
 - a. To increase outlet pressure, turn the regulator adjust screw clockwise.
 - b. To decrease outlet pressure, turn the regulator adjust screw counterclockwise.
 - c. Adjust regulator until pressure shown on manometer matches the pressure specified in the table.

The input of no more than nameplate rating and no less than 93% of the nameplate rating, unless the unit is derated for high altitude.
 - d. Replace and tighten the regulator cover screw securely.

- e. Remove call for second stage heat, first stage heat is now running.

7. Adjust 1st stage gas heat by removing the low (LO) adjustment regulator cover screw. For single stage furnaces, refer to top figure and remove the outlet regulator cover screw.
 - a. To increase outlet pressure, turn the regulator adjust screw clockwise.
 - b. To decrease outlet pressure, turn the regulator adjust screw counterclockwise.
 - c. Adjust regulator until pressure shown on manometer matches the pressure specified in the table.

The input of no more than nameplate rating and no less than 93% of the nameplate rating, unless the unit is derated for high altitude.
 - d. Replace and tighten the regulator cover screw securely.
8. Cycle the valves several times to verify regulator setting.
 - a. Repeat steps [Step 5](#) to [Step 7](#), if needed.
9. Turn off all electrical power to the system.
10. Remove the manometer and flexible tubing and tighten the pressure tap screw.
11. Using a leak detection solution or soap suds, check for leaks at the pressure outlet boss and pressure tap test screw.
12. Turn on system power and check operation of the unit.

Figure 19. Single-stage gas valve

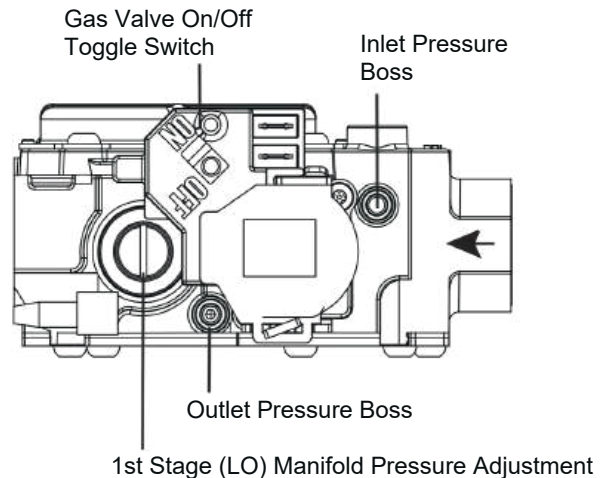

Figure 20. Two-stage gas valve

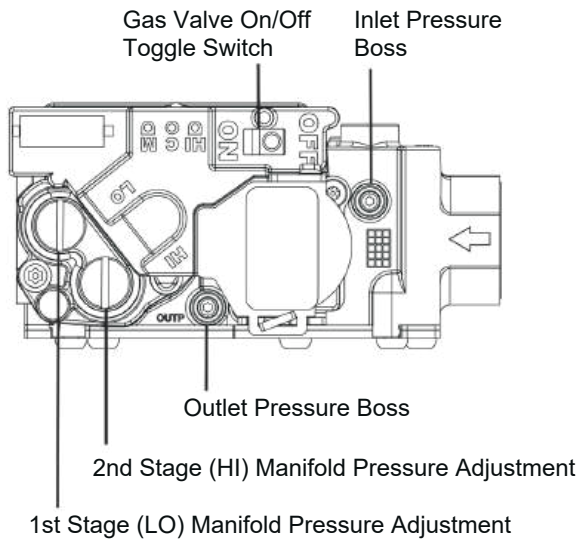

Table 30. Maximum and minimum inlet pressure (inches w.c.)

	Natural Gas	Propane Gas
Maximum	13.8	13.8
Minimum	5	11
Maximum and Minimum Fuel Manifold Pressure Settings (inches w.c.) 2nd Stg/1st Stg		
All models (S9X1, S9B1, S9X2) Orifice sizes for Natural Gas and Propane	3.5/1.7	10/6
All models (S9X1, S9B1, S9X2)	45	56

High Altitude Derate

Input ratings (BTUH) of these Furnaces are based on sea level operation and should not be changed at elevations up to 2,000 ft. (610 m).

If the installation is 2,000 ft. (610 m) or above, the Furnace input rate (BTUH) shall be reduced 4% for each 1,000 ft. above sea level.

Installations of this furnace at altitudes above 2,000 ft. (610 m) shall be made utilizing the Vent Length table and/or Part Numbers for Replacement Orifices table in these installation instructions.

The Furnace input rate shall be checked by clocking the gas flow rate (CFH) and multiplying by the heating value obtained from the local utility supplier for the gas being delivered at the installed altitude. Input rate changes can

be made by adjusting the Manifold Pressure (min 3.0 - max 3.7 in. W.C. - Natural Gas) or changing orifices (orifice change may not always be required).

If the desired input rate can not be achieved with a change in Manifold Pressure, then the orifices must be changed. Propane installations will require an orifice change.

Important: Reinstall the replacement orifices to the same depth as the orifices supplied with the equipment.

See the table for help in selecting orifices if orifice change is required. Furnace input rate and temperature rise should be checked again after changing orifices to confirm the proper rate for the altitude.

The vent length table shows the required vent lengths for installations at various altitudes. Optional high altitude kits are available for installations over 5000 feet. Installations above 12,000 feet are not allowed.

Turn the main Gas Valve toggle switch within the unit to the "OFF" position. Turn the external gas valve to "ON". Purge the air from the gas lines. After purging, check all gas connections for leaks with a soapy solution – Do not check with an open flame. Allow 5 minutes for any gas that might have escaped to dissipate.

Propane Gas being heavier than air may require forced ventilation. Turn the toggle switch on the Gas Valve in the unit to the "ON" position.

Table 31. Part numbers for replacement orifices

Drill Size	Part Number	Drill Size	Part Number
44	ORF00501	54	ORF00555
45	ORF00644	55	ORF00693
47	ORF00910	56	ORF00907
49	ORF00503	58	ORF01338
—	—	59	ORF01339

Note: If 46, 48, 50, or 57 orifice is required, use the next smaller drill size and reduce the manifold pressure to achieve rate.

The table lists the main burner orifices used with the furnace. If a change of orifices is required to correct the furnace input rating refer to the part number for replacement orifices table.

Installation of this furnace at altitudes above 2000 ft (610m) shall be in accordance with local codes, or in the absence of local codes, the *National Fuel Gas Code, ANSI Z223.1/ NFPA 54* or *National Standard of Canada, Natural Gas and Propane Installation Code, CSA B149.1*. Installation of this furnace at altitudes above 2,000 ft (610 m) shall be made in accordance with the listed high altitude conversion kit available with the furnace.

Furnace General Installation

Table 32. Main burner orifices

Orifice Twist Drill Size If Installed at Sea Level	Altitude Above Sea Level and Orifice Required at Other Elevations								
	2000	3000	4000	5000	6000	7000	8000	9000	10000
42	42	43	43	43	44	44	45	46	47
43	44	44	44	45	45	46	47	47	48
44	45	45	45	46	47	47	48	48	50
45	46	47	47	47	48	48	49	49	50
46	47	47	47	48	48	49	49	50	51
47	48	48	49	49	49	50	50	51	52
54	54	55	55	55	55	55	56	56	56
55	55	55	55	56	56	56	56	56	57
56	56	56	57	57	57	58	59	59	60
57	58	59	59	60	60	61	62	63	63
58	59	60	60	61	62	62	63	63	64

Note: From National Fuel Gas Code — Table E.1.1(d)

General Venting

Furnace exhaust must be vented to the outdoors. These furnaces are induced draft vented and must not be connected to any vent serving another appliance. Please note that these furnaces use positive-pressure vent systems.

Proper venting is essential to obtain maximum efficiency from a condensing furnace. Proper installation of the vent system is necessary to assure drainage of the condensate and prevent deterioration of the vent system.

ETL has certified the design of condensing furnaces for a minimum of 0-inch clearance from combustible materials to single wall plastic vent pipe.

The recommended system is assembled from 2-inch or 3-inch plastic pipe and fittings found in the . Where the system is routed to the outdoors through an existing masonry chimney containing flue products from another gas appliance, or where required by local codes, then 3-inch venting of Type 29- 4C stainless steel must be used in place of PVC material.

These Furnaces have been classified as Category IV Furnaces in accordance with ANSI Z21.47 “latest edition” standards. Category IV - a central furnace that operates with a positive vent static pressure and with a flue loss less than 17 percent. These conditions require special venting systems, which must be gas tight and water tight.

Note: When an existing Furnace is removed from a venting system serving other gas appliances, the venting system is likely to be too large to properly vent the remaining attached appliances.

Important:

- These Furnaces may be installed as Direct Vent (sealed combustion) or as Nondirect Vent (single pipe). The Furnaces are shipped Direct Vent with sealed combustion.
- Products installed in Canada must use vent systems that are certified to the Standard for Type BH Gas Venting Systems (ULC S636) for Class II-A venting systems (up to 65°C). Components of the vent system must not be interchanged with other vent systems or unlisted pipe or fittings. Plastic components, specified primers, and glues must be from a single system manufacturer and not intermixed with other system manufacturer's vent system parts. In addition, the first three feet of the vent pipe must be visible for inspection.

When the vent pipe is exposed to temperatures below freezing, that is, when it passes through unheated spaces, the pipe must be insulated with 1/2-inch (12.7 mm) thick Armaflex-type insulation or equal.

If the space is heated sufficiently to prevent freezing, then the insulation will not be required. If domestic water pipes are not protected from freezing then the space meets the condition of a heated space.

3-Inch Venting Requirements

Important:

- To determine if your application requires 3-inch venting, see the “Maximum Vent Length Table,” p. 48.
- Horizontal venting application must use the 2-inch x 3-inch offset reducing coupling. Vertical venting applications do not require the reducing coupling to be offset.

Notes:

- If your furnace comes with a factory supplied 2-inch x 3-inch offset reducing coupling it is used for 3-inch vent pipe installation. Make sure the marking “TOP” is located on the top side of the pipe in horizontal venting applications. The straight side of the coupling must be on bottom for proper drainage of condensate.
- For Canadian applications, BAYREDUCE 2-inch x 3-inch offset reducing coupling meets ULC-S636 requirements. Make sure the marking “TOP” is located on the top side of the pipe. The straight side of the coupling must be on bottom for proper drainage of condensate in horizontal venting.

Figure 21. Horizontal coupling

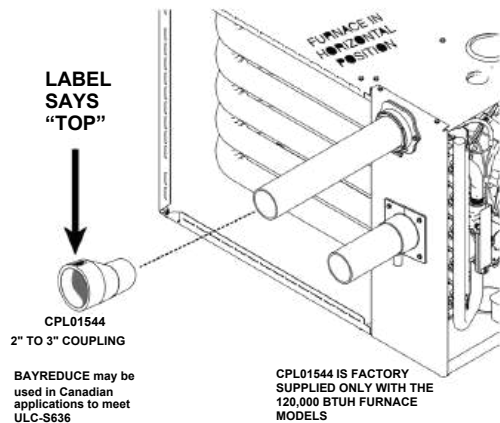
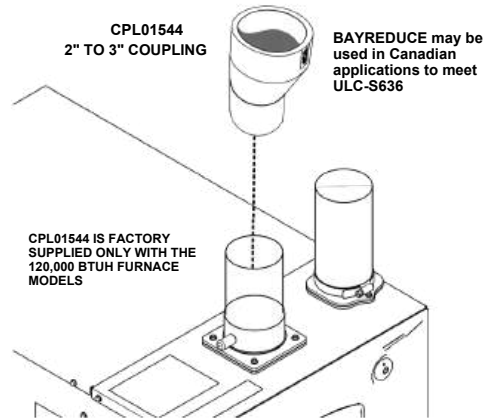

Figure 22. Vertical coupling



Typical Venting

This combustion air intake has a built-in condensate collection system. Condensate that may collect is drained by field supplied 1/2-inch ID tubing. The tubing must be routed to form a trap and water seal (see Figure 24, p. 44, Figure 25, p. 44, and Figure 26, p. 44).

A field supplied hose clamp is recommended but not be required. The tubing is not under pressure.

Combustion air piping must be square cut and de-burred for proper drainage. For side entry combustion inlet applications, ensure the drain is pointed downwards.

Figure 23. Condensing furnace vent design



Condensing Furnace Vent Design

Figure 24. Upflow top entry

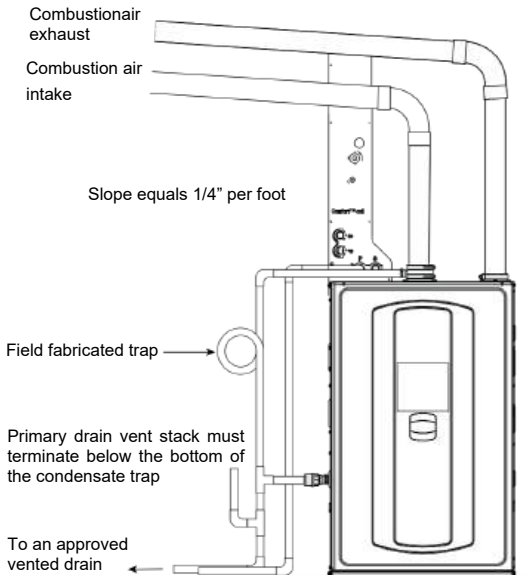

Figure 25. Horizontal top entry

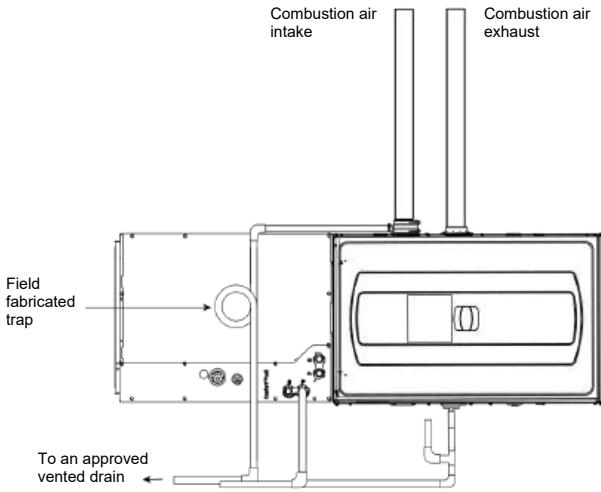
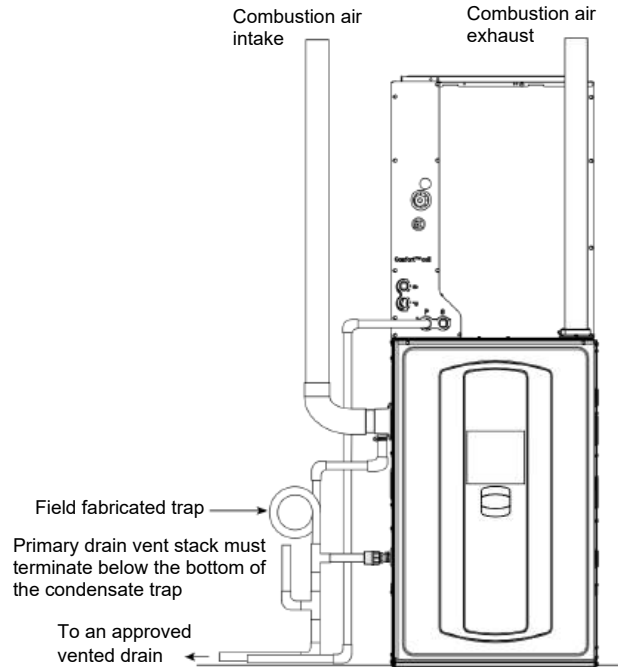

Figure 26. Upflow side entry



Note: Primary drain vent stack must terminate below the bottom of the condensate trap.

Special Case Venting

Below are instructions for direct vent furnace air intake.

In certain applications, particularly when the furnace is located in a basement, there are certain conditions that can be met where warm humid air from the outside is drawn into combustion air piping. If the area where the piping is located is conditioned below 70° F, condensation could occur inside the piping and ultimately drain into the furnace compartment, which could lead to premature component failure.

Note: Inlet air piping is not considered to be part of the venting system. The inlet air piping may be made from PVC.

We recommend following one of the options to prevent this condition from occurring and possibly damaging components within the furnace:

Option 1

If possible, slope the inlet combustion air piping away from the furnace. Condensation that may occur will now drain outside of the home. The combustion air outlet piping must remain sloped back to the furnace.

Note: Combustion air drain fitting must remain capped if not using the drain function. See [“Condensate Drain Instructions,” p. 69 section.](#)

Figure 27. Option 1

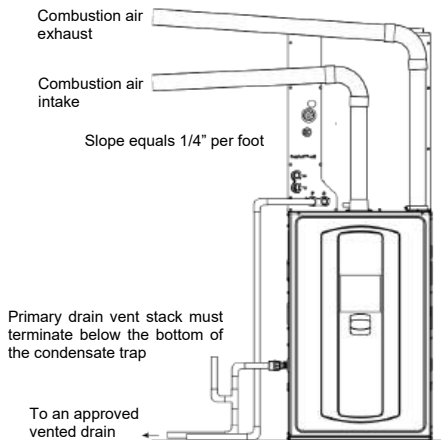

Option 2 - Top combustion air intake

If sloping the combustion air intake pipe is not possible, install a DWV Tee as close to the furnace as possible with drain and trap to prevent condensation from occurring in the furnace cabinet. Do not tee AC condensate and combustion air condensate trap together.

Note: Combustion air drain fitting must remain capped if not using the drain function. See “Condensate Drain Instructions,” p. 69 section.

Figure 28. Option 2

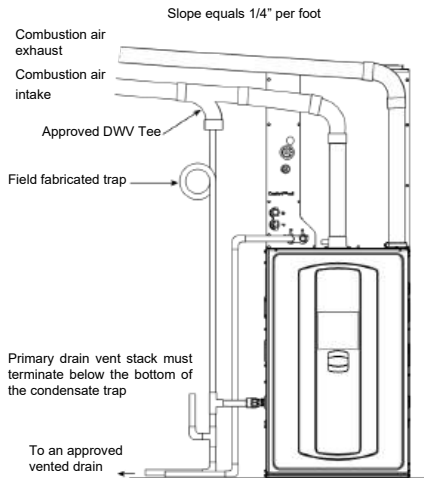

Option 3 - Side combustion air intake

If sloping the combustion air intake pipe is not possible, install an approved DWV Tee as close to the furnace as possible with drain and trap.

Note: Combustion air drain fitting must remain capped if not using the drain function. See “Condensate Drain Instructions,” p. 69 section.

Figure 29. Option 3

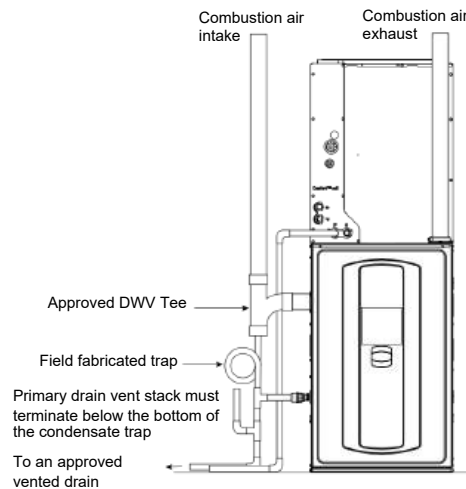

Vent Terminations

Direct Vent Application: The Furnaces must be vented to the exterior of the house and combustion air must come through the inlet air pipe from outside air.

Note: BAYVENT* accessories can be used for inlet and outlet terminals when the pipes do not exit the structure together. For Canadian applications, venting systems must meet ULC-S636 requirements.

Non-direct Vent Application: The Furnace shall be vented to the exterior of the house, but combustion air may enter from the surrounding area as long as combustion air requirements are met. (See “Air for Combustion and Ventilation,” p. 56)

Vent terminations.

- BAYVENT200B
- BAYAIR30AVENTA

Vent terminations — Canadian applications. Meets ULC-S636 requirements.

- BAYVENTCN200B
- BAYAIR30CNVENT

Furnace Vent / Inlet Pipe Installation in Two Pressure Zone Configurations are not allowed

Note: For single pressure zone applications, see the Horizontal Venting section.

The following are Examples Only.

Example 1

Example 1 shows the vent pipe exhausting through the roof and the inlet air coming from the interior of the house. The inlet air coming from the interior of the house must meet combustion requirements for area, etc., as shown in the section “Air for Combustion and Ventilation,” p. 56 in this document.

Furnace General Installation

Note: If only the flue gas pipe is to the outside of the structure, a straight section of pipe (long enough to exit the Furnace cabinet) must be attached to the inlet air side with an elbow (which is 5 to 10 equiv. ft.) installed on the end to prevent dust and debris from falling directly into the Furnace.

Figure 30. Example 1

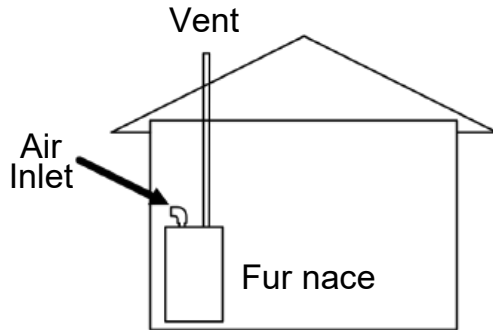

Example 2

The inlet air does not have to come from outside the structure. Example 2 shows the inlet air, may come from the attic if the requirements for combustion air are met as shown in the section "Air for Combustion and Ventilation," p. 56.

Note: If only the flue gas pipe is to the outside of the structure, a straight section of pipe (long enough to exit the Furnace cabinet) must be attached to the inlet air side with an elbow (which is 5 to 10 equiv. ft.) installed on the end to prevent dust and debris from falling directly into the Furnace.

Figure 31. Example 2

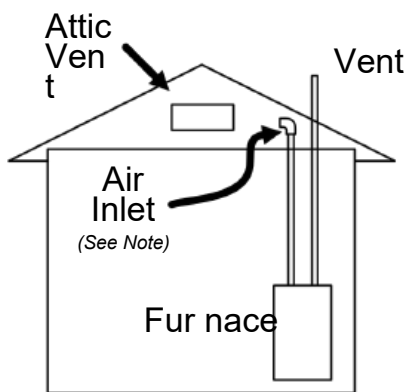

Attaching Vent Piping

Vent Fitting Material – Plastic

Gas and liquid tight single wall vent fittings, designed for resistance to corrosive flue condensate, MUST be used throughout.

Listed in the Approved Vent Pipe Materials table are designations for different types of 2-inch and 3-inch size pipe and fittings that meet these requirements. The materials listed are various grades of PVC, CPVC, ABS,

PolyPro® by DuraVent, Z-Dens by Novaflex Group, Innoflue® by Centrotherm, ECCO™ polypropylene venting system, and PolyFlue™ polypropylene venting systems.

Attaching Vent Piping

Important: Products installed in Canada must use vent systems that are certified to the Standard for Type BH Gas Venting Systems (ULC S636) for Class II-A venting systems (up to 65°C). Components of the vent system must not be interchanged with other vent systems or unlisted pipe or fittings. Plastic components, specified primers, and glues must be from a single system manufacturer and not intermixed with other system manufacturer's vent system parts. In addition, the first three feet of the vent pipe must be visible for inspection.

Pipe Joints

All joints must be fastened and sealed per manufacturer instructions and local and national codes to prevent escape of combustion products into the building.

Manufactured Modular Venting Systems

⚠ WARNING

Carbon Monoxide Poisoning!

Failure to follow instructions below could result in death or serious injury, or property damage. Refer to the Approved Vent Pipe Materials table for manufactured modular venting systems approved for use with this product. Follow the manufacturer's installation instructions when installing the venting system.

⚠ WARNING

Carbon Monoxide Poisoning!

Failure to follow instructions below could result in death or serious injury, or property damage. Do not use cement on polypropylene venting systems. Follow the manufacturer's installation instructions when installing the venting system.

Important: For manufactured modular venting systems that are approved with this product see PVC vent fitting material table. Do not drill into polypropylene venting pipes.

Bonding of PVC

Note: It is recommended that the first joints from the Furnace be connected and sealed with high temperature RTV. This will enable the pipes to be removed later without cutting.

Be sure to properly support these joints.

Commercially available solvent cement for PVC must be used to join PVC pipe fittings. Follow instructions on container carefully.

Pipe and Fitting – ASTM D1785, D2466, D2661, and D2665

PVC Primer and Solvent Cement – ASTM D2564

Procedure for Cementing Joints – Ref ASTM D2855

1. Cut pipesquare,removeraggededgesandburrs. Chamfer end of pipe, then clean fitting socket and pipe joint area of all dirt, grease, moisture or chips.
2. Aftercheckingpipeandsocketforproperfit,wipe socket and pipe with cleaner-primer. Apply a liberal coat of primer to inside surface of socket and outside of pipe.
DO NOT ALLOW PRIMER TO DRY BEFORE APPLYING CEMENT.
3. Applyathincoatofcementevenlyinthesocket. Quickly apply a heavy coat of cement to the pipe end and insert pipe into fitting with a slight twisting movement until it bottoms out.
4. Holdthepipeinthefittingfor30secondstoprevent tapered socket from pushing the pipe out of the fitting.
5. Wipeallexcesscementfromthejointwitharag.Allow 15 minutes before handling. Cure time varies according to fit, temperature and humidity.

Connection of the pipe and collar of the combustion air inlet should just be a friction fit. It is recommended that the inlet

air joint be sealed with RTV type sealant to allow the joint to be separated for possible future service. The inlet and vent pipes must be properly supported throughout the entire length.

Note: Follow venting instructions carefully when using PVC cement.

Important: All joints must be water tight. Flue condensate is somewhat acidic, and leaks can cause equipment damage.

Figure 32. Sealing inlet air pipe

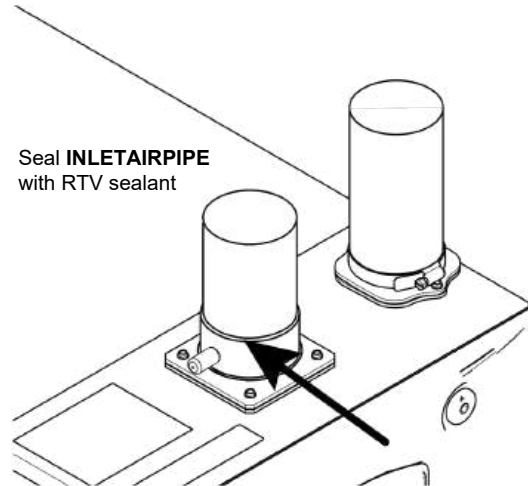

Table 33. Approved vent pipe materials

Vent Fitting Material			
ANSI/UL 1738 APPROVED VENT PIPE MATERIAL			
ASTM STANDARD	PIPETYPE	ALLOWABLETEMPERATURE°F	MARKING
N/A	N/A	158	UL 1738
PVC			
ASTM STANDARD	PIPE TYPE	ALLOWABLE TEMPERATURE °F	MARKING
D2665	DWV PIPE	158	ASTM D2665
D1785	SCH 40, 80, 120	158	ASTM 1785
D2241	SDR SERIES	158	ASTM D2241
CPVC			
ASTMSTANDARD	PIPETYPE	ALLOWABLETEMPERATURE°F	MARKING
D2846	CPVC41	212	ASTMD2846
F441	SCH40,80	212	ASTMF441
F442	SDRSERIES	212	ASTMF442
ABS			
ASTMSTANDARD	PIPETYPE	ALLOWABLETEMPERATURE°F	MARKING
D2661	SCH40DWV	180	ASTMD2661
PolyPro® by DuraVent, Z-Dens by Novaflex Group, Innoflue® by Centrotherm, System 1738 by IPEX, ECCO™ polypropylene venting system, and PolyFlue™ polypropylene venting systems.			
ASTMSTANDARD	PIPETYPE	ALLOWABLETEMPERATURE°F	MARKING
N/A	N/A	230	ULC-S636

Note: These fittings are available from your Gas Furnace Distributors.

Maximum Vent Length Table

Table 34. Maximum vent length — S9*1/S9X2

Model	Maximum Total Equivalent Length In Feet for Vent and Inlet Air (See Notes)	
	2Inchor2.5InchPipe	3Inchor4InchPipe
Altitude 0–2,000 Feet		
S9*1B040U3PS / S9X2B040U3PS, S9*1B040D3PS / S9X2B040D3PS, S9*1B060D3PS / S9X2B060D3PS, S9*1B060U4PS / S9X2B060U4PS	200	200
S9*1B080U4PS / S9X2B080U4PS, S9*1B080D4PS / S9X2B080D4PS, S9*1C080U5PS / S9X2C080U5PS	100	200
S9*1C100U5PS / S9X2C100U5PS, S9*1C100D5PS / S9X2C100D5PS	50	200
S9*1D120U5PS / S9X2D120U5PS, S9*1D120D5PS / S9X2D120D5PS	(a)	200
Altitude 2,001–5,400 Feet		
S9*1B040U3PS / S9X2B040U3PS, S9*1B040D3PS / S9X2B040D3PS, S9*1B060D3PS / S9X2B060D3PS, S9*1B060U4PS / S9X2B060U4PS	200	200
S9*1B080U4PS / S9X2B080U4PS, S9*1B080D4PS / S9X2B080D4PS, S9*1C080U5PS / S9X2C080U5PS	80	120
S9*1C100U5PS / S9X2C100U5PS, S9*1C100D5PS / S9X2C100D5PS	50	150
S9*1D120U5PS / S9X2D120U5PS, S9*1D120D5PS / S9X2D120D5PS	(a)	200
Altitude 5,401–7,800 Feet		
S9*1B040U3PS / S9X2B040U3PS, S9*1B040D3PS / S9X2B040D3PS, S9*1B060D3PS / S9X2B060D3PS, S9*1B060U4PS / S9X2B060U4PS	100	150
S9*1B080U4PS / S9X2B080U4PS, S9*1B080D4PS / S9X2B080D4PS, S9*1C080U5PS / S9X2C080U5PS	50	70
S9*1C100U5PS / S9X2C100U5PS, S9*1C100D5PS / S9X2C100D5PS	(a)	100
S9*1D120U5PS / S9X2D120U5PS, S9*1D120D5PS / S9X2D120D5PS	(a)	100
Altitude 7,801–10,100 Feet		
S9*1B040U3PS / S9X2B040U3PS, S9*1B040D3PS / S9X2B040D3PS, S9*1B060D3PS / S9X2B060D3PS, S9*1B060U4PS / S9X2B060U4PS	50	90
S9*1B080U4PS / S9X2B080U4PS, S9*1B080D4PS / S9X2B080D4PS, S9*1C080U5PS / S9X2C080U5PS	(a)	50
S9*1C100U5PS / S9X2C100U5PS, S9*1C100D5PS / S9X2C100D5PS	(a)	50
S9*1D120U5PS / S9X2D120U5PS, S9*1D120D5PS / S9X2D120D5PS	(a)	50

Notes:

- For PolyPro® by Duravent, Z-DENS by Novaflex Group, InnoFlue® by Centrotherm, ECCO™ polypropylene venting system, and Polyflue™ manufactured modular venting systems that are in the approved vent pipe material table, fitting equivalent vent lengths may be different from what is shown in Note 5. Refer to the venting system manufacturer’s installation instruction for appropriate venting diameters and equivalent lengths.
- Minimum vent length for all models: 15ft equivalent.
- Do not mix pipe diameters in the same length of pipe outside the furnace cabinet (except adapters at the top of the furnace). If different inlet and vent pipe sizes are used, the vent pipe must adhere to the maximum length limit shown in the table above (See Note 6 below for exception). The inlet pipe can be of a larger diameter, but never smaller than the vent pipe.
- Maximum pipe lengths must not be exceeded. The length shown is not a combined total, it is the maximum length of each (Vent or Inlet air pipes).
- One short radius 90° elbow is equivalent to 10ft of 4-inch pipe, 10ft of 3-inch pipe, or 8ft of 2-inch pipe. One long radius elbow is equivalent to 6ft of 4-inch pipe, 7ft of 3-inch pipe, or 5ft of 2-inch pipe. Two 45° elbows equal one 90° long elbow. One mitered elbow is equivalent to 12ft of 3-inch pipe or 12ft of 2-inch pipe.
- The termination tee or bend must be included in the total number of elbows. If the BAYAIR30AVENTA or BAYAIR30CNVENT termination kit is used, the equivalent length of pipe is 5 feet. For BAYVENT200B and BAYVENTCN200B the equivalent length is 0 feet.
- For Canadian applications, venting systems must meet ULC-S636 requirements.
- The inlet air of one pipe systems require the installation of a minimum of one 90° elbow (to prevent dust and debris from falling straight into the furnace).
- * represents X or B

(a) Not allowed.

Horizontal Venting

Note: Confirm the vent piping is sloped 1/4-inch per foot and that piping is supported properly to prevent sags and condensate pooling.

3-inch Venting requirements

Important:

- To determine if your application requires 3-inch venting, see the "Maximum Vent Length Table," p. 48
- Horizontal venting application must use the 2-inch x 3-inch offset reducing coupling. Vertical venting applications do not require the reducing coupling to be offset.

When the vent pipe is exposed to temperatures below freezing, (for example when it passes through unheated spaces), the pipe must be insulated with 1/2-inch (12.7 mm) thick Armaflex-type insulation or equal.

If the space is heated sufficiently to prevent freezing, then the insulation will not be required. If domestic water pipes are not protected from freezing then the space meets the condition of a heated space.

Note: If your furnace comes with a factory supplied 2-inch x 3-inch offset reducing coupling it is used for 3-inch vent pipe installation. Make sure the marking "TOP" is located on the top side of the pipe in horizontal venting applications. The straight side of the coupling must be on bottom for proper drainage of condensate.

Figure 33. Horizontal venting

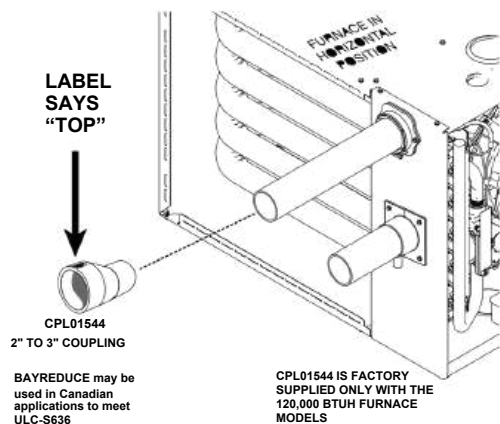

Note: For Canadian applications, BAYREDUCE 2-inch x 3-inch offset reducing coupling meets ULC-S636 requirements. Make sure the marking "TOP" is located on the top side of the pipe. The straight side of the coupling must be on bottom for proper drainage of condensate in horizontal venting.

Figure 34. Vertical venting

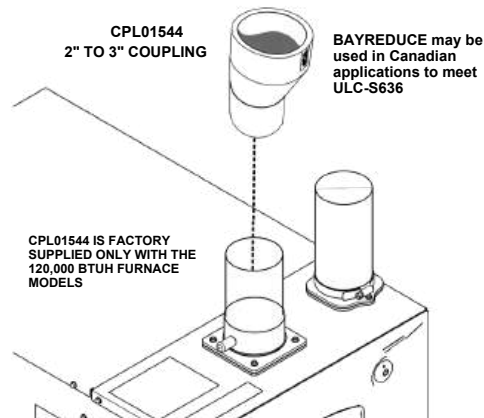

Combustible Material Wall

A minimum clearance of 1-inch to combustible materials must be maintained when using single wall stainless steel venting.

Shield material to be a minimum of 24 gauge stainless or aluminized sheet metal. Minimum dimensions are 12-inch x 12-inch. Shield must be fastened to both inside and outside of wall. Use screws or anchor type fasteners suited to the outside or inside wall surfaces.

Figure 35. Combustible material wall

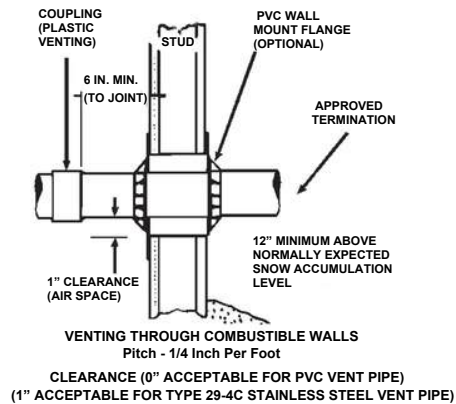

Non-combustible Material Wall

The hole through the wall must be large enough to maintain pitch of vent and properly seal.

Use cement mortar seal on inside and outside of wall.

Furnace General Installation

Figure 36. Non-combustible material wall

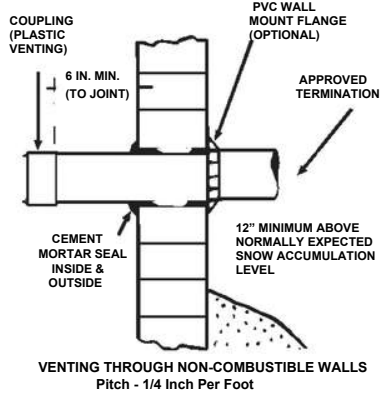

Horizontal Venting Through Wall

The vent for this appliance shall not terminate:

- Over public walkways.
- Near soffit vents or crawl space vents or other areas where condensate or vapor could create a nuisance or hazard or cause property damage.
- Where condensate vapor could cause damage or could be detrimental to the operation of regulators, relief valves, or other equipment.

Possible configurations for two pipe venting systems are located in the same pressure zone.

Important: Maintain 12-inch minimum clearance above highest anticipated snow level or grade, whichever is greater.

Note: All distances are center line to center line.

Figure 37. Configurations one pipe venting systems — type 1

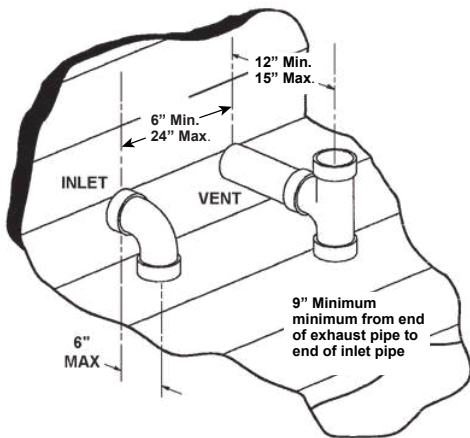

Figure 38. Configurations one pipe venting systems — type 2

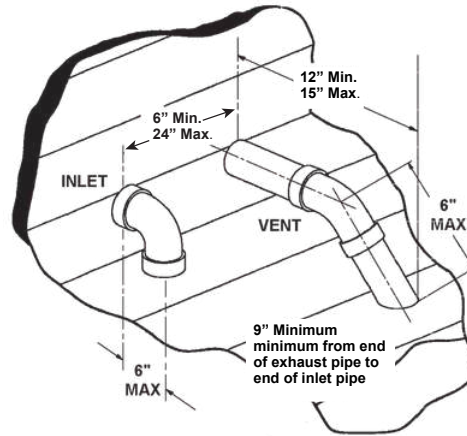

Figure 39. Configurations one pipe venting systems — type 3

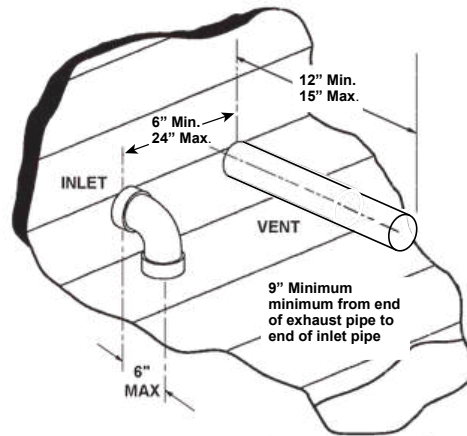

Figure 40. Configurations one pipe venting systems — type 4

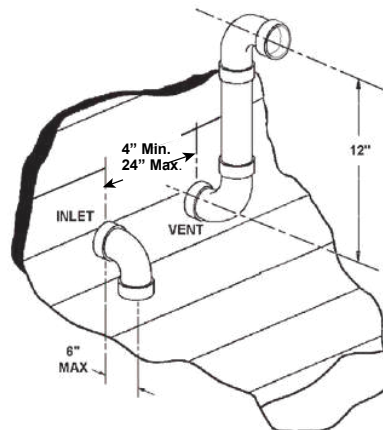

Figure 41. Configurations one pipe venting systems — type 5

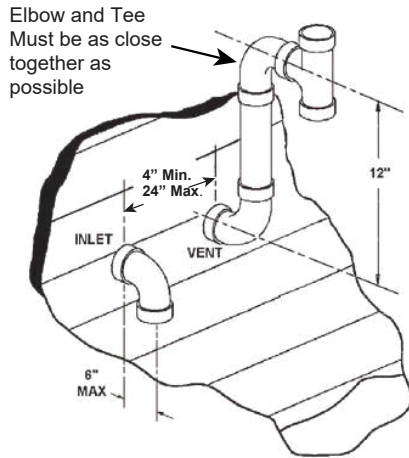
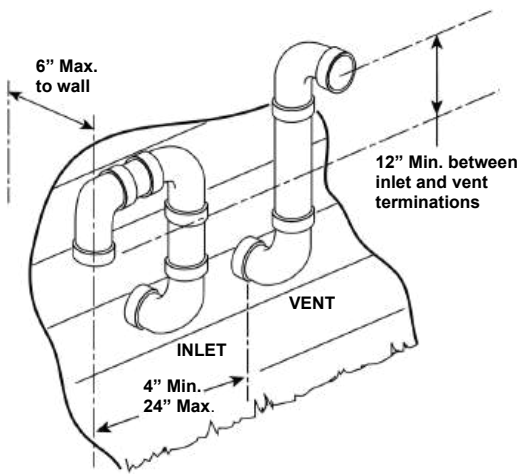

Figure 42. Configurations one pipe venting systems — type 6



Horizontal Venting Through Wall with Concentric Vent Kit

These Furnaces may be installed as direct vent (as shipped) or as nondirect vent. Installation must conform to national, state, and local codes.

The BAYVENT200B, BAYVENTCN200B, BAYAIR30AVENTA, and BAYAIR30CNVENT vent & inlet terminals kits must be located at least 12-inch minimum above normally expected snow accumulation level.

Avoid areas where staining or condensate drippage may be a problem.

Location of the vent/wind terminal should be chosen to meet the requirements for either direct or non-direct vent applications.

Pitch — Venting through the wall must maintain 1/4-inch per foot pitched upward to insure that condensate drains back to the Furnace.

Flue Gas Degradation — The moisture content of the flue gas may have a detrimental effect on some building materials.

This can be avoided by using the roof or chimney venting option. When wall venting is used on any surface that can be affected by moisture, it is recommended that a corrosion resistant shield (24 inches square) be used behind the vent terminal.

This shield can be wood, plastic, sheet metal, etc. Also, silicone caulk all cracks, seams and joints within 3 feet of the vent terminal.

The vent for this appliance shall not terminate

1. Overpublicwalkways;or
2. Nearsoffitventsorcrawlspac ventsorotherareas where condensate or vapor could create a nuisance or hazard or cause property damage; or
3. Wherecondensatevaporcouldcausedamageorcould be detrimental to the operation of regulators, relief valves. or other equipment.

For Canadian installations, if you used a ULC-S636 approved manufactured modular venting system, a copy of the manufacturer's instructions should remain with the system.

The installation instruction can be obtained from the vent termination manufacturer. BAYVENTCN200B and BAYAIR30CNVENT meet ULC-S636 requirements.

Note: For Canadian applications, horizontal vent termination kits must meet ULC-S636..

Figure 43. BAYVENT200B / BAYVENTCN200B

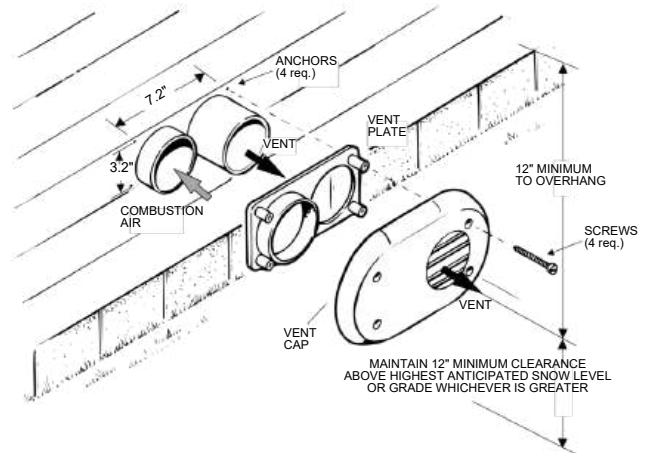

Furnace General Installation

Figure 44. BAYAIR30AVENTA/BAYAIR30CNVENT (Sidewall)

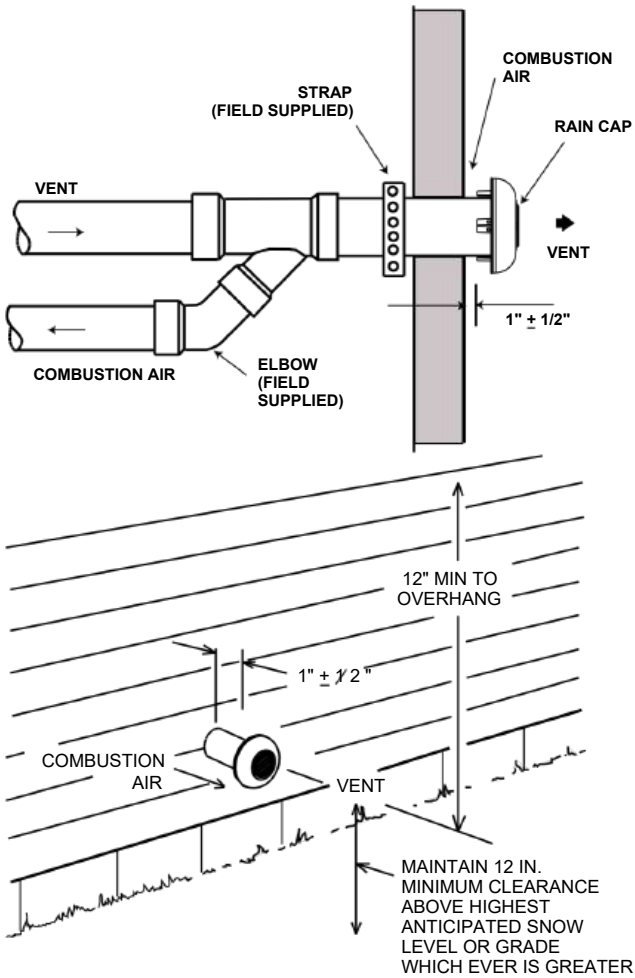

Important: The Commonwealth of Massachusetts requires compliance with regulation 248 CMR 4.00 and 5.00 for installation of through-the-wall vented gas appliances as follows:

For all side wall horizontally vented gas fueled equipment installed in every dwelling, building or structure used in whole or in part for residential purposes, including those owned or operated by the Commonwealth and where the side wall exhaust vent termination is less than seven (7) feet above finished grade in the area of the venting, including but not limited to decks and porches, the following requirements shall be satisfied:

- 1. Installation of carbon monoxide detectors**—At the time of installation of the side wall horizontal vented gas fueled equipment, the installing plumber or gasfitter shall observe that a hard wired carbon monoxide detector with an alarm and battery back-up is installed on the floor level where the gas equipment is to be

installed. In addition, the installing plumber or gasfitter shall observe that a battery operated or hard wired carbon monoxide detector with an alarm is installed on each additional level of the dwelling, building or structure served by the side wall horizontal vented gas fueled equipment. It shall be the responsibility of the property owner to secure the services of qualified licensed professionals for the installation of hard wired carbon monoxide detectors.

- In the event that the sidewall horizontally vented gas fueled equipment is installed in a crawl space or an attic, the hard wired carbon monoxide detector with alarm and battery back-up may be installed on the next adjacent floor level.
- In the event that the requirements of this subdivision can not be met at the time of completion of installation, the owner shall have a period of thirty (30) days to comply with the above requirements; provided, however, that during said thirty (30) day period, a battery operated carbon monoxide detector with an alarm shall be installed.

- 2. Approved carbon monoxide detectors**—Each carbon monoxide detector as required in accordance with the above provisions shall comply with NFPA 72 and be ANSI/UL 2034 listed, IAS 6-96 certified or CSA 6.19.
- 3. Signage.** A metal or plastic identification plate shall be permanently mounted to the exterior of the building at a minimum height of eight (8) feet above grade directly in line with the exhaust vent terminal for the horizontally vented gas fueled heating appliance or equipment. The sign shall read, in print size no less than one-half (1/2) inch in size, "Gas Vent Directly Below. Keep Clear of all Obstructions".
- 4. Inspection.** The state or local gas inspector of the side wall horizontally vented gas fueled equipment shall not approve the installation unless, upon inspection, the inspector observes carbon monoxide detector(s) and signage installed in accordance with the provisions of 248 CMR 9.1.23 and 12.9.7 respectively.

This appliance requires a special venting system. If BAYAIR30AVENTA or BAYVENT200B are used, a copy of the installation instructions for the kit shall remain with the appliance or equipment at the completion of installation. The venting system installation instructions can be obtained from the manufacturer by writing to the following address:

Trane and American Standard
6200 Troup Highway
Tyler, TX 75707
Attention: Manager of Field Operations Excellence

Horizontal Vent Clearances

Figure 45. Horizontal vent clearances

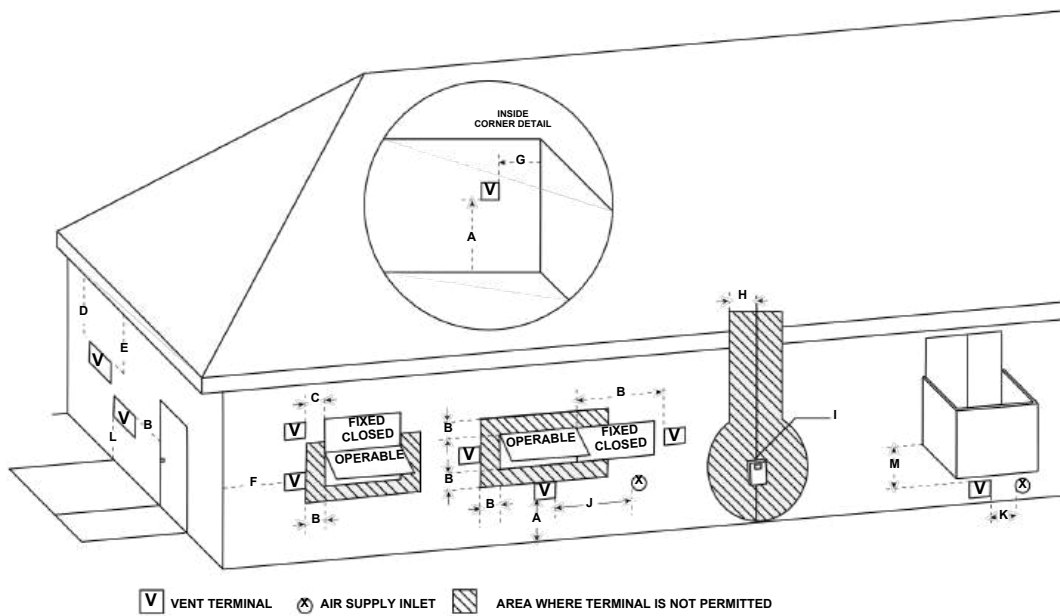

Table 35. Vent termination clearances - direct/non-direct

Vent Termination Clearances- Direct/Non-Direct				
		Canadian Installations	US Installations Non-Direct	US Installations Direct
A=	Clearance above grade, veranda, porch, deck, or balcony	12 inches (30 cm)		
B=	Clearance to window or door that may be opened	12 inches (30 cm) for appliances > 10,000 BTUH (3 kw) and ≤ 100,000 BTUH (30 kw), 36 inches (91 cm) for appliances > 100,000 BTUH (30 kw)	4 feet (1.2m) below or to the side of opening; 1 foot (0.3m) above opening	9 inches (23 cm) for appliances > 10,000 BTUH (3 kw) and ≤ 50,000 BTUH (15 kw), 12 inches (30 cm) for appliances > 50,000 BTUH (15 kw)
C=	Clearance to permanently closed window	(a)	(a)	(a)
D=	Vertical clearance to ventilated soffit located above the terminal within a horizontal distance of 2 feet (61 cm) from the center line of the terminal	(a)	(a)	(a)
E=	Clearance to unventilated soffit	(a)	(a)	(a)
F=	Clearance to outside corner	(a)	(a)	(a)
G=	Clearance to inside corner	(a)	(a)	(a)
H=	Clearance to each side of center line extended above meter/regulator assembly	3 feet (91 cm) with a height 15 feet (4.5 m) above the meter/regulator assembly	(a)	(a)
I=	Clearance to service regulator vent outlet	3 feet (91 cm)	(a)	(a)
J=	Clearance to nonmechanical air supply inlet to building or the combustion air inlet to any other appliance	12 inches (30 cm) for appliances > 10,000 BTUH (3 kw) and ≤ 100,000 BTUH (30 kw), 36 inches (91 cm) for appliances > 100,000 BTUH (30 kw)	4 feet (1.2 m) below or to side of opening; 1 foot (300 m) above opening	9 inches (23 cm) for appliances > 10,000 BTUH (3 kw) and ≤ 50,000 BTUH (15 kw); 12 inches (30 cm) for appliances > 50,000 BTUH (15 kw)
K=	Clearance to a mechanical air supply inlet	6 feet (1.83m)	3 feet (91 cm) above if within 10 feet (3m) horizontally	3 feet (91 cm) above if within 10 feet (3m) horizontally

Furnace General Installation

Table 35. Vent termination clearances - direct/non-direct (continued)

Vent Termination Clearances- Direct/Non-Direct				
		Canadian Installations	US Installations Non-Direct	US Installations Direct
L=	Clearance above a paved sidewalk or paved driveway located on public property	7 feet (2.13 m) and not located above public walkways or other areas where condensate or vapor can cause a nuisance or hazard		
M=	Clearance under veranda, porch, deck, or balcony	12 inches (30 cm) if veranda, porch, deck, or balcony is fully open on a minimum of two sides beneath the floor	12 inches (30 cm) where the area beneath the veranda, porch, deck, or balcony is open on not less than two sides. The vent terminal is prohibited in this location where only one side is open	

Notes:

1. The Canadian venting installations must be in accordance with local codes or in the absence of local codes with the current CSAB149.1 Natural Gas and Propane Installation Code.
2. The US venting installations must be in accordance with local codes or in the absence of local codes with the current ANSI Z223.1/NFPA54 National Fuel Gas Code.

(a) Clearance in accordance with local installation codes and the requirements of the gas supplier.

Venting through the Roof

Support Horizontal pipe every 3-inch with the first support as close to the furnace as possible. Induced draft blower, housing, and furnace must not support the weight of the flue pipe.

Figure 46. Supports

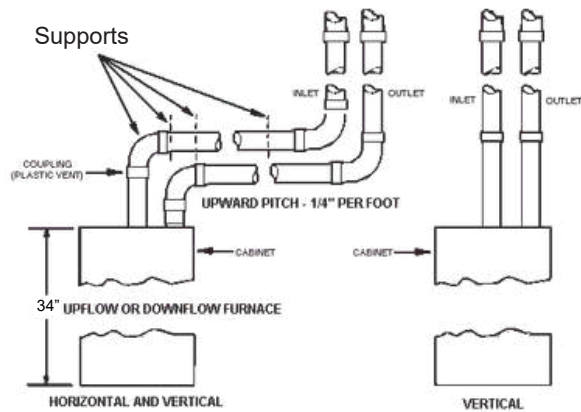
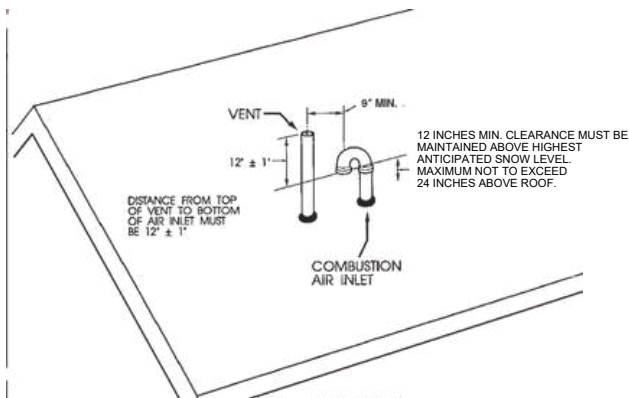

Figure 47. Pipe roof vents



Note: All measurements are from center line to center line.

Figure 48. BAYAIR30AVENTA/BAYAIR30CNVENT

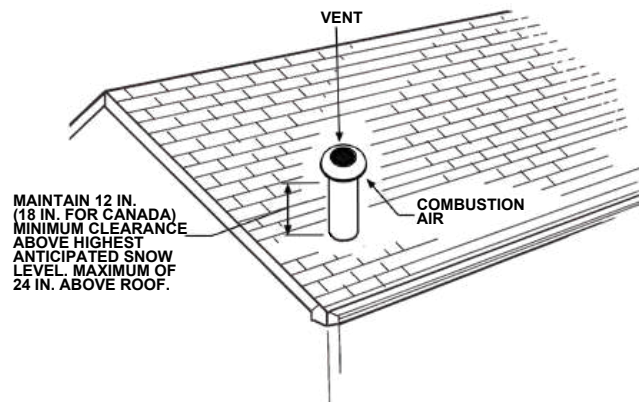
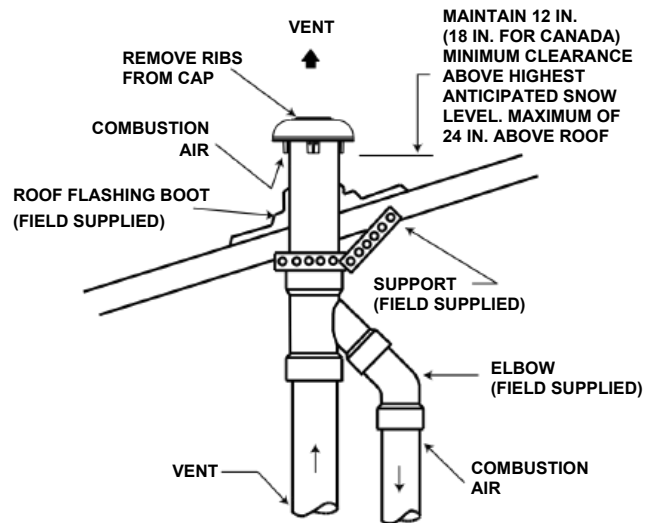

Figure 49. BAYAIR30AVENTA/BAYAIR30CNVENT



When penetrating roof with PVC vent pipe, a flexible flashing may be used for a weather tight seal. Lubricate flexible seal on flashing before PVC pipe is pushed through the seal. (Field Supplied)

Notes:

- No vent cap is the preferred method for vertical vent termination in extremely cold climates.
- In extreme climate conditions, insulate the exposed pipe above the roof line with Armaflex type insulation.

Figure 50. Venting through ceiling

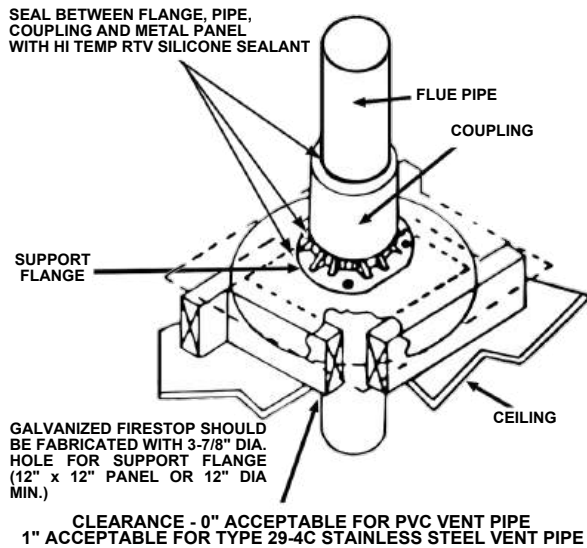
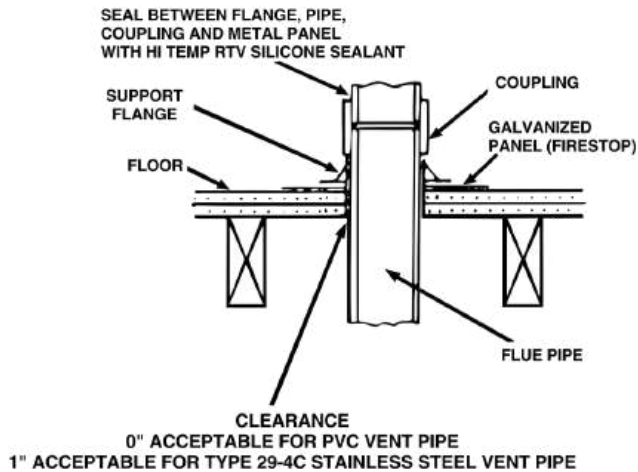

Figure 51. Venting through floor



Venting Through an Unused Chimney / Venting Routed Through a Masonry Chimney

Important:

- Refer to Section 12.6.8 of NFPA 54 / ANSI 223.1 when routing vent piping through a chimney.
- The single wall flue pipe joints must be sealed. The 90° elbow connection to vertical pipe must be sealed to prevent condensate leakage to base of masonry chimney.

Figure 52. PVC plastic venting through unused chimney

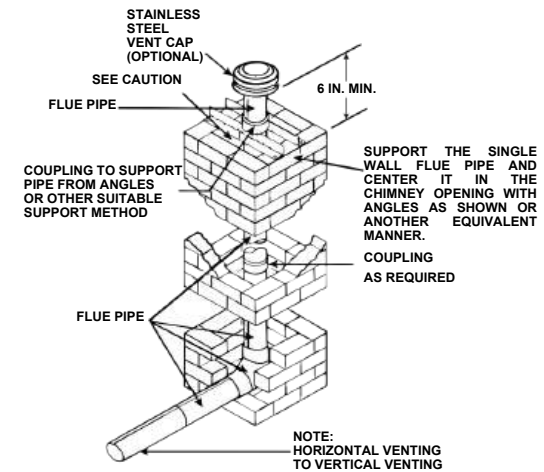

Venting Through an Unused Chimney

Important:

- Refer to Section 12.6.8 of NFPA 54 / ANSI 223.1 when routing vent piping through a chimney.
- The single wall flue pipe joints must be sealed. The 90° elbow connection to vertical pipe must be sealed to prevent condensate leakage to base of masonry chimney.

Vent Fitting Material – Stainless Steel

Gas and liquid tight single wall metal vent fitting, designed for resistance to corrosive flue condensate such as Type 29-4C MUST be used throughout.

These fittings and fitting accessories are to be field supplied.

Direction of Stainless Steel Fitting

All stainless steel fitting must be installed with male end towards the Furnace.

All horizontal stainless steel sections must be positioned with the seam on top.

All long horizontal sections must be supported to prevent sagging.

All pipe joints must be fastened and sealed to prevent escape of combustion products into the building.

Figure 53. Type 29-4C stainless steel venting through unused chimney

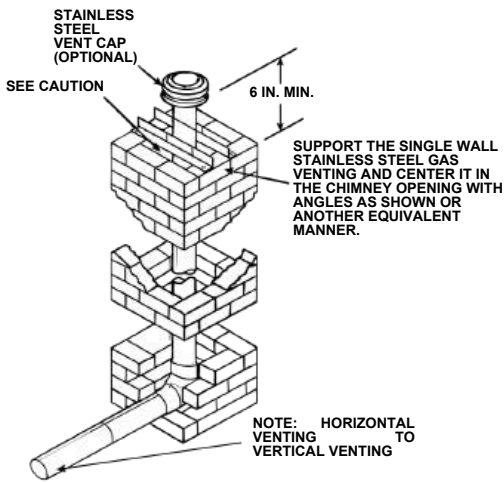

Downward Venting

Furnace may be in vertical or horizontal configuration.

Notes:

1. Condensate trap for vent pipe must be a minimum of 6 inches in height.
2. Condensate trap for vent and inlet pipe must be connected into a condensate drain pump; an open or vented drain; or it can be connected to the outlet hose of the Furnace condensate trap. Outdoor draining of the Furnace and coil condensate is permissible if allowed by local codes.
3. The condensate trap should be primed at initial start up prior to heating season operation.

Figure 54. Downward venting

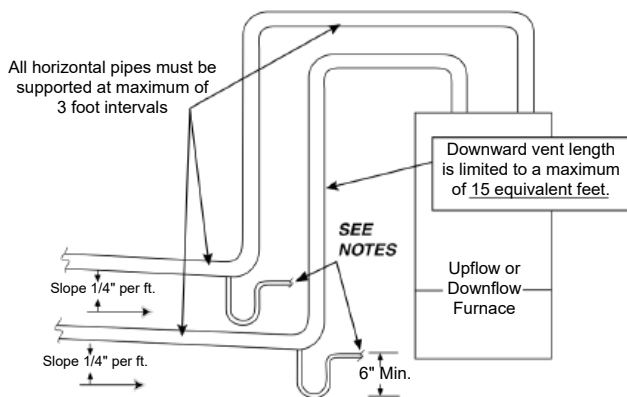

Important: Caution should be taken to prevent drains from freezing or causing slippery conditions that could lead to personal injury. Excessive draining of condensate may cause saturated ground conditions that may result in damage to plants.

Air for Combustion and Ventilation

Adequate flow of combustion and ventilating air must not be obstructed from reaching the Furnace. Air openings provided in the Furnace casing must be kept free of obstructions which restrict the flow of air. Airflow restrictions affect the efficiency and safe operation of the Furnace. Keep this in mind should you choose to remodel or change the area which contains your Furnace. Furnaces must have a free flow of air for proper performance.

Provisions for combustion and ventilation air shall be made in accordance with "latest edition" of Section 9.3, Air for Combustion and Ventilation, of the National Fuel Gas Code, ANSI Z223.1 / NFPA 54, or Sections 8.2, 8.3 or 8.4 of CSA B149.1 Installation Codes, and applicable provisions of the local building codes. Special conditions created by mechanical exhausting of air and fireplaces must be considered to avoid unsatisfactory Furnace operation.

Furnace location may be in an unconfined space or a confined space.

Unconfined space are installations with 50 cu. ft. or more per 1000 BTU/hr input from all equipment installed. Unconfined spaces are defined in the table and illustration for various furnace sizes. These spaces may have adequate air by infiltration to provide air for combustion, ventilation, and dilution of flue gases. Buildings with tight construction (for example, weather stripping, heavily insulated, caulked, vapor barrier, etc.), may need additional air provided as described for confined space.

Table 36. Minimum area in square feet for unconfined space installations

Furnace Maximum BTUH Input Rating	With 8 Ft. Ceiling Minimum Area in Square Feet of Unconfined Space
40,000	250
60,000	375
80,000	500
100,000	625
120,000	750

Figure 55. Unconfined space

50 CU. FT. OR MORE PER 1000 BTU/HR INPUT ALL EQUIP. INSTALLED

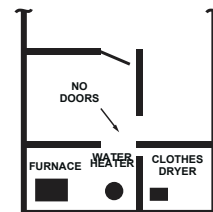

Confined spaces are installations with less than 50 cu. ft. of space per 1000 BTU/ hr input from all equipment installed. Confined spaces are defined in the table and illustration for

various furnace sizes. Air for combustion and ventilation requirements can be supplied from inside the building.

The following types of installations will require use of OUTDOOR AIR for combustion, due to chemical exposures:

- Commercial buildings
- Buildings with indoor pools
- Furnaces installed in commercial laundry rooms
- Furnaces installed near chemical storage areas

Exposure to the following substances in the combustion air supply will also require OUTDOOR AIR for combustion:

- Permanent wave solutions
- Chlorinated waxes and cleaners
- Chlorine based swimming pool chemicals
- Water softening chemicals
- Deicing salts or chemicals
- Carbon Tetrachloride
- Halogen type refrigerants
- Cleaning solvents (such as perchloroethylene)
- Printing inks, paint removers, varnish, etc.
- Hydrochloric acid
- Cements and glues
- Antistatic fabric softeners for clothes dryers
- Masonry acid washing material

Note: Extended warranties are not available in some instances. Extended warranty does not cover repairs to equipment installed in establishments with corrosive atmospheres, including but not limited to, dry cleaners, beauty shops, and printing facilities.

Table 37. Minimum free area in square inches each opening (furnace only) in a confined space

Furnace Max BTUH Input Rtg.	Air From Inside	Air From Outside	
		Vertical Duct (a)	Horizontal Duct (b)
40,000	100	10	20
60,000	100	15	30
80,000	100	20	40
100,000	100	25	50
120,000	120	30	50

(a) 1 Square inch per 4000 BTU/hr Vertical Duct.
 (b) 1 Square inch per 2000 BTU/hr Horizontal Duct.

Figure 56. Confined space

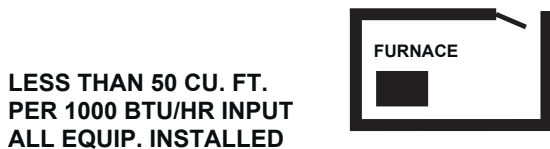

All air from inside the building — The confined space shall be provided with two permanent openings communicating directly with an additional room(s) of sufficient volume so that the combined volume of all spaces meets the criteria for an unconfined space. The total input of all gas utilization equipment installed in the combined space shall be considered in making this determination. Refer to the Minimum Free Area in square inches for confined spaces table, for minimum open areas required.

Figure 57. Air from inside building

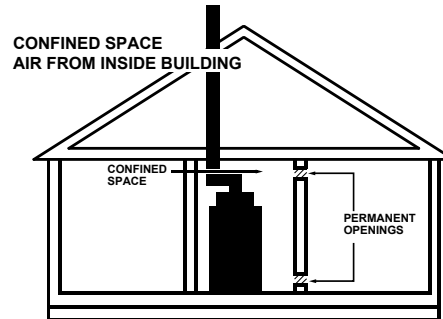

All air from outdoors — The confined space shall be provided with two permanent openings, one commencing within 12 inches of the top and one commencing within 12 inches of the bottom of the enclosure.

The openings shall communicate directly, or by ducts, with the outdoors or spaces (crawl or attic) that freely communicate with the outdoors. Refer to the Minimum Free Area in square inches for confined spaces table, for minimum open areas required.

Figure 58. Air from outdoors

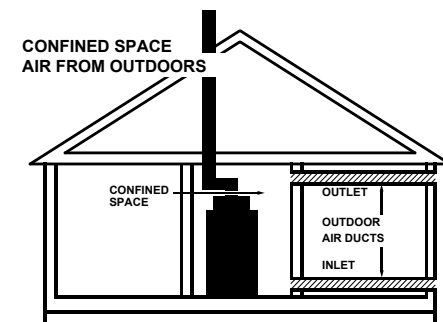
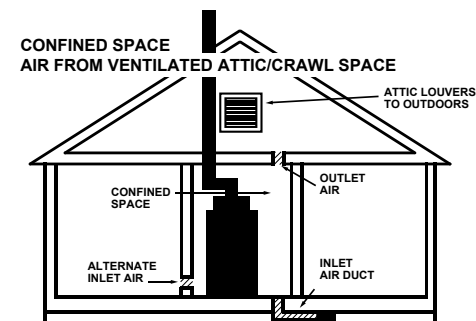
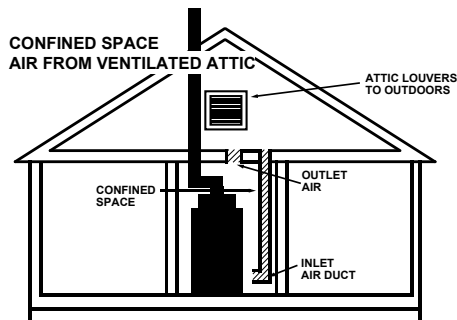

Figure 59. Air from ventilated attic/crawl space



Furnace General Installation

Figure 60. Air from ventilated attic



Duct Connections

Air duct systems should be installed in accordance with standards for air conditioning systems, National Fire Protection Association Pamphlet No. 90. They should be sized in accordance with ACCA Manual D or whichever is applicable. Check on controls to make certain they are correct for the electrical supply.

Central furnaces, when used in connection with cooling units, shall be installed in parallel or on the upstream side of the cooling units to avoid condensation in the heating element, unless the furnace has been specifically approved for downstream installation. With a parallel flow arrangement, the dampers or other means used to control flow of air shall be adequate to prevent chilled air from entering the furnace, and if manually operated, must be equipped with means to prevent operation of either unit unless the damper is in full heat or cool position.

Flexible connections of nonflammable material may be used for return air and discharge connections to reduce the transmission of vibration. Though these units have been specifically designed for quiet, vibration free operation, air ducts can act as sounding boards and could, if poorly installed, amplify the slightest vibration to the annoyance level.

When the furnace is located in a utility room adjacent to the living area, the system should be carefully designed with returns which minimize noise transmission through the return air grille. Although these winter air conditioners are designed with large blowers operating at moderate speeds, any blower moving a high volume of air will produce audible noise which could be objectionable when the unit is located very close to a living area. It is often advisable to route the return air ducts under the floor or through the

Supply Duct Connections

Table 38. Supply duct connections

Furnace Orientation	Steps to be followed	Images for Reference
Upflow and Horizontal Furnace without Coil	Step 1., Step 12., Step 4., Step 5.	Figure 61, p. 59, Figure 62, p. 59
Upflow Furnace with Coil	Step 1., Step 2., Step 3., Step 4.	Figure 61, p. 59, Figure 63, p. 59, Figure 65, p. 59
Furnace in Horizontal Left with Coil	Step 1., Step 5., Step 3., Step 4.	Figure 61, p. 59, Figure 63, p. 59, Figure 67, p. 59

attic. Such design permits the installation of air return remote from the living area (i.e. central hall).

When the furnace is installed so that the supply ducts carry air circulated by the furnace to areas outside the space containing the furnace, the return air shall also be handled by a duct(s) sealed to the furnace and terminating outside the space containing the furnace.

For furnaces not equipped with a cooling coil, it is recommended that the outlet duct be provided with a removable access panel. The opening shall be accessible when the furnace is installed and shall be of such a size that the heat exchanger can be viewed for possible openings using light assistance or a probe can be inserted for sampling the air stream. The removable cover must be sealed to prevent air leaks.

Where there is no complete return duct system, the return connection must be run full size from the Furnace to a location outside the utility room, basement, attic, or crawl space.

Important: Do not install return air through the back of the Furnace cabinet. Do Not install return air through the side of the furnace cabinet on horizontal applications without following the guidelines in "Return Air Filters," p. 63 section of this document.

Carbon monoxide, fire or smoke can cause serious bodily injury, death, and/or property damage.

A variety of potential sources of carbon monoxide can be found in a building or dwelling such as gas-fired clothes dryers, gas cooking stoves, water heaters, furnaces and fireplaces. The U.S. Consumer Product Safety Commission recommends that users of gas-burning appliances install carbon monoxide detectors as well as fire and smoke detectors per the manufactures installation instructions to help alert dwelling occupants of the presence of fire, smoke or unsafe levels of carbon monoxide. These devices should be listed by Underwriters Laboratories, Inc. *Standards for Single and Multiple Station Carbon Monoxide Alarms, UL 2034* or CSA International Standard, *Residential Carbon Monoxide Alarming Devices, CSA 6.19*.

Notes:

- The manufacturer of your Furnace does not test any detectors and makes no representations regarding any brand or type of detector.
- Seal per local codes.

Table 38. Supply duct connections (continued)

Furnace Orientation	Steps to be followed	Images for Reference
Furnace in Horizontal Right with "A" Coil	Step 7., Step 8., Step 9., Step 6., Step 10., Step 4.	Figure 61, p. 59, Figure 62, p. 59, Figure 66, p. 59
Downflow Furnace with Coil	Step 7., Step 8., Step 9., Step 6., Step 10., Step 4.	Figure 61, p. 59, Figure 62, p. 59, Figure 68, p. 59
Downflow Furnace without Coil	Step 1., Step 12., Step 4., Step 5.	Figure 61, p. 59, Figure 63, p. 59

Figure 61. Initial position

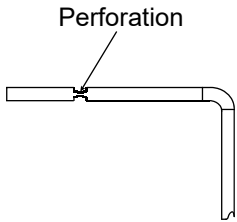

Figure 62. Flange orientation for upflow and horizontal left

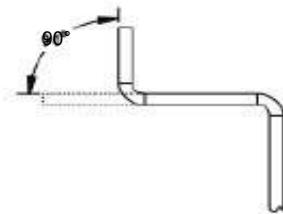

Figure 63. Flange orientation for downflow and horizontal right

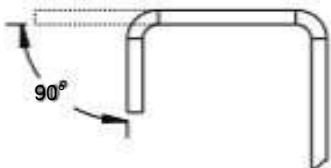

Figure 64. Perforated discharge duct flange

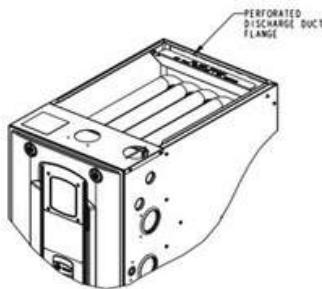

Figure 65. Upflow furnace with coil

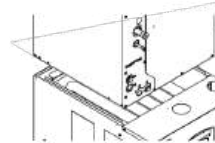

Figure 66. Horizontal left with or without coil

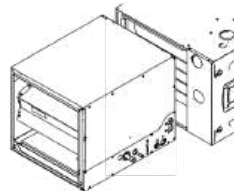

Figure 67. Horizontal right furnace with or without coil

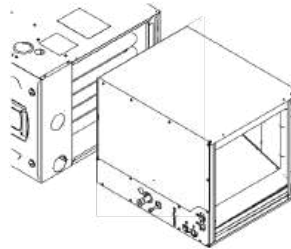
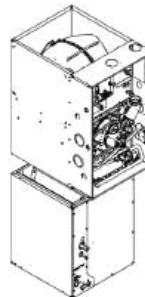

Figure 68. Downflow furnace with coil



Installation Steps

1. Bend furnace flanges up.
2. Set the coil on top of the furnace.
3. Screw through the coil cabinet into the furnace flange. Guide holes are located on the coil.
4. Seal per local codes and requirements.
5. Insulate the first 6–12 inches of the supply duct.
6. Support the furnace and coil independently.

Furnace General Installation

- Cut the back flange along perforation.
- Starting at the back of the furnace, cut the side flanges along perforations until past the end of the heat shield to avoid interference when bending.
- Bend furnace side flanges down.
- Match the coil up flush to the back of the furnace.
- Set the furnace on top of the coil so that it is flush with the back of the furnace.
- Attach ducting.

Return Duct Connections

Return Ducting General Guidelines

- Back returns are not allowed on any S-Series Furnaces
- Side returns are not allowed on downflow or horizontal S-Series Furnaces
- Mounting flanges must be located on ducting
- Shoot screws through the mount flanges into the furnace cabinet
- Always seal per local codes and requirements
- Furnace, coil, and ducting must be supported separately
- An external overflow drain pan must be installed in all applications over a finished ceiling to prevent property damage

Figure 69. Upflow furnace with bottom return in closet with remote filter

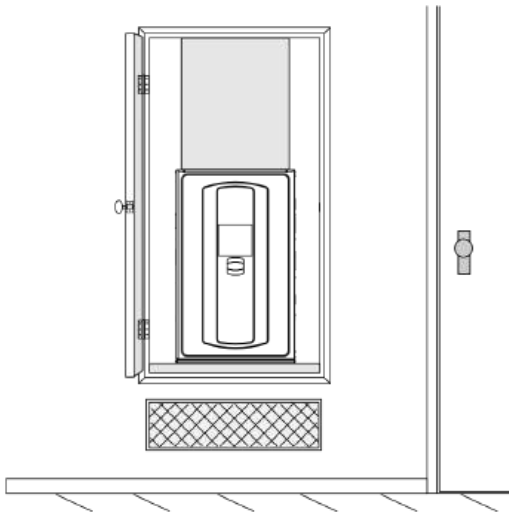

See [Step 1.](#), [Step 2.](#), [Step 3.](#), [Step 4.](#)

Figure 70. Upflow furnace with bottom return in closet with filter box

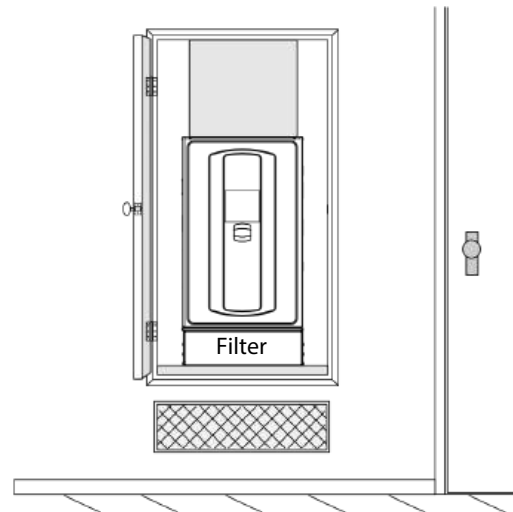

See [Step 1.](#), [Step 5.](#), [Step 6.](#), [Step 4.](#)

Figure 71. Upflow furnace with bottom return mounted on a ducted pedestal

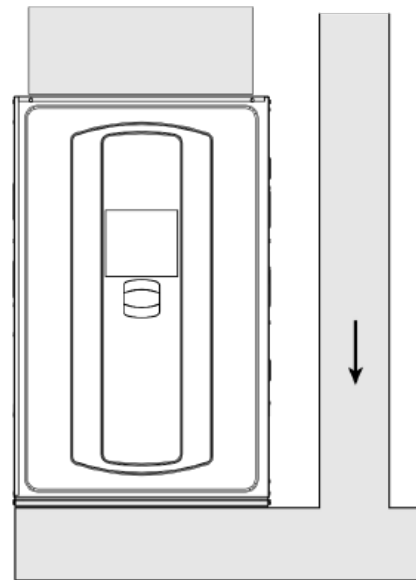

See [Step 1.](#), [Step 7.](#), [Step 8.](#), [Step 4.](#)

Figure 72. Upflow furnace with bottom return mounted on a ducted pedestal with filter box

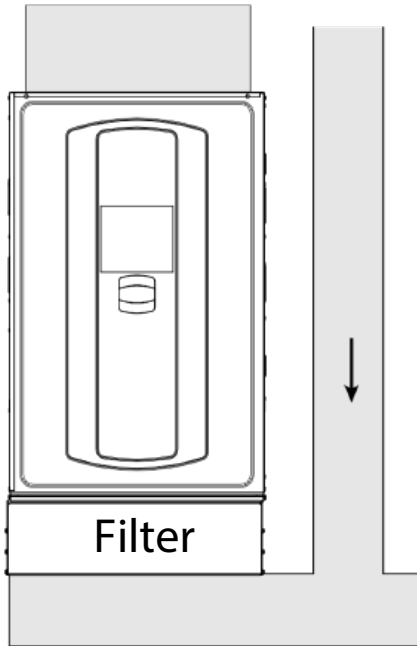

See Step 1., Step 9., Step 4.

Figure 73. Upflow furnace with bottom and side returns mounted on a ducted pedestal with side return and filter box

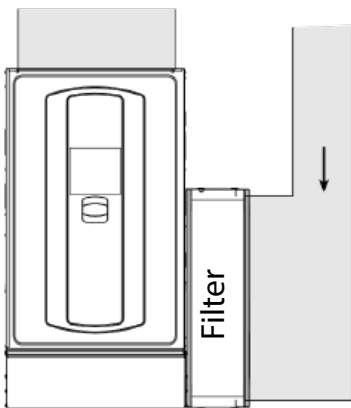

Important:

- Make sure the condensate and thermostat wiring holes are sealed on the cabinet side with the side return. The plugs and grommets may need to be changed with those on the opposite side of the cabinet..
- Make sure not to cut the cabinet in the "No Cut" area.

Notes:

- Use Optional BAYLIFT kit to lift furnace. Follow kit instructions.
- furnace bottom pedestal must be a minimum of 6-inch in height.

See Step 1., Step 10., Step 11., Step 12., Step 13., Step 14., Step 15., Step 4.

Figure 74. 17.5-inch filter cabinet with BAYLIFT kit

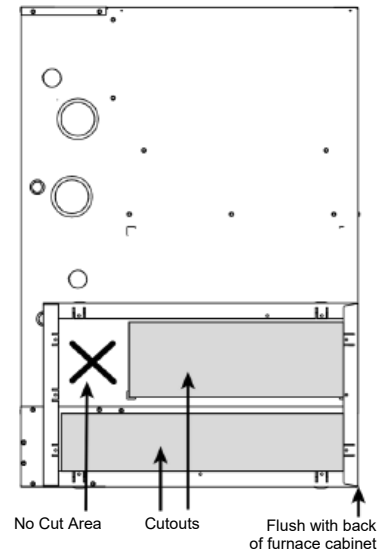
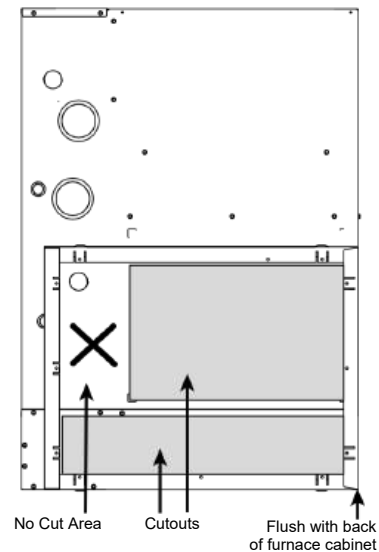
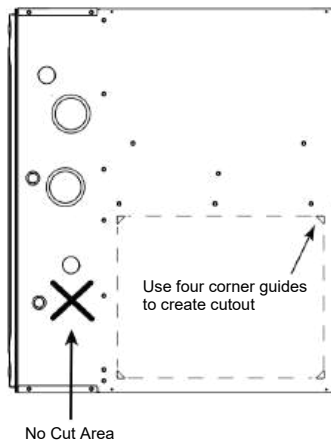

Figure 75. 21-inch filter cabinet with BAYLIFT kit



Furnace General Installation

Figure 76. Upflow furnace with side return



Important:

- Make sure the condensate and thermostat wiring holes are sealed on the cabinet side with the side return. The plugs and grommets may need to be changed with those on the opposite side of the cabinet.
- Make sure not to cut the cabinet in the “No Cut” area.

Notes:

- Return air on right side with the condensate on the left or return air on left with the condensate on the right do not require a transition.
- If using a filter box, use a transition, if possible, to attach the filter box to the furnace cabinet.

See [Step 16.](#), [Step 17.](#), [Step 18.](#), [Step 19.](#)

Figure 77. Upflow furnace with two side returns

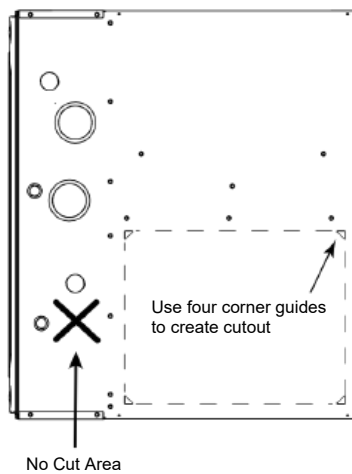

Important:

- One of the sides must have a transition to allow the condensate and thermostat wiring to exit the cabinet.
- If a transition is not a viable option, a hole may be drilled in the bottom of the cabinet to allow the condensate to exit. Also, a hole will need to be drilled in the side of the cabinet for the thermostat wiring to exit.
- Make sure not to cut the cabinet in the “No Cut” area.

Notes:

- If using one transition, the condensate and thermostat wiring will exit on the transition side.
- If using a filter boxes, use transitions, if possible, to attach the filter boxes to the furnace cabinet. If transitions are not used, condensate may exit through the bottom of the furnace.

See [Step 16.](#), [Step 17.](#), [Step 18.](#), [Step 19.](#)

Figure 78. Downflow furnace with top return

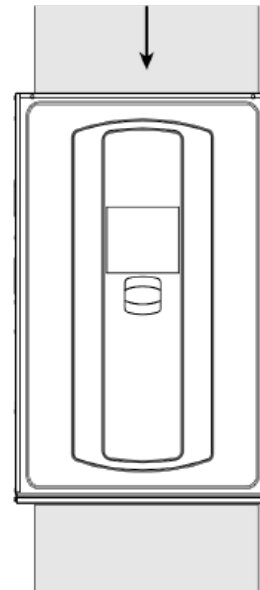

See [Step 20.](#), [Step 21.](#), [Step 3.](#), [Step 4.](#)

Figure 79. Downflow furnace with top return and plenum

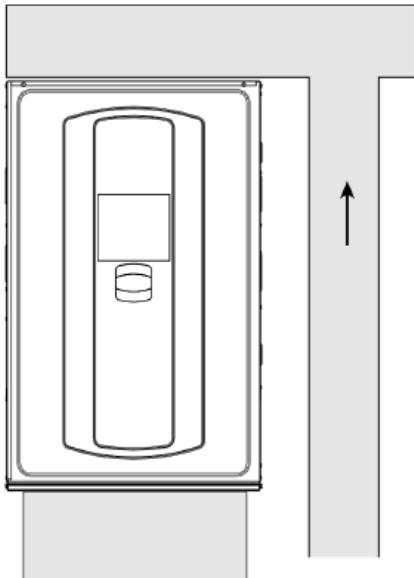

See Step 20., Step 22., Step 3., Step 4.

Figure 80. Downflow furnace with top return and plenum with filter box

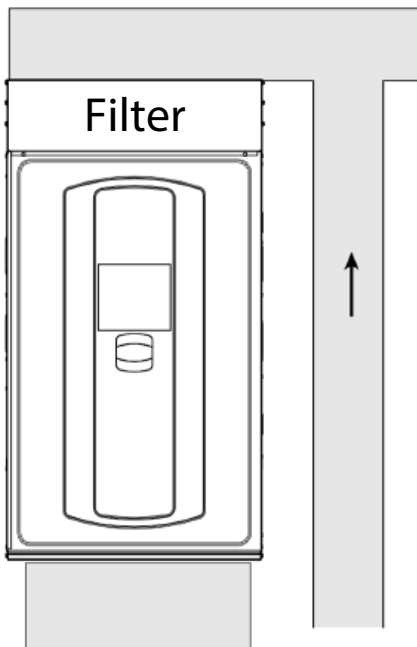

See Step 20., Step 23., Step 24., Step 4.

Installation Steps

1. Remove the bottom plate.
2. Set the furnace on the base inside closet.
3. Install remote filter.
4. Seal per local codes and requirements.
5. Set the furnace on the filter box inside closet.

6. Must have grill present for air.
7. Set the furnace on the ducted pedestal. The ducted pedestal will use ducted air from a remote location.
8. Install filter at a remote location.
9. Set the furnace on the filter box. The ducted pedestal will use ducted air from a remote location.
10. Create ducting and set the furnace in place.
11. Match the filter cabinet flush to the back and bottom sides of the furnace cabinet and secure in place with screws.
12. Mark the two areas to be cut out for the return air.
13. Cut out the two sections of the cabinet and BAYLIFT kit to be removed.
14. Attach ducting to the filter box.
15. The ducted pedestal will use ducted air from a remote location.
16. Using guides, remove the cutout for the side return.
17. Create ducting and set the furnace in place. Use screws to attach ducting to the furnace cabinet.
18. Seal bottom panel per local codes and requirements.
19. Seal all other panels per local codes and requirements.
20. Remove the top plate.
21. Attach the ducting to the top of the furnace.
22. Attach the plenum ducting to the top of the furnace.
23. Attach the filter box to the top of the furnace.
24. Attach ducting.

Return Air Filters

Typical Upflow Return Air Filter Installations

Filters are not factory supplied for upflow furnaces. Filter size needed will be dependent on type of filter and CFM requirement. Filters must be installed externally to the unit.

Important: It is recommended to transition return ducting to the same size as the opening. It is acceptable for return duct or filter frame to extend forward of the opening but plastic plugs **MUST** be installed in any opening that the duct or filter frame may cover.

Table 39. Upflow return air filters

Furnace Width (in.)	Filter Qty and Size(in.)
17-1/2	1-16x25x1 1-
21	20x25x1 1-
24-1/2	24x25x1

Note: For upflow furnace models in any configuration, where the airflow requirement exceeds 1600 CFM - Furnaces will require return air openings and filters on: (1) both sides, or (2) one side and the bottom, or (3) just on the bottom.

Furnace General Installation

Preparation for Upflow Bottom and Side Return Air Filter Installations

All return air duct systems should provide for installation of return air filters.

1. Determine the appropriate position to set the furnace in order to connect to existing supply and return ductwork.
2. For upflow side return installations, remove the insulation around the opening in the blower compartment
3. The side panel of the upflow furnace includes locating notches that are used as guides for cutting an opening for return air, refer to the figure and the upflow furnace outline drawing for duct connection dimensions for various furnaces.
4. If a 3/4-inch flange is to be used for attaching the air inlet duct, add to cut where indicated by dotted lines. Cut corners diagonally and bend outward to form flange.
5. If flanges are not required, and a filter frame is installed, cut between locating notches as in illustration.
6. The bottom panel of the upflow furnace must be removed for bottom return air.

Figure 81. Upflow furnaces only

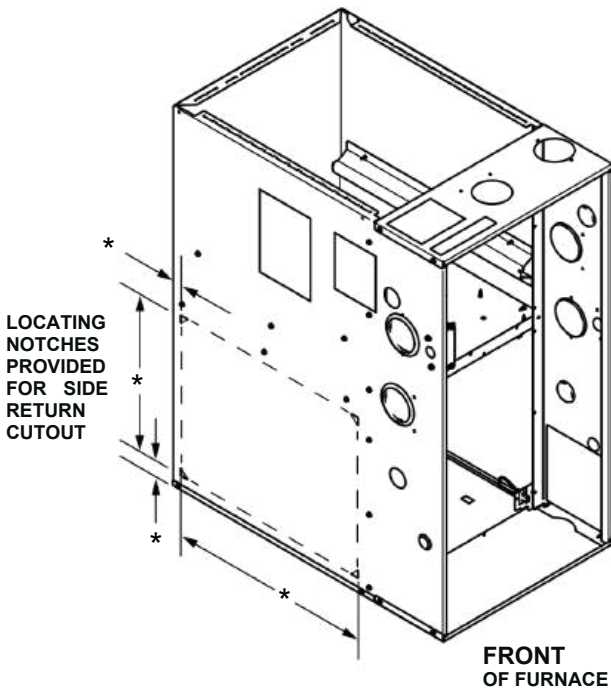

Note: See dimensional data drawing.

Return Air Filters for Furnace in Horizontal Configuration When the furnace is installed in the horizontal configuration, the return air filters must be installed exterior to the furnace cabinet. Remote filter grilles may be used for homeowner convenience, refer to [Figure 82, p. 64](#) or the

filters may be installed in the duct work upstream of the furnace, refer to [Figure 83, p. 64](#).

Filter kits are available for horizontal applications.

Note: Direct coupled side returns are not allowed to the furnace cabinet.

Figure 82. Remote filter installation

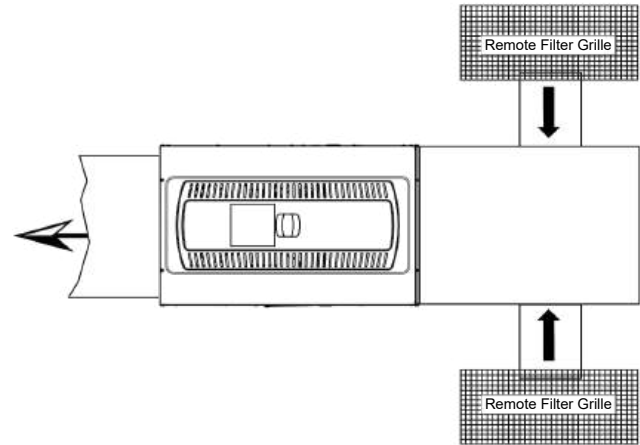
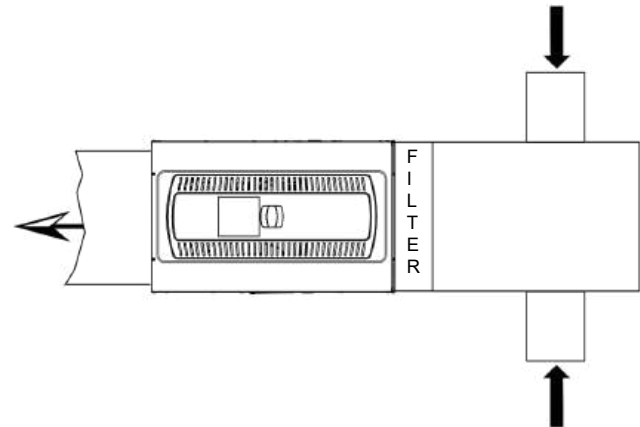

Figure 83. Duct filter installation



Typical Downflow Furnace Return Air Filter Installations

Filters are not factory supplied for downflow furnaces. Filter size needed will be dependent on type of filter and CFM requirement. Filters must be installed externally to the unit.

Table 40. Downflow return air filters

Furnace Width (in.)	Filter Qty and Size (in.)
17-1/2	1-16x25x1
21	1-20x25x1
24-1/2	1-24x25x1

Electrical Connections

Make wiring connections to the unit as indicated on enclosed wiring diagram. As with all gas appliances using

electrical power, this furnace shall be connected into a permanently live electric circuit. It is recommended that furnace be provided with a separate "circuit protection device" electric circuit. The furnace must be electrically grounded in accordance with local codes or in the absence of local codes with the National Electrical Code, ANSI/NFPA 70, if an external electrical source is utilized. *The*

Field Wiring

Figure 84. S9B1/S9X1 with one or two stage AC or HP

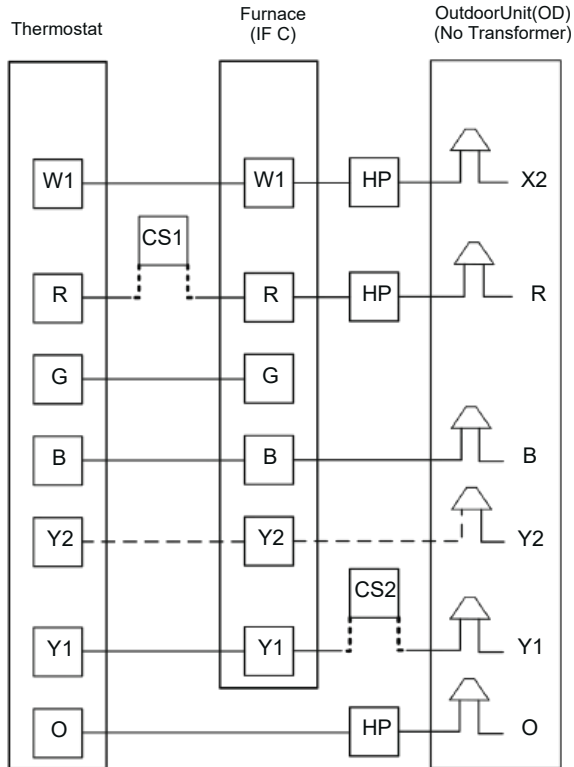

integrated furnace control is polarity sensitive. The hot leg of the 120V power supply must be connected to the black power lead as indicated on the wiring diagram.

See the "Wiring Diagrams," p. 26 section in this document and unit wiring diagram attached to furnace.

Notes:

- 1) HP = Wiring used for Heat Pump System.
- 2) CS = wiring used for Condensate Switch (2 Options).
- 3) Y1 and/or Y2 must be connected from the thermostat to the IFC for proper airflow.
- 4) A/TCONT824 thermostats do not require the use of X2.
- 5) Recommended 1 st stage airflow is 75% of total airflow.
- 6) Y2 and EAC/HUM terminals not available on S9B1.

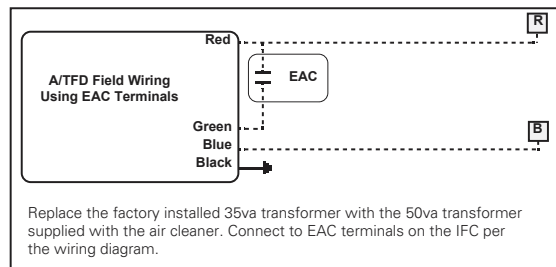

Furnace General Installation

Figure 85. S9X2 with one or two stage AC or HP

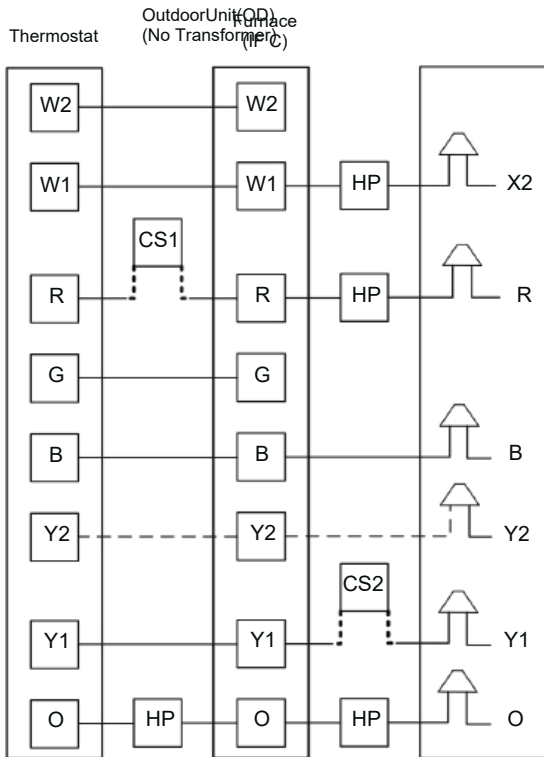

Notes:

- 1) HP = Wiring used for Heat Pump System.
- 2) CS = wiring used for Condensate Switch (2 Options).
- 3) Y1 and/or Y2 must be connected from the thermostat to the IFC for proper airflow.
- 4) Remove Y1-O jumper for HP systems. O terminal must be connected as shown for gas heating operation during defrost.
- 5) If the thermostat does not have a W2, or there are not enough conductors, jumper W1 to W2 at the IFC.
- 6) A/TCONT824 thermostats do not require the use of X2.
- 7) Recommended 1 st stage airflow is 75% of total airflow.

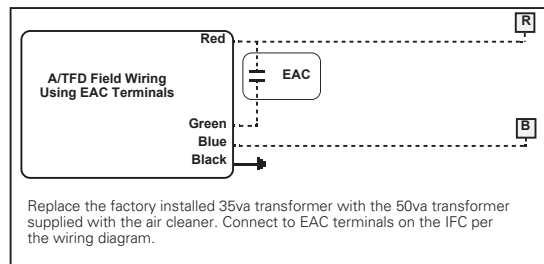
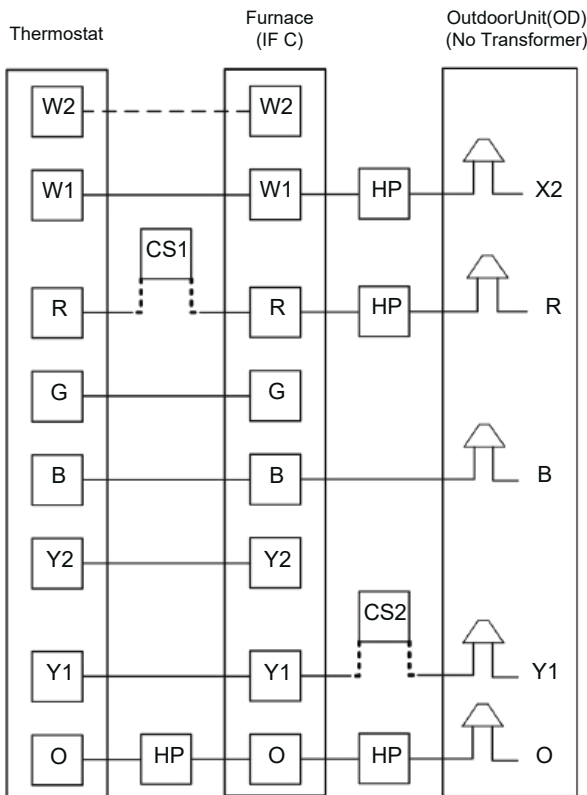
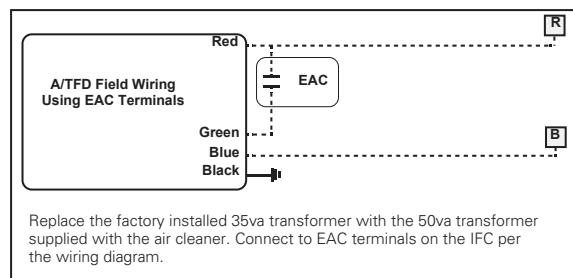

Figure 86. S9B1, S9X1/S9X2 with single stage AC or HP with two stage airflow



Notes:

- 1) HP = Wiring used for Heat Pump System.
- 2) CS = wiring used for Condensate Switch (2 Options).
- 3) Y1 and Y2 must be connected from the thermostat to the IFC for proper airflow.
- 4) Thermostat must be setup for 2 stage OD.
- 5) IFC Must be setup for 2 stage OD using the Menu/Option Buttons.
- 6) For S9X2, remove Y1-O jumper for HP systems. O terminal must be connected as shown for gas heating operation during defrost.
- 7) Recommended 1 st stage airflow is 75% of total airflow.
- 8) A/TCONT824 thermostats do not require the use of X2.
- 9) W2 and O not available for S9B1 or S9X1.
- 10) EAC/HUM terminals not available on S9B1.



Twinning

Figure87. Twinningconnectiondiagramfortwinnings-seriesfurnaces2stageheater1stagecoolingthermostatfor non-A2L systems

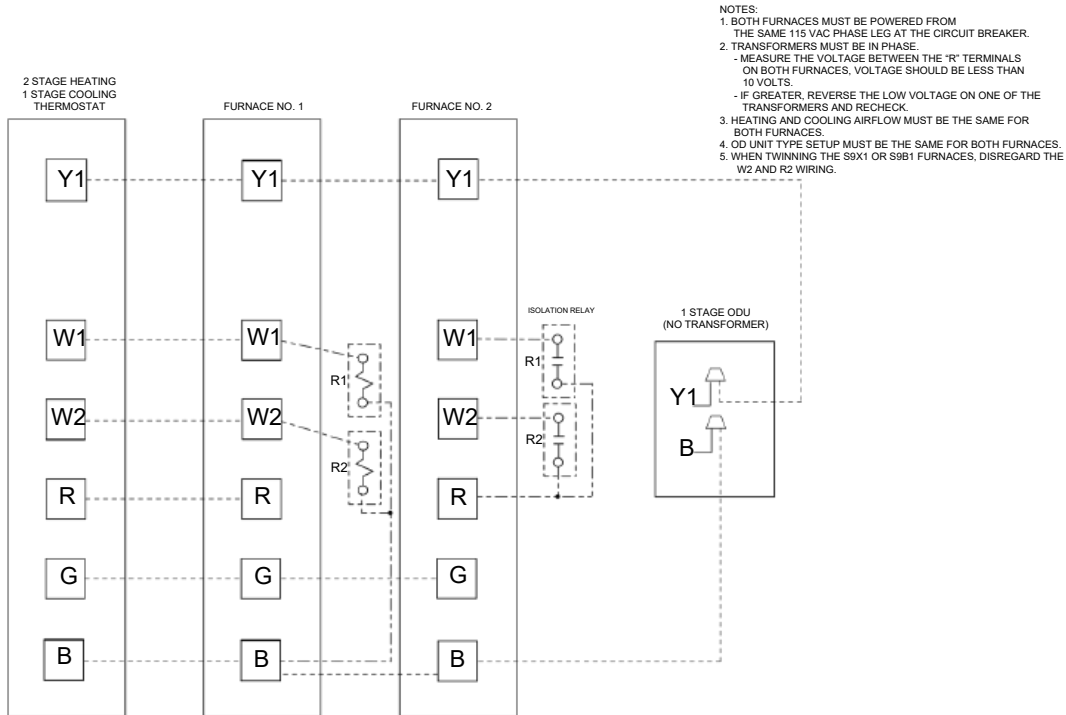
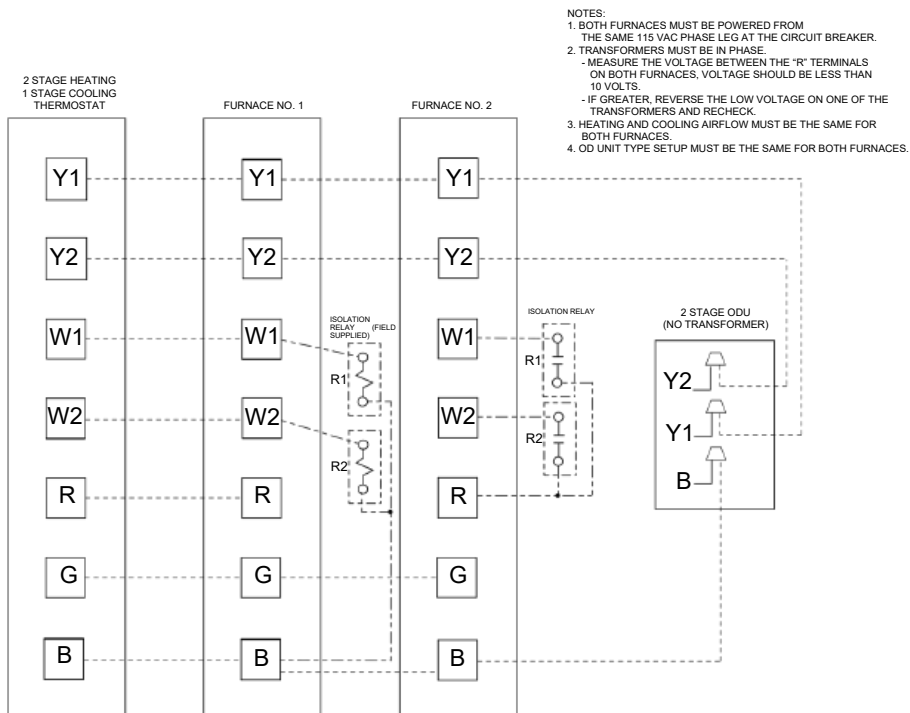

Figure88. Twinningconnectiondiagramfortwinnings-seriesfurnaces2stageheater2stagecoolingthermostatfor non-A2L systems



Furnace General Installation

Figure89. Twinningconnectiondiagramfortwinnings-seriesfurnaces2stageheater1stagecooling(with transformer) thermostat for non-A2L systems

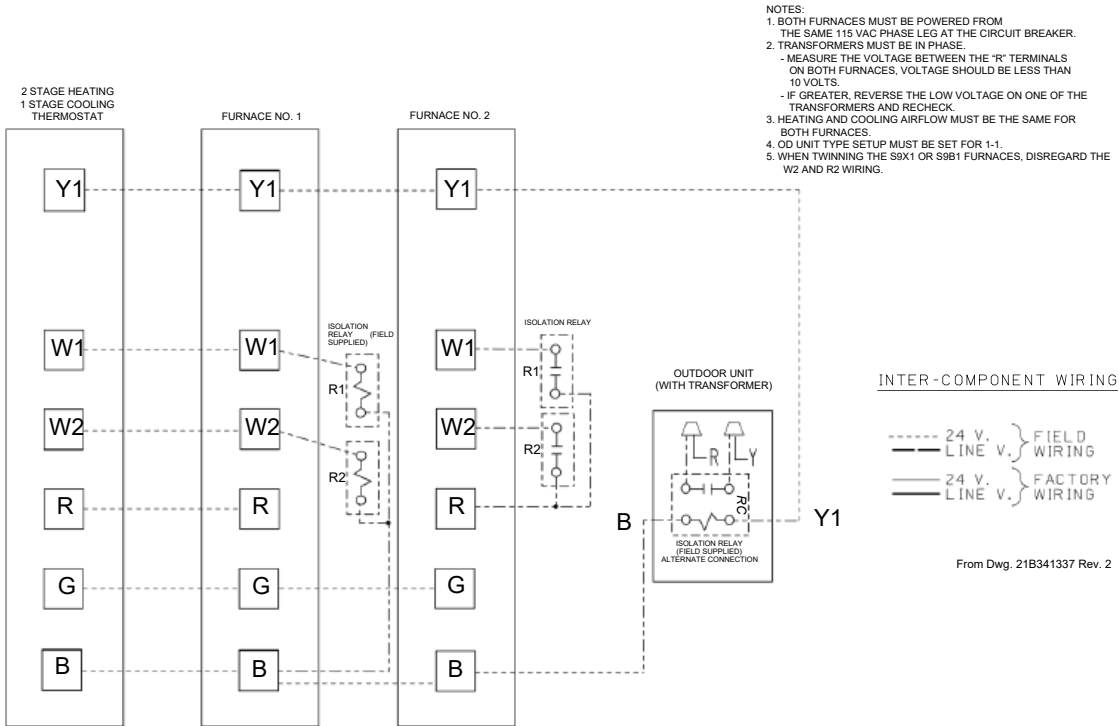
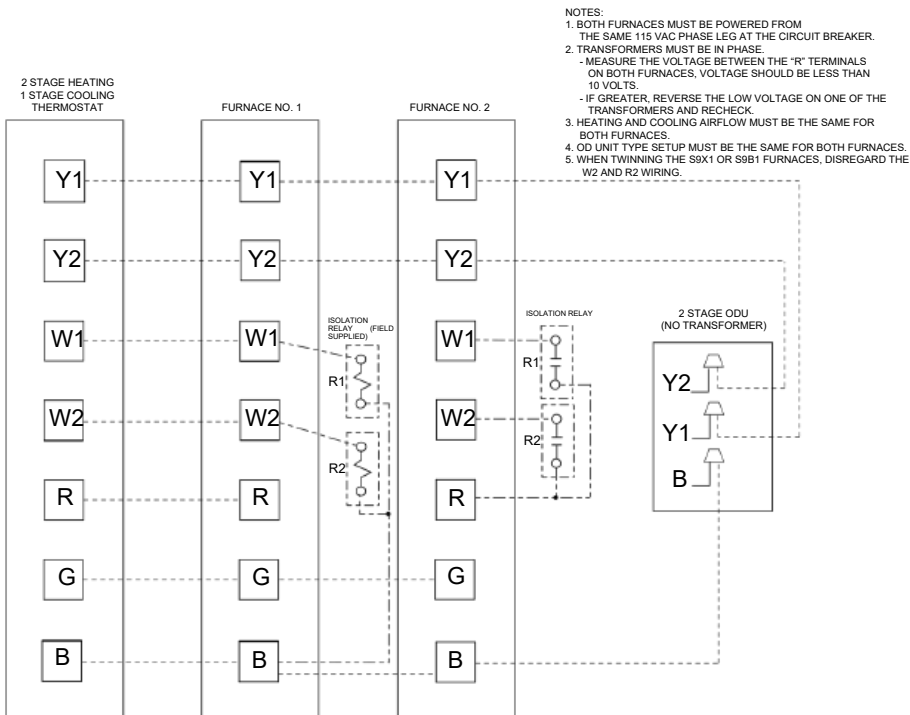

Figure90. Twinningconnectiondiagramfortwinnings-seriesfurnaces2stageheater2stagecoolingthermostatfor non-A2L systems



Condensate Drain Instructions

The following sections give general instructions for the installation of the gas furnace condensate drains. Repositioning of the condensate trap is covered in the exhaust air options section.

Cutouts with plugs and grommets are provided on the left and right hand side of the furnace cabinets for drain connections in vertical applications. The standard arrangement is for the drain connection on the left side. The tubing may have to be trimmed in this application to avoid kinking.

The upflow (vertical application) also has provisions for right side drain connections. Exchange the grommet and plugs from the left and right side. Trim all excess tubing to avoid kinking.

It is always recommended that an auxiliary drain pan be installed under a horizontally installed evaporator or 90% Gas Furnace. Connect the auxiliary drain line to a separate drain line (no trap is needed in this line).

Horizontal applications require repositioning the condensate canister trap. Additionally the drain tubing connected to the inducer housing may need to be repositioned for removing the plug and reconnecting the tubing to the lower connection on the inducer housing.

Connections must be made to an open/vented drain.

Notes:

- All condensate drain piping supplies included with the furnace are intended for internal piping only and should not be applied external to the furnace. All external piping must use 1/2-inch minimum size PVC pipe and fittings throughout for drain connections (fittings, pipe and PVC solvent cement not provided with furnace, must be field supplied). A 3/4-inch coupling is supplied to connect to systems that are using 3/4-inch piping with an air conditioner coil.
- A corrosion resistant condensate pump must be used if a pump is required for a specific drain system.

⚠ CAUTION

Water Damage!

Failure to follow instructions below could result in minor to moderate injury or equipment damage. Install a drain pan under the furnace to prevent leaking condensate.

Figure 91. Condensate management



Important: The condensate drain should be installed with provisions to prevent winter freeze-up of the condensate drain line. Frozen condensate will block drains, resulting in furnace shutdown. If the drain line cannot be installed in a conditioned space and/ or its surrounding ambient temperature is expected to fall below freezing, then heat tape should be applied as required to prevent freezing (per manufacturer's instructions). The heat tape should be rated at 5 or 6 watts per foot at 120 Volts. Self-regulating (preferred) or thermostatically controlled heat tape is required.

Typical sources of UL listed heat tapes are W.W. Granger, Inc. (Wintergard Plus™ Series), McMaster Carr Supply Co. (3554 Series), or your equipment supplier.

The condensate drain may be cleaned or inspected by removal of the drain tube at the header.

Evaporator and Furnace condensate drain piping may be manifolded together. A primary drain vent stack must be installed and terminated below the outlet of the secondary heat exchanger drain connection to prevent water from damaging Furnace controls if the primary drain outlet plugs up.

Where the Furnace is installed above a finished ceiling, the primary drain vent stack must be installed such that overflow from the vent stack opening will flow into an auxiliary drain pan in order to prevent water damage to the finished ceiling below.

Vertical Applications

Upflow Furnace

1. Remove the plug from the side panel where the condensate will exit.
2. Install the condensate grommet into the side panel.
3. Install the connection tubing from the trap to the side of the unit and trim all excess tubing to avoid kinks.

Note: For easiest installation, remove the spring clip from the end of the condensate line and feed through the grommet.

Important: Condensate grommet must be installed for proper operation.

Condensate Drain Instructions

Figure 92. Left side drain

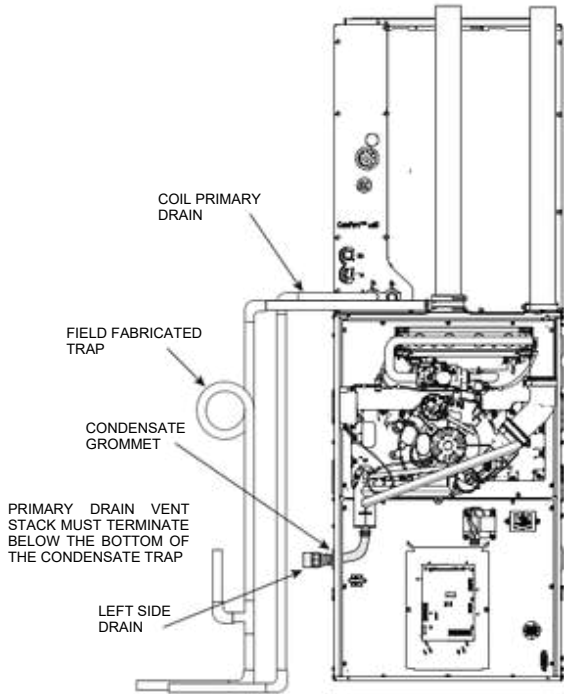

Figure 94. Right side drain

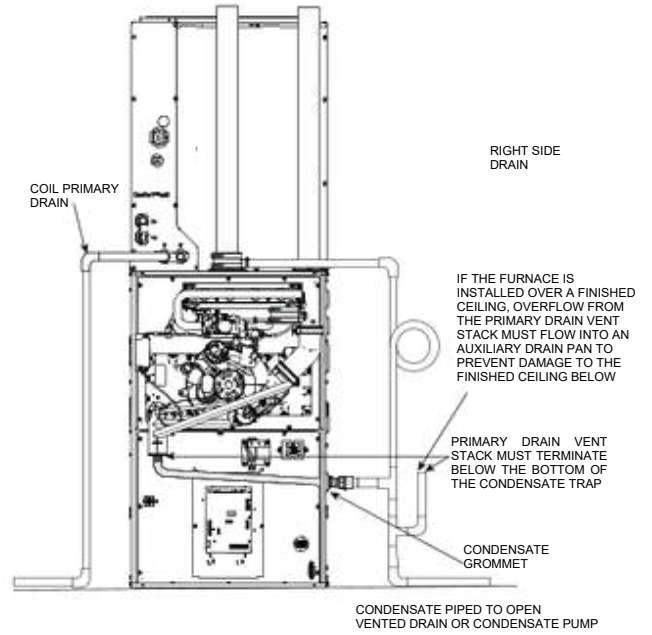

Figure 93. Right side drain

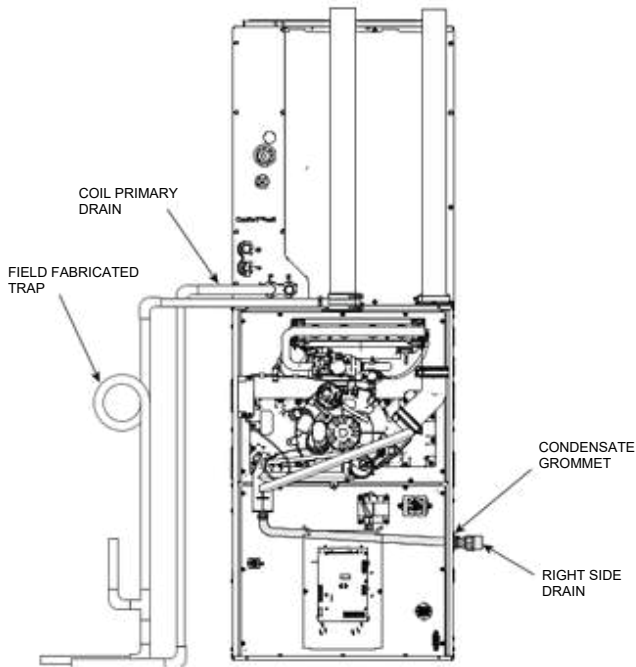

Figure 95. Left side drain

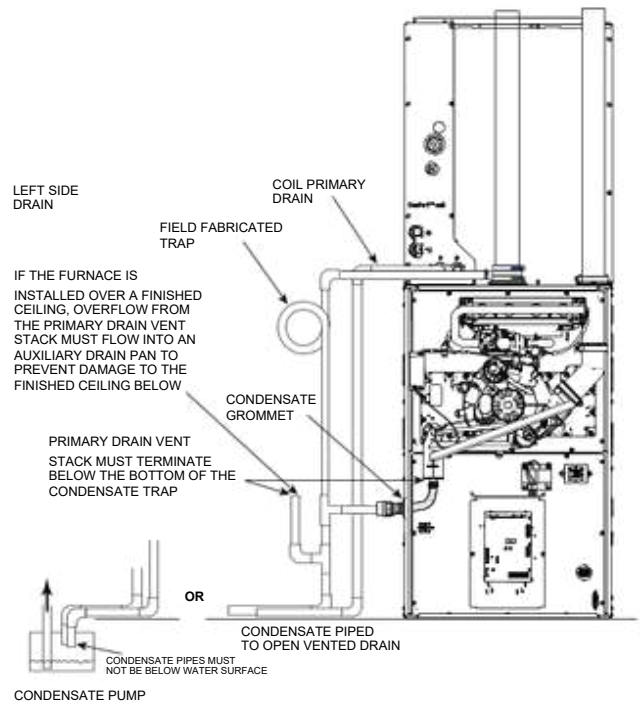
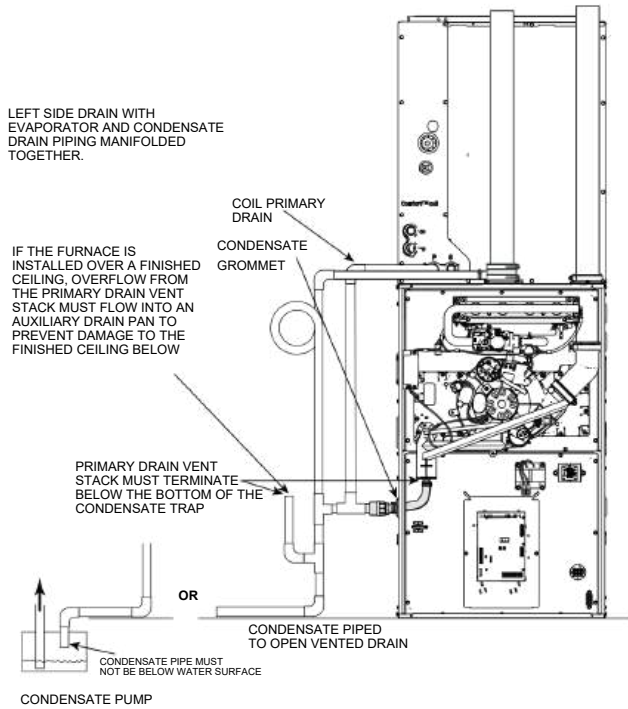

Figure 96. Left side drain with evaporator and condensate drain piping manifolded together



Downflow Furnace

1. Cut the 90 degree section of the condensate tubing off and connect the tubing to the condensate trap.
2. Install the condensate grommet into the bottom panel.
3. Cut to length as needed.

Figure 97. Downflow furnaces with bottom drain

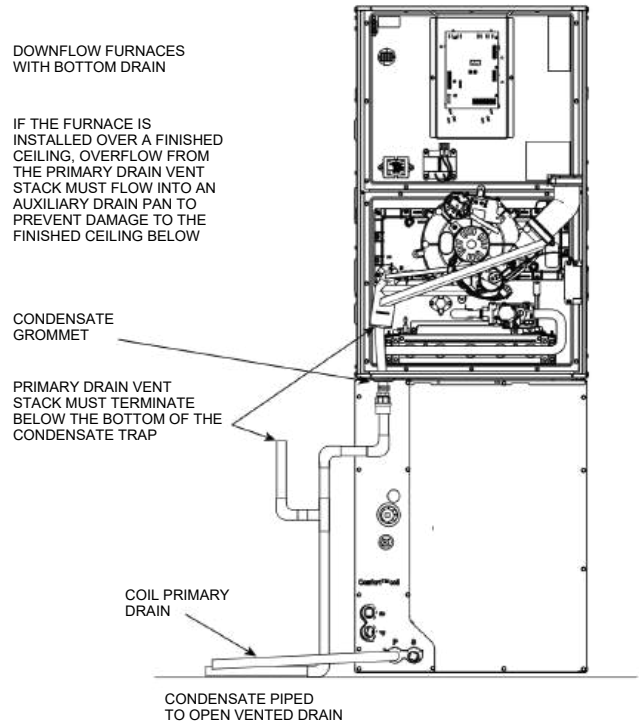

Downflow Furnace with Left Side Condensate

1. Remove left hand condensate plug.
2. Install into bottom cross member.

Figure 98. Downflow furnace with left side condensate

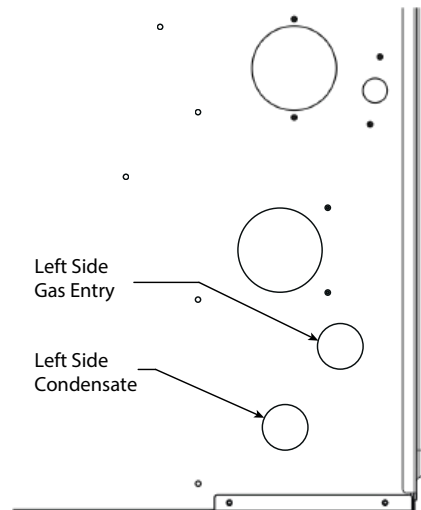

3. Plug the bottom hole with plug provided in document pack.

Condensate Drain Instructions

Figure 99. Plug the bottom hole with plug provided in document pack

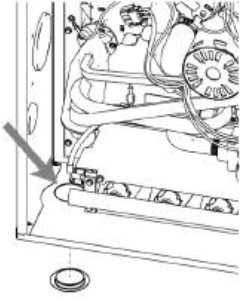

Attaching the condensate drain line

1. Locate the condensate grommet and the condensate drain line assembly in the doc pack.
2. Insert the condensate grommet in the 1-5/8-inch hole in the side of the cabinet.
3. Remove the fitting at the end of the drain line assembly and insert it through the cabinet from the inside out. Attach the 90 degree section of the hose to the condensate drain trap.
4. Cut off the excess tube and reinstall the end fitting to the drain hose.

Figure 100. Downflow furnaces with left side drain

BOTTOM HOLE MUST BE PLUGGED.

IF THE FURNACE IS INSTALLED OVER A FINISHED CEILING, OVERFLOW FROM THE PRIMARY DRAIN VENT STACK MUST FLOW INTO AN AUXILIARY DRAIN PAN TO PREVENT DAMAGE TO THE FINISHED CEILING BELOW

CONDENSATE GROMMET

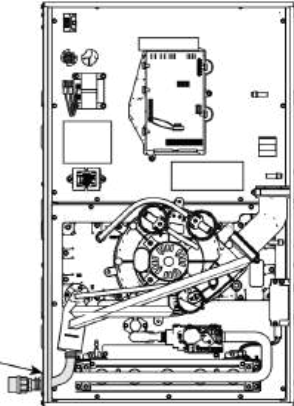

Downflow Furnace with Right Side Condensate

1. Drill an 11/16-inch diameter hole in the right side of the case at the dimensions shown.
2. Plug the bottom hole with plug provided in the bottom pack. Refer .

Figure 101. Downflow furnace with right side condensate

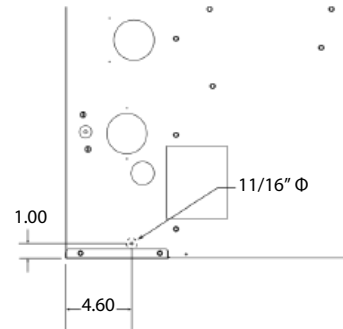

Attaching the condensate drain line

1. Locate the condensate drain line assembly in the doc pack.

Important: It is best to cut the condensate drain hose assembly longer than 4 inches and then fit in place. It can then be trimmed to needed length. The 4-inch measurement is an approximation.

2. Cut the condensate drain line assembly as shown.
3. Use a field supplied hose clamp to secure the condensate drain line to the condensate trap.
4. Insert a field supplied piece of 1/2-inch CPVC pipe through the 11/16-inch hole drilled through the cabinet and insert into drain line hose. Secure with the spring clip.

Note: Seal around the condensate drain tubing where it exits the cabinet.

Figure 102. Downflow furnaces with right side drain

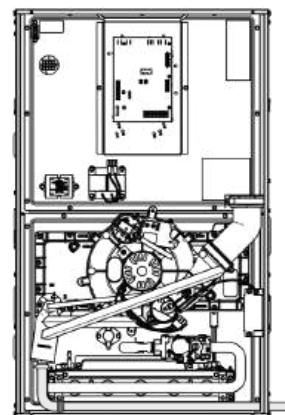
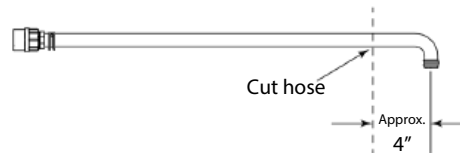

11/16" DIAMETER HOLE MUST BE CUT IN RIGHT SIDE OF CASE. BOTTOM HOLE MUST BE PLUGGED. CUT FACTORY SUPPLIED CONDENSATE ASSEMBLY HOSE AND ATTACH TO FIELD SUPPLIED CPVC TUBE. SECURE WITH SPRING CLIP AND FIELD SUPPLIED HOSE CLAMP.

IF THE FURNACE IS INSTALLED OVER A FINISHED CEILING, OVERFLOW FROM THE PRIMARY DRAIN VENT STACK MUST FLOW INTO AN AUXILIARY DRAIN PAN TO PREVENT DAMAGE TO THE FINISHED CEILING BELOW

Horizontal Applications

Upflow Models in Horizontal

It is always recommended that the auxiliary drain pan be installed under a horizontally installed evaporator and/or 90% gas furnace. Connect the auxiliary drain pan to a separate drain line (no trap is needed in this line).

Connections must be made to an open/vented drain. Outdoor draining of the furnace and coil condensate is permissible if allowed by local codes. Caution should be taken to prevent drains from freezing or causing slippery conditions that could lead to personal injury. Excessive draining of condensate may cause saturated ground conditions that may result in damage to plants.

Notes:

- Use 1/2-inch or larger PVC or CPVC pipe and fittings as required for drain connections (fittings, pipe and solvent cement not provided).
- A corrosion resistant condensate pump must be used if a pump is required for a specific drain system.

Important: The condensate drain should be installed with provisions to prevent winter freeze-up of the condensate drain line. Frozen condensate will block drains, resulting in furnace shutdown. If the drain line cannot be installed in a conditioned space, then UL listed heat tape should be applied as required to prevent freezing (per manufacturer's instructions). The heat tape should be rated at 5 or 6 watts per foot at 120 volts. Self-regulating (preferred) or thermostatically controlled heat tape is required.

Figure 103. Horizontal applications

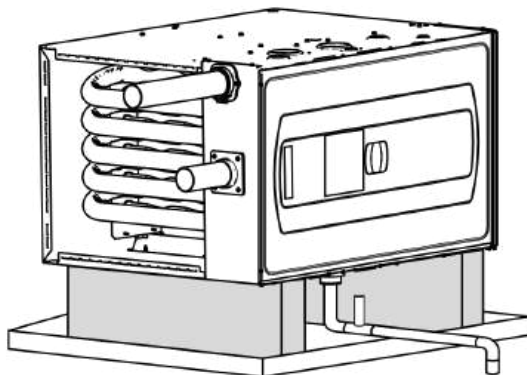

FURNACE MUST BE SUPPORTED AT ALL FOUR CORNERS. BAYHANG - OPTIONAL HORIZONTAL HANGING BRACKET KIT TO APPROVED OPEN / VENTED DRAIN

Note: The overflow stand pipe termination must be even with or slightly below the bottom of the condensate trap.
 Note: Water from the overflow pipe must drain into the emergency drain pan.

To prevent AC condensate from backing up into the furnaces, follow these instructions for condensate drainage.

1. The overflow stand pipe termination must be even with or slightly below than the bottom of the condensate trap.
2. Water from the overflow pipe must drain into the emergency drain pan.
3. It is recommended to use these secondary drain. The secondary drain pipe must terminate over the emergency drain pan.
4. Emergency drain pan.

NOTICE

Equipment Damage!

Failure to follow instructions below could result in intermittent or improper operation, or equipment damage.

A blocked main drain with an overflow standpipe that is higher than the bottom of the condensate trap can result in an E09 Condensate Pressure Switch Trip error. Additionally, a condensate pressure switch hose that is not trimmed to fit can also cause this error. In extreme cases, these issues can lead to an E04 Rollout Thermal Limit Trip error.

An overflow standpipe with an opening even with or slightly below the bottom of the condensate trap must be installed. The condensate pressure switch hose must be trimmed to fit.

Figure 104. Horizontal right

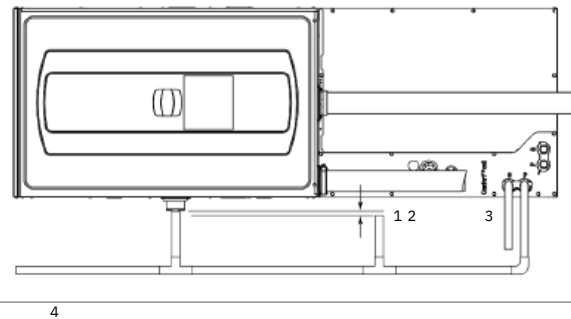
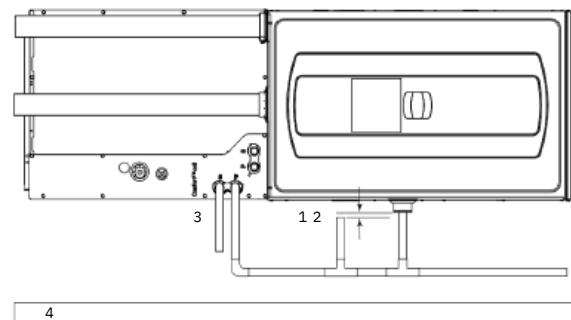

Figure 105. Horizontal left



General Start-Up and Adjustment

The following sections provide instructions for the general start-up and adjustment of the gas furnaces.

Preliminary Inspections

With gas and electrical power "OFF", confirm:

1. Duct connections are properly sealed.
2. Filters are in place.
3. Venting is properly assembled.
4. Blower vestibule panel and all screws are in place.

Turn knob on main gas valve within the unit to "OFF". Turn the external gas valve to "ON". Purge the air from the gas lines. After purging, check all gas connections for leaks with a soapy solution.

Do not check with an open flame allow 5 minutes for any gas that might have escaped to dissipate. Turn the gas valve in the unit to the "ON" position.

Propane Gas being heavier than air may require forced ventilation. Turn the toggle switch on the Gas Valve in the unit to the "ON" position.

Lighting Instructions

Lighting instructions appear on each unit. Each installation must be checked out at the time of initial start up to ensure proper operation of all components. Check out should include putting the unit through one complete cycle as outlined below.

Turn on the main electrical supply and set the comfort control above the indicated temperature. The igniter will automatically heat and the gas valve is energized to permit the flow of gas to the burners. After ignition and flame is established, the flame control module monitors the flame and supplies power to the gas valve until the comfort control is satisfied.

⚠ WARNING

Risk of Fire or Explosion!

Failure to follow instruction below could result in death or serious injury or property damage.

Do NOT attempt to manually light the furnace.

To shut off

For complete shutdown, turn the toggle or control switch located on the main gas valve inside the unit to OFF and the external main gas shutoff valve to OFF. Disconnect the electrical supply to the unit.

Inspect temperature in a vacant house especially during freezing weather. If for any reason your furnace should fail to operate damage could result, such as frozen water pipes.

⚠ CAUTION

Freeze Damage!

Failure to follow instructions below could result in minor to moderate injury or property damage.

Insulate vent pipes with 1/2 inch (12.7 mm) Armaflex-type insulation or equivalent when passing through unheated spaces exposed to freezing temperatures. Insulation is not needed if the space is heated enough to prevent freezing. If domestic water pipes are not protected from freezing, the space is considered heated. Schedule qualified personnel to inspect the temperature if the house is vacant during freezing weather. A furnace failure could lead to frozen water pipes.

Control and Safety Switch Adjustment

Limit Switch Check Out

The limit switch is a safety device designed to close the gas valve should the furnace become overheated. Since proper operation of this switch is important to the safety of the unit, it must be checked out on initial start up by the installer.

To check for proper operation of the limit switches, set the thermostat to a temperature higher than the indicated temperature to bring on the gas valve. Restrict the airflow by blocking the return air to the blower. When the furnace reaches the maximum outlet temperature as shown on the rating plate, the burners must shut off. If they do not shut off after a reasonable time and overheating is evident, a faulty limit switch is probable and the limit switch must be replaced. After checking the operation of the limit control, be sure to remove the paper or cardboard from the return air inlet, or reconnect the blower.

Furnace Combustion Air Exhaust Options

Important:

- All plugs must be in place for sealed combustion.
- If the locations are changed from the defaults, the default holes not being used must be plugged.
- The combustion air exhaust must be vented to the outdoors.

Notes:

- Default is left side for electric and natural gas connections. Default for the combustion air inlet and exhaust is top of the furnace.
- If the electrical and natural gas connections are moved to the right side, remove the plugs and move them to the left side. The grommets will move from the left side to the right side.
- The grommets are different for the natural gas and condensate connections.
- The combustion air inlet does not have to be on the same side as the combustion air exhaust.

Refer to the illustrations below to find the approved venting options for upflow and horizontal left furnace applications.

Note: Choose any combination such that it must have one inlet and one outlet.

Figure 106. Upflow application

Combustion air exhaust vented out at the top.

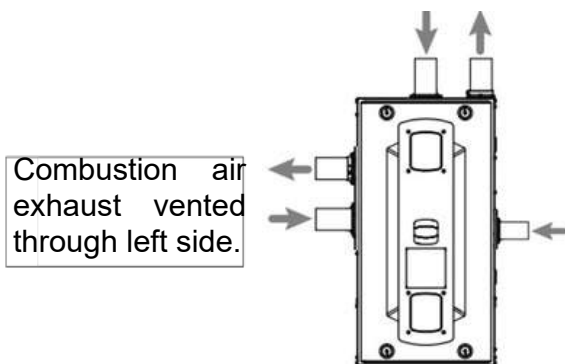

Figure 107. Horizontal left application

Combustion air exhaust vented out at the top.

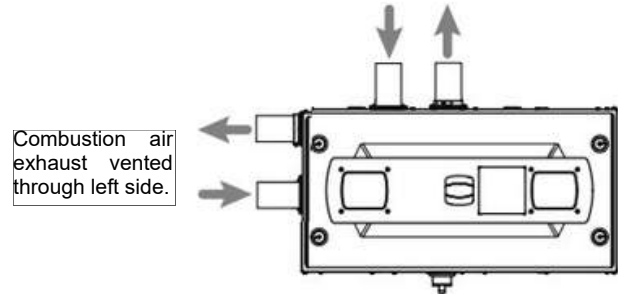

Figure 108. Horizontal right application

Combustion air exhaust vented out at the top.

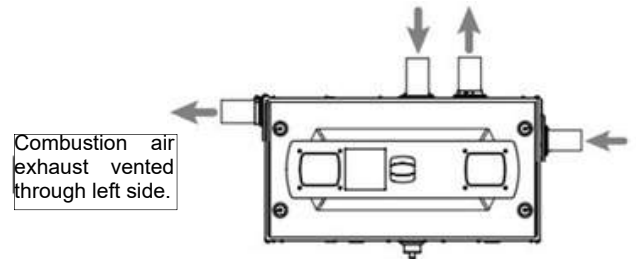
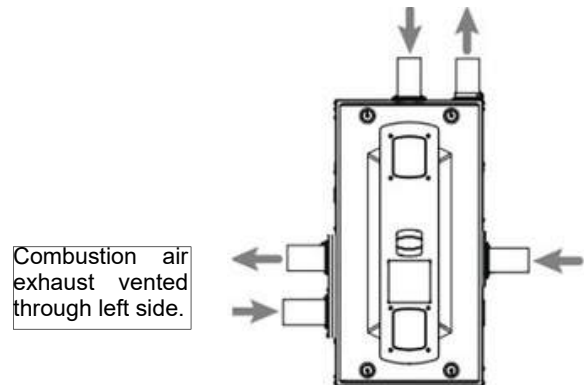

Figure 109. Downflow application

Combustion air exhaust vented out at the top.



Factory Set Up - Upflow and Downflow Orientation

Figure110. Upflow, horizontal left, and horizontal right orientations

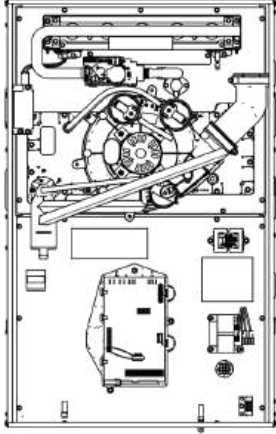

Figure111. Downflow orientation

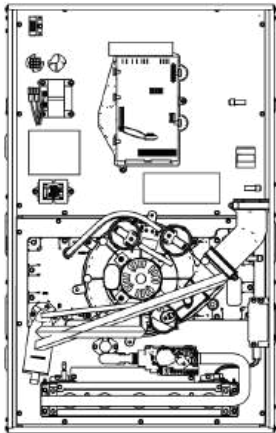

Figure112. Grommet trap for horizontal left and right application



Figure113. Conversion instructions



Conversion Instructions

Upflow Furnace in Upflow Position - Top Vented Combustion Air

Important:

- Trim the condensate pressure switch tubing to length to ensure there is no sag or trap created.
- Refer to the image at the initial part of this section to see the furnace as seen from the factory.

1. Attach the vent outlet gasket to the vent outlet.
2. Install vent outlet to top of cabinet using two screws supplied in the doc pack.
3. Install vent inlet gasket and vent inlet using four screws supplied in the doc pack.

Figure114. Vent inlet/outlet

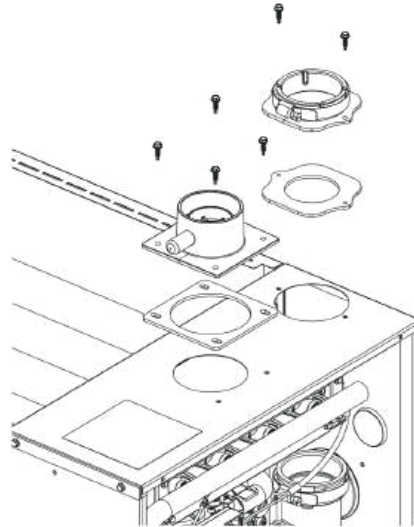

4. Slide PVC pipe through vent outlet adaptor and insert into inducer outlet.
5. Twist to ensure PVC is fully inserted.
6. Tighten the clamp on the end of the 45° elbow.
7. Tighten the clamp on the outlet vent adapter.

Note: The vent outlet adapter is used for strain relief against the weight of the venting. The clamp should be tightened after the internal connection is made.

8. Install the combustion air inlet PVC pipe.

Note: If required, transition to larger venting within 2-inch of the cabinet. CPL00938 – 2-inch x 3-inch offset coupling may be used and is factory supplied with 120 KBTUH furnaces. Canadian applications may use BAYREDUCE to meet ULC-S636 requirements.

Figure115. Upflow furnace in upflow position

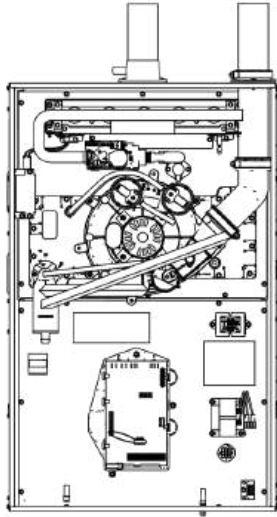
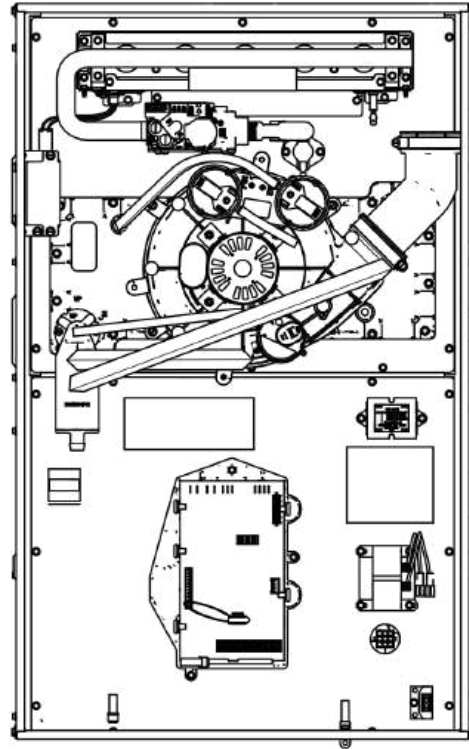

Figure116. Upflowposition-leftsidevented combustion air



Upflow Position - Left Side Vented Combustion Air

Changes need to be made to the inducer orientation when installing the upflow furnace with the combustion air vented through the side. Additional changes are needed for hose routing and PS2 rotation.

The figure to the top left in next page shows the furnace as it is sent from the factory.

Use the following steps to modify the furnace for upflow with side venting of combustion air.

Important:

- *Right side vent outlet is not allowed because condensate will not drain.*
- *PS2 conversion does not apply to the S9X1 or S9B1 models.*

Before proceeding, lay unit on its back to make conversion easier.

1. Disconnect all drain tubes from condensate trap.

Note: *When removing condensate hoses from the condensate trap, hold the trap with your hand to prevent the trap from breaking. Removing the trap before the hoses is also an option.*

2. Remove drain tubing from bottom of inducer housing.
3. Remove rain gutter tubing from inducer outlet.
4. Remove tubing from condensate pressure switch.
5. Remove tubing from PS2 to cold header.

Furnace Combustion Air Exhaust Options

Figure117. Removing tubing

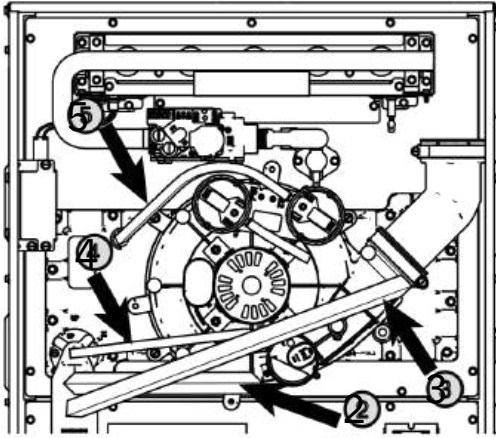

6. Remove two 3-inch plugs on left side of cabinet. To be used for combustion air and vent exhaust.
7. Install the two 3-inch plugs into the two 3-inch default openings on the top of the cabinet.

Figure118. Plug installation

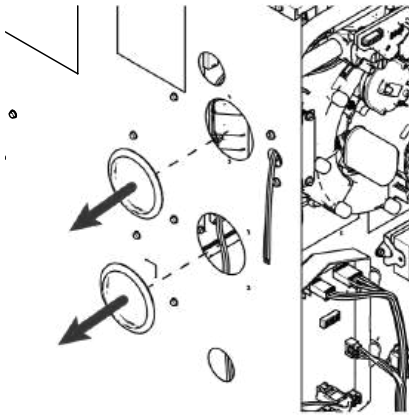

8. Loosen hose clamp and remove 45 degree adapter. If the rubber boot pulls out of the inducer opening, remove from the adapter and reinstall onto the inducer. Remove the elbow and discard.

Figure119. Replacing adapter and reinstalling the rubber boot

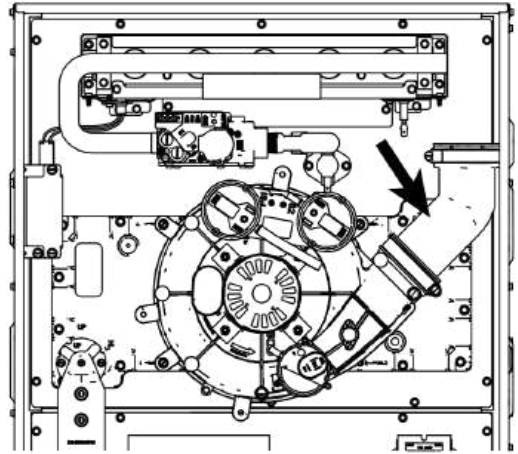

9. Remove the three inducer mounting screws.
10. Rotate inducer counter-clockwise so that the inducer outlet aligns with the exhaust vent outlet.
11. Insert and re-tighten screws to 30 in.-lbs. Do not over-tighten.

Figure 120. Re-tightening screws

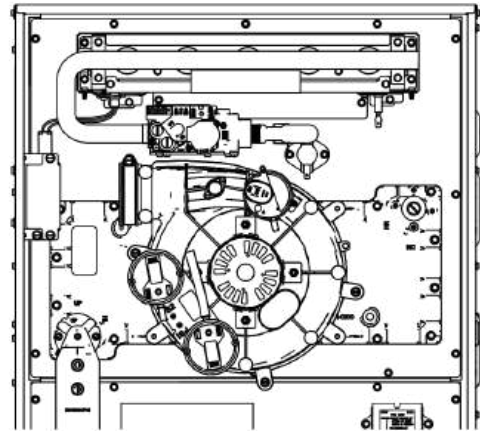

12. Remove the pressure switch bracket assembly.
13. Remove the screw that holds PS2, rotate 90 degrees clockwise, and reattach.
14. Reattach the pressure switch bracket assembly.

Note: Illustration below shows the PS2 pressure switch in the final rotated position.

Figure 121. PS2 pressure switch in the final rotated position

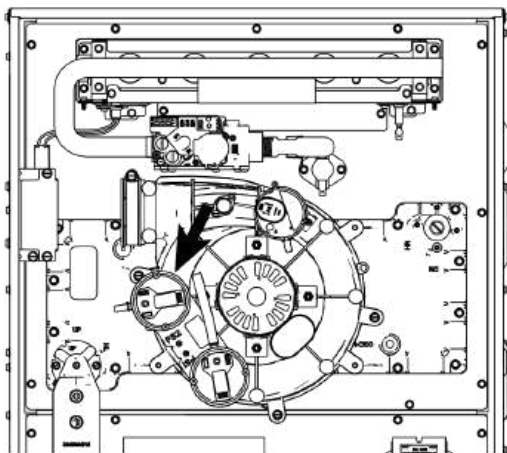

15. Attach the vent outlet gasket to the vent outlet.
16. Install vent outlet to top of cabinet using 2 screws supplied in the dock pack.
17. Install vent inlet gasket and vent inlet using 4 screws supplied in the dock pack.
18. Install the grommet for the condensate drain tube. The drain may be located on either side of the cabinet.

Figure 122. Install the vent inlet/outlet and grommet

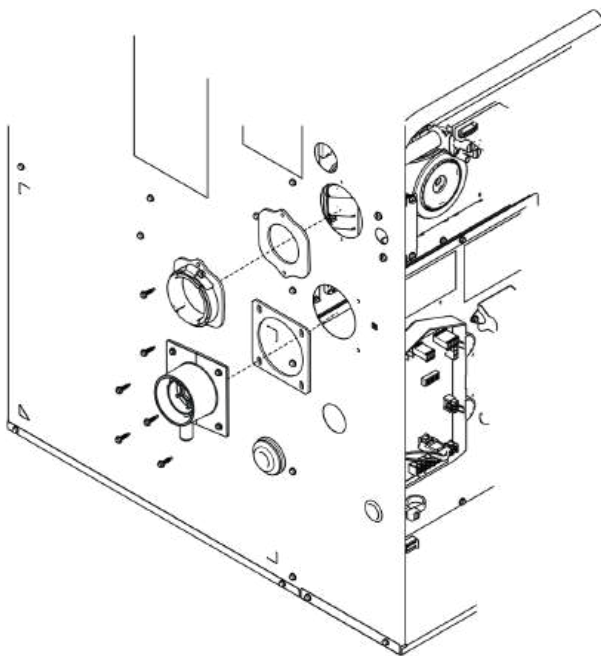

19. Slide PVC through vent outlet adaptor and insert into inducer outlet.
20. Twist to insure PVC is fully inserted.
21. Tighten the two clamps.

22. Install the combustion air inlet pipe.

Notes:

- The vent outlet adapter is used for strain relief against the weight of the venting. The clamp should be tightened after the internal connection is made.
- If required, transition to larger venting within 2ft of the cabinet. An 2-inchx 3-inch offset coupling is required if the transition is made in a horizontal plane. Use coupling CPL01544 (Canadian applications may use BAYREDUCE to meet ULC-S636 requirements.) See Horizontal Venting section for proper orientation of 2-inchx 3-inch offset coupling.

Figure 123. Installing the combustion air inlet pipe

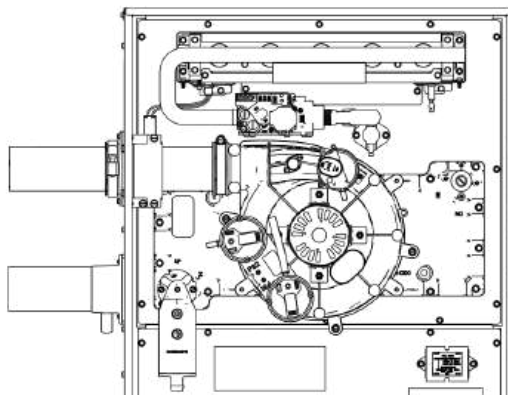

23. Connect PS2 tubing to switch and sensing location.
- Important:** Trim the PS2 pressure switch tubing to length to ensure there is no sag or trap created.
24. Remove port cap at bottom of inducer and connect inducer condensate tubing. Connect other end of inducer condensate tubing to top port on the condensate trap. Cut tubing to length, if necessary.
 25. Install previously removed port cap onto bottom port of the inducer. (As viewed in upflow)
 26. Connect condensate pressure switch tubing to pressure port on the condensate trap.
- Important:** Trim the condensate pressure switch tubing to length to ensure there is no sag or trap created.
27. Remove port plug from rain gutter and install in new position on opposite side of the rain gutter.
 28. Connect rain gutter condensate hose to the rain gutter and the lower port of the condensate trap. Cut to length, if necessary.

Furnace Combustion Air Exhaust Options

Figure 124. Condensate tubing

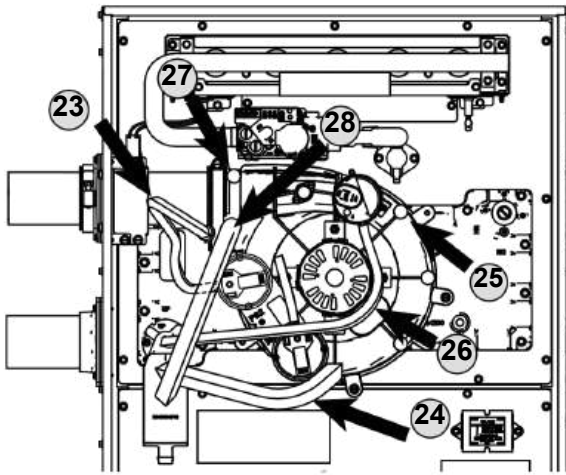

Note: When removing condensate hoses from the condensate trap, hold the trap with your hand to prevent the trap from breaking. Removing the trap before the hoses is also an option.

2. Remove tubing from PS2 to cold header. Remove
3. drain tubing from bottom of inducer housing. Remove
4. rain gutter tubing from inducer outlet. Remove tubing
5. from condensate pressure switch. Remove the
6. screws that hold the condensate trap bracket. The condensate trap should not be removed from the condensate trap bracket. Remove assembly and retain for later installation.

Note: There is a plastic adapter with O-rings located inside the cold header that is held in place by the condensate trap bracket. Do not lose this adapter. This adapter needs to be in place when the condensate trap bracket is reattached.

Figure 126. Removing tubing

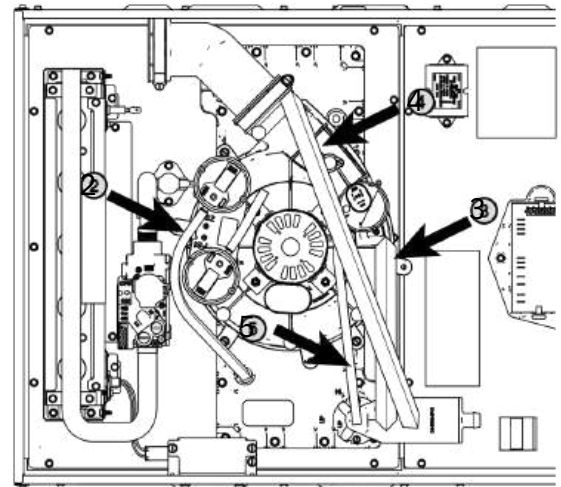

Horizontal Left Position - Side Vented Combustion Air

Changes need to be made to the inducer orientation when installing the upflow furnace in the horizontal left position with the combustion air vented through the side. Additional changes are needed for hose routing, condensate trap orientation, and inducer hoses.

The figure to the top right shows the furnace as it is sent from the factory.

Use the following steps to modify the furnace for horizontal left with side venting of combustion air.

Important: PS2 conversion does not apply to the S9X1 or S9B1 models.

Figure 125. Horizontal left position-sidevented combustion air

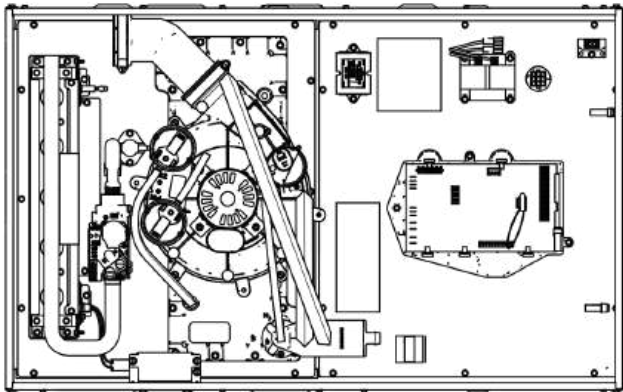

Before proceeding, lay unit on its back to make the conversion easier.

1. Remove all drain hoses from condensate trap.

7. Loosen hose clamp and remove 45 degree adapter. If the rubber boot pulls out of the inducer opening, remove from the adapter and reinstall onto the inducer. Remove the elbow and discard.

Figure 127. - Replacing adapter and reinstalling the rubber boot

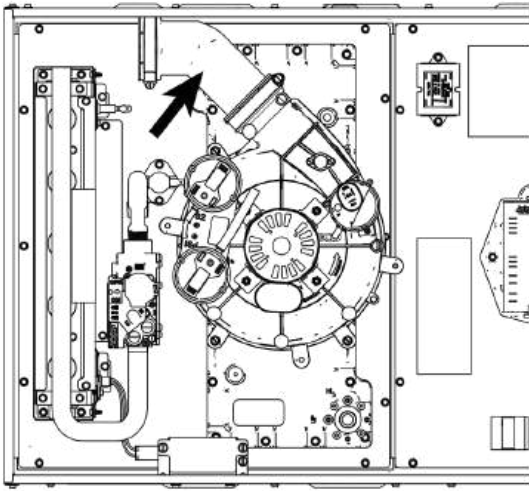

8. Remove three inducer screws.
9. Rotate the inducer so that the outlet is pointing vertically.
10. Use the three screws to reattach the inducer to the cold header to 30 in.-lbs. Do not overtighten.

Figure 128. Reattaching the inducer

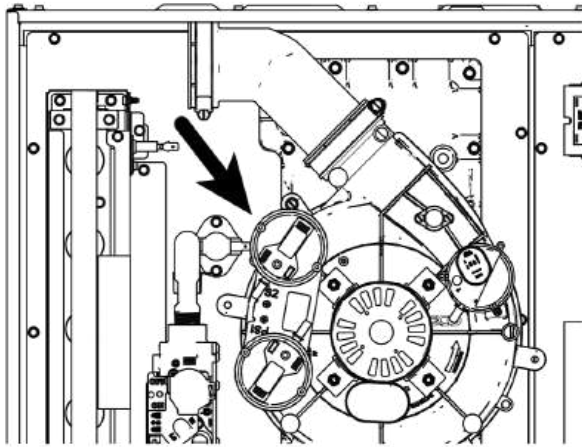
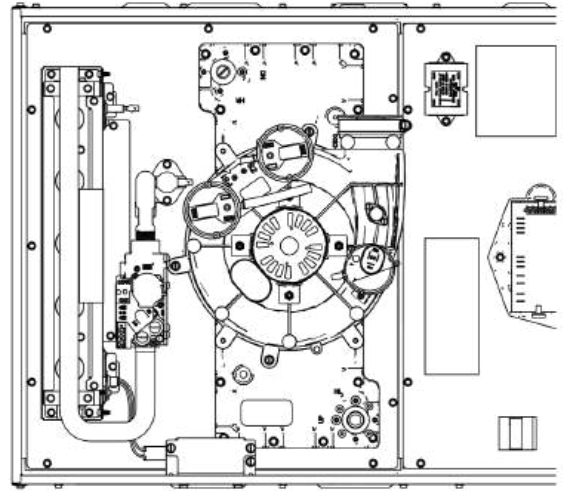
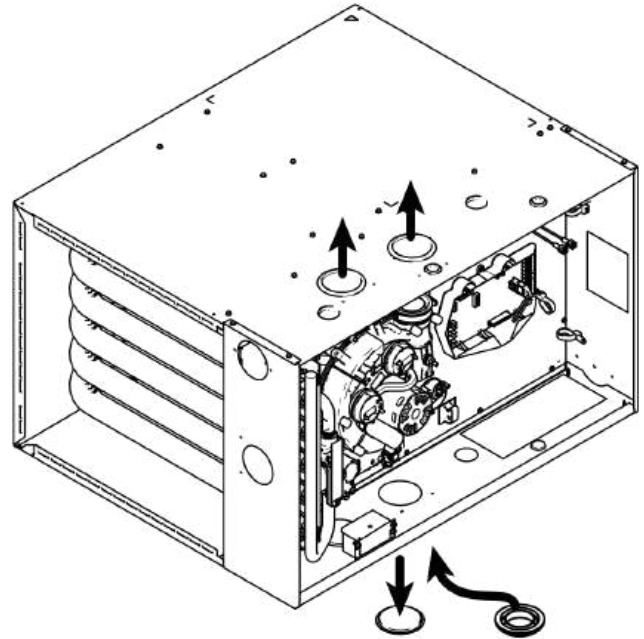

Figure 129. Reattaching the inducer



11. Remove 3-inch plug on left side of unit. To be used for condensate trap.
12. Install condensate trap grommet.
13. Remove two 3-inch plugs on right side of cabinet. To be used for combustion air exhaust and inlet.
14. Reuse the two 3-inch plugs to seal the two 3-inch default openings on the top of the furnace.

Figure 130. Sealing the default openings



15. Attach the vent outlet gasket to the vent outlet.
16. Install vent outlet to top of cabinet using 2 screws supplied in the dock pack.

Furnace Combustion Air Exhaust Options

17. Install vent inlet gasket and vent inlet using 4 screws supplied in the dock pack.

Figure 131. Install the vent inlet/outlet

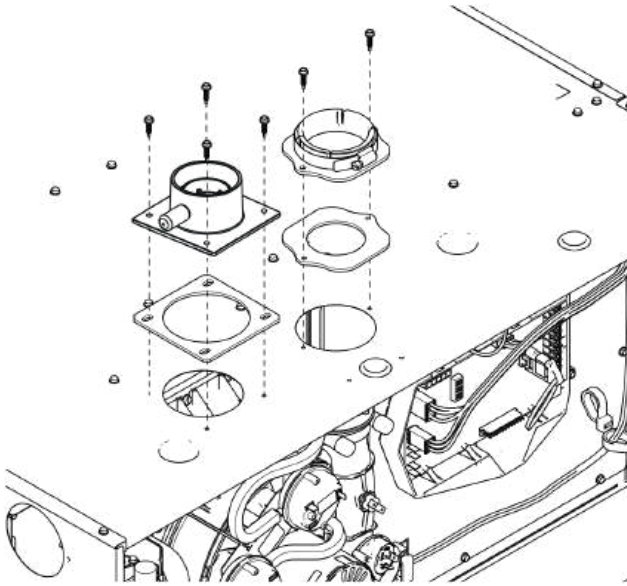

18. Slide PVC through vent outlet adaptor and insert into inducer outlet.
19. Twist to insure PVC is fully inserted.
20. Tighten the two clamps.
21. Install the combustion air inlet PVC pipe.

Notes:

- The vent outlet adaptor is used for strain relief against the weight of the venting. The clamp should be tightened after the internal connection is made.
- If required, transition to larger venting within 2ft of the cabinet. CPL01544 – 2-inch x 3-inch offset coupling may be used and is factory supplied with 120 MBTUH furnaces. Canadian applications may use BAYREDUCE to meet ULC-S636 requirements.

Figure 132. Installing the combustion air inlet PVC pipe

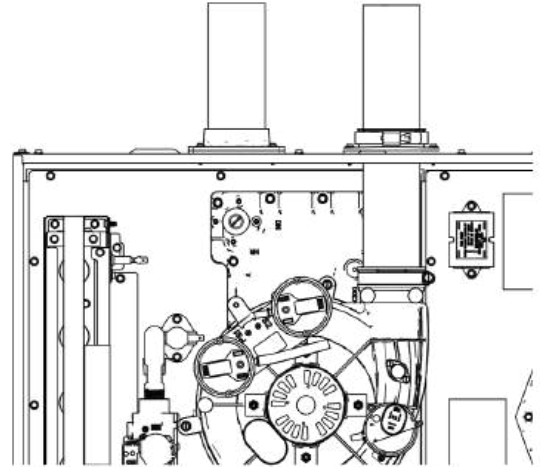

22. Reinstall the condensate adapter if it was earlier removed or ensure adapter is still in place.

Important: The condensate adapter must be present for proper condensate drain operation.

23. Install condensate trap into new location by fitting into grommet and aligning the hole on the condensate trap with the hole labeled "HL".

Important: When installing a 21.0-inch wide S-Series furnace, the condenser trap grommet must be rotated so that the notch in the grommet faces the outer edge of the furnace cabinet as shown in the illustrations below and to the top left in next page. This allows the rain gutter tubing to fully seat onto the lower condensate port trap.

24. Hand tighten screw with a 1/4-inch nut driver. Do not over torque or use a drill gun.

Figure 133. Grommet

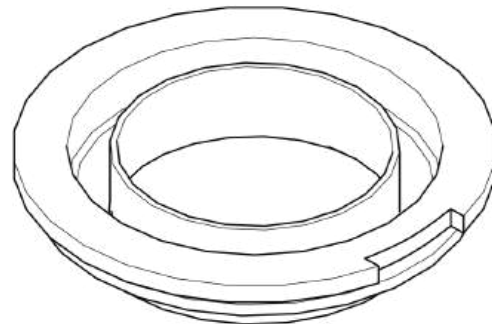

Figure 134. Tightening screw

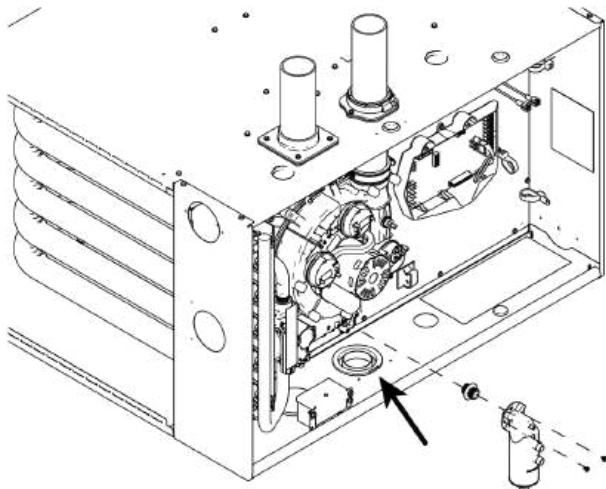
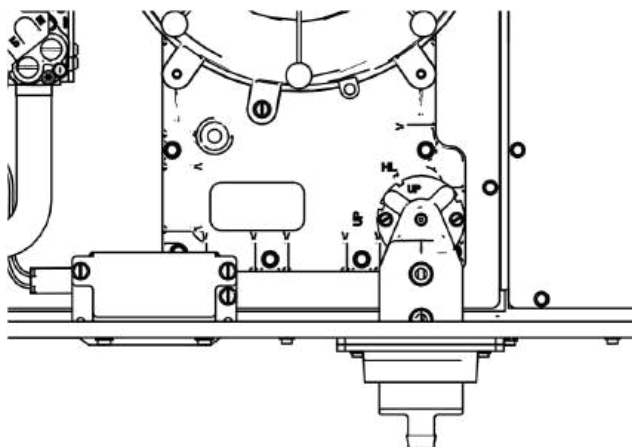

Figure 135. Tightening screw



25. Connect PS2 tubing to switch and new sensing location.

Important: Trim the PS2 pressure switch tubing to length to ensure there is no sag or trap created.

26. Remove port cap on left of inducer and connect inducer condensate tubing. Connect other end of inducer condensate tubing to top port on the condensate trap. Cut tubing to length, if necessary.

27. Install previously removed port cap onto bottom port of the inducer.

28. Connect condensate pressure switch tubing to pressure port on the condensate trap.

Important: Trim the condensate pressure switch tubing to length to ensure there is no sag or trap created.

29. Connect rain gutter condensate hose to the rain gutter and the lower port of the condensate trap.

Figure 136. Condensate tubing

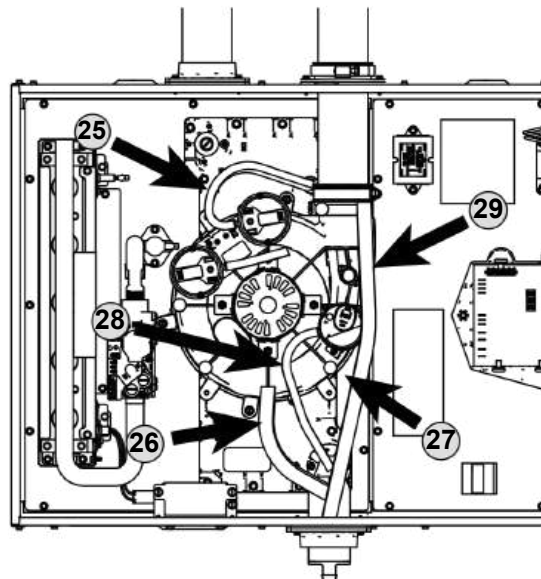

Furnace in Horizontal Left Position - Top Vented Combustion Air

Changes do not need to be made to the inducer orientation when installing the upflow furnace in the horizontal left position with the combustion air vented through the top. Changes are needed for hose routing, condensate trap orientation, and inducer port caps.

The figure below shows the furnace as it is sent from the factory.

Use the following steps to modify the furnace for horizontal left with top venting of combustion air.

Important: PS2 conversion does not apply to the S9X1 or S9B1 models.

Figure 137. Horizontal left position - top vented combustion air

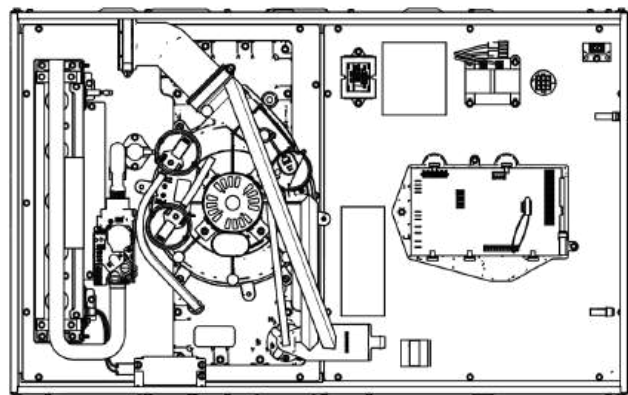

Before proceeding, lay unit on its back to make the conversion easier.

Furnace Combustion Air Exhaust Options

1. Remove all drain hoses from condensate trap.
- Note:** When removing condensate hoses from the condensate trap, hold the trap with your hand to prevent the trap from breaking. Removing the trap before the hoses is also an option.
2. Remove tubing from PS2 to cold header. Remove
 3. drain tubing from bottom of inducer housing. Remove
 4. rain gutter tubing from inducer outlet. Remove tubing
 5. from condensate pressure switch. Remove the
 6. screws that hold the condensate trap bracket. The condensate trap should not be removed from the condensate trap bracket. Remove assembly and retain for later installation.

Note: There is a plastic adapter with O-rings located inside the cold header that is held in place by the condensate trap bracket. Do not lose this adapter. This adapter needs to be in place when the condensate trap bracket is reattached.

Figure 138. Removing tubing

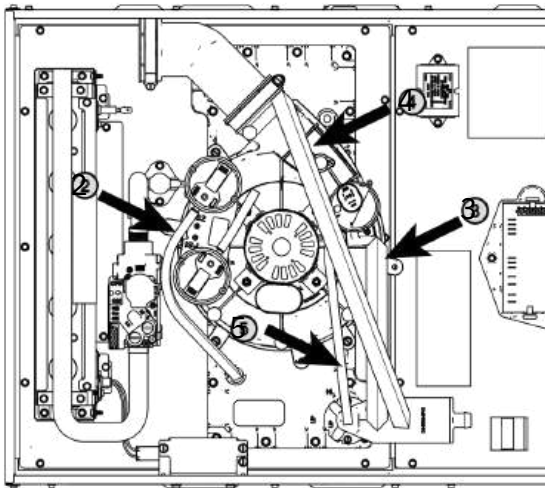

7. Remove plug from 3-inch hole.
8. Install condensate trap grommet.

Figure 139. Installing condensate trap grommet

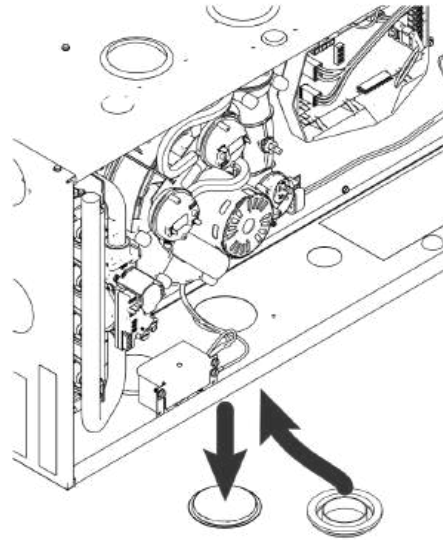

9. Remove the pressure switch bracket assembly.
10. Remove the screw that holds PS2, rotate 90 degrees clockwise, and reattach.
11. Reattach the pressure switch bracket assembly.

Figure 140. Pressure switch bracket assembly

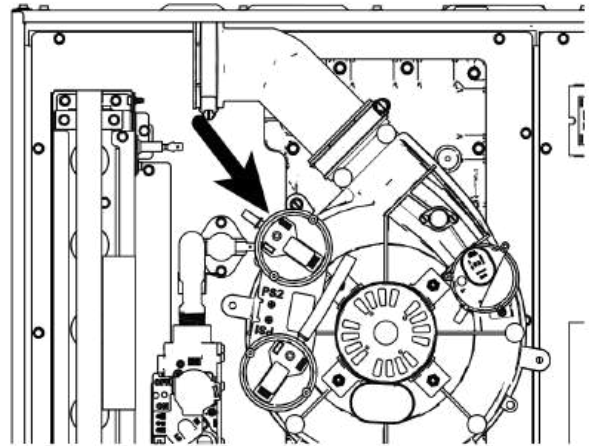

12. Attach the vent outlet gasket to the vent outlet.
13. Install vent outlet to top of cabinet using 2 screws supplied in the doc pack.
14. Install vent inlet gasket and vent inlet using 4 screws supplied in the doc pack.

Figure 141. Install the vent inlet/outlet

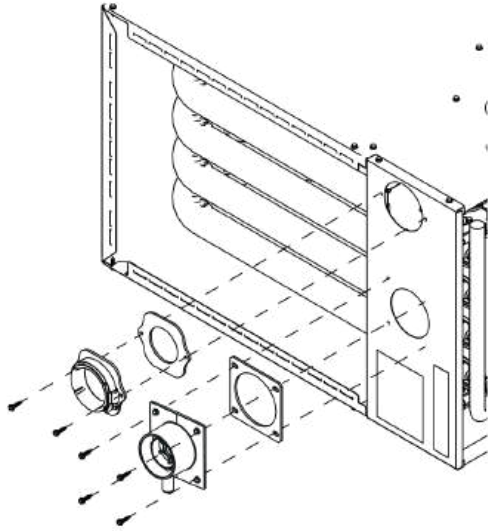

15. Remove the cap on the cap on the top side of the cold header and move it to the bottom position on the cold header.
16. Slide PVC through vent outlet adaptor and insert into inducer outlet.
17. Twist to insure PVC is fully inserted.
18. Tighten the two clamps.
19. Install the combustion air inlet PVC pipe.

Notes:

- *The vent outlet adapter is used for strain relief against the weight of the venting. The clamp should be tightened after the internal connection is made.*
- *If required, transition to larger venting within 2ft of the cabinet. An 2-inch x 3-inch offset coupling is required if the transition is made in a horizontal plane. Use coupling CPL01544 (Canadian applications may use BAYREDUCE to meet ULC-S636 requirements.) See Horizontal Venting section for proper orientation of 2-inch x 3-inch offset coupling.*

Figure 142. Install the combustion air inlet PVC pipe

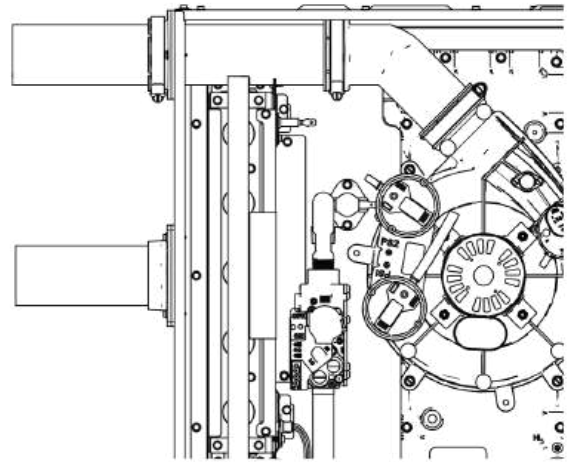

20. Reinstall the condensate adapter if it was earlier removed or ensure adapter is still in place.

Important: *The condensate adapter must be present for proper condensate drain operation.*

21. Install condensate trap into new location by fitting into grommet and aligning the hole on the condensate trap with the hole labeled "HL".

When installing a 21.0-inch wide S-Series furnace, the condenser trap grommet must be rotated so that the notch in the grommet faces the outer edge of the furnace cabinet as shown in the illustrations below and to the top left in next page. This allows the rain gutter tubing to fully seat onto the lower condensate port trap.

22. Hand tighten screw with a 1/4-inch nut driver. Do not over torque or use a drill gun.

Figure 143. Grommet

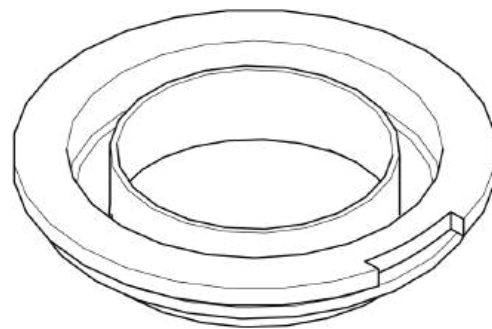

Furnace Combustion Air Exhaust Options

Figure 144. Tightening screws

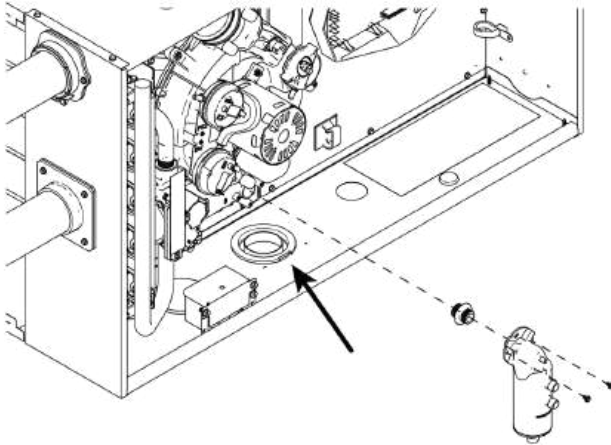
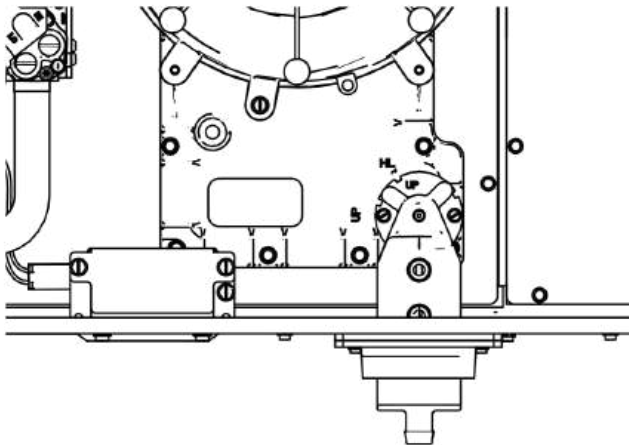

Figure 145. Tightening screws



23. Connect PS2 tubing to switch and new sensing location.

Important: Cut to length but insure there is a rise in the tubing to avoid condensed flue gases from entering pressure switch.

24. Remove port cap on left side of inducer and connect inducer condensate tubing. Connect other end of inducer condensate tubing to top port on the condensate trap. Cut tubing to length, if necessary.

25. Install previously removed port cap onto bottom port of the inducer. (As viewed in upflow)

26. Connect condensate pressure switch tubing to pressure port on the condensate trap.

Important: Trim the PS2 pressure switch tubing to length to ensure there is no sag or trap created.

27. Remove port plug from rain gutter and install in new position on opposite side of the rain gutter.

28. Connect rain gutter condensate hose to the rain gutter and the lower port of the condensate trap. Route rain gutter condensate hose to the right of the inducer motor.

Figure 146. Condensate tubing

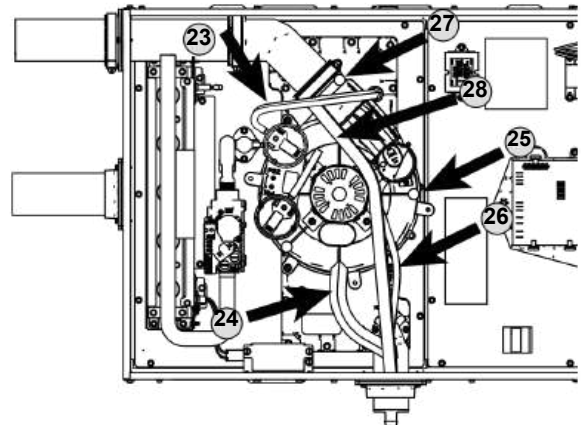

Furnace in Horizontal Right Position - Top Vented Combustion Air

Changes need to be made to the inducer orientation when installing the upflow furnace in the horizontal right position with the combustion air vented through the left side. Additional changes are needed for hose routing, condensate trap location, and inducer port caps, and the condensate plug.

The figure below shows the furnace as it is sent from the factory.

Use the following steps to modify the furnace for horizontal right with left side venting of combustion air.

Important: PS2 conversion does not apply to the S9X1 or S9B1 models.

Figure 147. Horizontal right position-topvented combustion air

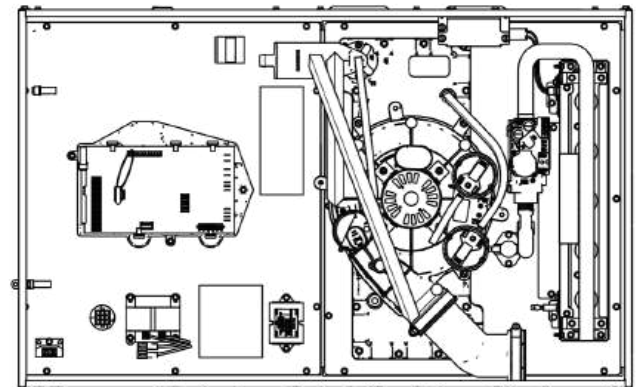

Before proceeding, lay unit on its back to make the conversion easier.

1. Remove all drain hoses from condensate trap.

Note: When removing condensate hoses from the condensate trap, hold the trap with your hand to prevent the trap from breaking. Removing the trap before the hoses is also an option.

2. Remove tubing from PS2 to cold header.
3. Remove drain tubing from bottom of inducer housing.
4. Remove rain gutter tubing from inducer outlet.
5. Remove tubing from condensate pressure switch.
6. Remove the screws that hold the condensate trap bracket. The condensate trap should not be removed from the condensate trap bracket. Remove assembly and retain for later installation.
7. Remove the adapter located inside the condensate trap connection on the cold header and retain for later installation.

Note: The plastic adapter with O-rings located inside the cold header that is held in place by the condensate trap bracket. Do not lose this adapter. This adapter needs to be in place when the condensate trap bracket is reattached.

Figure 148. Removing tubing

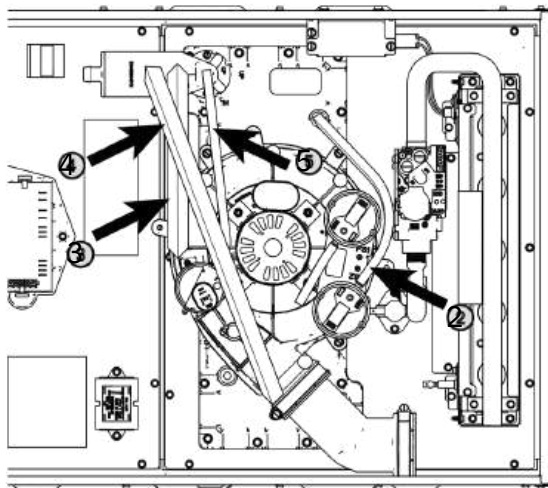

8. Remove 3-inch plug on right side of unit. To be used for condensate trap.
9. Install condensate trap grommet.
10. Remove two 3-inch plugs on left side of cabinet.
11. Reuse the two 3-inch plugs to seal the two 3-inch default openings on the top of the cabinet.

Figure 149. Sealing default openings

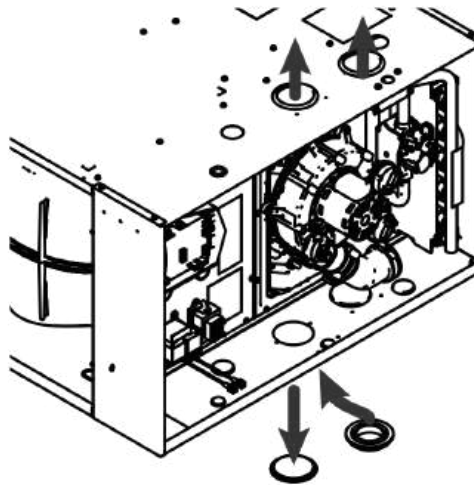

12. Attach the vent outlet gasket to the vent outlet.
13. Install vent outlet to top of cabinet using 2 screws supplied in the doc pack.
14. Install vent inlet gasket and vent inlet using 4 screws supplied in the doc pack.

Figure 150. Install the vent inlet/outlet

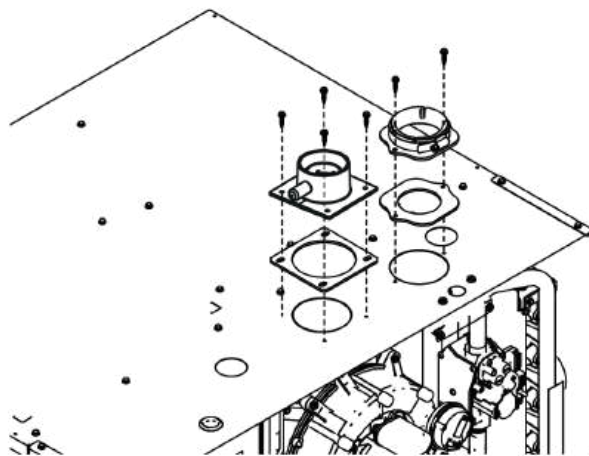

15. Remove three inducer screws.
16. Loosen hose clamp and remove 45 degree adapter. If the rubber boot pulls out of the inducer opening, remove from the adapter and reinstall onto the inducer.
17. Rotate the inducer so that the outlet is pointing vertically.
18. Use the three inducer screws to reattach the inducer to the cold header. Torque to 30 in.-lbs. Do not overtighten.

Furnace Combustion Air Exhaust Options

Figure 151. Reattaching the inducer

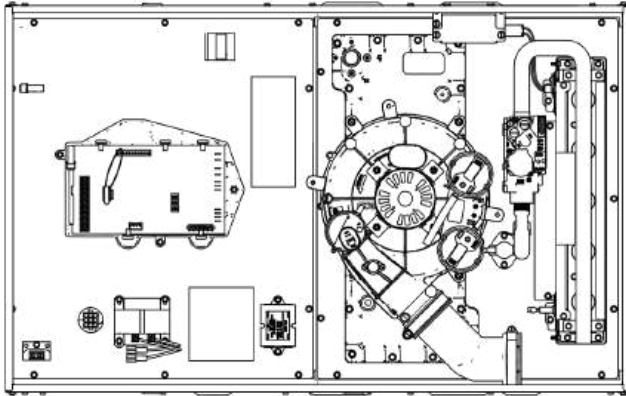
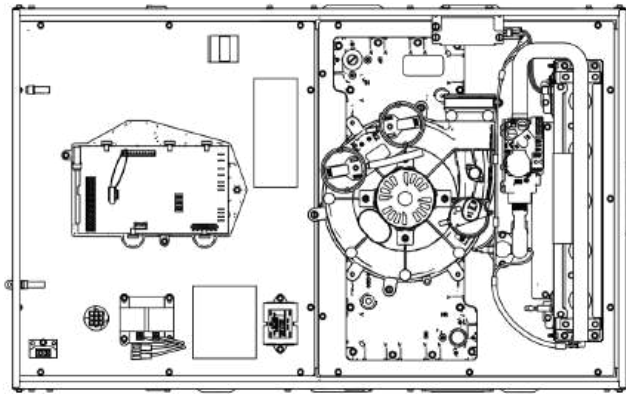
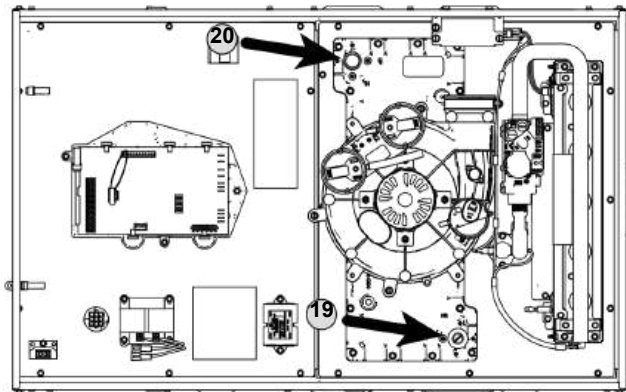

Figure 152. Reattaching the inducer



19. Remove condensate drain plug from top right location on cold header.
20. Place condensate drain plug onto the cold header outlet located on the bottom left of the cold header.

Figure 153. Condensate drain plug



21. Slide PVC through vent outlet adaptor and insert into inducer outlet.
22. Twist to insure PVC is fully inserted.
23. Tighten the two clamps.
24. Install the combustion air inlet PVC pipe.

Notes:

- The vent outlet adapter is used for strain relief against the weight of the venting. The clamp should be tightened after the internal connection is made.
- If required, transition to larger venting within 2ft of the cabinet. CPL01544 – 2-inch x 3-inch offset coupling may be used and is factory supplied with 120 MBTUH furnaces. Canadian applications may use BAYREDUCE to meet ULC-S636 requirements.

Figure 154. Install the combustion air inlet PVC pipe

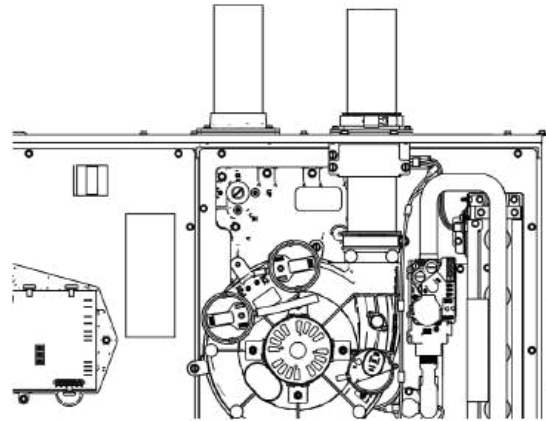

Condensate Trap Installation

25. Reinstall the condensate adapter if it was earlier removed or ensure adapter is still in place.

Important: The condensate adapter must be present for proper condensate drain operation.

26. Install condensate trap into new location by fitting into grommet and aligning the hole on the condensate trap with the hole labeled "HR".

Important: When installing a 21.0"-inch wide S-Series furnace, the condenser trap grommet must be rotated so that the notch in the grommet faces the outer edge of the furnace cabinet as shown in the illustrations below and to the top left in next page. This allows the rain gutter tubing to fully seat onto the lower condensate port trap.

27. Hand tighten screw with a 1/4-inch nut driver. Do not over torque or use a drill gun.

Figure 155. Grommet

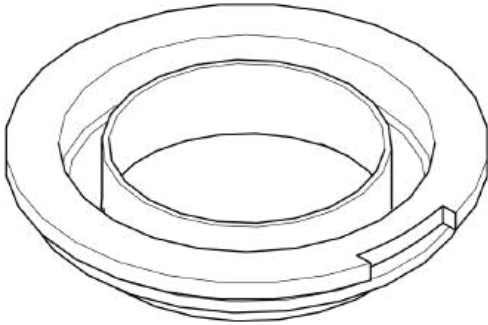

Figure 156. Tightening screws

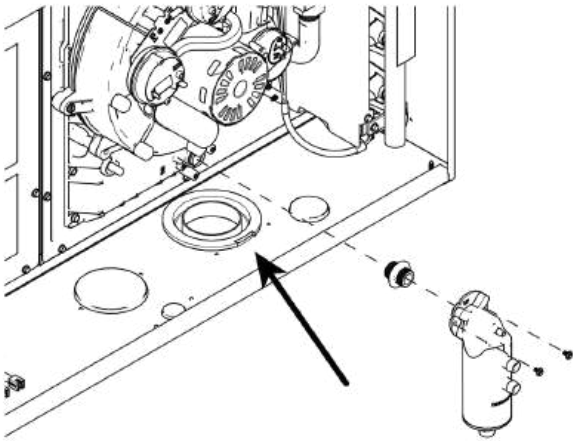
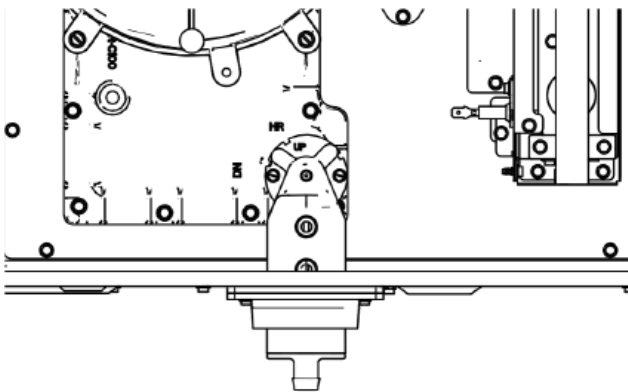

Figure 157. Tightening screws



28. Connect PS2 tubing to switch and new sensing location.

Important: Trim the PS2 pressure switch tubing to length to ensure there is no sag or trap created.

29. Remove port cap on the right side of the inducer and connect inducer condensate tubing. Connect other end

of inducer condensate tubing to top port on the condensate trap. Cut tubing to length, if necessary.

30. Install previously removed port cap onto bottom port of the inducer.

31. Connect condensate pressure switch tubing to pressure port on the condensate trap.

Important: Cut to length to ensure there is no sag or trap created.

32. Connect rain gutter condensate hose to the rain gutter and the lower port of the condensate trap.

Figure 158. Condensate tubing

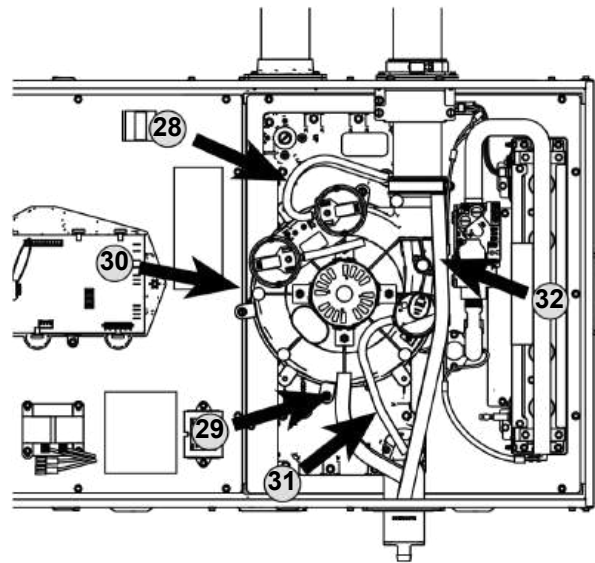

Furnace in Horizontal Right Position - Left Vented Combustion Air

Changes need to be made to the inducer orientation when installing the upflow furnace in the horizontal right position with the combustion air vented through the bottom. Additional changes are needed for hose routing, condensate trap location, and inducer port caps, and the condensate plug.

The figure below shows the furnace as it is sent from the factory.

Use the following steps to modify the furnace for horizontal right with bottom venting of combustion air.

Important: PS2 conversion does not apply to the S9X1 or S9B1 models.

Furnace Combustion Air Exhaust Options

Figure 159. Horizontal right position-left vented combustion air

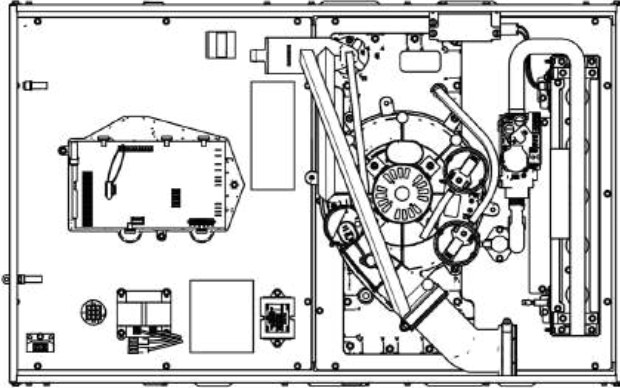

Before proceeding, lay unit on its back to make the conversion easier.

1. Remove all drain hoses from condensate trap.

Note: When removing condensate hoses from the condensate trap, hold the trap with your hand to prevent the trap from breaking. Removing the trap before the hoses is also an option.

2. Remove tubing from PS2 pressure switch. Remove
3. drain tubing from bottom of inducer housing. Remove
4. rain gutter tubing from inducer outlet. Remove tubing
5. from condensate pressure switch. Remove the
6. screws that hold the condensate trap bracket. The condensate trap should not be removed from the condensate trap bracket. Remove assembly and retain for later installation.
7. Remove the condensate adapter located inside the condensate trap connection on the cold header and retain for later installation.

Note: The plastic condensate adapter with O-rings located inside the cold header that is held in place by the condensate trap bracket. Do not lose this adapter. The condensate adapter needs to be in place when the condensate trap bracket is reattached.

Figure 160. Condensate tubing

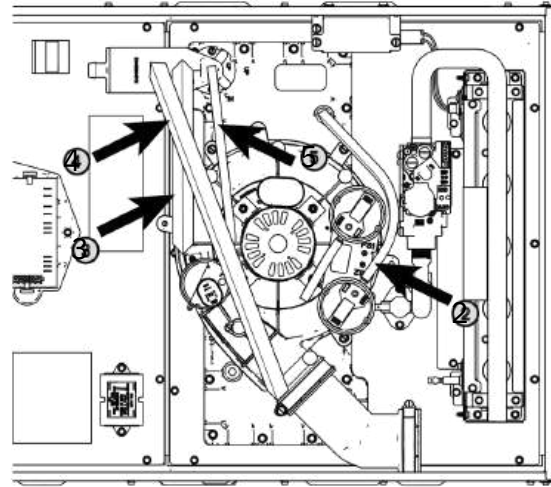

8. Remove 3-inch plug on right side of unit. To be used for condensate trap.
9. Install condensate trap grommet.
10. Remove 3-inch plugs on the left side of the cabinet. To be used for combustion air inlet.
11. Reuse the two 3-inch plugs to seal the two 3-inch default openings on the top of the furnace.

Figure 161. Sealing default openings

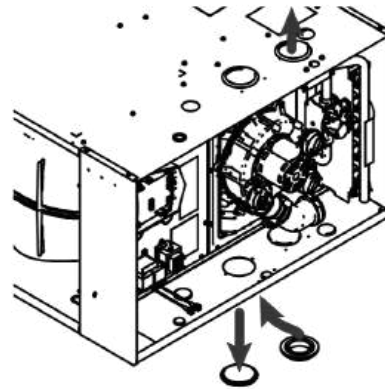

12. Remove three inducer screws.
13. While the inducer is loose, remove condensate drain plug from top right location on cold header.
14. Place condensate drain plug onto the cold header outlet located on the bottom left of the cold header.
15. Rotate the inducer 180 degrees so that the elbow is pointing towards the left.
16. Use the three inducer screws to reattach the inducer to the cold header. Torque to 30 in.-lbs. Do not overtighten.

Figure 162. Reattaching the inducer

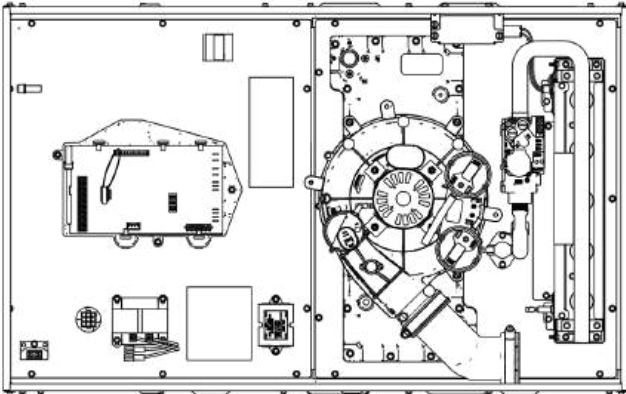

Figure 163. Reattaching the inducer

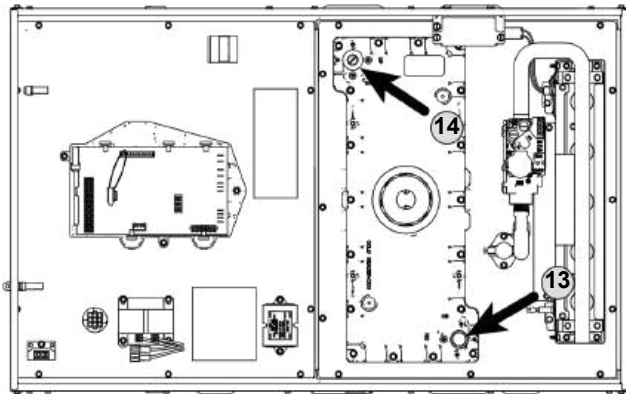
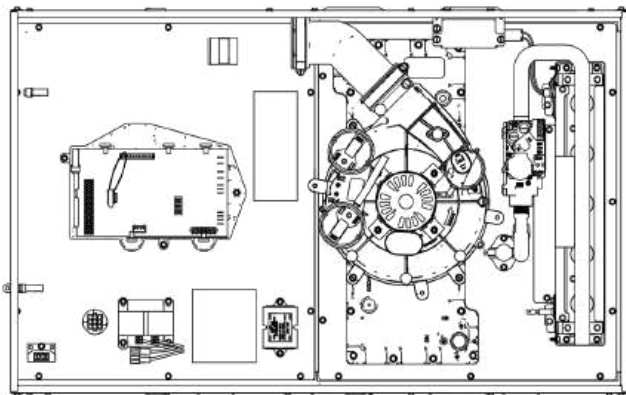

Figure 164. Reattaching the inducer



17. Remove the pressure switch bracket assembly.
18. Remove the screw that holds PS2, rotate 90 degrees clockwise, and reattach.
19. Reattach the pressure switch bracket assembly.

Note: *The inducer is shown rotated into its final position in the illustration below.*

Figure 165. Pressure switch bracket assembly

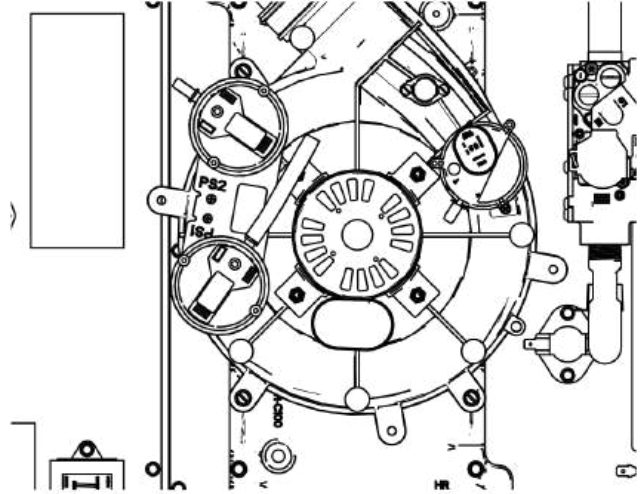

20. Cut 3-inch hole in bottom panel using large dimple as guide.

Figure 166. Cut hole

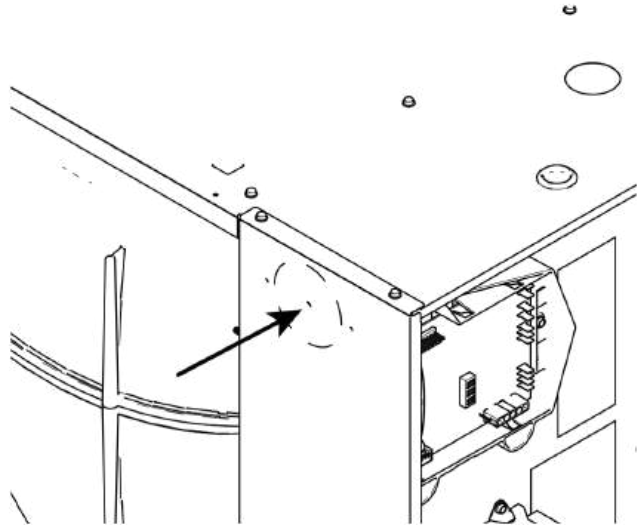

21. Attach the vent outlet gasket to the vent outlet.
22. Install vent outlet to top of cabinet using 2 screws supplied in the doc pack.
23. Install vent inlet gasket and vent inlet using 4 screws supplied in the doc pack.

Furnace Combustion Air Exhaust Options

Notes:

- The vent outlet adapter is used for strain relief against the weight of the venting. The clamp should be tightened after the internal connection is made.
- If required, transition to larger venting within 2ft of the cabinet. An 2-inch X 3-inch offset coupling is required if the transition is made in a horizontal plane. Use coupling CPL01544 (Canadian applications may use BAYREDUCE to meet ULC-S636 requirements.) See Horizontal Venting section for proper orientation of 2-inch X 3-inch offset coupling

Figure 167. Install the vent inlet/outlet

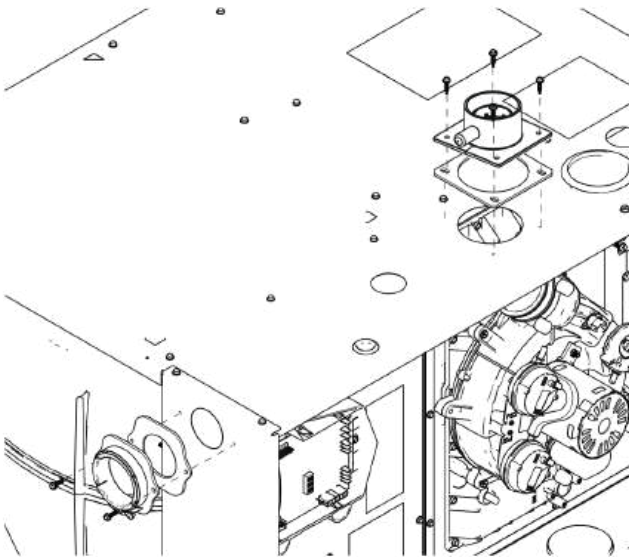

24. Slide PVC through vent outlet adaptor and insert into inducer outlet.
25. Twist to insure PVC is fully inserted.
26. Tighten the two clamps.
27. Install the combustion air inlet PVC pipe.

Figure 168. Install the combustion air inlet PVC pipe

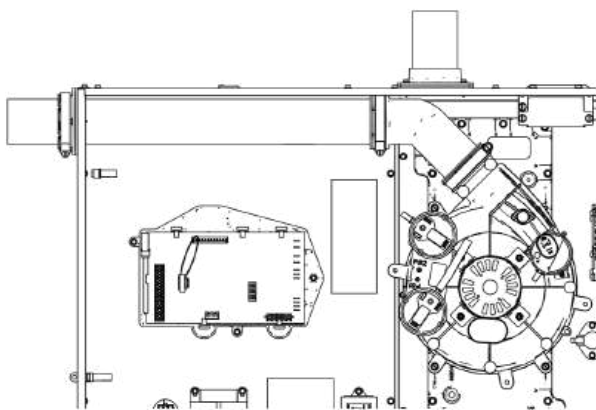

28. Reinstall the condensate adapter if it was earlier removed or ensure adapter is still in place.

Important: The condensate adapter must be present for proper condensate drain operation.

29. Install condensate trap into new location by fitting into grommet and aligning the hole on the condensate trap with the hole labeled "HR".

Important: When installing a 21.0-inchwide S-Series furnace, the condenser trap grommet must be rotated so that the notch in the grommet faces the outer edge of the furnace cabinet as shown in the illustrations below and to the top right. This allows the rain gutter tubing to fully seat onto the lower condensate port trap.

30. Hand tighten screw with a 1/4-inch nut driver. Do not over torque or use a drill gun.

Figure 169. Grommet

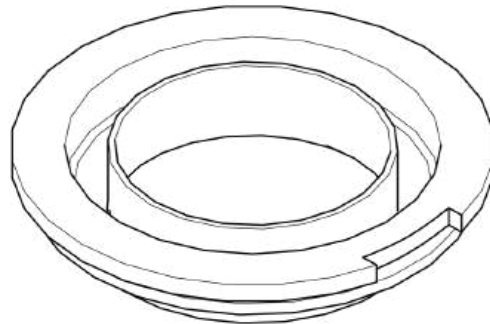

Figure 170. Tightening screws

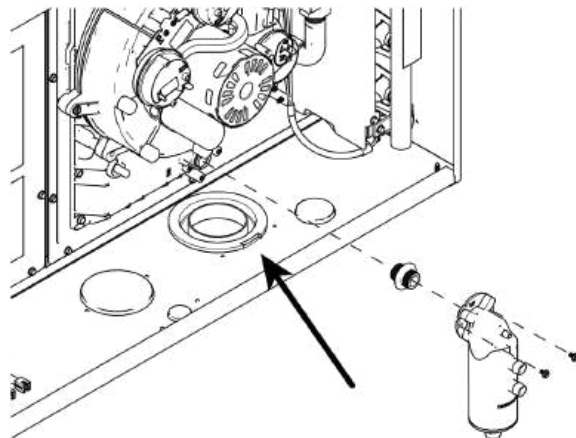
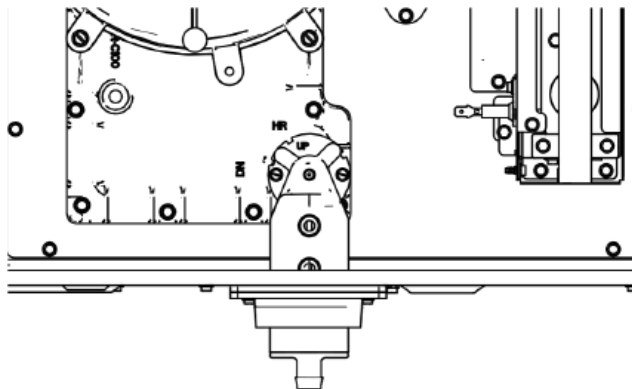

Figure 171. Tightening screws



31. Connect PS2 tubing to the PS2 switch and to the original sensing location on the cold header.

Important: *Trim the PS2 pressure switch tubing to length to ensure there is no sag or trap created.*

32. Remove port cap on the right side of inducer and connect inducer condensate tubing. Connect other end of inducer condensate tubing to top port on the condensate trap. Cut tubing to length, if necessary.

33. Install previously removed port cap onto bottom port of the inducer. (As viewed in upflow)

34. Connect condensate pressure switch tubing to pressure port on the condensate trap.

Important: *Cut to length to ensure there is no sag or trap created.*

35. Remove port plug from rain gutter and install in new position on opposite side of the rain gutter.

36. Connect rain gutter condensate hose to the rain gutter and the lower port of the condensate trap. Route rain gutter condensate hose to the right of the inducer motor.

Figure 172. Condensate tubing

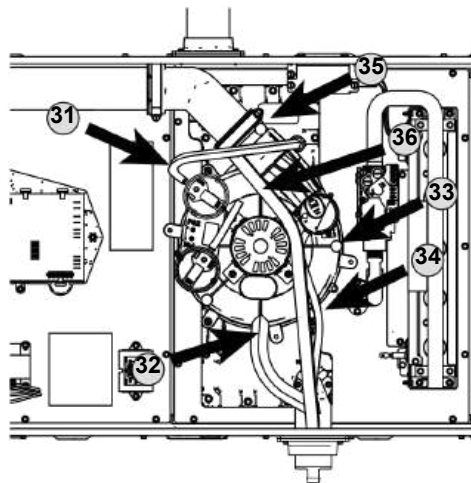

Downflow Furnace - Top Vented Combustion Air

No changes need to be made to the inducer when installing the downflow furnace with the combustion air vented through the top.

Important:

- *Trim the PS2 pressure switch tubing to length to ensure there is no sag or trap created.*
- *PS2 conversion does not apply to the S9X1 or S9B1 models.*

Figure 173. Downflow - top vented combustion air

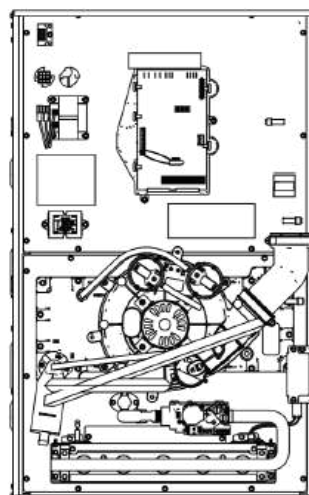

1. Attach the vent outlet gasket to the vent outlet.
2. Install vent outlet to top of cabinet using 2 screws supplied in the doc pack.
3. Install vent inlet gasket and vent inlet using 4 screws supplied in the doc pack.

Figure 174. Install the vent inlet/outlet

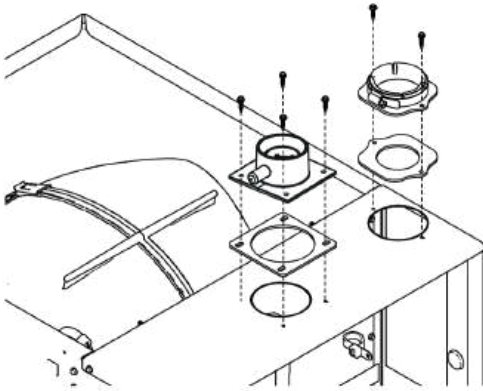

4. Slide PVC pipe through vent outlet adaptor and insert into inducer outlet.
5. Twist to insure PVC is fully inserted.
6. Tighten the two clamps.
7. Install the combustion air inlet PVC pipe.

Notes:

- The vent outlet adapter is used for strain relief against the weight of the venting. The clamp should be tightened after the internal connection is made.
- If required, transition to larger venting within 2' of the cabinet. CPL01544 – 2-inch X 3-inch offset coupling may be used and is factory supplied with 120 MBTUH furnaces. Canadian applications may use BAYREDUCE to meet ULC-S636 requirements.

Important: Trim the pressure switch tubing to length to ensure there is no sag or trap created.

Figure 175. Install the combustion air inlet PVC pipe

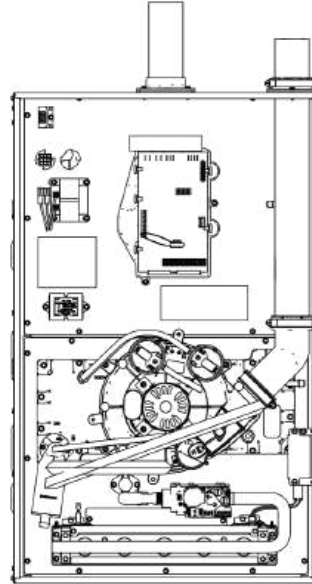

Downflow Furnace - Left Side Vented Combustion Air

Changes need to be made to the inducer orientation when installing the downflow furnace with the combustion air vented through the side. Additional changes are needed for hose routing and PS2 rotation.

The figure below shows the furnace as it is sent from the factory.

Use the following steps to modify the furnace for downflow with side venting of combustion air.

Important:

- Right side vent outlet is not allowed because condensate will not drain.
- PS2 conversion does not apply to the S9X1 or S9B1 models.

Figure 176. Downflow - left side vented combustion air

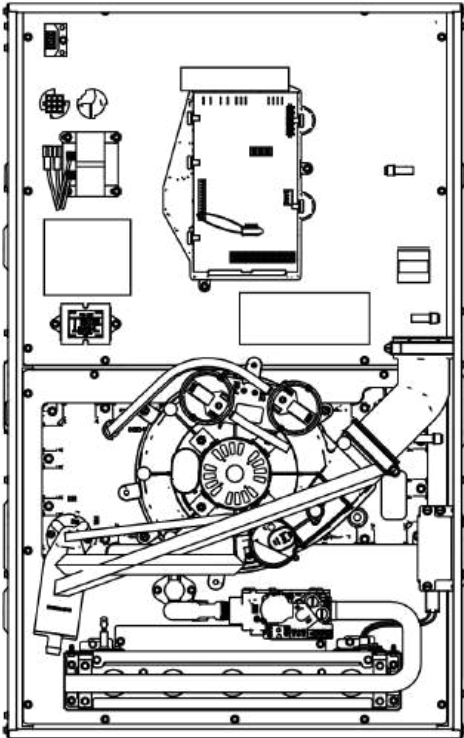

Before proceeding, lay unit on its back to make conversion easier.

1. Disconnect all drain tubes from condensate trap.

Notes:

- When removing condensate hoses from the condensate trap, hold the trap with your hand to prevent the trap from breaking.
- If preferred, the trap may be removed before the hoses.

2. Remove drain tubing from bottom of inducer housing.
3. Remove rain gutter tubing from inducer outlet.
4. Remove tubing from condensate pressure switch.
5. Remove tubing from PS2 to cold header.

Figure 177. Removing tubing

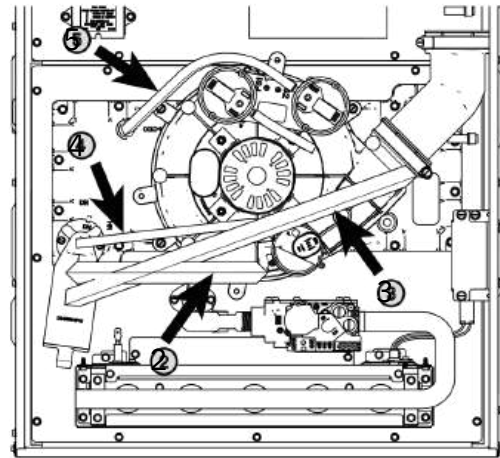

6. Remove two 3-inch plugs on left side of cabinet. To be used for combustion air exhaust and inlet.
7. Reuse the two 3-inch" plugs to seal the two 3-inch default openings on the top of the cabinet.

Figure 178. Sealing default openings

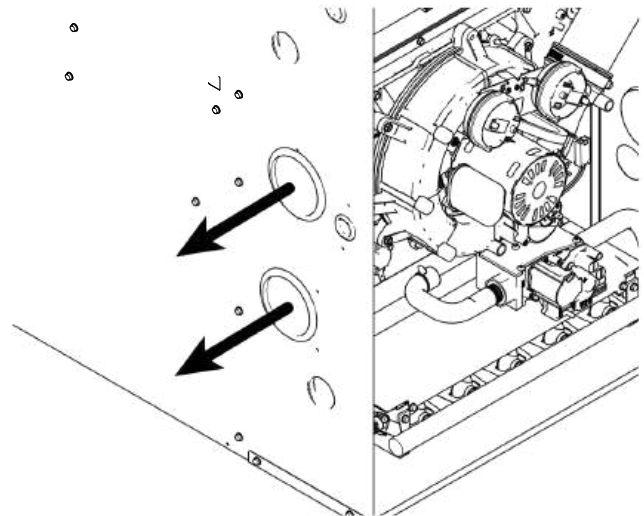

8. Loosen hose clamp and remove 45 degree adapter. If the rubber boot pulls out of the inducer opening, remove from the adapter and reinstall onto the inducer. Remove the elbow and discard.

Furnace Combustion Air Exhaust Options

Figure 179. Replacing adapter and reinstalling the rubber boot

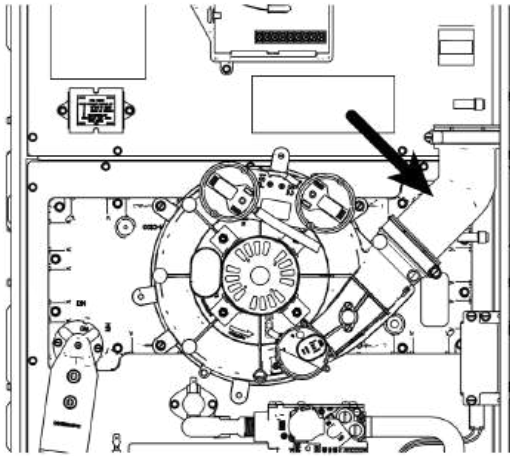

9. Remove the three inducer mounting screws.
10. Rotate inducer counterclockwise so that the inducer outlet aligns with the exhaust vent outlet.
11. Reinsert and tighten screws to 30 in.-lbs. Do not overtighten.

Figure 180. Reattach the inducer

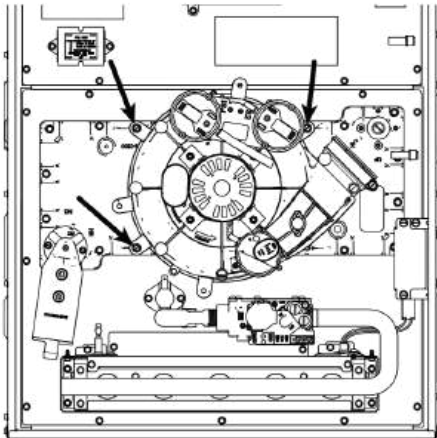
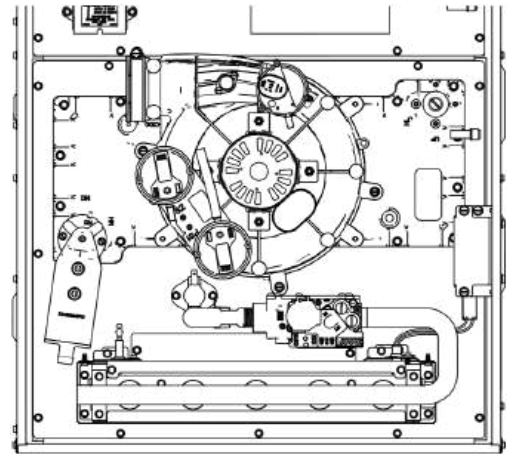

Figure 181. Reattach the inducer



12. Remove the pressure switch bracket assembly.
13. Remove the screw that holds PS2, rotate 90 degrees counterclockwise, and reattach.
14. Reattach the pressure switch bracket assembly.

Note: The illustration below shows PS2 in its final position after being rotated.

Figure 182. Reattach the pressure switch bracket assembly

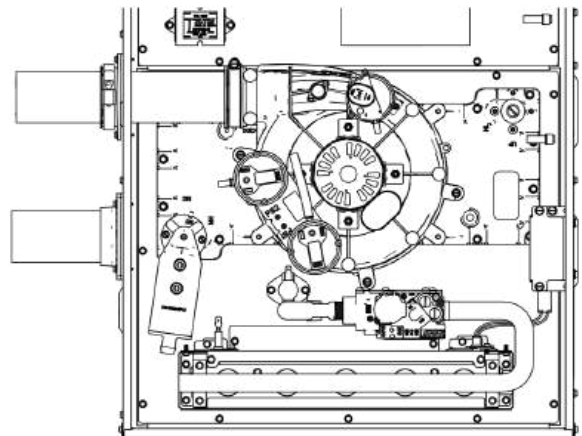

15. Attach the vent outlet gasket to the vent outlet.
16. Install vent outlet to cabinet using 2 screws supplied in the doc pack.
17. Install vent inlet gasket and vent inlet using 4 screws supplied in the doc pack.
18. Install the grommet for the condensate drain tube. The drain may be located on either side of the cabinet.

Figure 183. Install the vent inlet/outlet

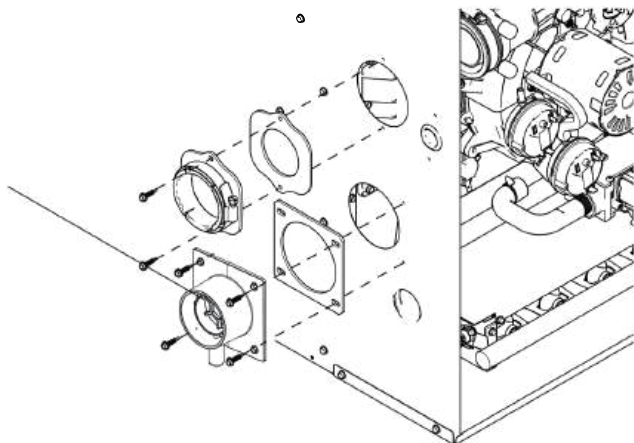

19. Slide PVC through vent outlet adaptor and insert into inducer outlet.
20. Twist to insure PVC is fully inserted.
21. Tighten the two clamps.
22. Install the combustion air inlet PVC pipe.

Notes:

- The vent outlet adapter is used for strain relief against the weight of the venting. The clamp should be tightened after the internal connection is made.
- If required, transition to larger venting within 2ft of the cabinet. An 2-inch X 3-inch offset coupling is required if the transition is made in a horizontal plane. Use coupling CPL01544 (Canadian applications may use BAYREDUCE to meet ULC-S636 requirements.) See Horizontal Venting section for proper orientation of 2-inch X 3-inch offset coupling.

Figure 184. Install the combustion air inlet PVC pipe

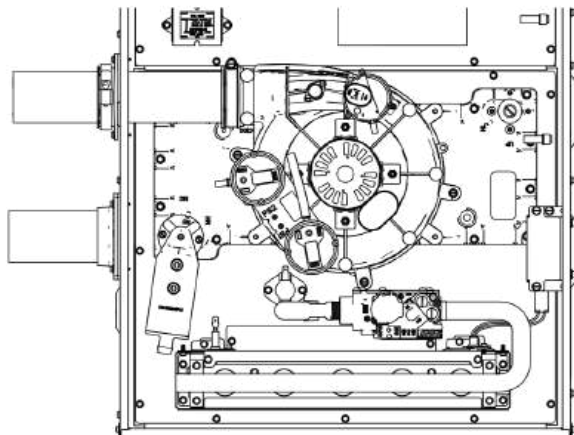

23. Connect PS2 tubing to switch and original sensing location.

Important: Trim the PS2 pressure switch tubing to length to ensure there is no sag or trap created.

24. Remove port cap at bottom of inducer and connect inducer condensate tubing. Connect other end of inducer condensate tubing to top port on the condensate trap. Cut tubing to length, if necessary.

25. Install previously removed port cap onto bottom port of the inducer.

26. Connect condensate pressure switch tubing to pressure port on the condensate trap.

Important: Trim the condensate pressure switch tubing to length to ensure there is no sag or trap created.

27. Remove port plug from rain gutter and install in new position on opposite side of the rain gutter.

28. Connect rain gutter condensate hose to the rain gutter and the lower port of the condensate trap. Cut to length, as required.

Figure 185. Condensate tubing

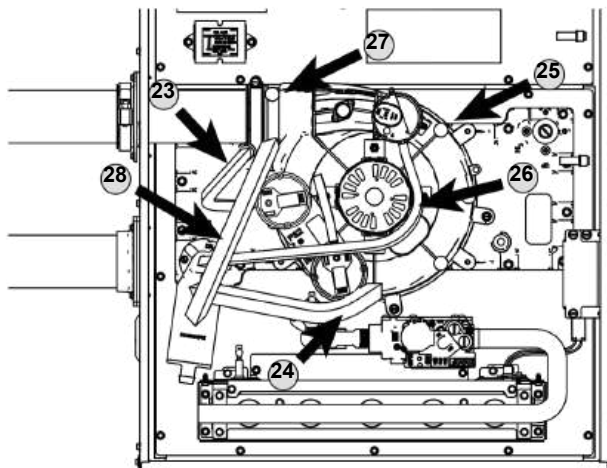

Integrated Furnace Control Menu

Figure 186. Control system menu single stage OD — S9X1/S9B1

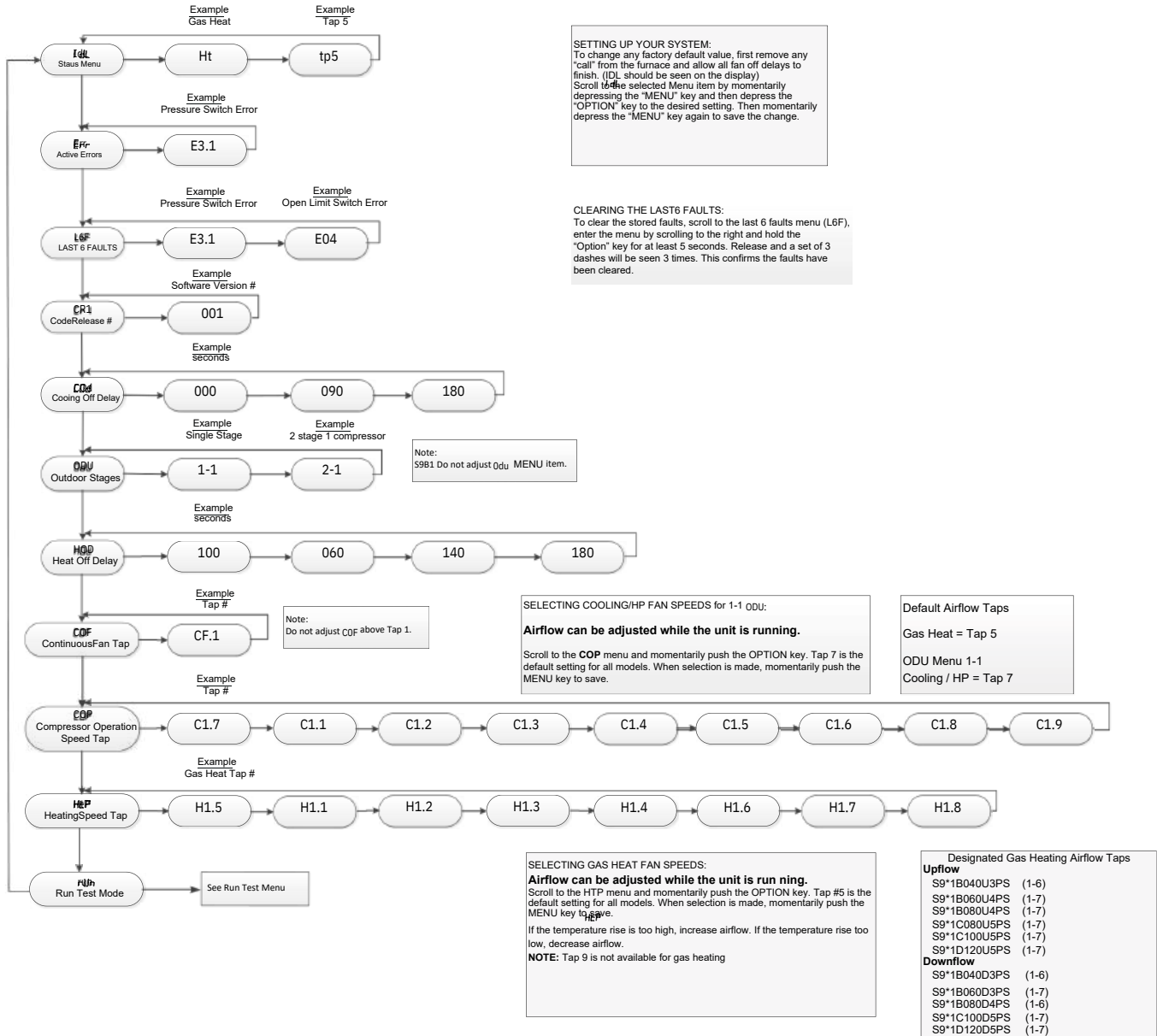
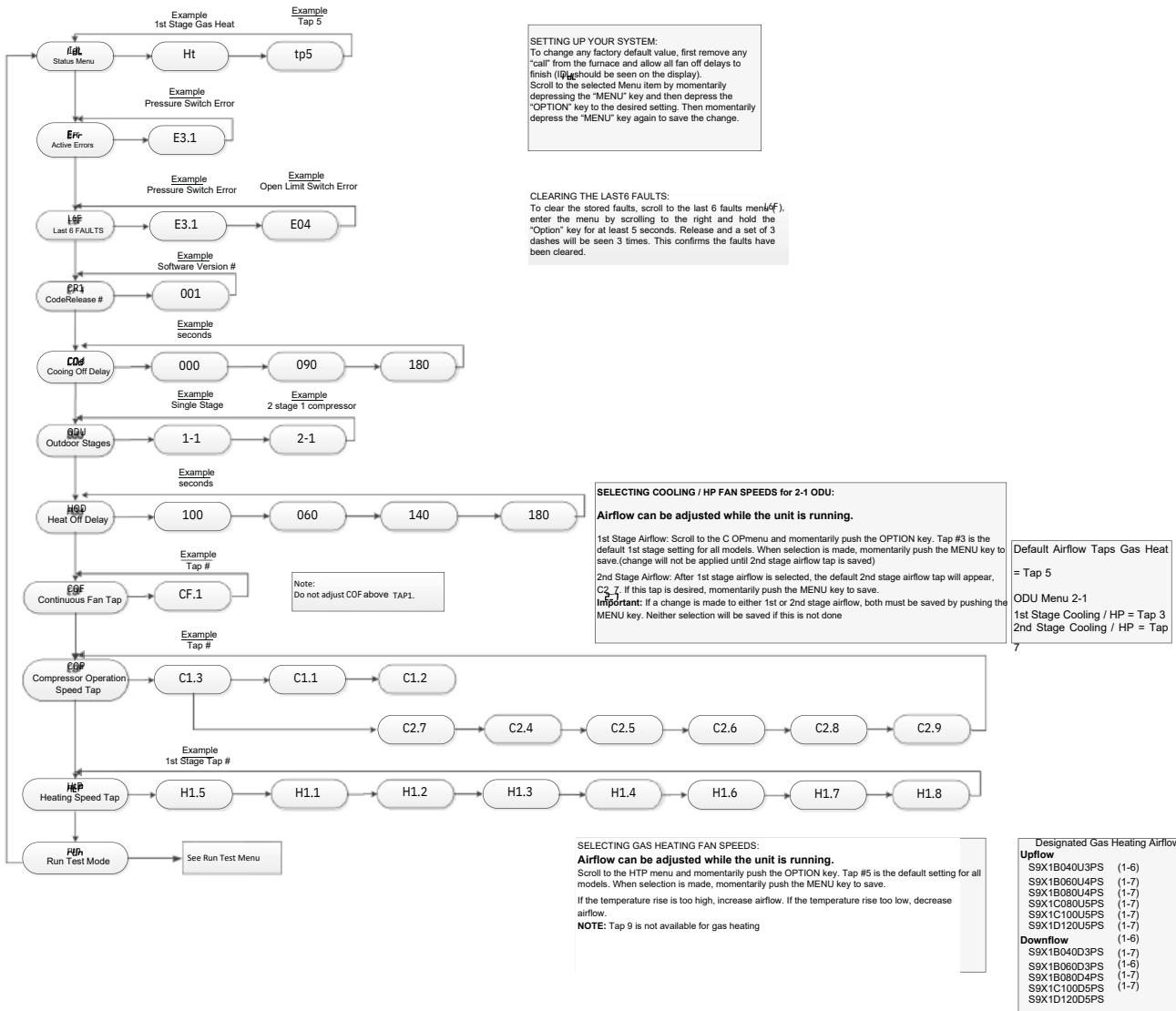

Figure 187. Control system menu two stage OD — S9X1



Integrated Furnace Control Menu

Figure 188. Control system single stage OD — S9X2

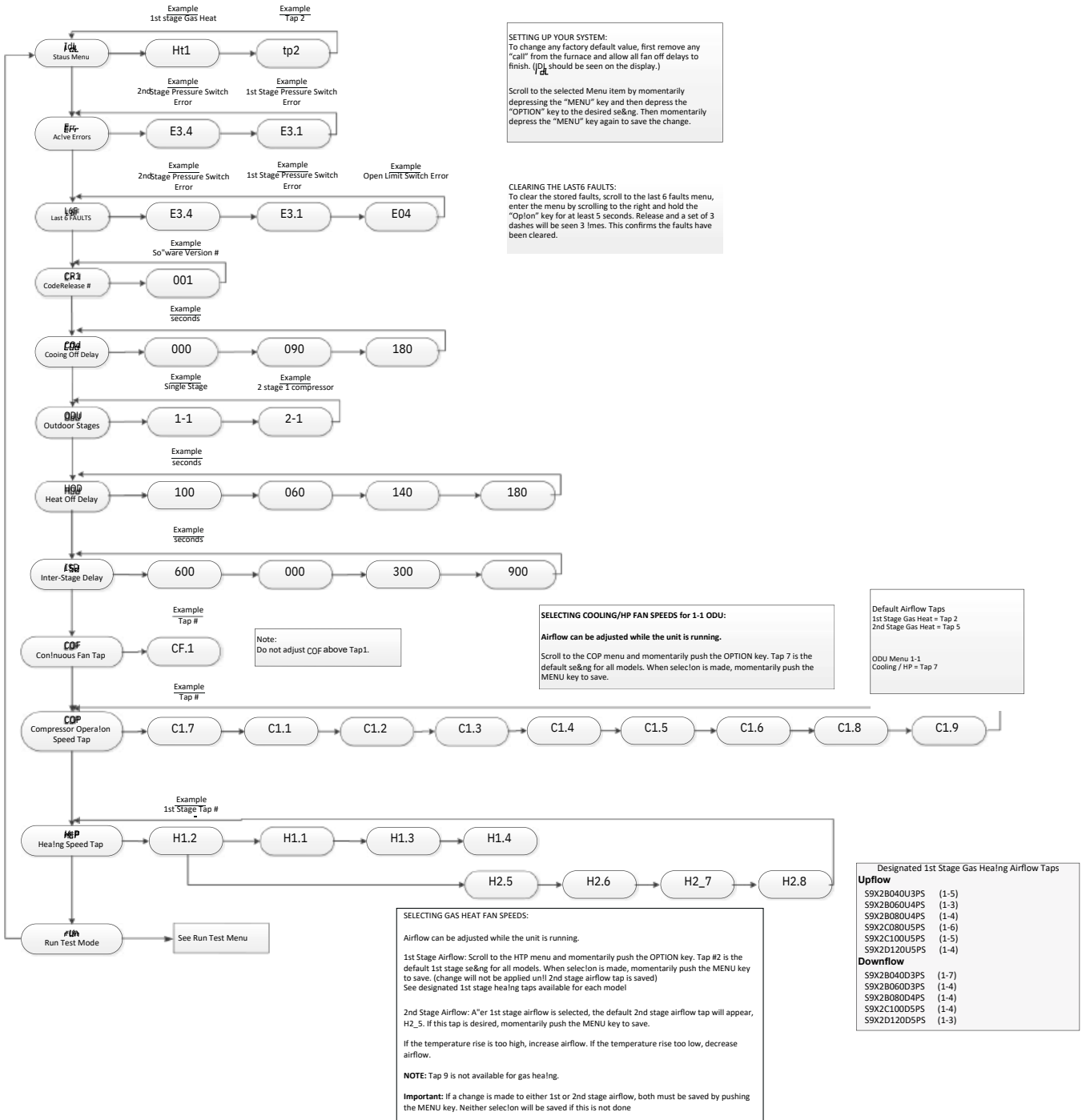
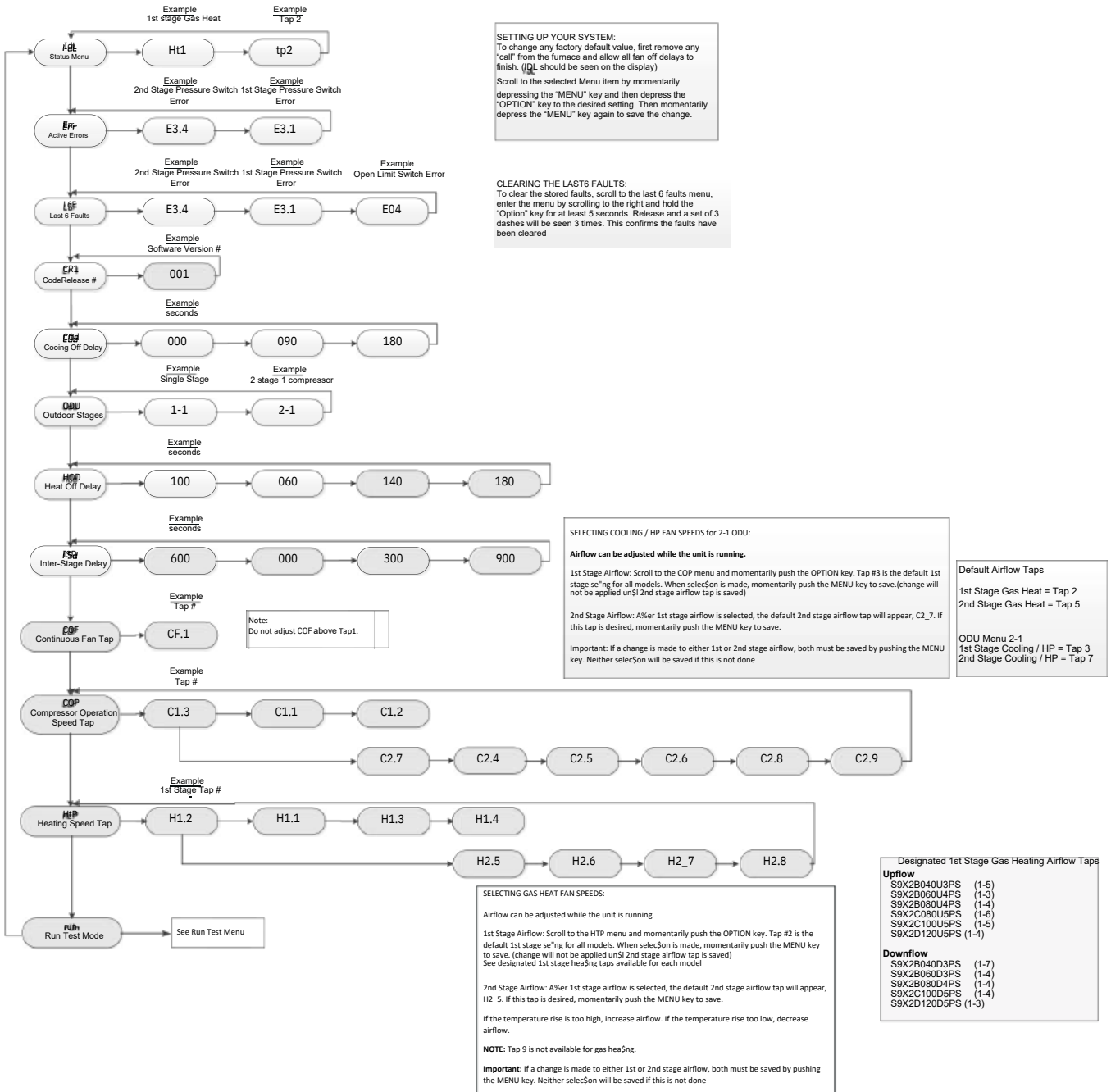

Figure 189. Control system menu two stage OD — S9X2



Integrated Furnace Control Menu

Figure 190. Run test mode and system status menu

S9X1 – S9X2 – S9B1 RunTest Mode

Run Test Mode:

To enter Run Test Mode, scroll to using the Menu key, then push the op!on key. The LED will flash three times, then begin the test.

To exit the test mode, momentarily push the Menu key, cycle power to the furnace, or make a valid thermostat call for capacity or fan.

Sequence of Run Test Mode

- Turns the inducer on in 1ststage for 30 seconds
- Turns on the inducer on 2ndstage for 30 seconds (N/A for S9B1/S9X1)
- Turns the igniter on for 10 seconds
- Turns the circulating blower on 1st stage compressor speed for 10 seconds
- Turns the circulating blower on 2nd stage compressor speed for 10 seconds (N/A for S9B1)
- Turns the circulating blower on 1ststage gas heat speed for 10 seconds
- Turns on the circulating blower on 2ndstage gas heat speed for 10 seconds (N/A for S9B1, S9X1)

The above sequence will repeat two more times unless the Run Test Mode is exited, see above

Important:The Run Test Mode does not test fire the furnace or bring the outdoor unit on. It is designed to allow the technician to observe each mode to ensure the IFC, inducer, and circulating blower are performing as intended.

S9X1 – S9X2 – S9B1 System Status Menu

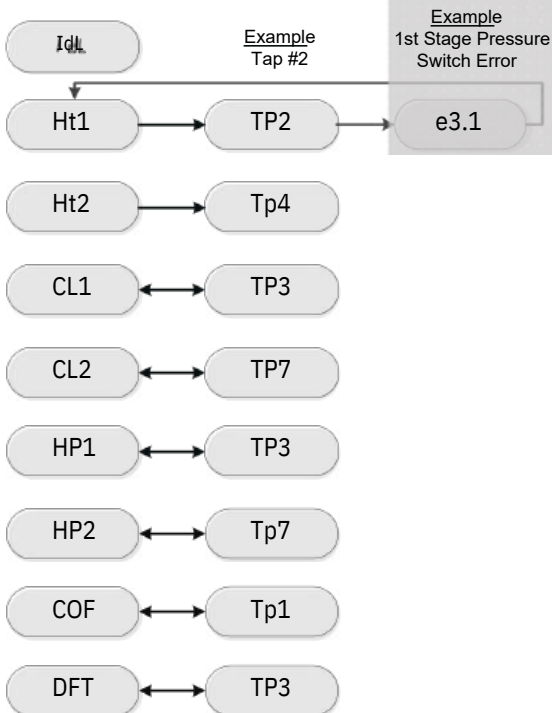

- IDL = Idle, no demand for cooling, heating, or fan
- HT1 = Demand for 1st stage gas heat (HT = S9X1 & S9B1)
- HT2 = Demand for 2nd gas heat
- CL1 = Demand for 1st stage cooling (CP1 = S9X1 & S9B1)
- CL2 = Demand for 2nd stage cooling (CP2 = S9X1)
- HP1 = Demand for 1st stage heat pump (GP1 = S9X1 & S9B1)
- HP2 = Demand for 2nd stage heat pump (GP2 = S9X1)
- COF = Demand for continuous fan
- DFT = Demand for outdoor unit defrost, furnace running in gas heat mode
- TP1-9 = Tap selected for airflow

NOTE:

- (1) The menu status displayed is solely dependent on the input of 24VAC that is applied to the low voltage terminal strip.
- (2) The status will alternate between the system mode and the airflow request every 2 seconds.
- (3) If an error occurs, an E*. * will alternately flash with the system mode and airflow request. See first example.

Setting Airflow

With all ductwork connected and a clean filter in place, measure the External Static Pressure (ESP) of the unit in locations below. Use the appropriate airflow table in the Airflow Tables section for the furnace and outdoor unit installed.

Measurements must be made prior to the evaporator coil, if equipped, and after the filter.

Notes:

- See Airflow Tables section in this document.
- Check out fieldtechhelp.com to watch a short video.

Figure 191. Setting airflow on the 9-tap motor



Figure 192. Setting airflow

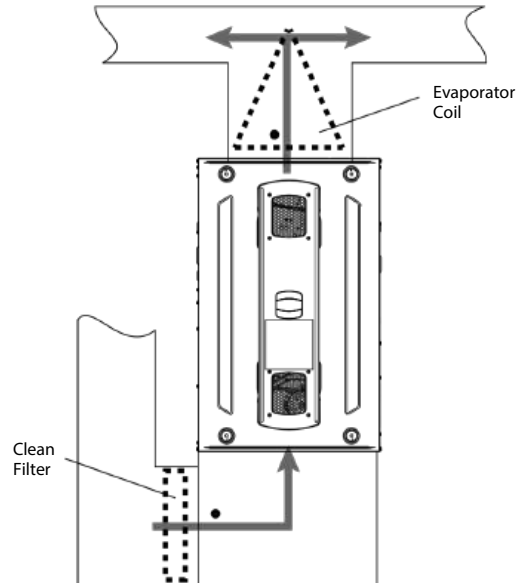

Table 41. Setting airflow table

S9X1/S9B1/S9X2 B080U4 Furnace Airflow (CFM) at. External Static Pressure (in. W.C.) versus Tap																
		Static														
		0.1			0.3			0.5			0.7			0.9		
Tap	Torque (%)															
1 20	SCFM/Watts 911/94 766/104	2 31	SCFM/Watts 1075/139	963/153	3 40	622 / 115	477 / 125	332 / 136								
	SCFM/Watts 1215/185 1121/202	4 43	SCFM/Watts 1250/203	164/221	5 51	851 / 168	740 / 182	628 / 197								
	SCFM/Watts 1349/251 1272/271	6 61	SCFM/Watts 1453/313	387/335	7 64	1028 / 219	934 / 236	840 / 253								
	SCFM/Watts 1505/340 1438/362	8 78	SCFM/Watts 1657/453	1597/477	9 100	1077 (a) / 239	990 / 257	903 / 274								
	SCFM/Watts 1878/669 1815/686					1194 / 291	1116 (b) / 310	1039 / 330								
						1321 / 356	1254 / 378	1188 / 400								
						1372 / 384	1305 / 406	1239 / 427								
						1538 / 500	1479 / 524	1419 (a) / 547								
						1752 / 702	1690 / 718	1627 / 735								

This is an example Airflow Table only. See "Airflow Tables," p. 32 for complete airflow data.

(a) Example 2
(b) Example 1

Example 1: S9X2B080U4PS (Default Tap 7)

Cooling / HP

- 3TonSingleStageOutdoor
- TotalESP=0.7"W.C.
- RequiredAirflow=1050cfm(3Tx350cfm/ton)
- NewTapNumber=Tap5(Re-checkstaticpressure and adjust airflow as necessary)

Example 2: S9X2B080U4PS (Default Tap 3 & 7)

- 4TonTwoStageOutdoor
- Total2ndStageESP=0.9"W.C.

- Total 1st Stage ESP = 0.6" W.C.
- Required 2nd Stage Airflow = 1400 cfm (4T x 350 cfm/ton)
- Required 1st Stage Airflow = 1050 cfm (2nd stage airflow x .75)
- New 2nd Stage Tap Number = Tap 8 (Re-check static pressure and adjust as necessary)
- New 1st Stage Tap Number = Tap 4 (Re-check static pressure and adjust as necessary)

Integrated Furnace Control Display Codes

Table 42. Menu options

Menu Options	
IdL	Idle
err	Active Alarm Errors
L6F	Last 6 Faults (To clear — Hold Option button down for 5 seconds after entering the L6F menu)
Cr	Code Release Number
C0d	Cooling Off Delay (Seconds)
Odu	Outdoor Unit Type
C0f	Blower Constant Fan Airflow
X0d	Heat Off Delay (Seconds)
ISD	Inter-Stage Delay (Seconds)
GHC	Gas Heating CFM (1st and 2nd stage airflow are selectable)
run	TestMode

Table 43. Error codes

Alarm Error Code	Alarm Explanation
e0!	Loss of the IRQ or other internal failures (Internal IFC error) Retry Exceeded (Flame
e2.!	never sensed, one hour lockout after 3 times) Recycles Exceeded (Flame sensed then
e2.2	lost, one hour lockout after 10 times) 1st Stage Gas Valve Not Energized When It Should
e2.3	Be exceeded after 10 times Shorted Pressure Switch, 1st Stage Open Pressure Switch,
e3.!	1st Stage Shorted Pressure Switch, 2nd Stage (Not applicable for S9X1/S9B1) Open
e3.2	Pressure Switch, 2nd Stage (Not applicable for S9X1/S9B1) Open Limit (Main Thermal,
e3.3	Rollout Switch, or Reverse Airflow Switch) Flame detected, should not be present
e3.4	Voltage reversed polarity Bad grounding (1) Igniter relay fails (2) Igniter open 1st Gas
e04	valve (MVL) is energized when it should be off Flame current is low, but still strong
e0s	enough to allow operation Open Inducer Limit Switch or Condensate Pressure Switch (1)
e6.!	1st stage gas valve not energized when it should be (2) 1st stage gas valve relay stuck
e6.2	closed (3) 2nd stage gas valve relay stuck closed (Not applicable for S9X1/S9B1) (4) 2nd
e6.3	stage gas valve energized when it should not be (Not applicable for S9X1/S9B1) (5) 2nd
	stage gas valve not energized when it should be (Not applicable for S9X1/S9B1)
e7.!	
e08	
e09	
e11	

Table 43. Error codes (continued)

Alarm Error Code	Alarm Explanation
e12	Open fuse
e14 / e18	Refer troubleshooting flow chart

Fault Code Recovery

Fault Code Recovery

- To view the last 6 faults, press the “Menu” key until the “Last 6 Faults” (L6F) menu appears.
- Enter the menu by pressing the “Option” key.
- The last 6 faults can be viewed.

Clearing the Last 6 Faults

- To clear the last 6 faults, press the “Menu” key until the “Last 6 Faults” (L6F) menu appears.
- Enter the menu by pressing the “Option” key.
- Hold the “Option” key for at least 5 seconds.
- Release and a set of 3 dashes will be seen 3 times.
This confirms the faults have been cleared.

Resetting Factory Defaults

- Display must be in Idle Mode.
- Push the “Menu” and “Option” buttons at the same time for 15 seconds then release.
- The 7 segment will flash “FD” 3 times. This confirms the unit has been reset to the factory defaults.

Note: The S9B1 does not have EAC or HUM connections.

Figure 194. S9X2 IFC component layout

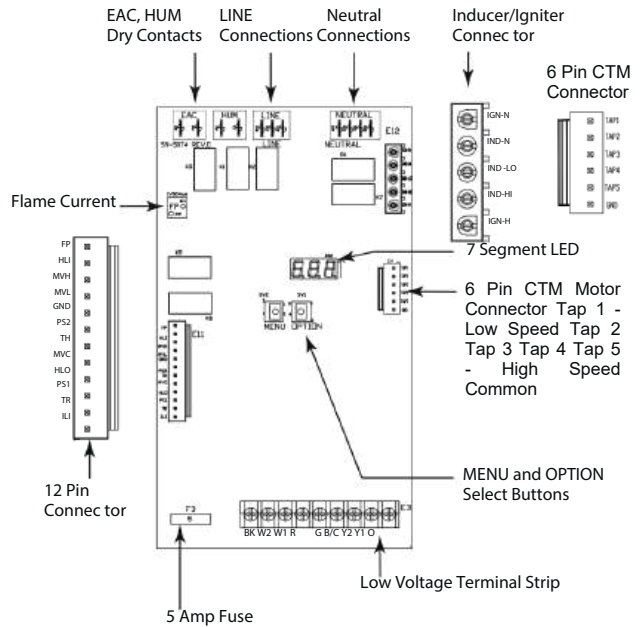
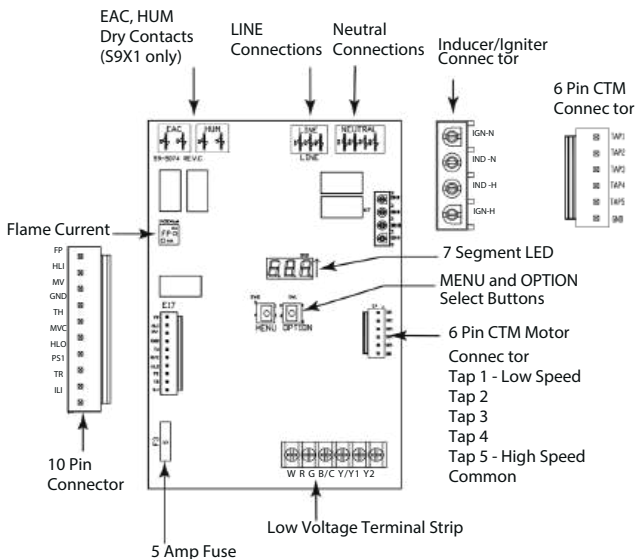

Figure 193. S9X1 and S9B1 IFC component layout



Troubleshooting

The following pages include troubleshooting flowcharts in reference to the S9X1 and S9B1 single stage furnaces and the S9X2 two stage furnace only.

The information contained is for reference only and does not cover all scenarios or problems that may be encountered.

Only qualified technicians should attempt to install, troubleshoot, or repair this appliance.

Failure to follow all cautions and/or warnings could result in personal or property damage, including death.

Figure 195.

S9X1 and S9B1 IFC component layout

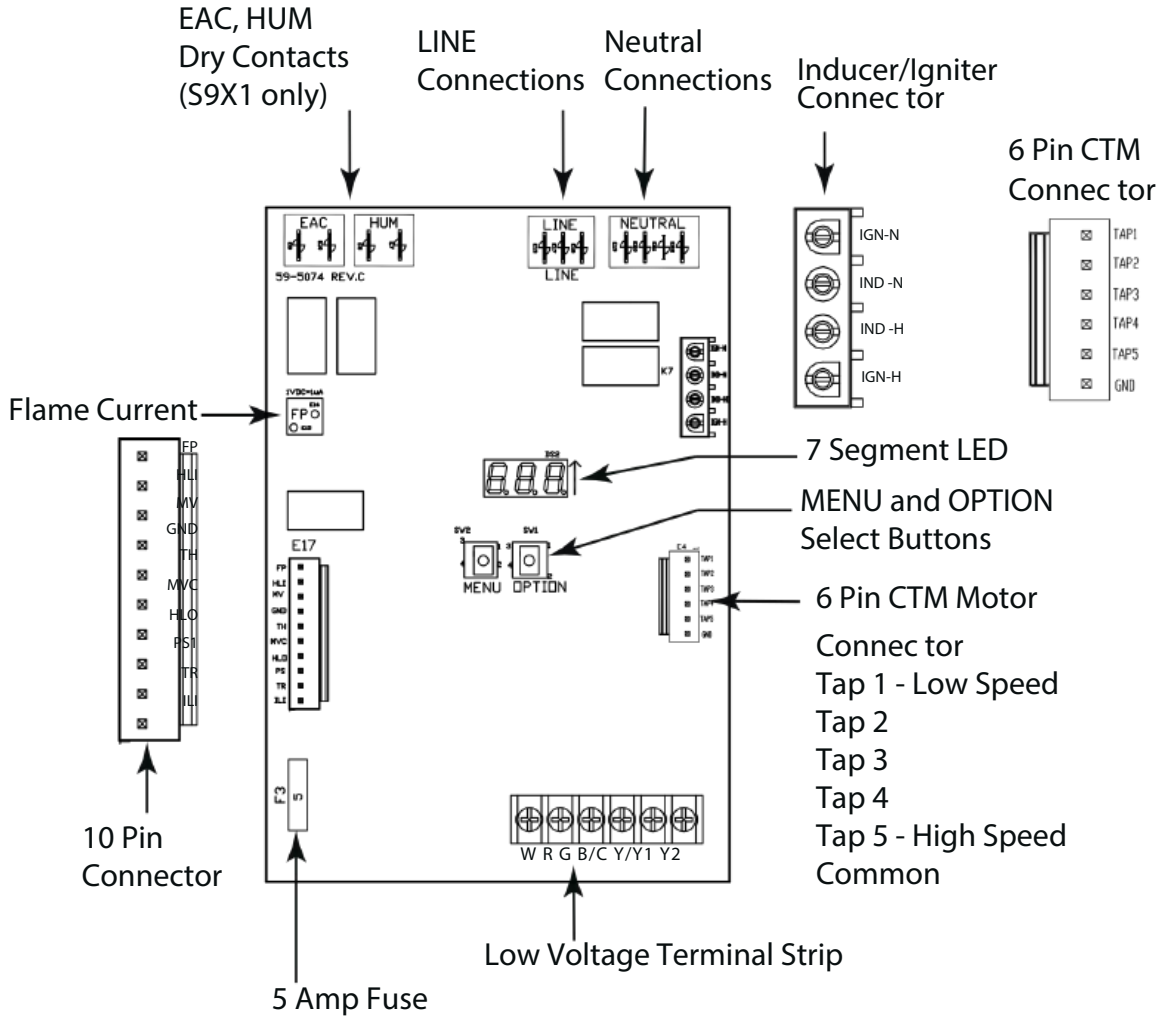

Note: The S9B1 does not have EAC or HUM connections.

Figure 196. S9X2 IFC component layout

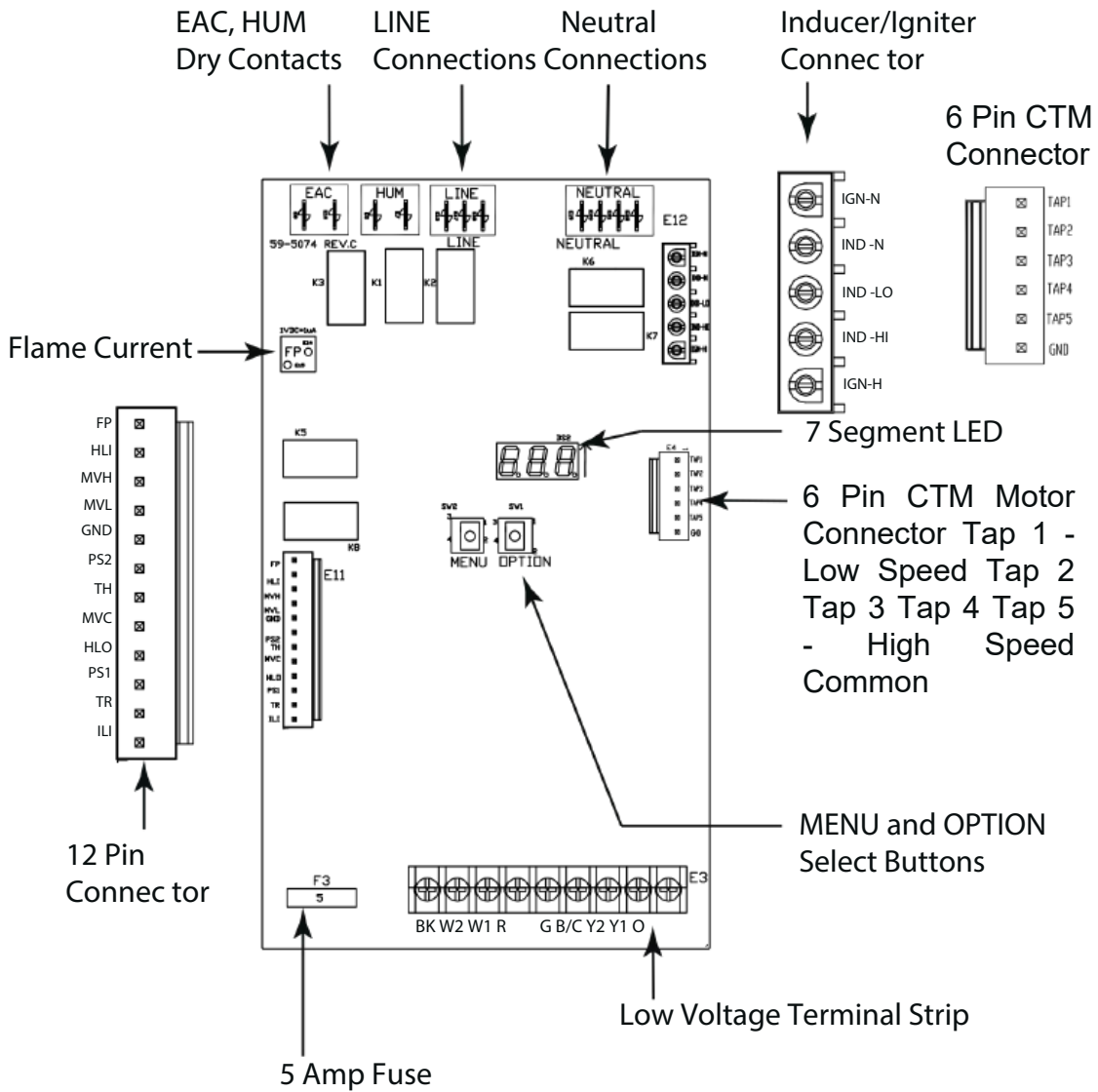

GETTING STARTED

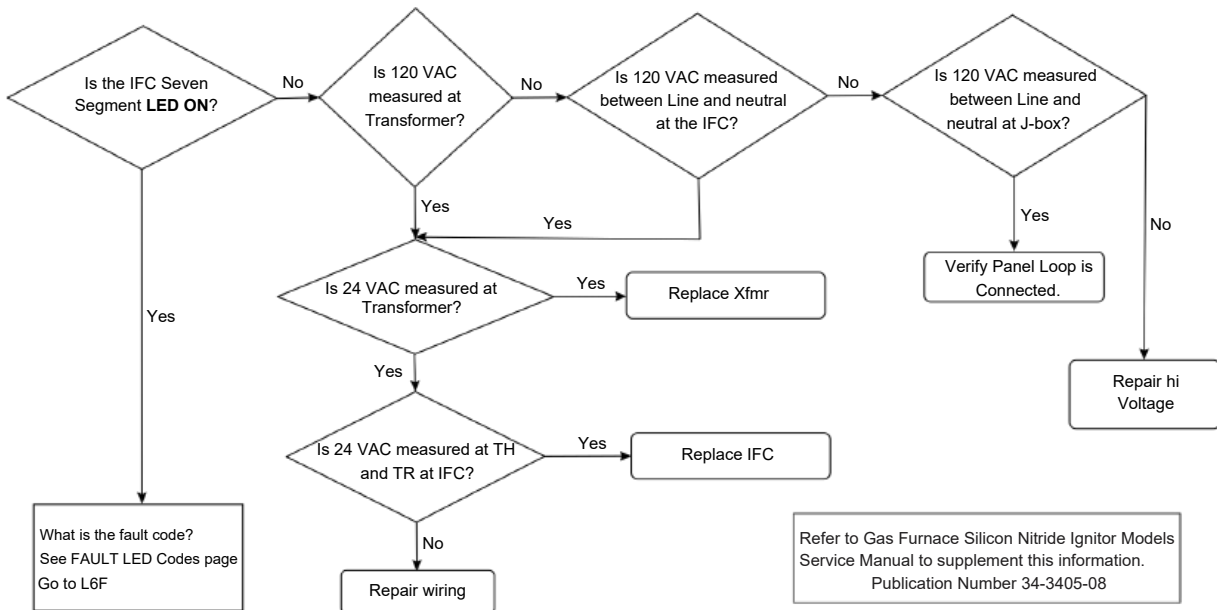

01 Fault Code → **Replace IFC**

DEFINITION:
Internal Failure of the Control Board.

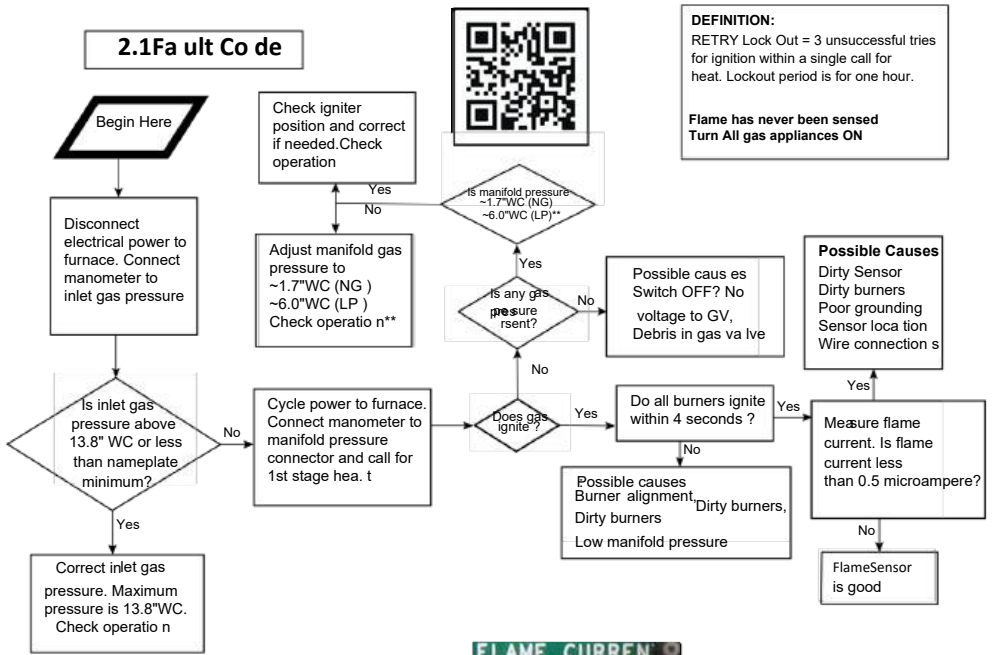

There are two flame sense pads located on the IFC, marked "FP". To measure flame current, use a VOM set to DC volts. Flame current will vary depending on the type of meter used. Typical flame current ranges from 0.75 – 3.0 micro-amps (0.75 – 3.0 VDC)

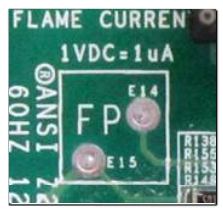

** S9X1/S9B1 manifold pressure
~3.5"WC (NG)
~10.0"WC (LP)

2.2F ault Co de



DEFINITION
 RECYCLE Lock Out = 10 recycles within a single call for heat. Lockout period is for one hour.
Flame has never been sensed
Turn All gas appliances ON

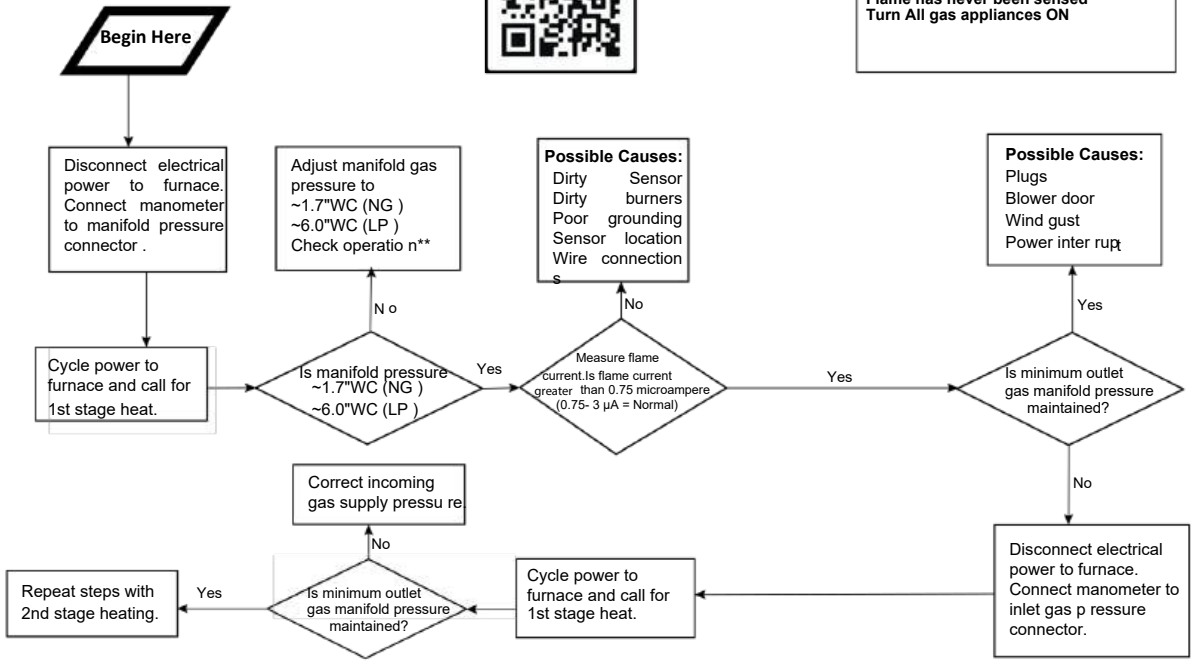

There are two flame sense pads located on the IFC, marked "FP". To measure flame current, use a VOM set to DC volts. Flame current will vary depending on the type of meter used. Typical flame current ranges from 0.75 – 3.0 micro-amps (0.75 – 3.0 VDC).



S9X1/S9B1 manifold pressure
 ~3.5"WC (NG)
 ~10.0"WC (LP)

2.3F ault Co de

Replace IFC

DEFINITION:
 1st Stage Gas Valve not energized when it should be 10 times within the same call for heat.
24VAC not sensed on MVL 10 TIMES

3.1 Fault Co de



DEFINITION:
 An error has occurred with the PS1, indicating that the pressure switch is closed when it should be open.
In most cases, the pressure switch is not the problem.
NOTE: Verify pressure switch wiring and tube routing are correct.

Note #1
 OL = Open Switch
 0 ohms = Closed Switch

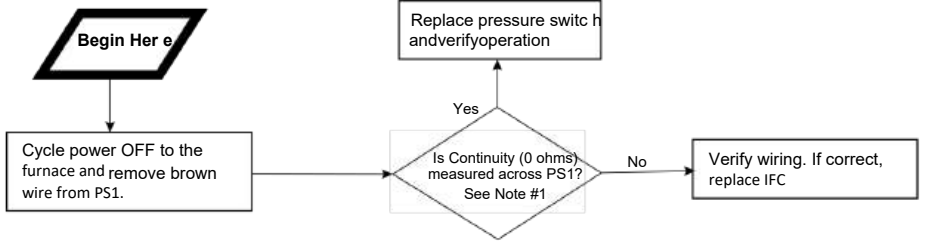

Troubleshooting

3.2 Fault Code



Note #1

24 volts = Open Switch
0 volts = Closed Switch

Note #2

Measured pressure is negative, greater than refers to magnitude only

DEFINITION:

An error has occurred with the PS1 indicating that the pressure switch is open when it should be closed.

In most cases, the pressure switch is not the problem.

NOTE: Verify pressure switch wiring and tube routing are correct.

PS 1 Open errors can occasionally happen when wind gusts occur.

S9X2 Only

The IFC will attempt to close both PS1 and PS2 and operate on 2nd stage during such an event.

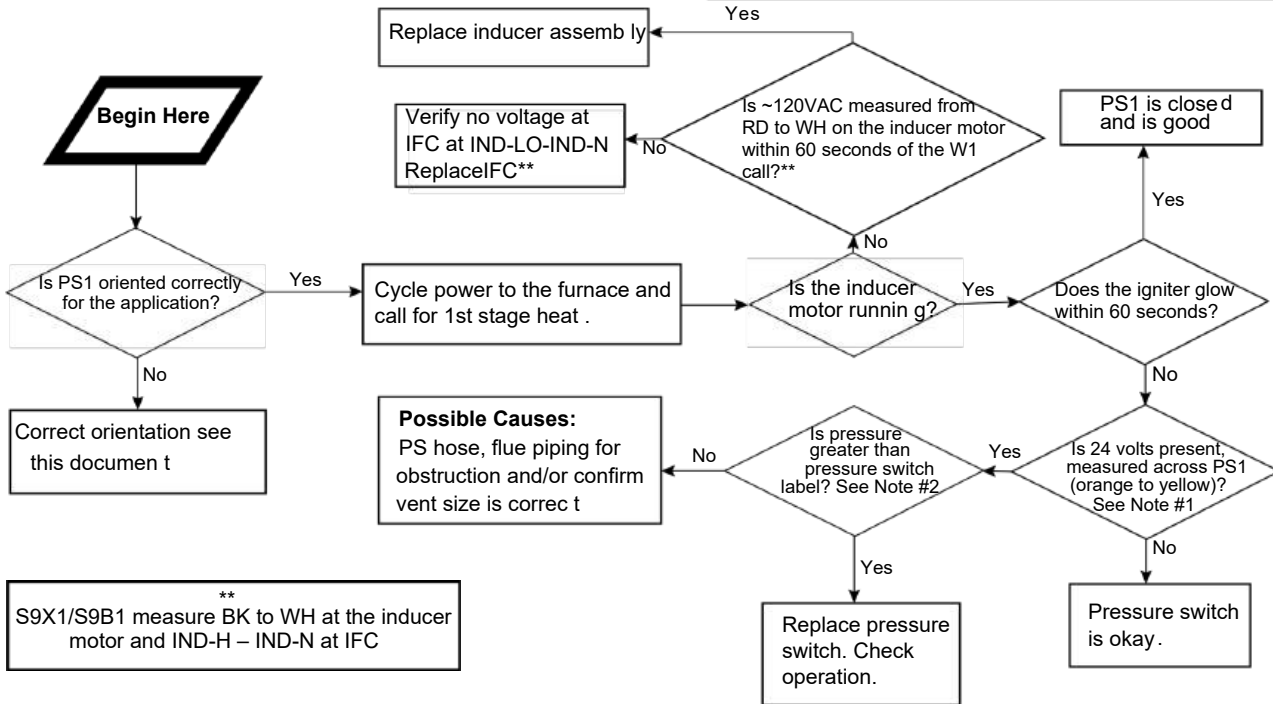

3.3 Fault Code



Note #1

OL = Open Switch
0 ohms = Closed

DEFINITION:

An error has occurred with the PS2, indicating that the pressure switch is closed when it should be open.

In most cases, the pressure switch is not the problem.

NOTE: Verify pressure switch wiring and tube routing are correct.

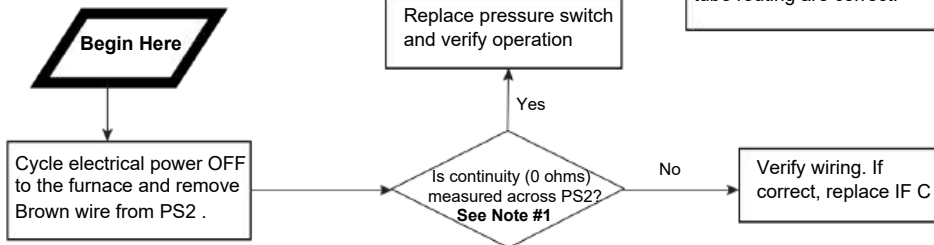

3.4Fault Code



DEFINITION:

An error has occurred with the PS2 indicating that the pressure switch is open when it should be closed .

In most cases, the pressure switch is not the problem.

Note: Verify pressure switch wiring and tube routing are correct.

Note #1

24 volts = Open Switch
0 volts = Closed Switch

Note #2

Measured pressure is negative, greater than refers to magnitude only.

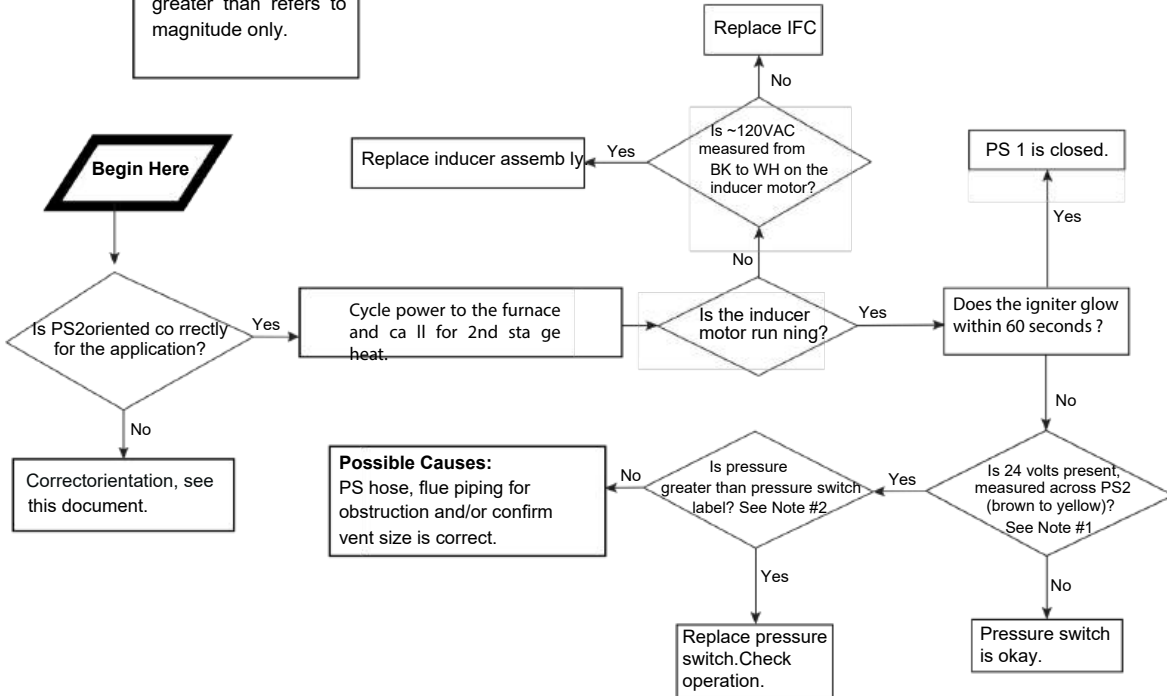



DEFINITION:
 Limit switches are safety devices that will open when an abnormal high temperature has been sensed. REMOVE ALL JUMPER WIRING TO SWITCHES!
 Under no circumstances, shall these switches be left jumpered when not troubleshooting. Verify filters and blower wheels are clean.

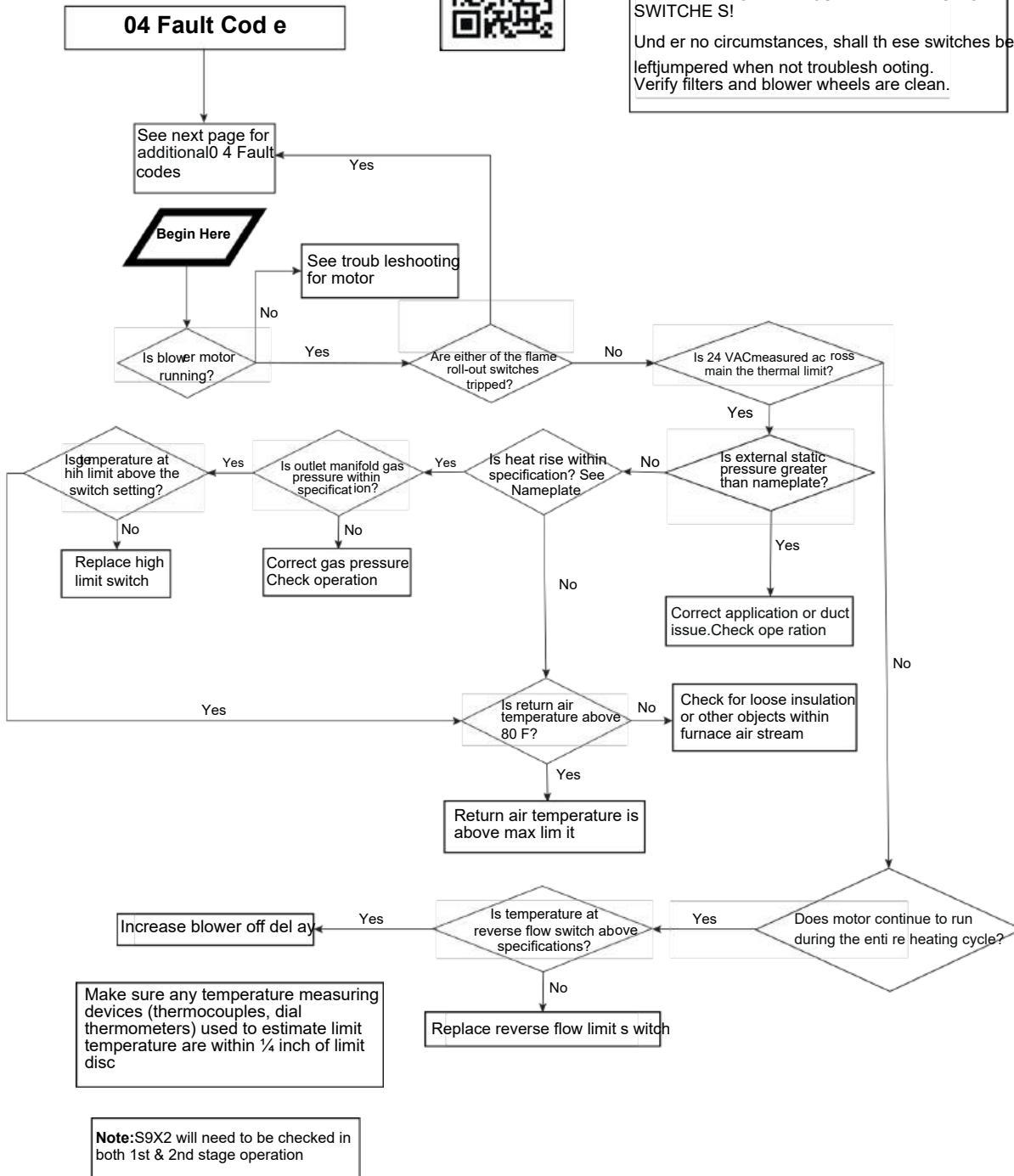

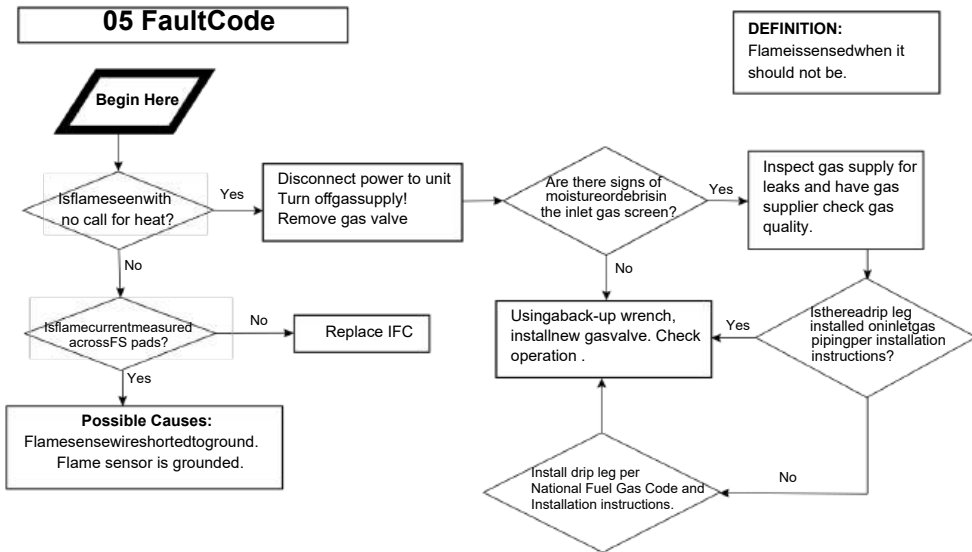
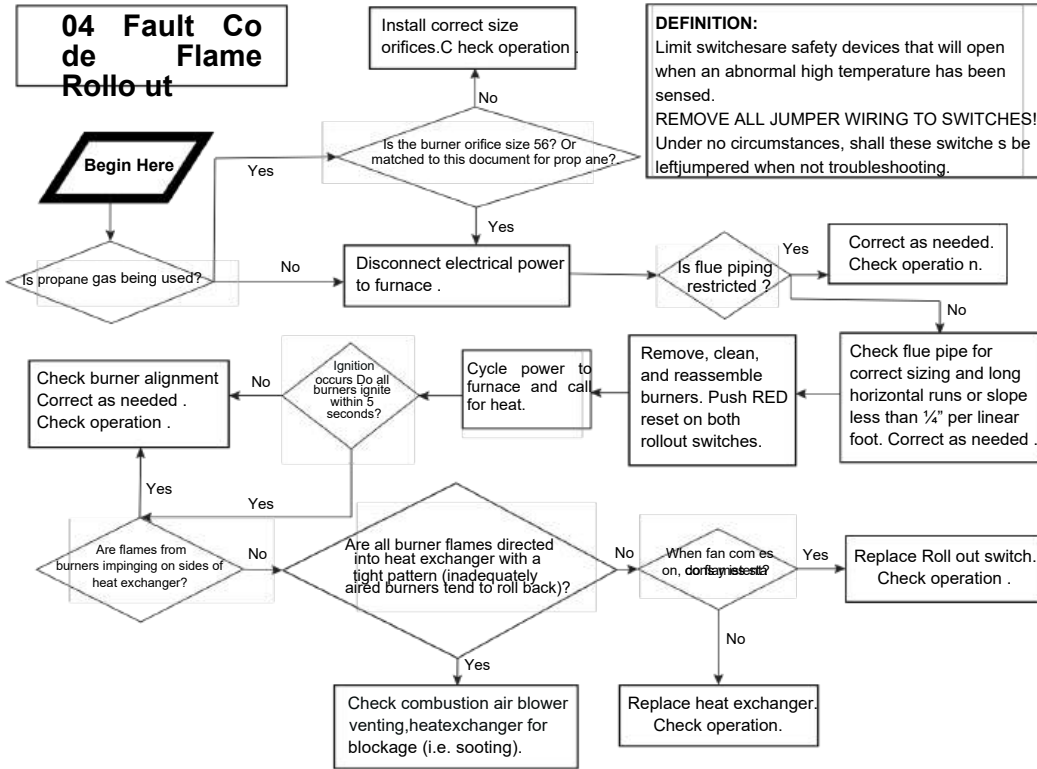

There are two flame sense pads located on the IFC, marked "FP". To measure flame current, use a VOM set to DC volts. Flame current will vary depending on the type of meter used. Typical flame current ranges from 0.75 – 3.0 micro-amps (0.75 – 3.0 VDC).



6.1F ault Code



DEFINITION:
Polarity Fault-Incoming high voltage wiring is reverse d.

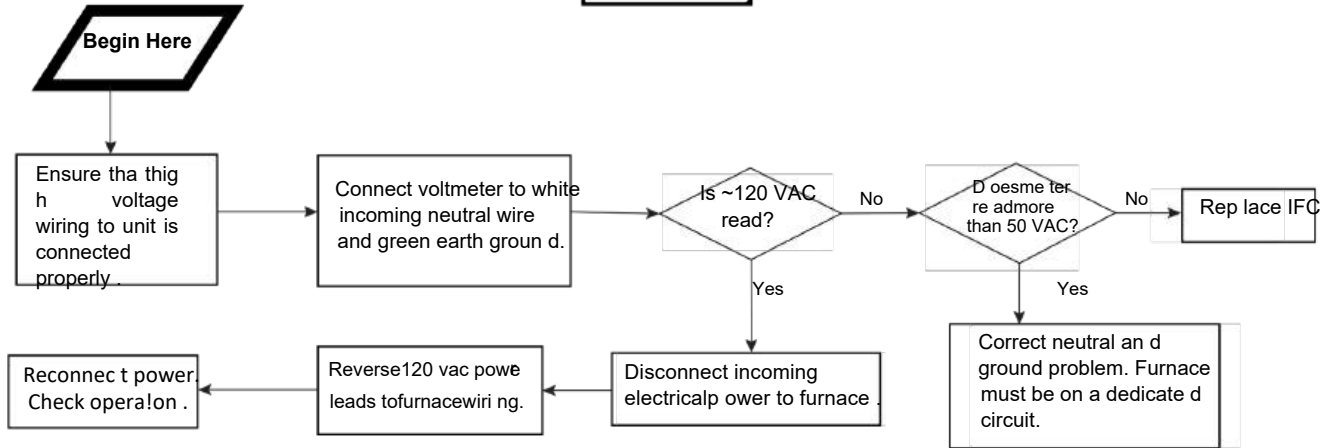

6.2Fa ult Code

DEFINITION:
Ground Fault-Incoming chassis ground connection is not sensed

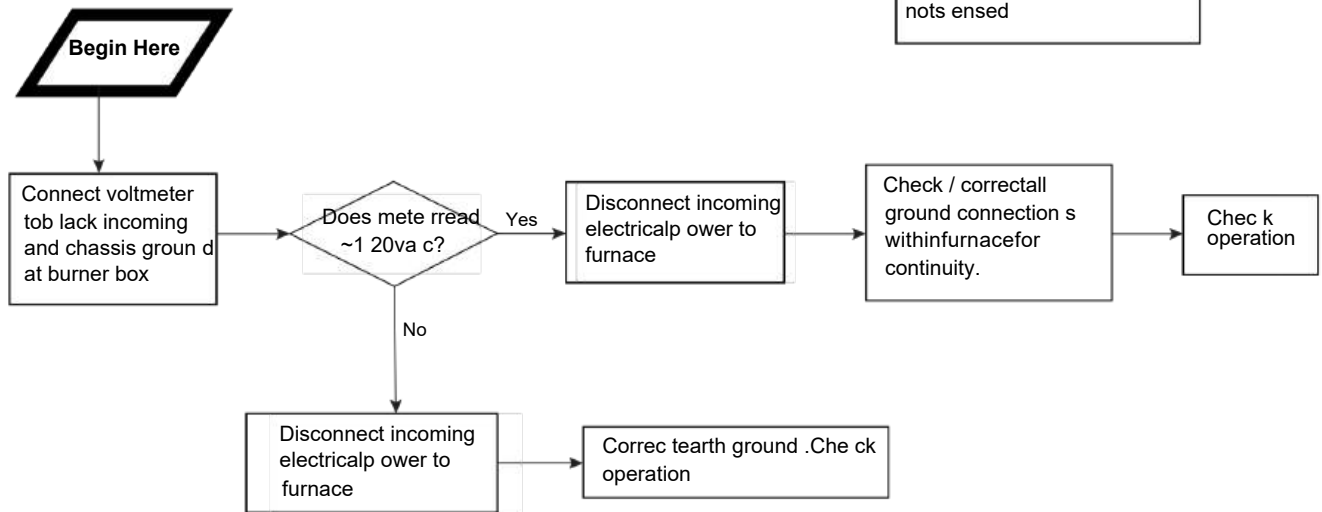

6.3F au ItC ode

DEFINITION:

IgniterRelayFault –The control board has sensed thatthe igniter relay has stuc k closed

Ignitor Fault – The control board has sensed that the ignitor circuit is open or shorted .

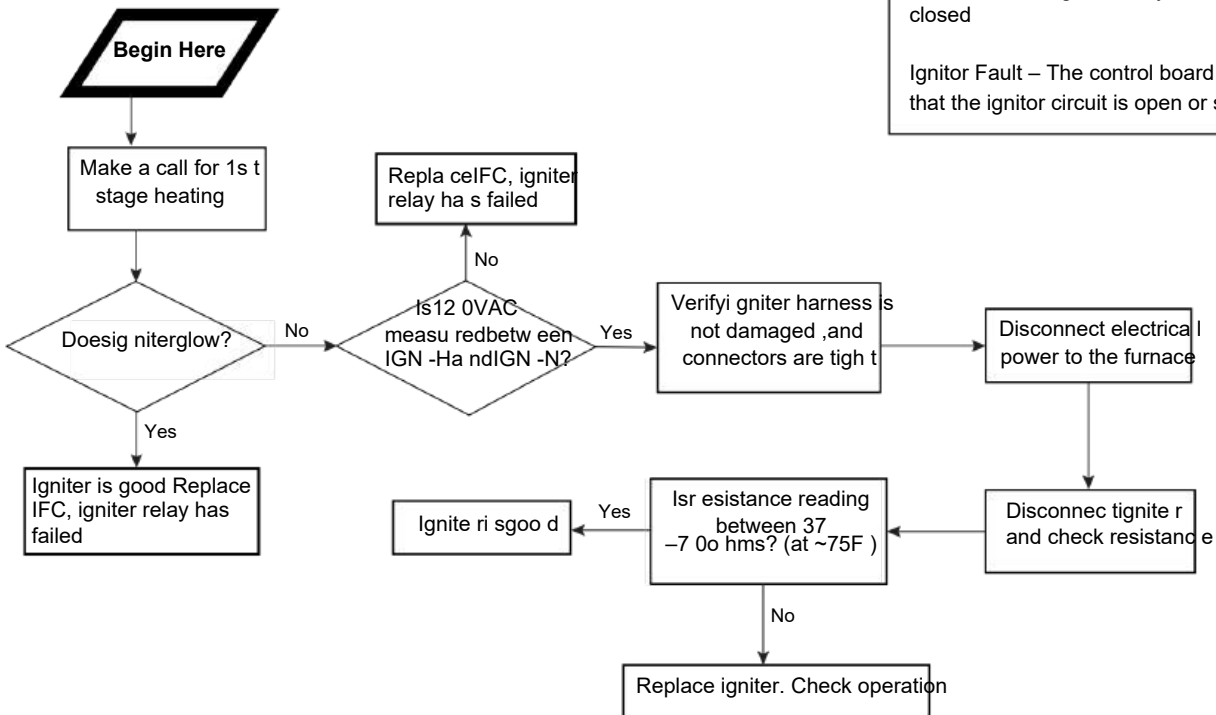

7.1F au ItC ode

DEFINITION:

ExternalGasValve Circuit Error (24 volts present when it should not be present)

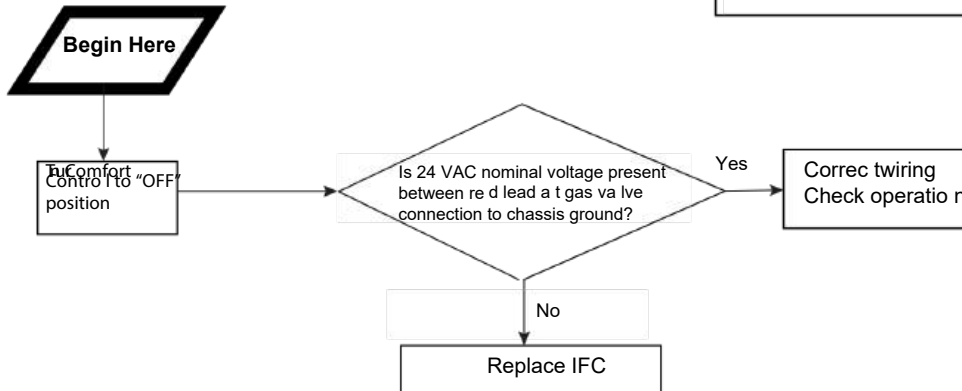

8Fau ItC ode

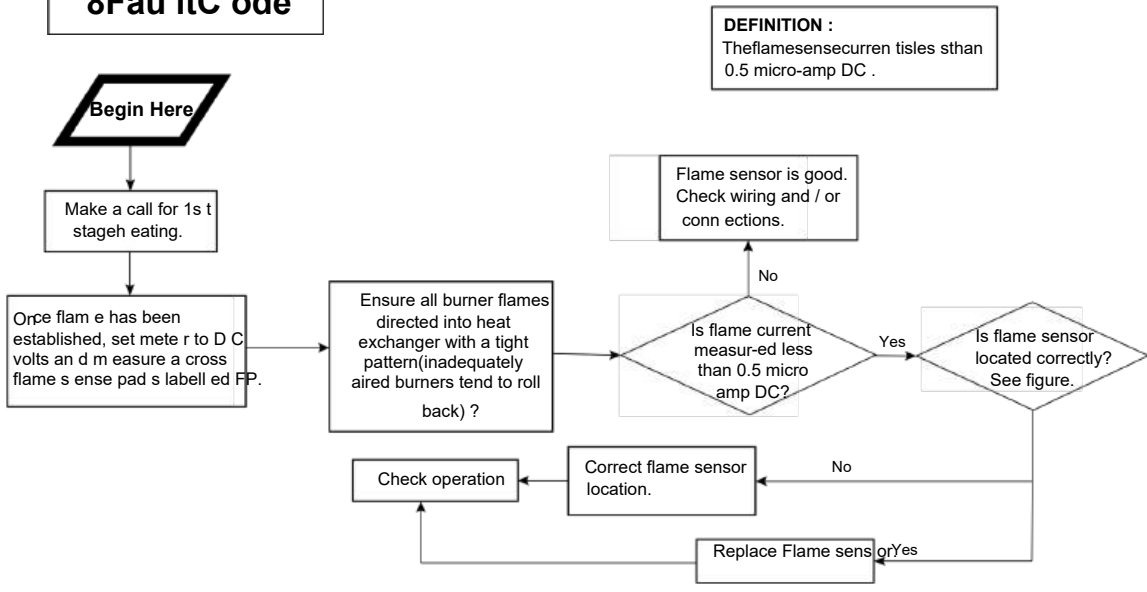

DEFINITION :
The flamesense current is less than 0.5 micro-amp DC .

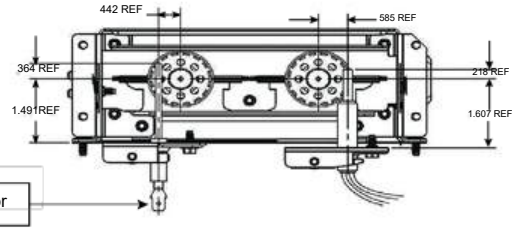

There are two flame sense pads located on the IFC, marked "FP". To measure flame current, use a VOM set to DC volts. Flame current will vary depending on the type of meter used. Typical flame current ranges from 0.75 – 3.0 micro-amps (0.75 – 3.0 VDC).

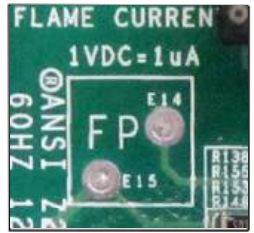

9 Fault Code



DEFINITION:
 Condensate Pressure Switch Open: The condensate system is not free flowing and opened the safety switch O R.
 Inducer Limit: This error is normally caused by improper installation or application of the furnace venting system.

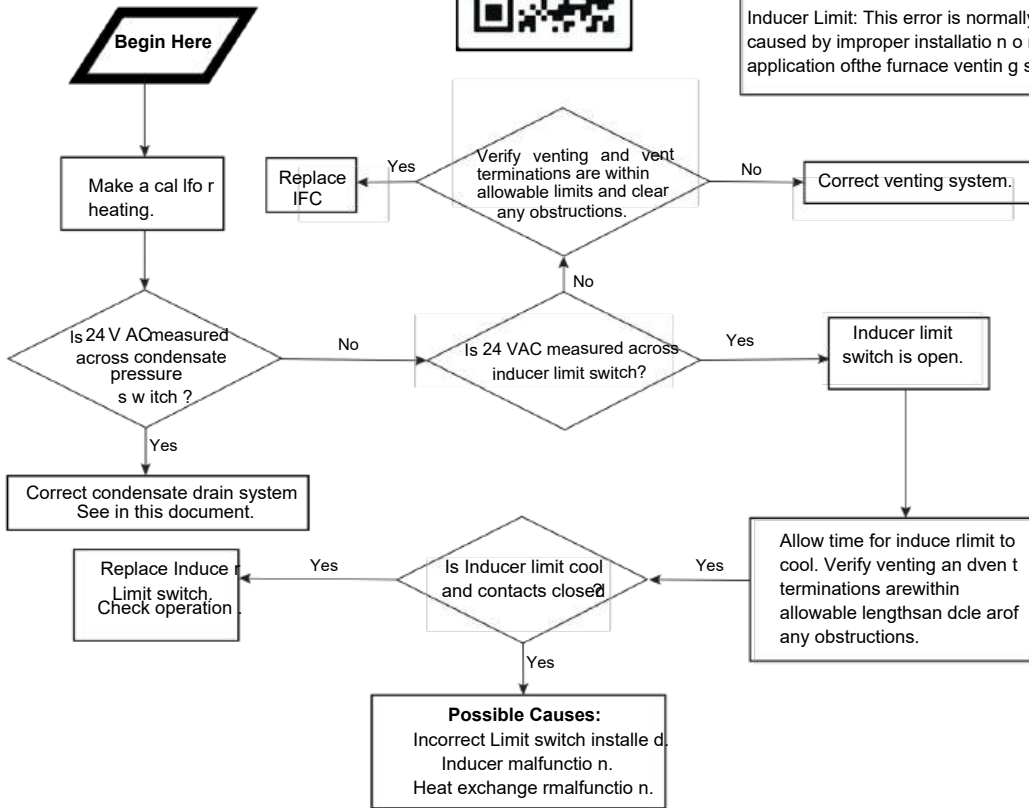

DEFINITION:
 The FCHAS detected that internal gas valve relay has failed

11 Fault Code

Verify all wiring
 Replace IFC

12 Fault Code

DEFINITION:
The onboard 5amp fuse is open or missing .

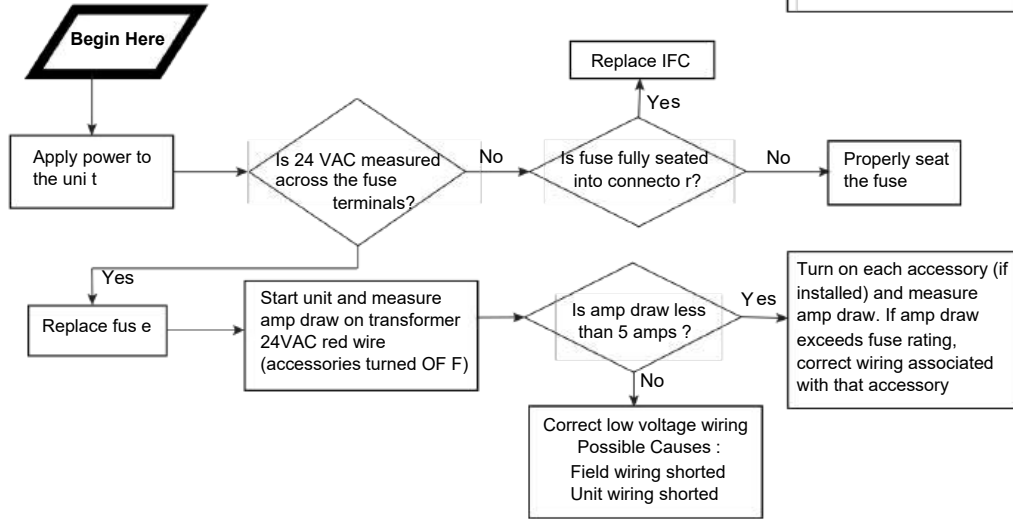

E14/E18 Fault Code

DEFINITION :
These errors have been reported in association with the S9X2 model furnaces on initial start-up. They are not valid errors but can typically be corrected by following the flow chart.

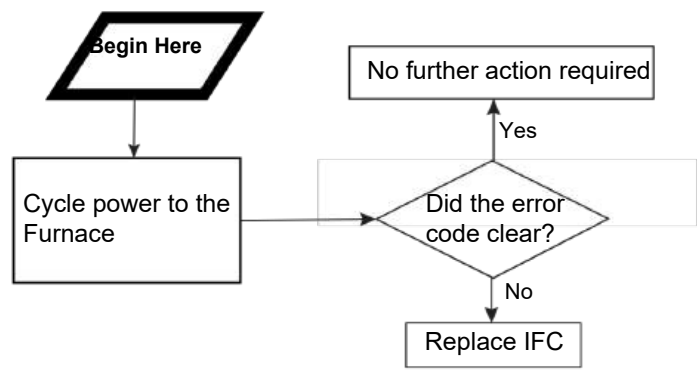

Constant Torque Motor Troubleshooting

Continuous FAN on this unit is limited to TAP 1 only. No field adjustment can be made. If troubleshooting other speed taps, use the method as outlined below using the voltages listed for the tap number being used.

Begin Here

Ensure power is applied to the unit and Seven Segment LED's are ON with no active error codes → Turn fan to ON at thermostat and verify that COF and TP1 alternately appear on the seven segment display

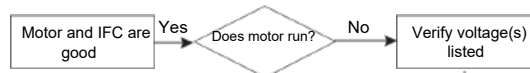

If voltage is not present, remove 6 pin connector from IFC and re-check. If voltage is present, verify voltage at panel connectors and at motor. If voltage is present at the motor, replace motor

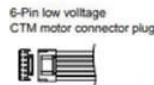

1. Remove the 6-pin low voltage connector from the IFC
2. Apply 24 VAC to Common tap (Blue) and any speed tap on the CTM motor 6-pin plug. The motor should run.

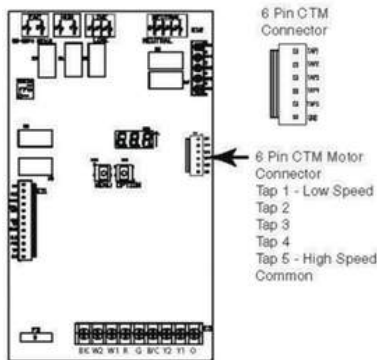
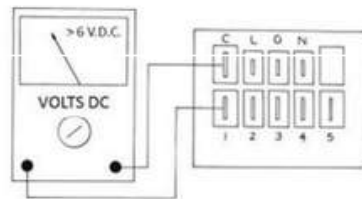
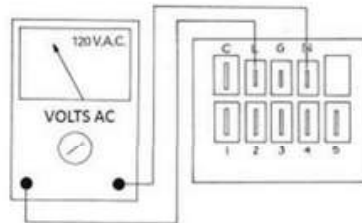

S9X1 / S9B1 / S9X2 Output Voltage

RD/W	Tap 1
YL/W	Tap 2
BL/W	Tap 3
BK/W	Tap 4
OR/W	Tap 5
BLUE	24v C

Tap 1	~ 8vdc	
Tap 2	~ 8vdc	
Tap 3	~ 18vdc	
Tap 4	~ 8vdc	
Tap 5	~ 18vdc	
Tap 6 (1+2)	~ 8vdc	~ 8vdc
Tap 7 (1+3)	~ 8vdc	~ 18vdc
Tap 8 (1+4)	~ 8vdc	~ 8vdc
Tap 9 (1+5)	~ 8vdc	~ 18vdc

All Voltages Reference Ground

Belly Band Location

Distance from belly band to the back side off motor for minimum vibration.

Figure 197. Belly band location

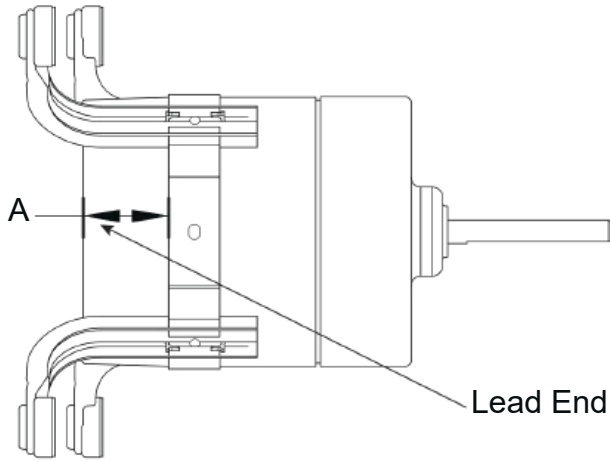

Blower housings and wheel removed from view for clarity.

Table 44. Belly band location

Furnace Model Number	Dimension "A" (inches)
S9B1B060U4PSAB S9X1B060U4PSBB S9X2B060U4PSBB S9B1B080U4PSAB S9X1B080U4PSBB S9X2B080U4PSBB	2.65
S9B1C080U5PSAB S9X1C080U5PSBB S9X2C080U5PSBB S9B1D120U5PSAB S9X1D120U5PSBB S9X2D120U5PSBB S9B1B080D4PSAB S9X1B080D4PSBB S9X2B080D4PSBB S9B1C100D5PSAB S9X1C100D5PSBB S9X2C100D5PSBB S9B1D120D5PSAB S9X1D120D5PSBB S9X2D120D5PSBB	3.54
S9B1C100U5PSAB S9X1C100U5PSBB S9X2C100U5PSBB	3.81
S9B1B040U3PSAB S9X1B040U3PSBB S9X2B040U3PSBB S9B1B040D3PSAB S9X1B040D3PSBB S9X2B040D3PSBB S9B1B060D3PSAB S9X1B060D3PSBB S9X2B060D3PSBB	3.91

Sequence of Operation

Note: The seven segment LED readout is based solely on thermostat input. During a simultaneous call for W1 and W2, the seven-segment will read Xt2, although the IFC will process the call for 1st stage heat first.

1st Stage Gas Heating

1. R – W contacts close on the thermostat sending 24VAC to the W1 low voltage terminal of the IFC. Technician should read 24VAC from W to B/C. The seven-segment LED will read:

Xt1 = 1st Stage gas heat (S9X2)

Xt = Gas Heat (S9X1, S9B1)

2. The IFC performs a self-check routine and then confirms that the:
 - a. Condensate pressure switch and Inducer limit switch are closed by sending 24VAC out the HLO terminal and monitoring the ILI input.
 - b. Flame roll-out switches (FRS) 1 and 2, main thermal limit (TCO), and any reverse air flow (RAF) switches are closed by sending 24VAC out the HLO terminal and monitoring the HLI input.
 - c. Pressure switch 1 (PS1) and pressure switch 2 (PS2 – S9X2 only) are open by sending 24VAC out the HLO terminal, through the limit switches, and monitoring the PS1 and PS2 inputs.

Note: If a thermal limit is open, 24VAC will not be present at the pressure switch.

3. After steps a, b, and c are confirmed, the inducer relay is closed energizing the inducer motor.
4. As the inducer ramps up, PS1 will close.
5. When PS1 closes, the ignitor relay on the IFC will close. The ignitor is energized. The ignitor warm up is approximately 17 seconds.
6. After the ignitor warm up, the gas valve relay is closed on the IFC, which energizes the gas valve solenoid to allow ignition.
7. The first burner will ignite, and flame will crossover to the remaining burners, establishing current to the flame sensor. Proof of flame must be established within 4 seconds.

Note: There are two flame sense pads located on the IFC marked as “FP”. To measure the flame current, use a VOM set to DC volts. 1VDC = 1 micro-amp. Flame current will vary depending on the type of meter used. Typical flame current ranges from 0.75 – 3.0 micro-amps (0.75 – 3 VDC).

8. Once flame sense has been established, a timer on the IFC starts, and the indoor blower will energize at 1st stage speed after the blower “Heat On Delay” has completed. The seven-segment LED for example will alternately read:

Xt = Gas heating = S9X1 / S9B1

Xt1 = Gas heating, Stage 1 = S9X2
TP2 = Speed Tap 2

9. When the temperature raises enough to satisfy the thermostat setting, contacts R-W will open.
10. The gas valve relay will open, closing the gas valve. The inducer will continue to run for approximately 5 seconds to remove any combustion by-products from inside the furnace.
11. The indoor blower continues to run to remove heat from the heat exchangers. The blower off time is field adjustable through the IFC menu setup option. The seven segment LED will read IDL = Idle, no thermostat demand.

2nd Stage Gas Heating (S9X2 Only)

1. See sequence of operation for 1st stage gas heating operation above (steps 1-8)

Note: 2nd stage heating cannot operate without 1st stage operating.

2. R-W2 contacts close on the thermostat sending 24VAC to the W2 low voltage terminal of the IFC. Technician should read 24VAC from W2 to B/C. The seven-segment LED will read Xt2
3. The IFC checks to ensure that PS2 is open, and then energizes the 2nd stage inducer relay. The inducer is energized on high speed, and the second stage gas valve relay on the IFC closes, energizing second stage gas valve. The indoor blower motor will ramp up to the 2nd stage gas heating speed. The seven-segment LED for example will alternately read:

Xt2 = Gas heating, Stage 2

TP = Tap 5

4. The IFC monitors PS2 for closure and if PS2 does not close within 45 seconds, a PS2 open error will be declared and the furnace will operate in 1st stage. If PS2 closes, 2nd stage gas heating will continue until the thermostat R-W2 contacts open.

Note: If PS2 does not close within the 45 second time, the IFC will wait 10 minutes and repeat steps 3 and 4. If on the third attempt during the same heating call, PS2 does not close within the 45 second proving time, the unit will run in 1st stage until the thermostat contacts R-W2 open.

5. When the temperature raises enough to satisfy the thermostat setting, contacts R-W2 will open, the 2nd stage gas valve will close, the indoor blower motor will ramp down to 1st stage, and the unit will continue to run until R-W1 contacts open.
6. When the temperature raises enough to satisfy the thermostat setting, contacts R-W1 will open.
7. The gas valve relay will open, closing the gas valve. The inducer will continue to run for approximately 5