

Submittal

Upflow/ Horizontal Left/Right Two Stage Condensing Gas Fired Furnace 60,000 BTUH

Upflow, Convertible to
Horizontal Right or
Horizontal Left
S9X2B060U4PSBB

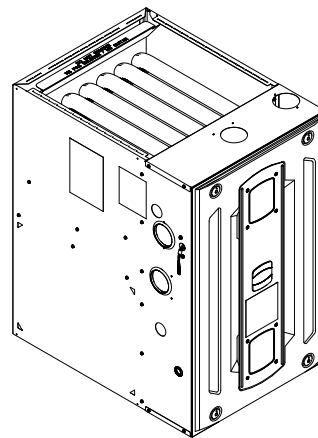

Note: Graphics in this document are for representation only. Actual model may differ in appearance.

⚠ WARNING

FIRE HAZARD!

Failure to follow this Warning could result in property damage, severe personal injury, or death.

This Warning applies to installations with a flammable refrigeration system.

The furnace must be powered except for service. The furnace shall be installed and connected according to installation instructions and wiring diagrams that are provided with the evaporator coil.

⚠ CAUTION

COIL REQUIREMENT!

Failure to follow this Caution could result in property damage or personal injury. *GXC* and *MXC* coils installed on upflow furnaces in vertical, horizontal left, or horizontal right orientations without a factory installed metal drain pan shield must use a MAY*FERCOLKITAA kit. Coils installed on upflow furnaces must have drain pans that are suitable for 400° F (205°C) or have a metal drain pan shield. Downflow furnaces do not require a metal drain pan shield or the use of the MAY*FERCOLKITAA kit. See Installer's Guide for more information.

Product Specifications

MODEL	S9X2B060U4PSBB (a)
TYPE	Upflow/Horizontal
RATINGS (b)	
1st Stage Input BTUH (ICS)	39,000
1st Stage Capacity BTUH	37,830
2nd Stage Input BTUH	60,000
2nd Stage Capacity BTUH (ICS) (c) (d)	58,200
1st Stage Temp. Rise (Min.-Max.)	25 - 55
2nd Stage Temp. Rise (Min.-Max.)	30 - 60
AFUE (%)	96.0
Return Air Temp. (Min. - Max.)	45°F - 80°F
BLOWER DRIVE	DIRECT
Diameter — Width (In.)	11 X 8
No. Used	1
Speeds (No.) (e)	9
CFM vs. in. w.g.	See Fan Performance Table
Motor HP	3/4
RPM	1075
Volts/Ph/Hz	120 / 1 / 60
FLA	8.4
COMBUSTION FAN — Type	Centrifugal
Drive — No. Speeds	Direct - 2
Motor HP — RPM	3300/2600
Volts/Ph/Hz	120 / 1 / 60
FLA	0.66
FILTER — Furnished?	No
Type recommended	High Velocity
Hi Vel. (No.-Size-Thk.)	1 - 16 X 25 - 1 in.
VENT PIPE DIAMETER — Min (in.) (f) (g)	2 Round
HEAT EXCHANGER	

MODEL	S9X2B060U4PSBB (a)
Type — Fired	409 Stainless Steel
— Unfired	29-4C Stainless Steel
Gauge (Fired)	20
ORIFICES — Main	
Nat. Gas Qty. — Drill Size	3 - 45
Propane Gas Qty. — Drill Size	3 - 56
GAS VALVE	Redundant - Two Stage
PILOT SAFETY DEVICE	
Type	120 V SiNi Igniter
BURNERS — Type	Multiport Inshot
Number	3
POWER CONN. — V/Ph/Hz (h)	120 / 1 / 60
Ampacity (In Amps)	11.3
Max. Overcurrent Protection (Amps)	15
PIPE CONN. SIZE (in.)	1/2
DIMENSIONS	H x W x D
Uncrated (In.)	34 x 17-1/2 x 28-3/4
Crated (In.)	35-1/2 x 19-1/2 x 30-7/8
WEIGHT	
Shipping (Lbs.)/Net (Lbs.)	130/122

(a) Meets Energy Star

(b) For U.S. applications, above input ratings (BTUH) are up to 2,000 feet, derate 4% per 1,000 feet for elevations above 2,000 feet above sea level. For Canadian applications, above input ratings (BTUH) are up to 4,500 feet, derate 4% per 1,000 feet for elevations above 4,500 feet above sea level.

(c) Central Furnace heating designs are certified to ANSI Z21.47 / CSA 2.3 — latest edition.

(d) Based on U.S. government standard tests.

(e) 9 Speed constant torque ECM blower motor

(f) Refer to the Vent Length Table in the Installer's Guide.

(g) All S9X2 furnace models have a vent outlet diameter that equals 2 in.

(h) The above wiring specifications are in accordance with National Electrical Code; however, installations must comply with local codes.

Airflow tables

Furnace Airflow (CFM) Vs. External Static Pressure (in. W.C.)							
Model	Tap		0.1	0.3	0.5	0.7	0.9
S9X2B060U4PSBB	1	SCFM	840	702	565	427	290
		Watts	91	101	111	121	130
	2	SCFM	1001	893	786	678	571
		Watts	137	149	162	174	186
	3	SCFM	1140	1051	963	875	786
		Watts	193	207	221	235	249
	4	SCFM	1208	1128	1048	969	889
		Watts	223	238	253	268	283
	5	SCFM	1299	1224	1148	1073	998
		Watts	270	284	298	312	327
	6	SCFM	1413	1348	1283	1217	1152
		Watts	343	359	375	391	406
	7	SCFM	1444	1380	1315	1251	1186
		Watts	354	370	386	403	419
	8	SCFM	1727	1674	1622	1570	1518
		Watts	612	631	650	668	687
	9	SCFM	1790	1741	1691	1642	1593
		Watts	694	712	729	747	765

CFM Versus Temperature Rise

Table 2. 2nd Stage Heating Table – Upflow

CFM VS. 2ND STAGE TEMPERATURE RISE												
MODEL	CFM (CUBIC FEET PER MINUTE)											
	800	900	1000	1100	1200	1300	1400	1500	1600	1700	1800	1900
S9X2B060U4PSBB		60	54	49	45	41	38	36	34	32		

Table 3. 1st Stage Heating Table – Upflow

CFM VS. 1ST STAGE TEMPERATURE RISE																		
MODEL	CFM (CUBIC FEET PER MINUTE)																	
	400	500	600	700	800	900	1000	1100	1200	1300	1400	1500	1600	1700	1800	1900	2000	2100
S9X2B060U4PSBB				50	44	39	35	32	29	27	25							

General Features

NATURAL GAS MODELS

Central Heating furnace designs are certified by the Intertek/ETL for both natural and Propane gas. Limit setting and rating data were established and approved under standard rating conditions using American National Standards Institute standards.

SAFE OPERATION

The Integrated Furnace Control is a solid state device which continuously monitors for presence of flame when the system is in the heating mode of operation. Dual solenoid combination gas valve and regulator provide additional safety.

QUICK HEATING

Durable, cycle tested, heavy gauge **tubular stainless steel primary heat exchanger** quickly transfers heat to provide warm conditioned air to the structure. **Low energy power vent blower**, to increase efficiency and provide a positive discharge of gas fumes to the outside.

BURNERS

Multiport Inshot burners will give years of quiet and efficient service. All models can be converted to **Propane** with Propane conversion kit.

INTEGRATED FURNACE CONTROL

Exclusively designed operational program provides total control of furnace limit sensors, blowers, gas valve, flame control and includes self diagnostics for ease of service. Also contains dry contacts for EAC and HUM.

ENERGY EFFICIENT OPERATION

Furnace is certified by the manufacturer to leak 1% or less of nominal air conditioning CFM delivered when pressurized to .5" water column with all inlets, outlets, and drains sealed.

AIR DELIVERY

The 9 speed blower motor has sufficient airflow for most heating and cooling requirements and will switch from heating to cooling speeds on demand from room thermostat.

SECONDARY HEAT EXCHANGER

The S-Series furnace has a special type 29- 4C™ stainless steel secondary heat exchanger to reclaim heat from flue gases which would normally be lost.

STYLING

Heavy gauge steel and "wrap-around" cabinet construction is used in the cabinet with baked-on enamel finish for strength and beauty. Every orientation has at least two venting options. There are no knockouts on cabinet.

FEATURES AND GENERAL OPERATION

The S-Series furnace utilizes a Silicon Nitride Hot Surface Ignition system, which eliminates the waste of a constant burning pilot. The integrated furnace control lights the main burners upon a demand for heat from the room thermostat. Complete front service access.

- a. Low energy power venter
- b. Vent proving pressure switches.

Features and Benefits

UP TO 96.0% AFUE ON S9X2 FURNACE MODELS

Meets utility rebates

Lowers utility bills

ELECTRICALLY EFFICIENT

Efficient airflow design reduces electrical energy use

34 INCH TALL

Lighter, easier to move and fit into tight spaces like short basements or tight closets

Works great with larger, high-efficiency coils

No knockouts

3-WAY MULTI-POISE / DEDICATED DOWNFLOW

6 SKU's — Upflow / Horizontal Left / Horizontal Right

5 SKU's — Downflow

Added application flexibility and reduction in specification errors

AIRFLOW

At least 400 CFM/ton at 0.5 in. H₂O external static pressure

REGULATORY

All models are air tight; 1% or less air leakage as per ASHRAE 193

Open vestibule design provides a full 34" high open vestibule

DIMENSIONS

Widths are industry standard: 17.5", 21", and 24.5"

Depth remains approximately 28"

Cabinet will be compatible with industry standard coils, as well as, other accessories

INTEGRATED FURNACE CONTROL

Setup / Status / Diagnostics / Digital Display

No dip switches

Last six errors stored

Dry contact EAC and HUM connections

All multi-pin polarized terminals; no spade terminals

Low voltage labeled above and below

TUBULAR STAINLESS STEEL PRIMARY HEAT EXCHANGER

29-4C STAINLESS STEEL SECONDARY HEAT EXCHANGER

Stainless steel is a more durable, corrosive-resistant material than aluminumized steel

Integrated rail system for easy access if required

Reduces or eliminates need for baffles

VORTICA BLOWER, DESIGNED EXCLUSIVELY FOR THE S-SERIES FURNACE

Improved airflow efficiency

Durable, easy to clean, two piece housing

Single piece belly band/ motor arm assembly

Blower deck has full-length rails for easy removal and replacement, regardless of poise

THREE-WAY MULTI-POISE (UPFLOW, HORIZONTAL LEFT AND RIGHT) PLUS DEDICATED DOWNFLOW

Easier to specify

Shipped ready to install (no conversion kits required)

Every model has at least two venting options

Vent table improvements including longer vent lengths; 2" pipe can be used up to 100K

About Trane and American Standard Heating and Air Conditioning

Trane and American Standard create comfortable, energy efficient indoor environments for residential applications. For more information, please visit www.trane.com or www.americanstandardair.com.



The manufacturer has a policy of continuous data improvement and it reserves the right to change design and specifications without notice. We are committed to using environmentally conscious print practices.