

Submittal

Upflow / Horizontal Left/Right Single Stage Condensing Gas Fired Furnace 80,000 BTUH

Upflow, Convertible to
Horizontal Right or
Horizontal Left
S9X1C080U5PSBB
S9B1C080U5PSAB

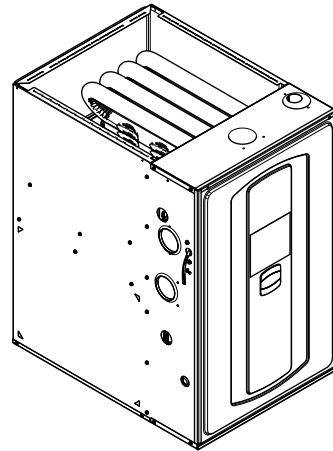

Note: Graphics in this document are for representation only. Actual model may differ in appearance.

⚠ WARNING

FIRE HAZARD!

Failure to follow this Warning could result in property damage, severe personal injury, or death.

This Warning applies to installations with a flammable refrigeration system. The furnace must be powered except for service. The furnace shall be installed and connected according to installation instructions and wiring diagrams that are provided with the evaporator coil.

⚠ CAUTION

COIL REQUIREMENT!

Failure to follow this Caution could result in property damage or personal injury. "GXC" and "MXC" coils installed on upflow furnaces in vertical, horizontal left, or horizontal right orientations without a factory installed metal drain pan shield must use a MAY*FERCOLKITAA kit. Coils installed on upflow furnaces must have drain pans that are suitable for 400° F (205°C) or have a metal drain pan shield. Downflow furnaces do not require a metal drain pan shield or the use of the MAY*FERCOLKITAA kit. See Installer's Guide for more information.

Product Specifications

MODEL	S9X1C080U5PSBB ^(a) S9B1C080U5PSAB
TYPE	Upflow/Horizontal
RATINGS ^(b)	
Input BTUH	80,000
Capacity BTUH (ICS) ^{(c) (d)}	77,800
Temp. Rise (Min.-Max.)	40 - 70
AFUE (%) S9X1 / S9B1 ^(d)	96.0 / 92.1
Return Air Temp. (Min. - Max.)	45°F - 80°F
BLOWER DRIVE	DIRECT
Diameter — Width (In.)	11 X 10
No. Used	1
Speeds (No.) ^(e)	9
CFM vs. in. w.g.	See Fan Performance Table
Motor HP	1
RPM	1075
Volts/Ph/Hz	120 / 1 / 60
FLA	10.6
COMBUSTION FAN — Type	Centrifugal
Drive — No. Speeds	Direct - 1
Motor HP — RPM	3300
Volts/Ph/Hz	120 / 1 / 60
FLA	0.66
FILTER — Furnished?	No
Type recommended	High Velocity
Hi Vel. (No.-Size-Thk.)	1 - 20 X 25 - 1 in.
VENT PIPE DIAMETER — Min (in.) ^{(f) (g)}	2 Round
HEAT EXCHANGER	
Type — Fired	409 Stainless Steel

MODEL	S9X1C080U5PSBB ^(a) S9B1C080U5PSAB
— Unfired	29-4C Stainless Steel
Gauge (Fired)	20
ORIFICES — Main	
Nat. Gas Qty. — Drill Size	4 - 45
Propne Gas Qty. — Drill Size	4- 56
GAS VALVE	Redundant - One Stage
PILOT SAFETY DEVICE	
Type	120 V SiNi Igniter
BURNERS — Type	Multiport Inshot
Number	4
POWER CONN. — V/Ph/Hz ^(h)	120 / 1 / 60
Ampacity (In Amps)	14.1
Max. Overcurrent Protection (Amps)	15
PIPE CONN. SIZE (in.)	1/2
DIMENSIONS	H x W x D
Uncrated (In.)	34 x 21 x 28-3/4
Crated (In.)	35-1/2 x 23 x 30-7/8
WEIGHT	
Shipping (Lbs.)/Net (Lbs.)	149/139

^(a) Meets Energy Star

^(b) For U.S. applications, above input ratings (BTUH) are up to 2,000 feet, derate 4% per 1,000 feet for elevations above 2,000 feet above sea level. For Canadian applications, above input ratings (BTUH) are up to 4,500 feet, derate 4% per 1,000 feet for elevations above 4,500 feet above sea level.

^(c) Central Furnace heating designs are certified to ANSI Z21.47 / CSA 2.3 — latest edition.

^(d) Based on U.S. government standard tests.

^(e) 9 Speed constant torque ECM blower motor

^(f) Refer to the Vent Length Table in the Installer's Guide.

^(g) All furnace models have a vent outlet diameter that equals 2 in.

^(h) The above wiring specifications are in accordance with National Electrical Code; however, installations must comply with local codes.

Airflow tables

Furnace Airflow (CFM) Vs. External Static Pressure (in. W.C.)							
Model	Tap		0.1	0.3	0.5	0.7	0.9
S9X1C080U5PSBB S9B1C080U5PSAB	1	SCFM	643	384	125		
		Watts	45	53	62	-	-
	2	SCFM	1125	982	838	694	551
		Watts	126	142	158	174	190
	3	SCFM	1192	1038	884	730	576
		Watts	140	157	174	191	208
	4	SCFM	1509	1377	1246	1115	983
		Watts	245	268	291	314	337
	5	SCFM	1548	1428	1308	1187	1067
		Watts	257	281	304	328	352
	6	SCFM	1602	1467	1331	1196	1061
		Watts	320	345	371	396	421
	7	SCFM	1640	1512	1383	1255	1127
		Watts	352	379	406	433	459
	8	SCFM	1831	1778	1726	1673	1621
		Watts	521	550	579	608	637
	9	SCFM	2351	2278	2204	2131	2058
		Watts	886	918	950	982	1014

CFM Versus Temperature Rise

Table 2. Heating Table – Upflow

CFM VS. TEMPERATURE RISE													
MODEL													
	1000	1100	1200	1300	1400	1500	1600	1700	1800	1900	2000	2100	2200
S9X1C080U5PSBB S9B1C080U5PSAB	68	65	59	56	54	49	46	44					

General Features

NATURAL GAS MODELS

Central Heating furnace designs are certified by the Intertek/ETL for both natural and Propane gas. Limit setting and rating data were established and approved under standard rating conditions using American National Standards Institute standards.

SAFE OPERATION

The Integrated Furnace Control is a solid state device which continuously monitors for presence of flame when the system is in the heating mode of operation. Dual solenoid combination gas valve and regulator provide additional safety.

QUICK HEATING

Durable, cycle tested, heavy gauge **tubular stainless steel primary heat exchanger** quickly transfers heat to provide warm conditioned air to the structure. **Low energy power vent blower**, to increase efficiency and provide a positive discharge of gas fumes to the outside.

BURNERS

Multiport Inshot burners will give years of quiet and efficient service. All models can be converted to **Propane** with Propane conversion kit.

INTEGRATED FURNACE CONTROL

Exclusively designed operational program provides total control of furnace limit sensors, blowers, gas valve, flame control and includes self diagnostics for ease of service. S9X1 also contains dry contacts for EAC and HUM.

ENERGY EFFICIENT OPERATION

S9X1 Furnace is certified by the manufacturer to leak 1% (1.4% for S9B1) or less of nominal air conditioning CFM delivered when pressurized to .5" water column with all inlets, outlets, and drains sealed.

AIR DELIVERY

The 9 tap constant torque ECM blower motor has sufficient airflow for most heating and cooling requirements and will switch from heating to cooling speeds on demand from room thermostat.

SECONDARY HEAT EXCHANGER

The S-Series furnace has a special type 29- 4C™ stainless steel secondary heat exchanger to reclaim heat from flue gases which would normally be lost.

STYLING

Heavy gauge steel and "wrap-around" cabinet construction is used in the cabinet with baked-on enamel finish for strength and beauty. Every orientation has at least two venting options. There are no knockouts on cabinet.

FEATURES AND GENERAL OPERATION

The S-Series furnace utilizes a Silicon Nitride Hot Surface Ignition system, which eliminates the waste of a constant burning pilot. The integrated furnace control lights the main burners upon a demand for heat from the room thermostat. Complete front service access.

- a. Low energy power venter
- b. Vent proving pressure switches.

Features and Benefits

UP TO 96.0% AFUE ON S9X1 FURNACE MODELS

Meets utility rebates

Lowers utility bills

ELECTRICALLY EFFICIENT

Efficient airflow design reduces electrical energy use

34 INCH TALL

Lighter, easier to move and fit into tight spaces like short basements or tight closets

Works great with larger, high-efficiency coils

No knockouts

3-WAY MULTI-POISE / DEDICATED DOWNFLOW

6 SKU's — Upflow / Horizontal Left / Horizontal Right

5 SKU's — Downflow

Added application flexibility and reduction in specification errors

AIRFLOW

At least 400 CFM/ton at 0.5 in. H₂O external static pressure

REGULATORY

All models are air tight; 1% or less air leakage as per ASHRAE 193 (1.4% for S9B1)

Open vestibule design provides a full 34" high open vestibule

DIMENSIONS

Width is industry standard: 21"

Depth remains approximately 28"

Cabinet is compatible with industry standard coils as well as other accessories

INTEGRATED FURNACE CONTROL

Setup / Status / Diagnostics / Digital Display

No dip switches

Last six errors stored

Dry contact EAC and HUM connections on S9X1 models

All multi-pin polarized terminals connections; no spade terminals

Low voltage labeled above and below

TUBULAR STAINLESS STEEL PRIMARY HEAT EXCHANGER

29-4C STAINLESS STEEL SECONDARY HEAT EXCHANGER

Stainless steel is a more durable, corrosive-resistant material than aluminumized steel

Integrated rail system for easy access if required

Reduces or eliminates need for baffles

VORTICA BLOWER, DESIGNED EXCLUSIVELY FOR THE S-SERIES FURNACE

Improved airflow efficiency

Durable, easy to clean, two piece housing

Single piece belly band/ motor arm assembly

Blower deck has full-length rails for easy removal and replacement, regardless of poise

THREE-WAY MULTI-POISE (UPFLOW, HORIZONTAL LEFT AND RIGHT) PLUS DEDICATED DOWNFLOW

Easier to specify

Shipped ready to install (no conversion kits required)

Every model has at least two venting options

Barbed fitting on trap at hose connection and on cabinet transition for hose has barbed fitting and clamps at both ends for leak resistance.

Vent table improvements including longer vent lengths.

About Trane and American Standard Heating and Air Conditioning

Trane and American Standard create comfortable, energy efficient indoor environments for residential applications. For more information, please visit www.trane.com or www.americanstandardair.com.



The manufacturer has a policy of continuous data improvement and it reserves the right to change design and specifications without notice. We are committed to using environmentally conscious print practices.