

# Submittal

## Upflow / Downflow / Horizontal Left/Right Two Stage Non-condensing Gas Fired Furnace 80,000 BTUH

S8X2B080M4PSC

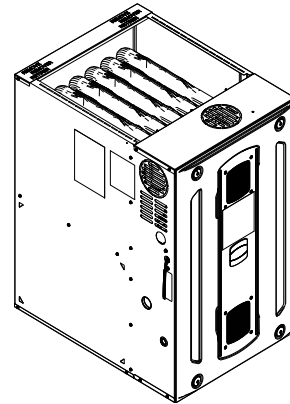

*Note: Models may have a "T" in the 12th digit designating they meet California less than 40 ng/J (NOx) emissions requirements.*

*Note: Graphics in this document are for representation only. Actual model may differ in appearance.*

# Outline Drawing

Table 1. 17.5" Width Cabinet

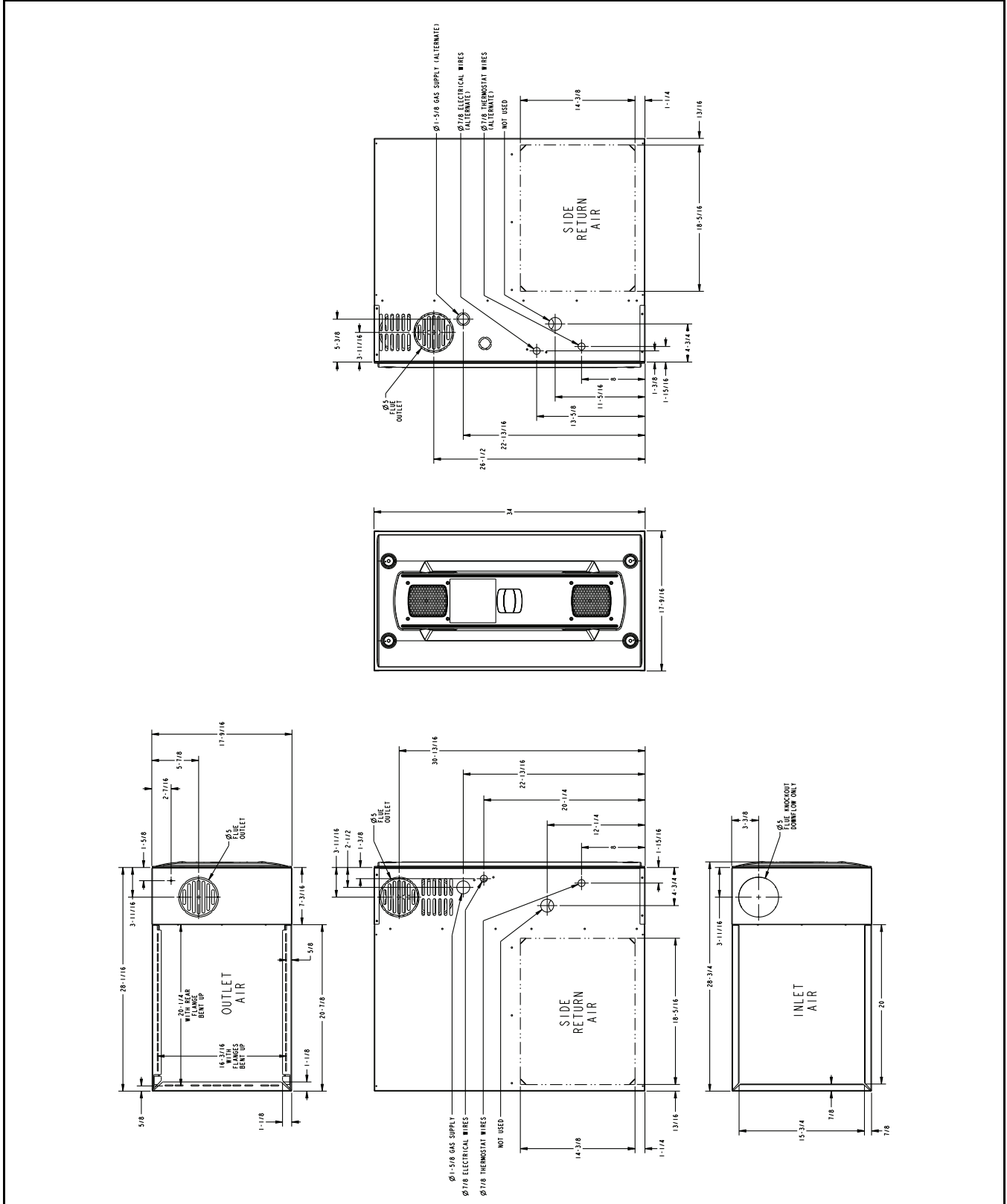

# Product Specifications

Model	S8X2B080M4PSC (a)
Type	Upflow / Horizontal / Downflow
<b>RATINGS (b)</b>	
1st Stage Input BTUH	52,000
1st Stage Capacity BTUH (ICS)	42,500
2nd Stage Input BTUH	80,000
2nd Stage Capacity BTUH (ICS) (c)	65,000
1st Stage Temp. Rise (Min. - Max.) °F	25 - 55
2nd Stage Temp. Rise (Min. - Max.) °F	30 - 60
AFUE (%) (c)	80
Return Air Temp. (Min. - Max.) °F	55°F - 80°F
<b>BLOWER DRIVE</b>	DIRECT
Diameter - Width (in.)	11 X 8
No. Used	1
Speeds (No.) (d)	CTM - 9
CFM vs. in. w.g.	See Fan Performance Table
Motor HP	3/4
R.P.M.	1050
Volts / Ph / Hz	120 / 1 / 60
FLA	9.2
<b>COMBUSTION FAN - Type</b>	PSC
Drive - No. Speeds	Direct - 2
Motor RPM	3300/2600
Volts/Ph/Hz	120 / 1 / 60
FLA	0.33
Inducer Orifice	1.75
<b>FILTER - Furnished?</b>	No

Model	S8X2B080M4PSC (a)
Type Recommended	High Velocity
Hi Vel. (No.-Size-Thk.)	1 - 16 X 25 - 1 in.
<b>VENT PIPE DIAMETER - Min. (in.) (e)</b>	4 Round
<b>HEAT EXCHANGER - Type</b>	Aluminized Steel
Gauge (Fired)	20 - 19
<b>ORIFICES - Main</b>	
Nat. Gas Qty. - Drill Size	4 - 45
L.P. Gas Qty. - Drill Size	4 - 56
<b>GAS VALVE</b>	Redundant - Two Stage
<b>PILOT SAFETY DEVICE - Type</b>	120 V SiNi Igniter
<b>BURNERS - QTY</b>	4
<b>POWER CONN. - V/Ph/HZ (f)</b>	120 / 1 / 60
Ampacity (Amps)	12.0
Max. Overcurrent Protection (Amps)	15
<b>PIPE CONN. SIZE (IN.)</b>	1/2
<b>DIMENSIONS</b>	H x W x D
Uncrated (in.)	34 x 17.5 x 28.75
Crated (in.)	35.5 x 19.5 x 30.87
<b>WEIGHT</b>	
Shipping (Lbs.)/Net (Lbs.)	137 / 129

- (a) Central Furnace heating designs are certified to ANSI Z21.47 - latest edition.
- (b) For U.S. applications, above input ratings (BTUH) are up to 2,000 feet, derate 4% per 1,000 feet for elevations above 2,000 feet above sea level.
- (c) Based on U.S. government standard tests
- (d) 9 Speed constant torque ECM Blower Motor.
- (e) Refer to the Installer's Guide.
- (f) The above wiring specifications are in accordance with National Electric Code, however, installations must comply with local codes.

# Airflow Table

Furnace Airflow (CFM) Vs. External Static Pressure (in. W.C.)							
Model	Tap	Static	0.1	0.3	0.5	0.7	0.9
S8X2B080M4PSC	1	SCFM	552	160			
		Watts	34	34			
	2	SCFM	891	720	549	378	207
		Watts	82	93	105	117	129
	3	SCFM	1123	996	869	742	615
		Watts	141	157	173	189	205
	4	SCFM	1344	1240	1136	1033	929
		Watts	224	244	263	283	302
	5	SCFM	1479	1384	1290	1196	1102
		Watts	290	312	333	354	375
	6	SCFM	1583	1496	1408	1321	1234
		Watts	354	376	398	420	442
	7	SCFM	1654	1572	1491	1409	1327
		Watts	405	428	451	474	496
	8	SCFM	1818	1739	1661	1582	1503
		Watts	542	561	581	600	619
	9	SCFM	1926	1841	1756	1670	1585
		Watts	645	656	667	679	690

# CFM Versus Temperature Rise

*S8X2 Furnaces have two stage heating. First Stage is Low heating and Second Stage is High heating.*

**Table 2. S8X2 – Low Heat**

Model	CFM Versus Temperature Rise – First Stage (Low) Heating																
	400	500	600	700	800	900	1000	1100	1200	1300	1400	1500	1600	1700	1800	1900	2000
S8X2B080M4PSC				55	48	43	39	35	32	30	28						

**Table 3. S8X2 – High Heat**

Model	CFM Versus Temperature Rise – Second Stage (High) Heating																				
	400	500	600	700	800	900	1000	1100	1200	1300	1400	1500	1600	1700	1800	1900	2000	2100	2200	2300	2400
S8X2B080M4PSC							59	54	49	46	42	40	37	35	33						

# General Features

## NATURAL GAS MODELS

Central Heating furnace designs are certified by Intertek for both natural and L.P. gas. Limit setting and rating data were established and approved under standard rating conditions using American National Standards Institute standards.

## SAFE OPERATION

The Integrated System Control is a solid state device which continuously monitors for presence of flame when the system is in the heating mode of operation. Dual solenoid combination gas valve and regulator provide additional safety.

## QUICK HEATING

Durable, cycle tested, heavy gauge **tubular aluminized steel heat exchanger** quickly transfers heat to provide warm conditioned air to the structure. **Low energy power vent blower**, to increase efficiency and provide a discharge of gas fumes to the outside.

## BURNERS

Multiport, Inshot burners will give years of quiet and efficient service. All models can be converted to **L.P. gas** with LP conversion kit.

## INTEGRATED SYSTEM CONTROL

Exclusively designed operational program provides total control of furnace limit sensors, blowers, gas

valve, flame control and includes self diagnostics for ease of service.

## ENERGY EFFICIENT OPERATION

Air-Tite™ cabinet design is certified to <1% air leakage per ASHRAE 193 "Method of Test for Determining the Airtightness of HVAC Equipment."

## AIR DELIVERY

The 9 speed constant torque blower motor has sufficient airflow for most heating and cooling requirements and will switch from heating to cooling speeds on demand from room thermostat.

## STYLING

**Heavy gauge steel and "wrap-around" cabinet construction** is used in the cabinet with baked-on enamel finish for strength and beauty. Every orientation has at least two venting options. There are no knockouts on cabinet.

## FEATURES AND GENERAL OPERATION

The S-Series furnace utilizes a Silicon Nitride Hot Surface Ignition system, which eliminates the waste of a constant burning pilot. The integrated system control lights the main burners upon a demand for heat from the room thermostat. Complete front service access.

- a. Low energy power venter
- b. Vent proving pressure switches.

# Features and Benefits

## **80% AFUE on S8X2 FURNACE MODELS**

Lowers utility bills

## **ELECTRICALLY EFFICIENT**

Efficient airflow design reduces electrical energy use

## **34 INCH TALL**

Lighter, easier to move and fit into tight spaces like short basements or tight closets

Works great with larger, high-efficiency coils

No knockouts

## **4-WAY MULTI-POISE**

6 SKU's — Upflow / Downflow / Horizontal Left / Horizontal Right

Added application flexibility and reduction in specification errors

## **AIRFLOW**

At least 400 CFM/ton at 0.5 in. H<sub>2</sub>O external static pressure

## **REGULATORY**

All models are air tight; 1% or less air leakage as per ASHRAE 193

Open vestibule design provides a full 34" high open vestibule for ease of installation and service

## **DIMENSIONS**

Width is industry standard: 17.5"

Depth remains approximately 28"

Cabinet is compatible with industry standard coils, as well as, other accessories

## **INTEGRATED FURNACE CONTROL**

Setup / Status / Diagnostics / Digital Display

No dip switches

Last six errors stored

Dry contact EAC and HUM connections

All Molex connections; no spade terminals

Low voltage labeled above and below

Rain shield over IFC keeps condensate off the control

## **TUBULAR ALUMINIZED STEEL HEAT EXCHANGER**

## **VORTICA II BLOWER, DESIGNED EXCLUSIVELY FOR THE S-SERIES FURNACE**

Improved airflow efficiency

Durable, easy to clean, housing

Single piece belly band/ motor arm assembly

Blower deck has full-length rails for easy removal and replacement, regardless of poise

## **FOUR-WAY MULTI-POISE (UPFLOW, DOWNFLOW, HORIZONTAL LEFT AND RIGHT)**

Easier to specify

Shipped ready to install (no conversion kits required)

Every model has at least two venting options

## About Trane and American Standard Heating and Air Conditioning

Trane and American Standard create comfortable, energy efficient indoor environments for residential applications. For more information, please visit [www.trane.com](http://www.trane.com) or [www.americanstandardair.com](http://www.americanstandardair.com).

---



Intertek

The manufacturer has a policy of continuous data improvement and it reserves the right to change design and specifications without notice. We are committed to using environmentally conscious print practices.

S8X2B080M4-SUB-2E-EN 31 Mar 2023

Supersedes S8X2B080M4-SUB-2D-EN (September 2021)

©2023