

# SERVICE MANUAL

## Series PKFY Wall Mounted R454B

Indoor unit

[Model Name]

[Service Ref.]

PKFY-L04NLMU-A **PKFY-L04NLMU-A**

PKFY-L06NLMU-A **PKFY-L06NLMU-A**

PKFY-L08NLMU-A **PKFY-L08NLMU-A**

PKFY-L12NLMU-A **PKFY-L12NLMU-A**

PKFY-L15NLMU-A **PKFY-L15NLMU-A**

PKFY-L18NLMU-A **PKFY-L18NLMU-A**

Revision:

- "3. SPECIFICATION" has been revised in REVISED EDITION-A.

OCH863 is void.

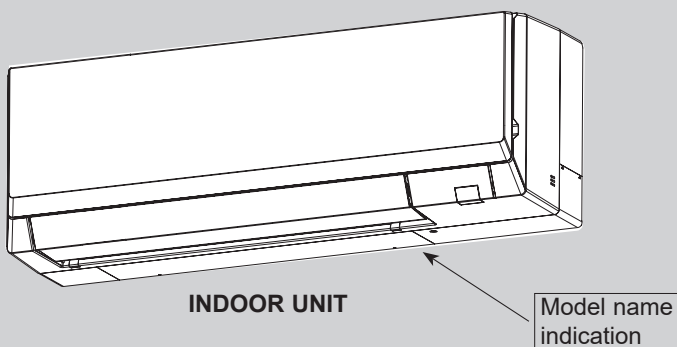

WIRELESS REMOTE  
CONTROLLER  
(Option)

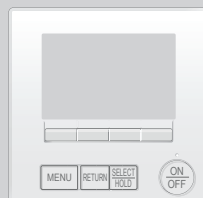

WIRED REMOTE  
CONTROLLER  
(Option)

## CONTENTS

1. SAFETY PRECAUTION .....	2
2. PARTS NAMES AND FUNCTIONS .....	7
3. SPECIFICATION .....	8
4. NOISE CRITERION CURVES .....	11
5. OUTLINES AND DIMENSIONS .....	13
6. WIRING DIAGRAM .....	15
7. REFRIGERANT SYSTEM DIAGRAM .....	16
8. MICROPROCESSOR CONTROL .....	16
9. TROUBLESHOOTING .....	23
10. DISASSEMBLY PROCEDURE .....	35
11. REMOTE CONTROLLER .....	40





**PARTS CATALOG (OCB863)**

# CITY MULTI

# 1

# SAFETY PRECAUTION

## MEANINGS OF SYMBOLS DISPLAYED ON THE UNIT

	<b>WARNING</b> (Risk of fire)	This unit uses a flammable refrigerant. If the refrigerant leaks and comes in contact with fire or a heating part, it will create a harmful gas and there is risk of fire.
		Read the OPERATION MANUAL carefully before operation.
		Service personnel are required to carefully read the OPERATION MANUAL and INSTALLATION MANUAL before operation.
		Further information is available in the OPERATION MANUAL, INSTALLATION MANUAL, and the like.

### 1-1. ALWAYS OBSERVE FOR SAFETY

**Before obtaining access to terminal, all supply circuits must be disconnected.**

### 1-2. CAUTIONS RELATED TO REFRIGERANT

Cautions for units utilizing refrigerant R454B

#### Do not use the existing refrigerant piping.

The old refrigerant and lubricant in the existing piping contains a large amount of chlorine which may cause the lubricant deterioration of the new unit.

**Make sure that the inside and outside of refrigerant piping is clean and it has no contaminants such as sulfur, oxides, dirt, shaving particles, etc., which are hazard to refrigerant cycle. In addition, use pipes with specified thickness.**

Contamination inside refrigerant piping can cause deterioration of refrigerant oil, etc.

**Store the piping indoors, and keep both ends of the piping sealed until just before brazing. (Leave elbow joints, etc. in their packaging.)**

If dirt, dust or moisture enters into refrigerant cycle, that can cause deterioration of refrigerant oil or malfunction of compressor.

**The refrigerant oil applied to flare and flange connections must be ester oil, ether oil or alkylbenzene oil in a small amount.**

If large amount of mineral oil enters, that can cause deterioration of refrigerant oil, etc.

**Charge refrigerant from liquid phase of gas cylinder.**

If the refrigerant is charged from gas phase, composition change may occur in refrigerant and the efficiency will be lowered.

**Ventilate the room if refrigerant leaks during operation. If refrigerant comes into contact with a flame, poisonous gases will be released.**

#### Use a vacuum pump with a reverse flow check valve.

Vacuum pump oil may flow back into refrigerant cycle and that can cause deterioration of refrigerant oil, etc.

#### Use the following tools specifically designed for use with R454B refrigerant.

The following tools are necessary to use R454B refrigerant.

Tools for R454B	
Gauge manifold	Flare tool
Charge hose	Size adjustment gauge
Gas leak detector	Vacuum pump adaptor
Torque wrench	Electronic refrigerant charging scale

#### Handle tools with care.

If dirt, dust or moisture enters into refrigerant cycle, that can cause deterioration of refrigerant oil or malfunction of compressor.

#### Do not use a charging cylinder.

If a charging cylinder is used, the composition of refrigerant will change and the efficiency will be lowered.

#### Use the specified refrigerant only.

**Never use any refrigerant other than that specified.**

Doing so may cause a burst, an explosion, or fire when the unit is being used, serviced, or disposed of.

Correct refrigerant is specified on name plate of outdoor unit.

If other refrigerant (R22, etc.) is used, chlorine in refrigerant can cause deterioration of refrigerant oil, etc.

We will not be held responsible for mechanical failure, system malfunction, unit breakdown or accidents caused by failure to follow the instructions.

## **[1] Warning for service**

- (1) Do not alter the unit.
- (2) For installation and relocation work, follow the instructions in the Installation Manual and use tools and pipe components specifically made for use with refrigerant specified in the outdoor unit installation manual.
- (3) Ask a dealer or an authorized technician to install, relocate and repair the unit.
- (4) This unit should be installed in rooms which exceed the floor space specified in outdoor unit installation manual. Refer to outdoor unit installation manual.
- (5) Install the indoor unit at least 1.8 m above floor or grade level.  
For appliances not accessible to the general public.
- (6) Refrigerant pipes connection shall be accessible for maintenance purposes.
- (7) If the air conditioner is installed in a small room or closed room, measures must be taken to prevent the refrigerant concentration in the room from exceeding the safety limit in the event of refrigerant leakage. Should the refrigerant leak and cause the concentration limit to be exceeded, hazards due to lack of oxygen in the room may result.
- (8) Keep gas-burning appliances, electric heaters, and other fire sources (ignition sources) away from the location where installation, repair, and other air conditioner work will be performed.  
If refrigerant comes into contact with a flame, poisonous gases will be released.
- (9) When installing or relocating, or servicing the air conditioner, use only the specified refrigerant written on outdoor unit to charge the refrigerant lines.  
Do not mix it with any other refrigerant and do not allow air to remain in the lines.  
If air is mixed with the refrigerant, then it can be the cause of abnormal high pressure in the refrigerant line, and may result in an explosion and other hazards.
- (10) After installation has been completed, check for refrigerant leaks. If refrigerant leaks into the room and comes into contact with the flame of a heater or portable cooking range, poisonous gases will be released.
- (11) Do not use low temperature solder alloy in case of brazing the refrigerant pipes.
- (12) When performing brazing work, be sure to ventilate the room sufficiently. Make sure that there are no hazardous or flammable materials nearby.  
When performing the work in a closed room, small room, or similar location, make sure that there are no refrigerant leaks before performing the work.  
If refrigerant leaks and accumulates, it may ignite or poisonous gases may be released.
- (13) Do not install the unit in places where refrigerant may build-up or places with poor ventilation such as a semi-basement or a sunken place in outdoor: Refrigerant is heavier than air, and inclined to fall away from the leak source.
- (14) Do not use means to accelerate the defrosting process or to clean, other than those recommended by the manufacturer.
- (15) The appliance shall be stored in a room without continuously operating ignition sources (for example: open flames, an operating gas appliance or an operating electric heater).
- (16) Do not pierce or burn.
- (17) Be aware that refrigerants may not contain an odor.
- (18) Pipe-work shall be protected from physical damage.
- (19) The installation of pipe-work shall be kept to a minimum.
- (20) Compliance with national gas regulations shall be observed.
- (21) Keep any required ventilation openings clear of obstruction.
- (22) Servicing shall be performed only as recommended by the manufacturer.
- (23) The appliance shall be stored in a well-ventilated area where the room size corresponds to the room area as specified for operation.
- (24) Maintenance, service and repair operations shall be performed by authorized technician with required qualification.

## **[2] Cautions for service**

- (1) Perform service after recovering the refrigerant left in unit completely.
- (2) Do not release refrigerant in the air.
- (3) After completing service, charge the cycle with specified amount of refrigerant.
- (4) When performing service, install a filter drier simultaneously.  
Be sure to use a filter drier for new refrigerant.

## **[3] Additional refrigerant charge**

### **When charging directly from cylinder**

- (1) Check that cylinder for R454B available on the market is a syphon type.
- (2) Charging should be performed with the cylinder of syphon stood vertically. (Refrigerant is charged from liquid phase.)

#### [4] Cautions for unit using R454B refrigerant

Basic work procedures are the same as those for conventional units using refrigerant R410A. However, pay careful attention to the following points:

- (1) Information on servicing
  - (1-1) Checks on the area

Prior to beginning work on systems containing FLAMMABLE REFRIGERANTS, safety checks are necessary to ensure that the risk of ignition is minimized.

For repair to the REFRIGERATING SYSTEM, 1-2 to 1-6 shall be completed prior to conducting work on the system.
  - (1-2) Work procedure

Work shall be undertaken under a controlled procedure so as to minimize the risk of a flammable gas or vapor being present while the work is being performed.
  - (1-3) General work area

All maintenance staff and others working in the local area shall be instructed on the nature of work being carried out.

Work in confined spaces shall be avoided.
  - (1-4) Checking for presence of refrigerant

The area shall be checked with an appropriate refrigerant detector prior to and during work, to ensure the technician is aware of potentially toxic or flammable atmospheres. Ensure that the leak detection equipment being used is suitable for use with all applicable refrigerants, i.e. non-sparking, adequately sealed or intrinsically safe.
  - (1-5) Presence of fire extinguisher

If any hot work is to be conducted on the refrigerating equipment or any associated parts, appropriate fire extinguishing equipment shall be available to hand.

Have a dry powder or CO2 fire extinguisher adjacent to the charging area.
  - (1-6) No ignition sources

No person carrying out work in relation to a REFRIGERATING SYSTEM which involves exposing any pipe work shall use any sources of ignition in such a manner that it may lead to the risk of fire or explosion.

All possible ignition sources, including cigarette smoking, should be kept sufficiently far away from the site of installation, repairing, removing and disposal, during which refrigerant can possibly be released to the surrounding space.

Prior to work taking place, the area around the equipment is to be surveyed to make sure that there are no flammable hazards or ignition risks. "No Smoking" signs shall be displayed.
  - (1-7) Ventilated area

Ensure that the area is in the open or that it is adequately ventilated before breaking into the system or conducting any hot work. A degree of ventilation shall continue during the period that the work is carried out.

The ventilation should safely disperse any released refrigerant and preferably expel it externally into the atmosphere.
  - (1-8) Checks on the refrigeration equipment

Where electrical components are being changed, they shall be fit for the purpose and to the correct specification.

At all times the manufacturer's maintenance and service guidelines shall be followed.

If in doubt, consult the manufacturer's technical department for assistance.

The following checks shall be applied to installations using FLAMMABLE REFRIGERANTS:

    - the actual REFRIGERANT CHARGE is in accordance with the room size within which the refrigerant containing parts are installed;
    - the ventilation machinery and outlets are operating adequately and are not obstructed;
    - marking to the equipment continues to be visible and legible. Markings and signs that are illegible shall be corrected;
    - refrigerating pipe or components are installed in a position where they are unlikely to be exposed to any substance which may corrode refrigerant containing components, unless the components are constructed of materials which are inherently resistant to being corroded or are suitably protected against being so corroded.
  - (1-9) Checks on electrical devices

Repair and maintenance to electrical components shall include initial safety checks and component inspection procedures.

If a fault exists that could compromise safety, then no electrical supply shall be connected to the circuit until it is satisfactorily dealt with. If the fault cannot be corrected immediately but it is necessary to continue operation, an adequate temporary solution shall be used. This shall be reported to the owner of the equipment so all parties are advised.

Initial safety checks shall include:

    - that capacitors are discharged: this shall be done in a safe manner to avoid possibility of sparking;
    - that no live electrical components and wiring are exposed while charging, recovering or purging the system;
    - that there is continuity of earth bonding.
    -
- (2) Repairs to sealed components

Sealed electrical components shall be replaced
- (3) Repair to intrinsically safe components

Intrinsically safe components must be replaced.
- (4) Cabling

Check that cabling will not be subject to wear, corrosion, excessive pressure, vibration, sharp edges or any other adverse environmental effects.

The check shall also take into account the effects of aging or continual vibration from sources such as compressors or fans.

(5) Detection of flammable refrigerants

Under no circumstances shall potential sources of ignition be used in the searching for or detection of refrigerant leaks.

A halide torch (or any other detector using a naked flame) shall not be used.

The following leak detection methods are deemed acceptable for all refrigerant systems.

Electronic leak detectors may be used to detect refrigerant leaks but, in the case of FLAMMABLE REFRIGERANTS, the sensitivity may not be adequate, or may need re-calibration. (Detection equipment shall be calibrated in a refrigerant-free area.) Ensure that the detector is not a potential source of ignition and is suitable for the refrigerant used.

Leak detection equipment shall be set at a percentage of the LFL of the refrigerant and shall be calibrated to the refrigerant employed, and the appropriate percentage of gas (25 % maximum) is confirmed.

Leak detection fluids are also suitable for use with most refrigerants but the use of detergents containing chlorine shall be avoided as the chlorine may react with the refrigerant and corrode the copper pipe-work.

If a leak is suspected, all naked flames shall be removed/extinguished.

If a leakage of refrigerant is found which requires brazing, all of the refrigerant shall be recovered from the system, or isolated (by means of shut off valves) in a part of the system remote from the leak. Removal of refrigerant shall be according to 2-4.6.

(6) Removal and evacuation

When breaking into the refrigerant circuit to make repairs - or for any other purpose -conventional procedures shall be used. However, for flammable refrigerants it is important that best practice be followed, since flammability is a consideration. The following procedure shall be adhered to:

- safely remove refrigerant following local and national regulations;
- evacuate;
- purge the circuit with inert gas;
- evacuate;
- continuously flush or purge with inert gas when using flame to open circuit;
- open the circuit.

The refrigerant charge shall be recovered into the correct recovery cylinders if venting is not allowed by local and national codes. For appliances containing flammable refrigerants, the system shall be purged with oxygen-free nitrogen to render the appliance safe for flammable refrigerants. This process might need to be repeated several times.

Compressed air or oxygen shall not be used for purging refrigerant systems.

For appliances containing flammable refrigerants, refrigerants purging shall be achieved by breaking the vacuum in the system with oxygen-free nitrogen and continuing to fill until the working pressure is achieved, then venting to atmosphere, and finally pulling down to a vacuum.

This process shall be repeated until no refrigerant is within the system. When the final oxygen-free nitrogen charge is used, the system shall be vented down to atmospheric pressure to enable work to take place.

The outlet for the vacuum pump shall not be close to any potential ignition sources, and ventilation shall be available.

(7) Charging procedures

In addition to conventional charging procedures, the following requirements shall be followed:

- Ensure that contamination of different refrigerants does not occur when using charging equipment. Hoses or lines shall be as short as possible to minimize the amount of REFRIGERANT contained in them.
- Cylinders shall be kept in an appropriate position according to the instructions.
- Ensure that the REFRIGERATING SYSTEM is earthed prior to charging the system with refrigerant.
- Label the system when charging is complete (if not already).
- Extreme care shall be taken not to overfill the REFRIGERATING SYSTEM.

Prior to recharging the system, it shall be pressure-tested with the appropriate purging gas. The system shall be leak-tested on completion of charging but prior to commissioning.

A follow up leak test shall be carried out prior to leaving the site.

(8) Decommissioning

Before carrying out this procedure, it is essential that the technician is completely familiar with the equipment and all its detail. It is recommended good practice that all refrigerants are recovered safely.

Prior to the task being carried out, an oil and refrigerant sample shall be taken in case analysis is required prior to re-use of recovered refrigerant. It is essential that electrical power is available before the task is commenced.

a) Become familiar with the equipment and its operation.

b) Isolate system electrically.

c) Before attempting the procedure, ensure that:

- mechanical handling equipment is available, if required, for handling refrigerant cylinders;
- all personal protective equipment is available and being used correctly;
- the recovery process is supervised at all times by a competent person;
- recovery equipment and cylinders conform to the appropriate standards.

d) Pump down refrigerant system, if possible.

e) If a vacuum is not possible, make a manifold so that refrigerant can be removed from various parts of the system.

f) Make sure that cylinder is situated on the scales before recovery takes place.

g) Start the recovery machine and operate in accordance with instructions.

h) Do not overfill cylinders (no more than 80 % volume liquid charge).

i) Do not exceed the maximum working pressure of the cylinder, even temporarily.

- j) When the cylinders have been filled correctly and the process completed, make sure that the cylinders and the equipment are removed from site promptly and all isolation valves on the equipment are closed off.
- k) Recovered refrigerant shall not be charged into another REFRIGERATING SYSTEM unless it has been cleaned and checked.

(9) Labelling

Equipment shall be labelled stating that it has been de-commissioned and emptied of refrigerant. The label shall be dated and signed. For appliances containing FLAMMABLE REFRIGERANTS, ensure that there are labels on the equipment stating the equipment contains FLAMMABLE REFRIGERANT.

(10) Recovery

When removing refrigerant from a system, either for servicing or decommissioning, it is recommended good practice that all refrigerants are removed safely.

When transferring refrigerant into cylinders, ensure that only appropriate refrigerant recovery cylinders are employed. Ensure that the correct number of cylinders for holding the total system charge is available.

All cylinders to be used are designated for the recovered refrigerant and labelled for that refrigerant (i.e. special cylinders for the recovery of refrigerant). Cylinders shall be complete with pressure-relief valve and associated shut-off valves in good working order.

Empty recovery cylinders are evacuated and, if possible, cooled before recovery occurs.

The recovery equipment shall be in good working order with a set of instructions concerning the equipment that is at hand and shall be suitable for the recovery of the flammable refrigerant.

If in doubt, the manufacturer should be consulted. In addition, a set of calibrated weighing scales shall be available and in good working order. Hoses shall be complete with leak-free disconnect couplings and in good condition.

The recovered refrigerant shall be processed according to local legislation in the correct recovery cylinder, and the relevant waste transfer note arranged. Do not mix refrigerants in recovery units and especially not in cylinders.

If compressors or compressor oils are to be removed, ensure that they have been evacuated to an acceptable level to make certain that flammable refrigerant does not remain within the lubricant.

The compressor body shall not be heated by an open flame or other ignition sources to accelerate this process. When oil is drained from a system, it shall be carried out safely.

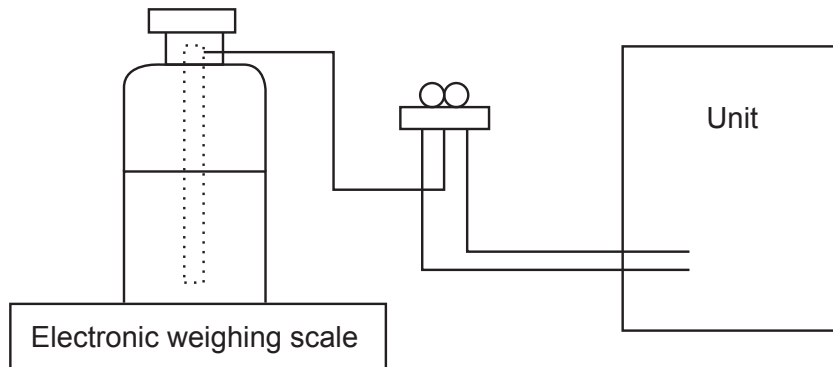

**[3] Service tools**

Use the below service tools as exclusive tools for R454B refrigerant.

No.	Tool name	Specifications
①	Gauge manifold	<ul style="list-style-type: none"> <li>· Only for R454B</li> <li>· Use the existing fitting specifications. (UNF1/2)</li> <li>· Use high-tension side pressure of 768.7 PSIG [5.3MPa.G] or over.</li> </ul>
②	Charge hose	<ul style="list-style-type: none"> <li>· Only for R454B</li> <li>· Use pressure performance of 738.2 PSIG [5.09MPa.G] or over.</li> </ul>
③	Electronic weighing scale	—
④	Gas leak detector	· Use the detector for R454B.
⑤	Adaptor for reverse flow check	· Attach on vacuum pump.
⑥	Refrigerant charge base	—
⑦	Refrigerant cylinder	<ul style="list-style-type: none"> <li>· Only for R454B</li> <li>· Cylinder with syphon</li> </ul>
⑧	Refrigerant recovery equipment	—

# 2

# PARTS NAMES AND FUNCTIONS

## 2-1. Indoor unit

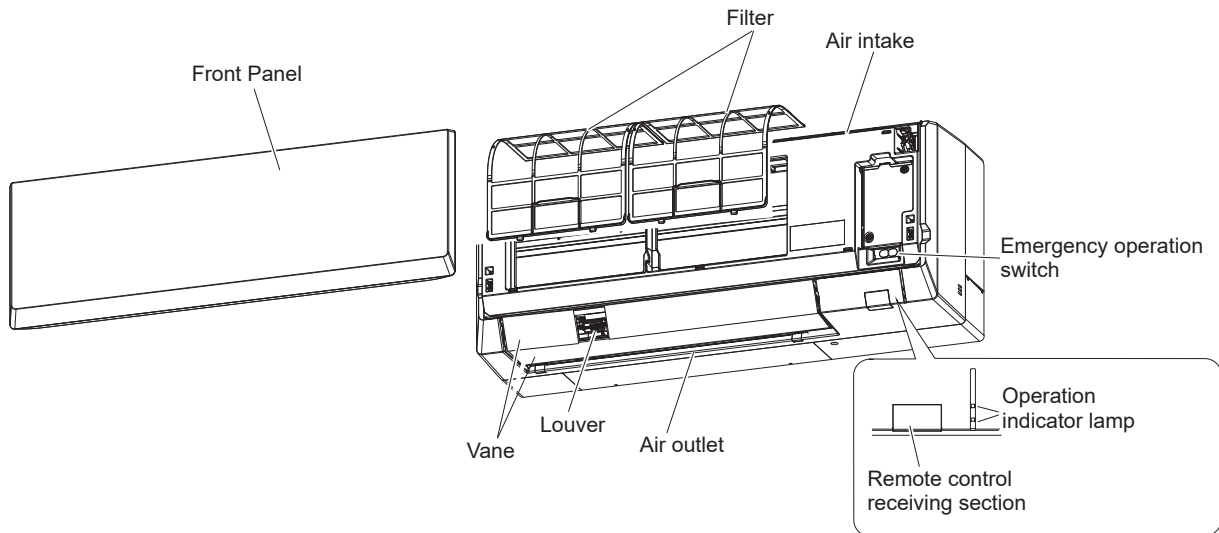

## 2-2. Wired Remote Controller <PAR-42MAAUB> <PAC-YT53CRAU>

### Wired remote controller function

The functions which can be used are restricted according to each model.

○ : Supported ✕ : Unsupported

	Function	PAR-42MAAUB		PAC-YT53CRAU
		Slim	CITY MULTI	
Body	Product size H × W × D mm (in.)	120 × 120 × 14.5 (4-3/4 × 4-3/4 × 9/16)		120 × 70 × 14.5 (4-3/4 × 2-3/4 × 9/16)
	LCD	Full Dot LCD		Partial Dot LCD
	Backlight	○		○
Energy saving	Energy saving operation schedule	○	✕	✕
	Automatic return to the preset temperature	○		✕
Restriction	Setting the temperature range restriction	○		○
Function*	Operation lock function	○		○
	Weekly timer	○		✕
	ON/OFF timer	○		✕
	High Power	○	✕	✕
	Manual vane angle	○		✕

\*Some functions may not be available depending on model types.

## 3-1. SPECIFICATIONS

Model			PKFY-L04NLMU-A	PKFY-L06NLMU-A	PKFY-L08NLMU-A	
Power source			1-phase 208/230 V 60 Hz			
Cooling capacity (Nominal)	*1	kW	1.1	1.8	2.3	
	*1	BTU/h	4000	6000	8000	
		Power input	kW	0.02	0.03	
		Current input	A	0.20	0.25	
Heating capacity (Nominal)	*2	kW	1.3	2.0	2.6	
	*2	BTU/h	4500	6700	9000	
		Power input	kW	0.01	0.02	
		Current input	A	0.15	0.20	
External finish(Munsell No.)			Plastic (0.7PB 9.2/0.4)			
External dimension H x W x D		mm [in.]	299 × 773 × 237 [11-25/32 x 30-7/16 x 9-11/32]			
Net weight		kg [lbs]	10.7 [23.6]	11.1 [24.5]		
Heat exchanger			Cross fin (Aluminum fin and copper tube)			
Fan	Type x Quantity		Line flow fan x 1			
	External static press	Pa	0 (0)			
	Motor type		DC motor			
	Motor output	kW	0.03			
	Driving mechanism		Direct driven			
	Airflow rate (Low-Mid2 -Mid1-High)	m <sup>3</sup> /min	3.3-3.5-3.8-4.2	4.0-4.4-4.9-5.4	4.0-4.6-5.4-6.7	
		cfm	117-124-134-148	141-155-173-191	141-162-191-237	
Noise level (Low-Mid2-Mid1-High) (measured in anechoic room)		dB <A>	22-24-26-28	22-26-29-31	22-27-31-35	
Insulation material			Polyethylene sheet			
Air filter			PP Honeycomb			
Protection device			Fuse			
Refrigerant control device			LEV			
Connectable outdoor unit			R454B CITY MULTI			
Diameter of refrigerant pipe	Liquid	mm [in.]	ø6.35 [ø1/4]			
	Gas	mm [in.]	ø12.7 [ø1/2]			
Field drain pipe size		mm [in.]	I.D. 16 [5/8]			
Standard attachment			Installation Manual, Instruction Book			
Optional parts	DRAIN PUMP KIT		PAC-SL48DM-E			
Remark			Details on foundation work, duct work, insulation work, electrical wiring, power source switch, and other items shall be referred to the Installation Manual. Due to continuing improvement, above specifications may be subject to change without notice.			
Notes:				Unit converter		
*1.Nominal cooling conditions (subject to JIS B8615-1) Indoor: 27°C.D.B./19°C.W.B. (81°F.D.B./66°F.W.B.), Outdoor: 35°C.D.B. (95°F.D.B.) Pipe length: 7.5 m (24-9/16 ft), Level difference: 0 m (0 ft)				kcal/h = kW × 860 Btu/h = kW × 3,412 cfm = m <sup>3</sup> /min × 35.31 lb = kg/0.4536		
*2.Nominal heating conditions (subject to JIS B8615-1) Indoor: 20°C.D.B. (68°F.D.B.), Outdoor: 7°C.D.B./6°C.W.B. (45°F.D.B./43°F.W.B.) Pipe length: 7.5 m (24-9/16 ft), Level difference: 0 m (0 ft)				Note: Above specification data is subject to rounding variation.		

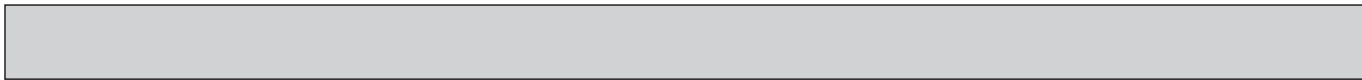

Model			PKFY-L12NLMU-A	PKFY-L15NLMU-A	PKFY-L18NLMU-A	
Power source			1-phase 208/230 V 60 Hz			
Cooling capacity (Nominal)	*1	kW	3.5	4.4	5.3	
	*1	BTU/h	12000	15000	18000	
		Power input	kW	0.04	0.05	
		Current input	A	0.35	0.45	
Heating capacity (Nominal)	*2	kW	4.0	5.0	5.9	
	*2	BTU/h	13500	17000	20000	
		Power input	kW	0.03	0.04	
		Current input	A	0.30	0.40	
External finish(Munsell No.)			Plastic (0.7PB 9.2/0.4)			
External dimension H x W x D		mm [in.]	299 × 773 × 237 [11-25/32 × 30-7/16 × 9-11/32]	299 × 898 × 237 [11-25/32 × 35-23/64 × 9-11/32]		
Net weight		kg [lbs]	11.1 [24.5]	12.9 [28.4]		
Heat exchanger			Cross fin (Aluminum fin and copper tube)			
Fan	Type x Quantity		Line flow fan x 1			
	External static press	Pa	0 (0)			
	Motor type		DC motor			
	Motor output	kW	0.03			
	Driving mechanism		Direct driven			
	Airflow rate (Low-Mid2 -Mid1-High)	m <sup>3</sup> /min	4.3-5.4-6.9-8.4	6.3-7.4-8.6-10.0	6.8-8.3-10.2-12.4	
		L/s	72-90-115-140	105-123-143-167	113-138-170-207	
cfm		152-191-244-297	222-261-304-353	240-293-360-438		
Noise level (Low-Mid2-Mid1-High) (measured in anechoic room)		dB <A>	24-31-37-41	29-34-37-40	31-36-41-46	
Insulation material			Polyethylene sheet			
Air filter			PP Honeycomb			
Protection device			Fuse			
Refrigerant control device			LEV			
Connectable outdoor unit			R454B CITY MULTI			
Diameter of refrigerant pipe	Liquid	mm [in.]	ø6.35 [ø1/4]			
	Gas	mm [in.]	ø12.7 [ø1/2]			
Field drain pipe size		mm [in.]	I.D. 16 [5/8]			
Standard attachment			Installation Manual, Instruction Book			
Optional parts	DRAIN PUMP KIT		PAC-SL48DM-E			
Remark			Details on foundation work, duct work, insulation work, electrical wiring, power source switch, and other items shall be referred to the Installation Manual. Due to continuing improvement, above specifications may be subject to change without notice.			
<b>Notes:</b> *1.Nominal cooling conditions (subject to JIS B8615-1) Indoor: 27°C.D.B./19°C.W.B. (81°F.D.B./66°F.W.B.), Outdoor: 35°C.D.B. (95°F.D.B.) Pipe length: 7.5 m (24-9/16 ft), Level difference: 0 m (0 ft) *2.Nominal heating conditions (subject to JIS B8615-1) Indoor: 20°C.D.B. (68°F.D.B.), Outdoor: 7°C.D.B./6°C.W.B. (45°F.D.B./43°F.W.B.) Pipe length: 7.5 m (24-9/16 ft), Level difference: 0 m (0 ft)						

### 3-2. ELECTRICAL PARTS SPECIFICATIONS

Service ref. Parts name	Symbol	PKFY-L04NLMU-A PKFY-L06NLMU-A PKFY-L08NLMU-A	PKFY-L12NLMU-A PKFY-L15NLMU-A PKFY-L18NLMU-A
Room temperature detection thermistor	TH21	Resistance 32°F/15 kΩ, 50°F/9.6 kΩ, 68°F/6.3 kΩ, 77°F/5.4 kΩ, 86°F/4.3 kΩ, 104°F/3.0 kΩ	
Pipe temperature detection thermistor/liquid	TH22	Resistance 32°F/15 kΩ, 50°F/9.6 kΩ, 68°F/6.3 kΩ, 77°F/5.4 kΩ, 86°F/4.3 kΩ, 104°F/3.0 kΩ	
Pipe temperature detection thermistor/gas	TH23	Resistance 32°F/15 kΩ, 50°F/9.6 kΩ, 68°F/6.3 kΩ, 77°F/5.4 kΩ, 86°F/4.3 kΩ, 104°F/3.0 kΩ	
Fuse (Indoor controller board)	FUSE	T3.15AL250V	
Fan motor (with thermal fuse)	MF	8 × 30W / RC0J30-QD	
Vane motor (Upper)	MV1	NSEK302 DC12V	
Vane motor (Lower)	MV2	MSBPC20 DC12V	
Linear expansion valve	LEV	DC12V Stepping motor drive Port ø3/32 (P04), ø7/64 (P06/08/12/15/18) (0-2000pulse)	
Power supply terminal block	TB2	(L1, L2) Rated to 250V 20A *	
Transmission terminal block	TB5	(M1, M2, S) Rated to 250V 20A *	
MA-Remote controller terminal block	TB15	(1, 2) Rated to 250V 10A *	

\* Refer to WIRING DIAGRAM for the supplied voltage.

NOISE CRITERION CURVES

PKFY-L04NLMU-A

FAN	SPL(dB)	LINE
High	28	○—○
Medium1	26	●—●
Medium2	24	□—□
Low	22	■—■

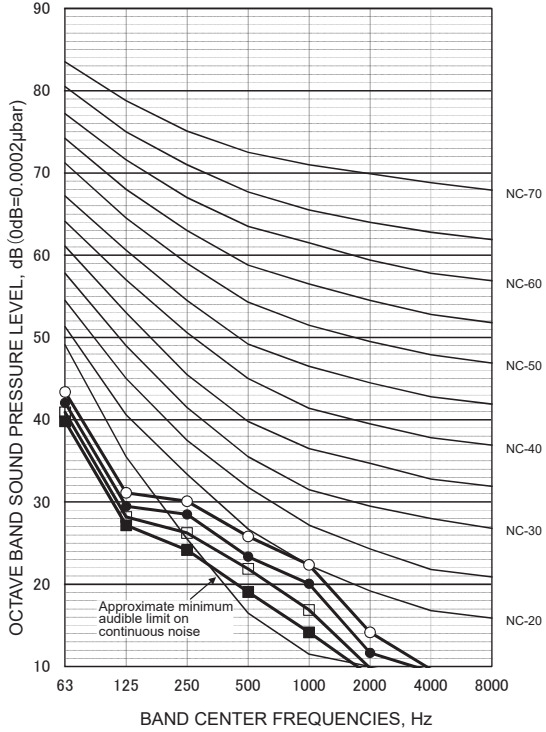

PKFY-L06NLMU-A

FAN	SPL(dB)	LINE
High	31	○—○
Medium1	29	●—●
Medium2	26	□—□
Low	22	■—■

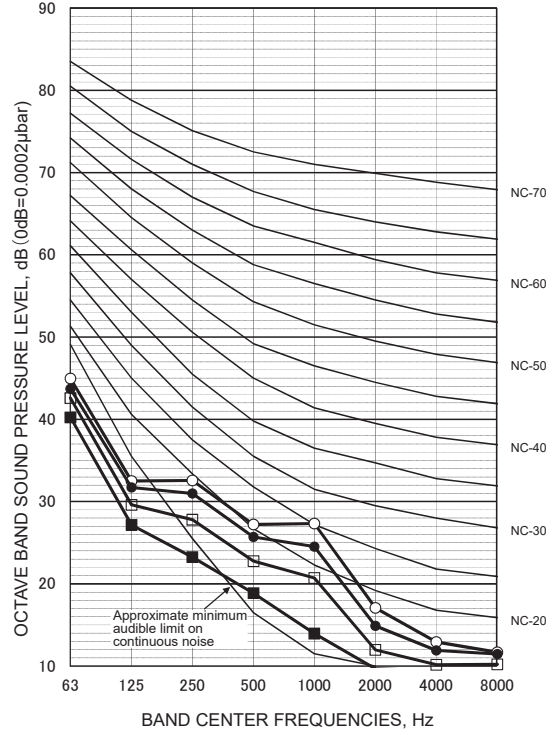

PKFY-L08NLMU-A

FAN	SPL(dB)	LINE
High	35	○—○
Medium1	31	●—●
Medium2	27	□—□
Low	22	■—■

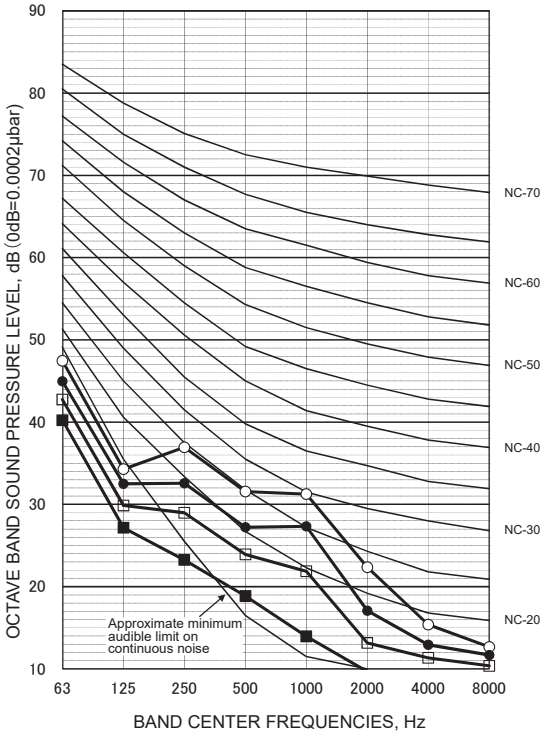

PKFY-L012NLMU-A

FAN	SPL(dB)	LINE
High	41	○—○
Medium1	37	●—●
Medium2	31	□—□
Low	24	■—■

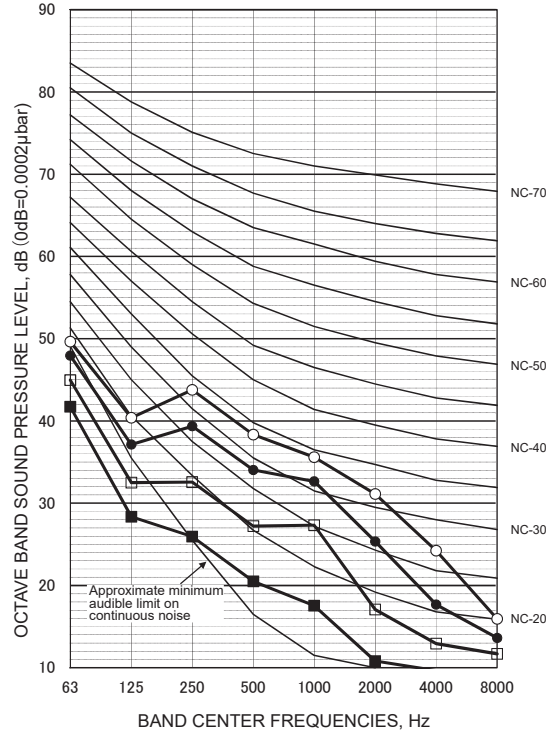

**PKFY-L15NLMU-A**

FAN	SPL(dB)	LINE
High	40	○—○
Medium1	37	●—●
Medium2	34	□—□
Low	29	■—■

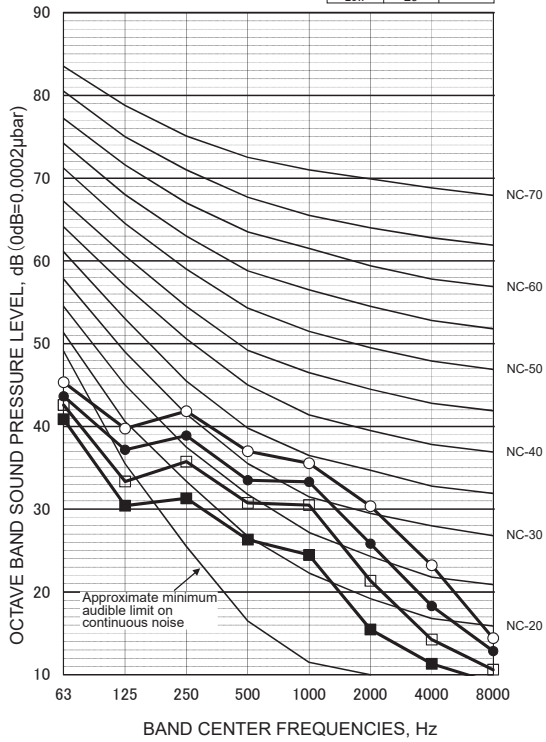

**PKFY-L18NLMU-A**

FAN	SPL(dB)	LINE
High	46	○—○
Medium1	41	●—●
Medium2	36	□—□
Low	31	■—■

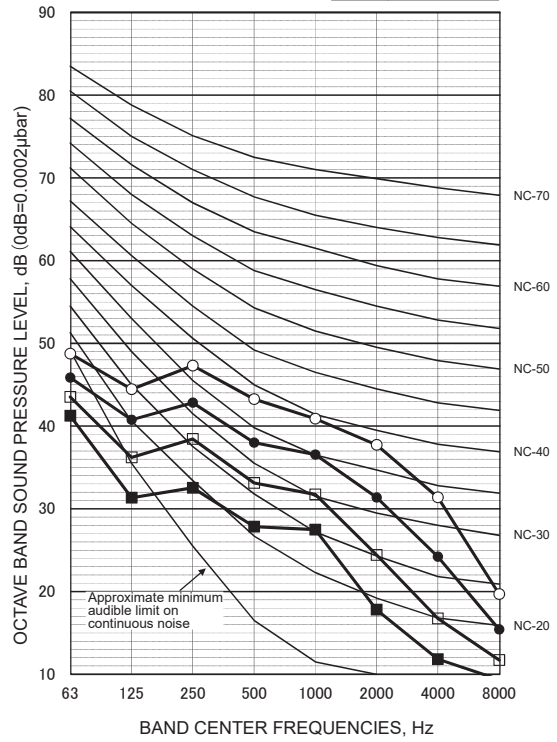





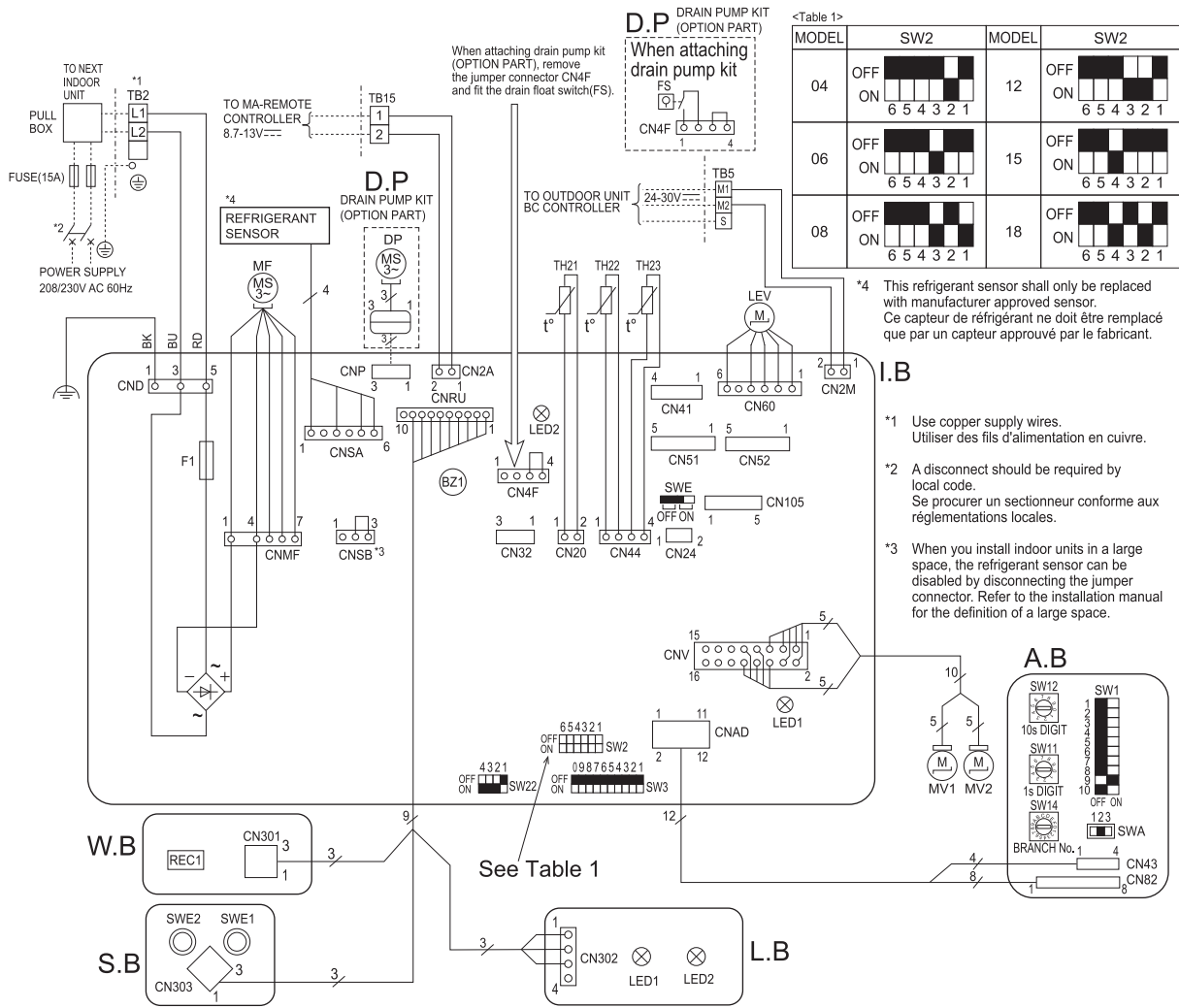

<Table 1>

MODEL	SW2	MODEL	SW2
04	OFF ON 6 5 4 3 2 1	12	OFF ON 6 5 4 3 2 1
06	OFF ON 6 5 4 3 2 1	15	OFF ON 6 5 4 3 2 1
08	OFF ON 6 5 4 3 2 1	18	OFF ON 6 5 4 3 2 1

\*4 This refrigerant sensor shall only be replaced with manufacturer approved sensor.  
Ce capteur de réfrigérant ne doit être remplacé que par un capteur approuvé par le fabricant.

- \*1 Use copper supply wires. Utiliser des fils d'alimentation en cuivre.
- \*2 A disconnect should be required by local code. Se procurer un sectionneur conforme aux réglementations locales.
- \*3 When you install indoor units in a large space, the refrigerant sensor can be disabled by disconnecting the jumper connector. Refer to the installation manual for the definition of a large space.

[LEGND]

SYMBOL	NAME	SYMBOL	NAME
I.B	INDOOR CONTROLLER BOARD	TH21	THERMISTOR
CN24	CONNECTOR	TH22	ROOM TEMP. DETECTION
CN32	EXTERNAL HEATER	TH23	PIPE TEMP. DETECTION/LIQUID
CN51	REMOTE SWITCH		PIPE TEMP. DETECTION/GAS
CN52	CENTRALLY CONTROL		
CN105	REMOTE INDICATION		
	IT TERMINAL	A.B	ADDRESS BOARD
BZ1	BUZZER	SW1	SWITCH
F1	FUSE (T3.15A/250V)	SW11	MODE SELECTION
SW2	SWITCH	SW12	ADDRESS SETTING 1s DIGIT
SW3	CAPACITY CODE	SW14	ADDRESS SETTING 10s DIGIT
SW22	MODE SELECTION		BRANCH No.
SWE	PAIR NO. SETTING	S.B	SWITCH BOARD
	FAN-DRAIN PUMP (TEST MODE)	SWE1	EMERGENCY OPERATION (HEAT)
LEV	LINEAR EXPANSION VALVE	SWE2	EMERGENCY OPERATION (COOL)
MF	FAN MOTOR	W.B	PCB FOR WIRELESS REMOTE CONTROLLER
MV1	VANE MOTOR (UPPER)	REC1	RECEIVING UNIT
MV2	VANE MOTOR (LOWER)	L.B	LED BOARD
TB2	TERMINAL	LED1	LED (OPERATING INDICATOR:GREEN)
TB5	BLOCK	LED2	LED (STANDBY FOR HEATING:ORANGE)
TB15	MA-REMOTE CONTROLLER	D.P	DRAIN PUMP KIT (OPTIONAL PARTS)
		FS	DRAIN FLOAT SWITCH
		DP	DRAIN PUMP

LED on indoor controller board for service

Symbol	Meaning	Function
LED1	Main power supply	Main power supply (Indoor unit:208/230V AC 60Hz) Power on → lamp is lit
LED2	Power supply for MA-Remote controller	Power supply for MA-Remote controller on → lamp is lit

NOTES:

1. At servicing for outdoor unit, always follow the wiring diagram of outdoor unit.
2. In case of using MA-Remote controller, please connect to TB15. (Remote controller wire is non-polar.)
3. In case of using M-NET, please connect to TB5. (Transmission line is non-polar.)
4. Symbol [S] of TB5 is the shield wire connection.
5. Symbols used in wiring diagram are, □:terminal block, □:connector.
6. The setting of the SW2 dip switches differs in the capacity. For the detail, see Table 1.
7. The black square (■) in the wiring diagram indicates a switch position.

# 7

## REFRIGERANT SYSTEM DIAGRAM

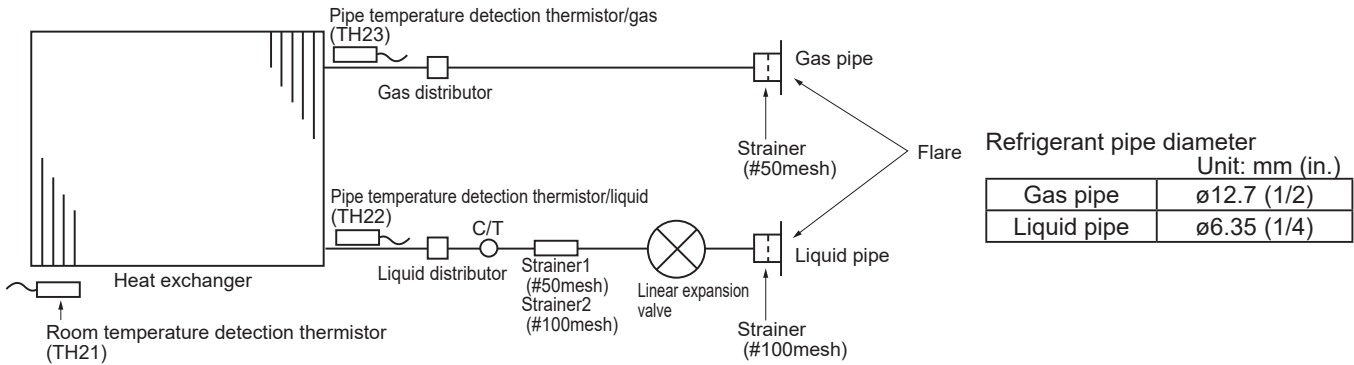

# 8

## MICROPROCESSOR CONTROL

### INDOOR UNIT CONTROL

#### 8-1. COOL OPERATION

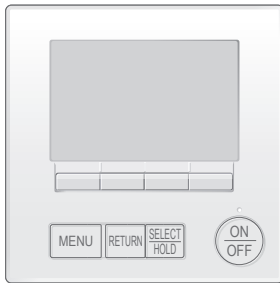

#### <How to operate>

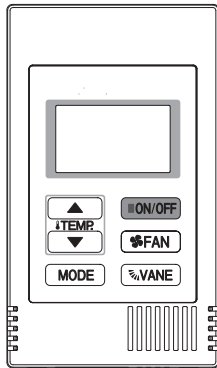

- ① Press ON/OFF button.
- ② Press [F1] button to display COOL.
- ③ Press [F2] [F3] button to set the set temperature.

**NOTE:** The settable temperature range varies with the model of outdoor units and remote controller.



#### <How to operate>

- ① Press POWER ON/OFF button.
- ② Press the operation MODE button to display COOL.
- ③ Press the TEMP. button to set the set temperature.

**NOTE:** The set temperature changes 1°F when the  or  button is pressed one time. Cooling 67 to 87°F

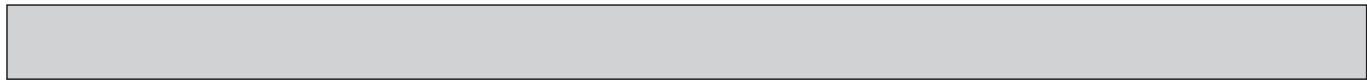

Control Mode	Control Details	Remarks				
1. Temperature adjustment function	<p>1-1. Determining temperature adjustment function (Function to prevent restarting for 3 minutes)</p> <ul style="list-style-type: none"> <li>Room temperature <math>\geq</math> Set temperature + 1°F ...Thermo-ON</li> <li>Room temperature <math>\leq</math> Set temperature - 1°F ...Thermo-OFF</li> </ul> <p>1-2. Anti-freeze control</p> <ul style="list-style-type: none"> <li>Condition to detect When the pipe temperature detection thermistor/liquid (TH22) detects 32°F or less in 16 minutes from thermo-ON, the anti-freeze control initiates, and the unit enters to the thermo-OFF.</li> <li>Condition to release The timer which prevents reactivating is set for 3 minutes, and anti-freeze control is cancelled when any one of the following conditions has been satisfied:               <ol style="list-style-type: none"> <li>Pipe temperature detection thermistor/liquid (TH22) reaches 50°F or above.</li> <li>The condition of thermo-OFF has been completed by the thermostat.</li> <li>The operation has changed to a mode other than COOLING.</li> </ol> </li> </ul>	<ul style="list-style-type: none"> <li>The ON/OFF commands by the indoor unit thermostatic control are not an ON/OFF commands to the compressor but an open/close commands to the linear expansion valve. (The compressor stops only when the thermostatic control for all the indoor units connected to the same outdoor unit turns OFF.)</li> </ul>				
2. Fan	<p>By the remote controller setting (switch of 4 speeds+Auto)</p> <div style="border: 1px solid black; padding: 5px; margin: 10px 0;"> <table style="width: 100%; border-collapse: collapse;"> <thead> <tr> <th style="width: 30%; border: 1px solid black;">Type</th> <th style="border: 1px solid black;">Fan speed notch</th> </tr> </thead> <tbody> <tr> <td style="border: 1px solid black; text-align: center;">4 speeds + Auto type</td> <td style="border: 1px solid black; text-align: center;"> </td> </tr> </tbody> </table> </div> <p>When [Auto] is set, fan speed is changed depending on the value of:  <math>\Delta T = \text{Room temperature} - \text{Set temperature}</math></p> <div style="border: 1px solid black; padding: 5px; margin: 10px 0;"> </div>	Type	Fan speed notch	4 speeds + Auto type		
Type	Fan speed notch					
4 speeds + Auto type						
3. Drain pump	<p>3-1. Drain pump control</p> <ul style="list-style-type: none"> <li>The drain pump will always run when the unit is in COOL or DRYING mode. (Regardless of the thermo ON/OFF)</li> <li>Whenever the operation is changed over to the other modes (including Stop), the drain pump will stop pumping after approximately 3 minutes.</li> </ul> <p><b>Float switch control</b></p> <ul style="list-style-type: none"> <li>Float switch control judges whether the sensor is in the air or in the water by turning the float switch ON/OFF.           <ul style="list-style-type: none"> <li>In the water: Detected that the float switch is ON for 15 seconds.</li> <li>In the air: Detected that the float switch is OFF for 15 seconds</li> </ul> </li> </ul> <div style="margin-top: 10px;"> </div>					
4. Vane (up/down vane change)	<p>(1) The initial vane setting for COOL mode will be the horizontal position.</p> <p>(2) Vane position: Horizontal →Downward A →Downward B →Downward C →Downward D →Swing →Auto</p> <p>(3) Restriction of the downward vane setting If the vane position is set to Downward A/B/C/D in [Med1], [Med2], or [Low], the vane will return to the horizontal position after 1 hour has passed.</p>	<ul style="list-style-type: none"> <li>"1h" appears on the wired remote controller.</li> </ul>				

## 8-2. DRYING OPERATION

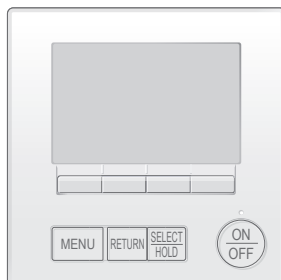

### <How to operate>

- ① Press ON/OFF button.
- ② Press [F1] button to display DRYING.
- ③ Press [F2] [F3] button to set the set temperature.

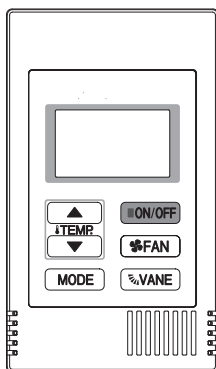

### <How to operate>

- ① Press POWER ON/OFF button.
- ② Press the operation MODE button to display DRYING.
- ③ Press the TEMP. button to set the set temperature.

**NOTE:** The set temperature changes 1°F when the  $\nabla$  or  $\triangle$  button is pressed one time. Dry 67 to 87°F

Control Mode	Control Details	Remarks																														
1. Temperature adjustment function	1-1. Determining temperature adjustment function (Function to prevent restarting for 3 minutes) Setting the Dry thermo by the thermostat signal and the room temperature (TH21). Dry thermo-ON Room temperature $\geq$ Set temperature + 1°F Dry thermo-OFF Room temperature $\leq$ Set temperature - 1°F																															
	<table border="1"> <thead> <tr> <th rowspan="2">Room temperature</th> <th colspan="2">3 minutes passed since starting operation</th> <th rowspan="2">Dry thermo-ON time (min)</th> <th rowspan="2">Dry thermo-OFF time (min)</th> </tr> <tr> <th>Thermostat signal</th> <th>Room temperature (T1)</th> </tr> </thead> <tbody> <tr> <td rowspan="4">Over 64°F</td> <td rowspan="3">ON</td> <td>T1 <math>\geq</math> 83°F</td> <td>9</td> <td>3</td> </tr> <tr> <td>83°F &gt; T1 <math>\geq</math> 79°F</td> <td>7</td> <td>3</td> </tr> <tr> <td>79°F &gt; T1 <math>\geq</math> 75°F</td> <td>5</td> <td>3</td> </tr> <tr> <td>75°F &gt; T1</td> <td>3</td> <td>3</td> </tr> <tr> <td></td> <td>OFF</td> <td>Unconditional</td> <td>3</td> <td>10</td> </tr> <tr> <td>Below 64°F</td> <td colspan="4">Dry thermo OFF</td> </tr> </tbody> </table>	Room temperature	3 minutes passed since starting operation		Dry thermo-ON time (min)	Dry thermo-OFF time (min)	Thermostat signal	Room temperature (T1)	Over 64°F	ON	T1 $\geq$ 83°F	9	3	83°F > T1 $\geq$ 79°F	7	3	79°F > T1 $\geq$ 75°F	5	3	75°F > T1	3	3		OFF	Unconditional	3	10	Below 64°F	Dry thermo OFF			
Room temperature	3 minutes passed since starting operation		Dry thermo-ON time (min)	Dry thermo-OFF time (min)																												
	Thermostat signal	Room temperature (T1)																														
Over 64°F	ON	T1 $\geq$ 83°F	9	3																												
		83°F > T1 $\geq$ 79°F	7	3																												
		79°F > T1 $\geq$ 75°F	5	3																												
	75°F > T1	3	3																													
	OFF	Unconditional	3	10																												
Below 64°F	Dry thermo OFF																															
	1-2. Anti-freeze control No control function																															
2. Fan	Indoor fan operation controlled depends on the compressor conditions. <table border="1"> <thead> <tr> <th>Dry thermo</th> <th colspan="2">Fan speed notch</th> </tr> </thead> <tbody> <tr> <td>ON</td> <td colspan="2">[Low]</td> </tr> <tr> <td rowspan="2">OFF</td> <td>Excluding the following</td> <td>Stop</td> </tr> <tr> <td>Room temp. &lt; 64°F</td> <td>[Low]</td> </tr> </tbody> </table> Note: Fan speed change is not allowed during DRYING operation.	Dry thermo	Fan speed notch		ON	[Low]		OFF	Excluding the following	Stop	Room temp. < 64°F	[Low]																				
Dry thermo	Fan speed notch																															
ON	[Low]																															
OFF	Excluding the following	Stop																														
	Room temp. < 64°F	[Low]																														
3. Drain pump	Operates as it would in COOL operation.																															
4. Vane (up/down vane change)	Settings are the same in DRYING operation as they are in COOL operation.																															

### 8-3. FAN OPERATION

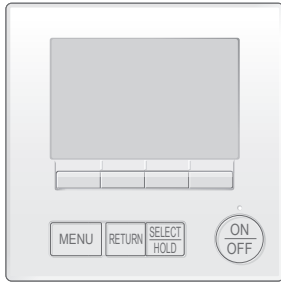

**<How to operate>**

- ① Press ON/OFF button.
- ② Press [F1] button to display FAN.

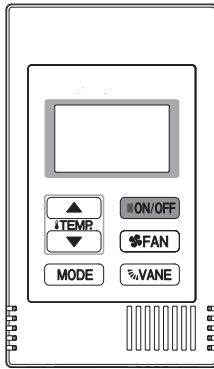

**<How to operate>**

- ① Press POWER ON/OFF button.
- ② Press the operation MODE button to display FAN.

Control Mode	Control Details	Remarks				
1. Temperature adjustment function	<p>Set by remote controller.</p> <table border="1" style="width: 100%;"> <thead> <tr> <th>Type</th> <th>Fan speed notch</th> </tr> </thead> <tbody> <tr> <td>4 speeds + Auto type</td> <td> </td> </tr> </tbody> </table> <p>When [Auto] is set, fan speed becomes [Low].</p>	Type	Fan speed notch	4 speeds + Auto type		
Type	Fan speed notch					
4 speeds + Auto type						
2. Drain pump	<p>2-1. Drain pump control The drain pump turns ON for the specified amount of time when any of the following conditions has been satisfied:</p> <ul style="list-style-type: none"> <li>① ON for 3 minutes after the operation mode is switched from COOL or DRYING to another operation mode (FAN).</li> <li>② ON for 6 minutes after the float switch is submerged in the water when the float switch control judges the sensor is in the water.</li> </ul> <hr/> <p>2-2. Float switch control</p> <ul style="list-style-type: none"> <li>• Float switch control judges whether the sensor is in the air or in the water by turning the float switch ON/OFF.</li> <li>In the water : Detected that the float switch is ON for 15 seconds.</li> <li>In the air : Detected that the float switch is OFF for 15 seconds.</li> </ul>	<ul style="list-style-type: none"> <li>• Operates as it would in COOL operation.</li> </ul>				
3. Vane (up/down vane change)	Same as the control performed during the COOL operation, but with no restriction on the vane's downward blow setting					

## 8-4. HEAT OPERATION

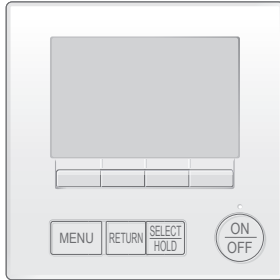

### <How to operate>

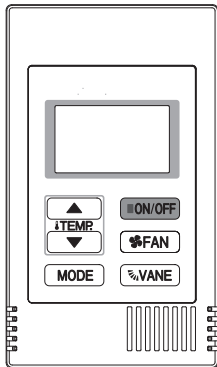

- ① Press ON/OFF button.
- ② Press [F1] button to display HEAT.
- ③ Press [F2] [F3] button to set the set temperature.

**NOTE:** The settable temperature range varies with the model of outdoor units and remote controller.



### <How to operate>

- ① Press POWER ON/OFF button.
- ② Press the operation MODE button to display HEAT.
- ③ Press the TEMP. button to set the set temperature.

**NOTE:** The set temperature changes 1°F when the  or  button is pressed one time. Heating 63 to 83°F

Control Mode	Control Details	Remarks				
1. Temperature adjustment function	1-1. Determining temperature adjustment function (Function to prevent restarting for 3 minutes) <ul style="list-style-type: none"> <li>• Room temperature <math>\leq</math> Set temperature - 1°F ...Thermo-ON</li> <li>• Room temperature <math>\geq</math> Set temperature + 1°F ...Thermo-OFF</li> </ul>					
2. Fan	By the remote controller setting (switch of 4 speeds+Auto) <table border="1" style="margin: 10px auto; width: 80%;"> <thead> <tr> <th>Type</th> <th>Fan speed notch</th> </tr> </thead> <tbody> <tr> <td>4 speeds + Auto type</td> <td> </td> </tr> </tbody> </table> <p>When [Auto] is set, fan speed is changed depending on the value of:  <math>\Delta T = \text{Set temperature} - \text{Room temperature}</math></p> <p>Give priority to under-mentioned controlled mode</p> <p>2-1. Hot adjust mode            2-2. Residual heat exclusion mode            2-3. Thermo-OFF mode (When the compressor off by the temperature adjustment function)            2-4. Cool air prevention mode (Defrosting mode)</p>	Type	Fan speed notch	4 speeds + Auto type		
Type	Fan speed notch					
4 speeds + Auto type						

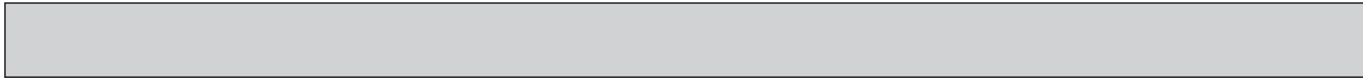

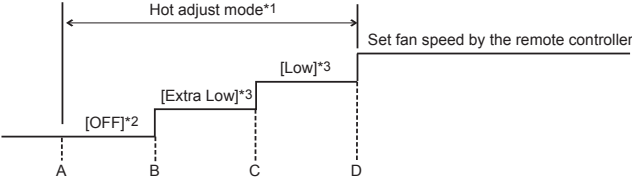
Control Mode	Control Details	Remarks													
	<p>2-1. Hot adjust mode</p> <p>The fan controller becomes the hot adjuster mode for the following conditions.</p> <ol style="list-style-type: none"> <li>① When starting the HEAT operation</li> <li>② When the temperature adjustment function changes from OFF to ON.</li> <li>③ When release the HEAT defrosting operation</li> </ol>  <p>A: Hot adjust mode starts.          B: 5 minutes have passed since the condition A or the indoor liquid pipe temperature reached 86°F or more.          C: 5 minutes have passed since the condition A or the indoor liquid pipe temperature reached 95°F or more.          D: 2minutes have passed since the condition C.          (Terminating the hot adjust mode)</p> <table border="1" data-bbox="884 721 1434 895"> <thead> <tr> <th colspan="2" rowspan="2"></th> <th colspan="2">DIP SW 1-8</th> </tr> <tr> <th>ON</th> <th>OFF</th> </tr> </thead> <tbody> <tr> <th rowspan="2">DIP SW 1-7</th> <th>ON</th> <td>B to C [Extra Low] C to D [Low]</td> <td>B to C [Low] C to D [Low]</td> </tr> <tr> <th>OFF</th> <td>B to C [Setting airflow] C to D [Setting airflow]</td> <td>B to C [Extra Low] C to D [Low] Note: Initial setting</td> </tr> </tbody> </table>			DIP SW 1-8		ON	OFF	DIP SW 1-7	ON	B to C [Extra Low] C to D [Low]	B to C [Low] C to D [Low]	OFF	B to C [Setting airflow] C to D [Setting airflow]	B to C [Extra Low] C to D [Low] Note: Initial setting	<p>*1 "Heat Standby" will be displayed during the hot adjust mode.</p> <p>*2 The step change of A to B will not be performed at the first thermo-ON mode since the HEAT operation has started.</p> <p>*3 The fan speed varies according to the setting of DIP SW1-7 and 1-8 as shown in the table below.</p>
				DIP SW 1-8											
		ON	OFF												
DIP SW 1-7	ON	B to C [Extra Low] C to D [Low]	B to C [Low] C to D [Low]												
	OFF	B to C [Setting airflow] C to D [Setting airflow]	B to C [Extra Low] C to D [Low] Note: Initial setting												
	<p>2-2. Residual heat exclusion mode</p> <p>When the condition changes the auxiliary heater ON to OFF (temperature adjustment function, or operation stop, etc.), the indoor fan operates in [Low] mode for 1 minute.</p>	<p>• This control is same for the model without auxiliary heater.</p>													
	<p>2-3. Thermo-OFF mode</p> <p>When the temperature adjustment function changes to OFF, the indoor fan operates in [Extra low].</p>														
	<p>2-4. Heat defrosting mode</p> <p>The indoor fan stops.</p>														
<p>3. Drain pump</p>	<p>3-1. Drain pump control</p> <p>The drain pump turns ON for the specified amount of time when any of the following conditions has been satisfied:</p> <ol style="list-style-type: none"> <li>① ON for 3 minutes after the operation mode is switched from COOL or DRYING to another operation mode (FAN).</li> <li>② ON for 6 minutes after the float switch is submerged in the water when the float switch control judges the sensor is in the water.</li> </ol> <p>3-2. Float switch control</p> <ul style="list-style-type: none"> <li>• Float switch control judges whether the sensor is in the air or in the water by turning the float switch ON/OFF.</li> </ul> <p>In the water: Detected that the float switch is ON for 15 seconds.          In the air : Detected that the float switch is OFF for 15 seconds.</p>	<p>• Operates as it would in COOL operation.</p>													
<p>4. Vane control (Up/down vane change)</p>	<p>(1) Initial setting: OFF → HEAT…[last setting]          When the last setting is [Swing] … [Downward D]          When changing the mode from exception of HEAT to HEAT operation          …[Downward D]</p> <p>(2) Vane position:          Horizontal →Downward A →Downward B →Downward C→Downward D→Swing→Auto</p> <p>(3) Restriction of vane position</p> <ol style="list-style-type: none"> <li>① The vane is horizontally fixed for the following modes.              (The control by the remote controller is temporarily invalidated and control by the unit.)</li> </ol> <ul style="list-style-type: none"> <li>• Thermo-OFF</li> <li>• Hot adjust [Extra low] mode</li> <li>• Heat defrost mode</li> </ul>														

## 8-5. AUTO OPERATION [AUTOMATIC COOL/HEAT CHANGE OVER OPERATION]

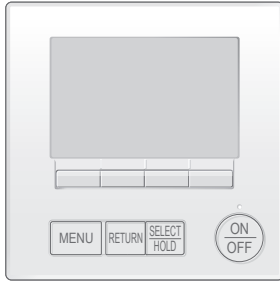

### <How to operate>

- ① Press ON/OFF button.
- ② Press [F1] button to display AUTO.
- ③ Press [F2] [F3] button to set the set temperature.

**NOTE:** The settable temperature range varies with the model of outdoor units and remote controller.

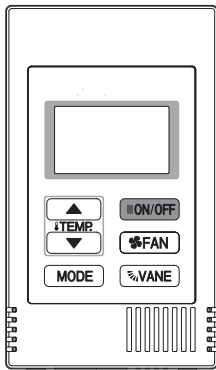

### <How to operate>

- ① Press POWER ON/OFF button.
- ② Press the operation MODE button to display AUTO.
- ③ Press the TEMP. button to set the set temperature.

**NOTE:** The set temperature changes 1°F when the  $\nabla$  or  $\Delta$  button is pressed one time. Automatic 67 to 83°F

Control Mode	Control Details	Remarks
1. Initial value of operation mode	HEAT mode for room temperature < Set temperature COOL mode for room temperature $\geq$ Set temperature	
2. Mode change	(1) HEAT mode $\rightarrow$ COOL mode Room temperature $\leq$ Set temperature + 3°F or 3 minutes have passed. (2) COOL mode $\rightarrow$ HEAT mode Room temperature $\leq$ Set temperature - 3°F or 3 minutes have passed.	
3. COOL mode	Operates as it would in COOL operation.	
4. HEAT mode	Operates as it would in HEAT operation.	

## 8-6. WHEN UNIT IS STOPPED CONTROL MODE

Control Mode	Control Details	Remarks
1. Drain pump	<p>1-1. Drain pump control The drain pump turns ON for the specified amount of time when any of the following conditions has been satisfied:</p> <ol style="list-style-type: none"> <li>① ON for 3 minutes after the operation mode is switched from COOL or DRYING to another operation mode (FAN).</li> <li>② ON for 6 minutes after the float switch is submerged in the water when the float switch control judges the sensor is in the water.</li> </ol> <p>1-2. Float switch control</p> <ul style="list-style-type: none"> <li>• Float switch control judges whether the sensor is in the air or in the water by turning the float switch ON/OFF.</li> <li>In the water : Detected that the float switch is ON for 15 seconds.</li> <li>In the air : Detected that the float switch is OFF for 15 seconds.</li> </ul>	<p>• Operates as it would in COOL operation.</p>

### 9-1. COUNTERMEASURE FOR ERROR DURING TEST RUN

If a problem occurs during test run, a code number will appear on the remote controller (or LED on the outdoor unit), and the air conditioning system will automatically cease operating.

Refer to the connected outdoor unit service manual in order to determine the nature of the abnormality and apply corrective measure.

Check code	Trouble	Detected Unit			Remarks
		Indoor	Outdoor	Remote Controller	
0403	Serial communication error		○		Outdoor unit Multi controller board ~ Power board communication trouble
1102	Compressor temperature		○		Check delay code 1202
1300	Low pressure		○		
1302	High pressure		○		Check delay code 1402
1500	Superheat due to low discharge temperature		○		Check delay code 1600
1501	Refrigerant shortage		○		Check delay code 1601
	Closed valve in cooling mode		○		Check delay code 1501
1503	Freeze protection of branch box or indoor unit		○		
1508	4-way valve trouble in heating mode		○		Check delay code 1608
1521	Refrigerant leakage	○			
1522	Refrigerant leakage or refrigerant sensor error	○			
2500	Water leakage	○			
2502	Drain overflow protection	○			
2503	Drain sensor abnormality	○			
4100	Compressor current interruption (locked compressor)		○		Check delay code 4350
4114	Fan motor error	○			
4210	Compressor overcurrent interruption		○		
4220	Undervoltage/overvoltage/PAM error/L1open phase/power synchronization signal error		○		Check delay code 4320
4230	Heat Sink temperature		○		Check delay code 4330
4250	Power module		○		Check delay code 4350
4400	Fan trouble		○		Check delay code 4500
5101	Air inlet thermistor (TH21) open/short	○			
	Compressor temperature thermistor (TH4) open/short		○		Check delay code 1202
5102	Liquid pipe temperature thermistor (TH22) open/short	○			
	Suction pipe temperature thermistor (TH6) open/short		○		Check delay code 1211
5103	Gas pipe temperature thermistor (TH23) open/short	○			
5105	Outdoor liquid pipe temperature thermistor (TH3) open/short		○		Check delay code 1205
5106	Ambient thermistor (TH7) open/short		○		Check delay code 1221
5109	HIC pipe temperature thermistor (TH2) open/short		○		Check delay code 1222
5110	Heat Sink temperature thermistor (TH8) open/short		○		Check delay code 1214
5201	High pressure sensor (63HS)		○		Check delay code 1402
5202	Low pressure sensor (63LS)		○		Check delay code 1400
5558	Refrigerant sensor error	○			
5701	Contact failure of drain float switch	○			
6600	Duplex address error	○	○	○	Only M-NET Remote controller is detected.
6602	Transmission processor hardware error	○	○	○	Only M-NET Remote controller is detected.
6603	Transmission bus BUSY error	○	○	○	Only M-NET Remote controller is detected.
6606	Signal communication error with transmission processor	○	○	○	Only M-NET Remote controller is detected.
6607	No ACK error	○		○	Only M-NET Remote controller is detected. *
6608	No response frame error	○		○	Only M-NET Remote controller is detected. *
6815	MA supervisor remote controller communication error	○			
6831	MA communication receive error (no receive signal)	○		○	Only MA Remote controller is detected.
6832	MA communication send error	○		○	Only MA Remote controller is detected.
6833	MA communication send error	○		○	Only MA Remote controller is detected.
6834	MA communication receive error	○		○	Only MA Remote controller is detected.
7100	Total capacity error		○		
7101	Capacity code error	○	○		
7102	Connecting excessive number of units		○		
7105	Address setting error		○		
7118	Refrigerant leak detection system error		○		
7123	Alarm Kit connection error	○	○		
7130	Incompatible unit combination		○		

Note:

When the outdoor unit detects No ACK error/No response error, an object indoor unit is treated as a stop, and not assumed to be abnormal.

## 9-2. HOW TO CHECK THE PARTS

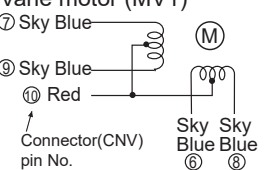
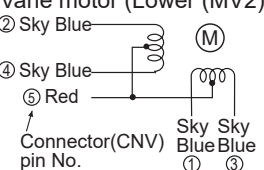
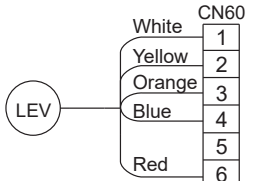
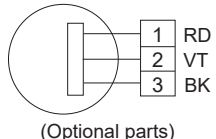
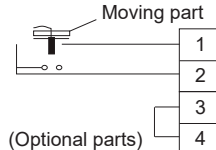
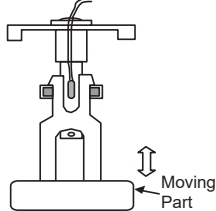
Parts name	Checkpoints																
Room temperature detection thermistor (TH21) Pipe temperature detection thermistor/liquid (TH22) Pipe temperature detection thermistor/gas (TH23)	Disconnect the connector then measure the resistance with a multimeter. (At the ambient temperature 50 to 86°F) <table border="1" style="margin-top: 10px;"> <tr> <td style="text-align: center;">Normal</td> <td rowspan="2" style="vertical-align: middle;">Refer to "9-2-1. Thermistor".</td> </tr> <tr> <td style="text-align: center;">4.3 to 9.6 kΩ</td> </tr> </table>	Normal	Refer to "9-2-1. Thermistor".	4.3 to 9.6 kΩ													
Normal	Refer to "9-2-1. Thermistor".																
4.3 to 9.6 kΩ																	
Vane motor (MV1) 	Measure the resistance between the terminals with a multimeter. (At the ambient temperature 77°F) <table border="1" style="margin-top: 10px;"> <tr> <th colspan="4" style="text-align: center;">Normal</th> </tr> <tr> <td style="text-align: center;">⑩ - ⑨ Red-Sky Blue</td> <td style="text-align: center;">⑩ - ⑧ Red-Sky Blue</td> <td style="text-align: center;">⑩ - ⑦ Red-Sky Blue</td> <td style="text-align: center;">⑩ - ⑥ Red-Sky Blue</td> </tr> <tr> <td colspan="4" style="text-align: center;">300 Ω±7%</td> </tr> </table>	Normal				⑩ - ⑨ Red-Sky Blue	⑩ - ⑧ Red-Sky Blue	⑩ - ⑦ Red-Sky Blue	⑩ - ⑥ Red-Sky Blue	300 Ω±7%							
Normal																	
⑩ - ⑨ Red-Sky Blue	⑩ - ⑧ Red-Sky Blue	⑩ - ⑦ Red-Sky Blue	⑩ - ⑥ Red-Sky Blue														
300 Ω±7%																	
Vane motor (Lower (MV2)) 	Measure the resistance between the terminals with a multimeter. (At the ambient temperature 77°F) <table border="1" style="margin-top: 10px;"> <tr> <th colspan="4" style="text-align: center;">Normal</th> </tr> <tr> <td style="text-align: center;">⑤ - ④ Red-Sky Blue</td> <td style="text-align: center;">⑤ - ③ Red-Sky Blue</td> <td style="text-align: center;">⑤ - ② Red-Sky Blue</td> <td style="text-align: center;">⑤ - ① Red-Sky Blue</td> </tr> <tr> <td colspan="4" style="text-align: center;">300±26.3 Ω</td> </tr> </table>	Normal				⑤ - ④ Red-Sky Blue	⑤ - ③ Red-Sky Blue	⑤ - ② Red-Sky Blue	⑤ - ① Red-Sky Blue	300±26.3 Ω							
Normal																	
⑤ - ④ Red-Sky Blue	⑤ - ③ Red-Sky Blue	⑤ - ② Red-Sky Blue	⑤ - ① Red-Sky Blue														
300±26.3 Ω																	
Fan motor (MF)	Refer to "9-2-3. DC Fan motor (fan motor/indoor controller board)"																
Linear expansion valve (LEV) 	Disconnect the connector then measure the resistance valve with a multimeter. (Coil temperature 68°F) <table border="1" style="margin-top: 10px;"> <tr> <th colspan="4" style="text-align: center;">Normal</th> </tr> <tr> <td style="text-align: center;">(1)-(5) White-Red</td> <td style="text-align: center;">(2)-(6) Yellow-Red</td> <td style="text-align: center;">(3)-(5) Orange-Red</td> <td style="text-align: center;">(4)-(6) Blue-Red</td> </tr> <tr> <td colspan="4" style="text-align: center;">150 Ω±10%</td> </tr> </table>	Normal				(1)-(5) White-Red	(2)-(6) Yellow-Red	(3)-(5) Orange-Red	(4)-(6) Blue-Red	150 Ω±10%							
Normal																	
(1)-(5) White-Red	(2)-(6) Yellow-Red	(3)-(5) Orange-Red	(4)-(6) Blue-Red														
150 Ω±10%																	
Drain pump (DP)  (Optional parts)	<ol style="list-style-type: none"> <li>① Check if the drain float switch works properly.</li> <li>② Check if the drain pump works and drains water properly in cooling operation.</li> <li>③ If no water drains, confirm that the check code 2502 will not be displayed 10 minutes after the operation starts.</li> </ol> <p>Note: The drain pump for this model is driven by the internal DC motor, so it is not possible to measure the resistance between the terminals.</p> <p>Normal: Red-Black: Input 13 V DC → The pump motor starts to rotate.</p>																
Drain float switch (FS)  (Optional parts)	Measure the resistance between the terminals with a multimeter. <table border="1" style="margin-top: 10px;"> <thead> <tr> <th>State of moving part</th> <th>Normal</th> <th>Abnormal</th> <th>Drain float switch connector terminal</th> </tr> </thead> <tbody> <tr> <td style="text-align: center;">UP</td> <td style="text-align: center;">Short</td> <td style="text-align: center;">Other than short</td> <td style="text-align: center;">①(+)-②(-)</td> </tr> <tr> <td style="text-align: center;">DOWN</td> <td style="text-align: center;">Open</td> <td style="text-align: center;">Other than open</td> <td style="text-align: center;">①(+)-②(-)</td> </tr> <tr> <td style="text-align: center;">-</td> <td style="text-align: center;">Short</td> <td style="text-align: center;">Other than short</td> <td style="text-align: center;">③(+)-④(-)</td> </tr> </tbody> </table> 	State of moving part	Normal	Abnormal	Drain float switch connector terminal	UP	Short	Other than short	①(+)-②(-)	DOWN	Open	Other than open	①(+)-②(-)	-	Short	Other than short	③(+)-④(-)
State of moving part	Normal	Abnormal	Drain float switch connector terminal														
UP	Short	Other than short	①(+)-②(-)														
DOWN	Open	Other than open	①(+)-②(-)														
-	Short	Other than short	③(+)-④(-)														

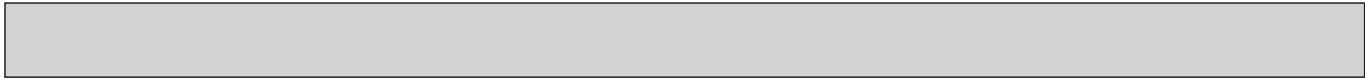

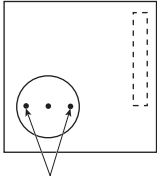
Parts name	Checkpoint				
Refrigerant sensor	Measure the resistance between the terminals with a multimeter.				
	<table border="1"> <thead> <tr> <th>Normal</th> <th>Abnormal</th> </tr> </thead> <tbody> <tr> <td>Below 10 Ω</td> <td>Open (10 Ω or more)</td> </tr> </tbody> </table>	Normal	Abnormal	Below 10 Ω	Open (10 Ω or more)
	Normal	Abnormal			
Below 10 Ω	Open (10 Ω or more)				
<p>After turning off the indoor unit breaker and leaving it for 5 minutes, measure the resistance value between the sensor terminals. &lt; Back side of the sensor &gt;</p>  <p>Measure the both sides of the sensor pin.</p>					

### 9-2-1. Thermistor

<Thermistor characteristic graph>

Thermistors for lower temperature

- Room temperature detection thermistor (TH21)
- Pipe temperature detection thermistor/liquid (TH22)
- Pipe temperature detection thermistor/gas (TH23)

Thermistor  $R_0=15\text{ k}\Omega \pm 3\%$   
Fixed number of  $B=3480 \pm 2\%$

$$R_t = 15 \exp \left\{ 3480 \left( \frac{1}{273 + (t-32)/1.8} - \frac{1}{273} \right) \right\}$$

30°F	15.8 kΩ
50°F	9.6 kΩ
70°F	6.0 kΩ
80°F	4.8 kΩ
90°F	3.9 kΩ
100°F	3.2 kΩ

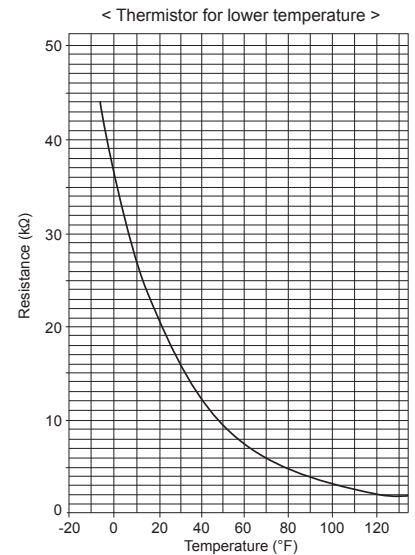

### 9-2-2. Linear expansion valve

#### ① Operation summary of the linear expansion valve

- Linear expansion valve opens/closes through stepping motor after receiving the pulse signal from the indoor controller board.
- Valve position can be changed in proportion to the number of pulse signal.

<Connection between the indoor controller board and the linear expansion valve>

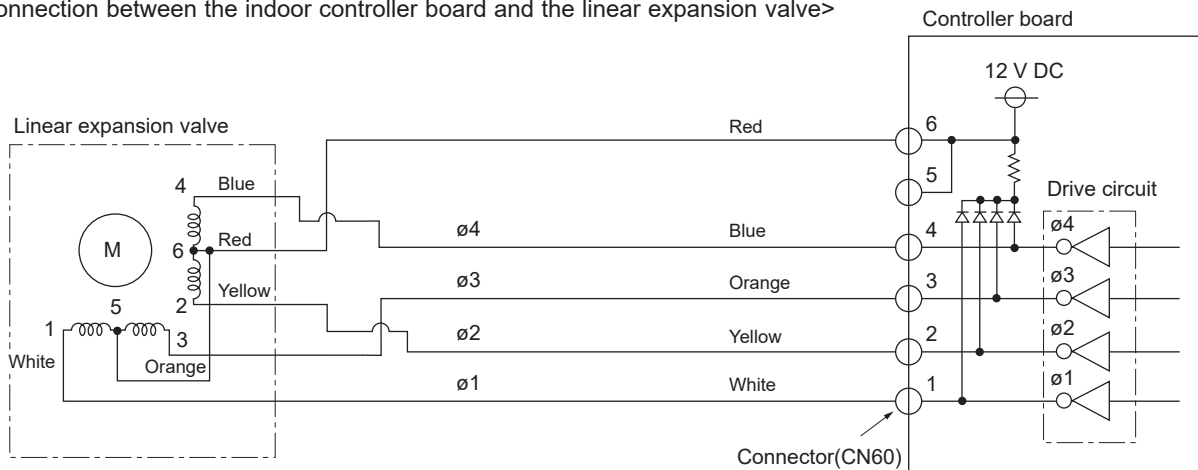

Note : Since the number of the connector at the controller board side and the relay connector are different, follow the color of the lead wire.

### 9-2-3. DC Fan motor (fan motor/indoor controller board)

Check method of indoor fan motor (fan motor/indoor controller board)

① Notes

- High voltage is applied to the connector (CNMF) for the fan motor. Pay attention to the service.
- Do not pull out the connector (CNMF) for the motor with the power supply on.  
(It causes trouble of the indoor controller board and fan motor.)

② Self check

Conditions : The indoor fan cannot rotate.

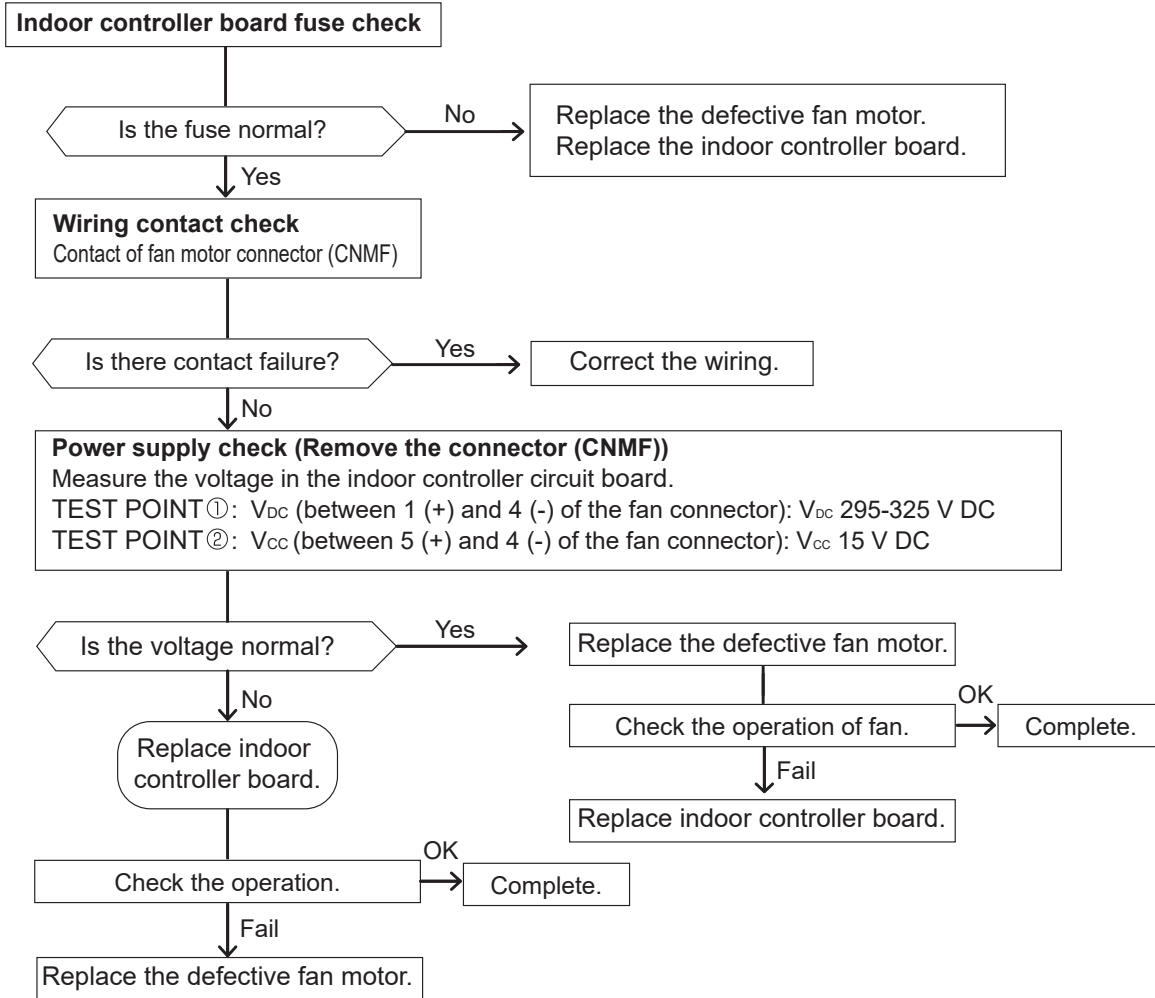

### <Output pulse signal and the valve operation>

Output (Phase)	Output			
	1	2	3	4
ø1	ON	OFF	OFF	ON
ø2	ON	ON	OFF	OFF
ø3	OFF	ON	ON	OFF
ø4	OFF	OFF	ON	ON

The output pulse shifts in below order.  
 Closing a valve : 1 → 2 → 3 → 4 → 1  
 Opening a valve : 4 → 3 → 2 → 1 → 4

- When linear expansion valve operation stops, all output phase become OFF.
- At phase interruption or when phase does not shift in order, motor does not rotate smoothly and motor will lock and vibrate.

### ② Linear expansion valve operation

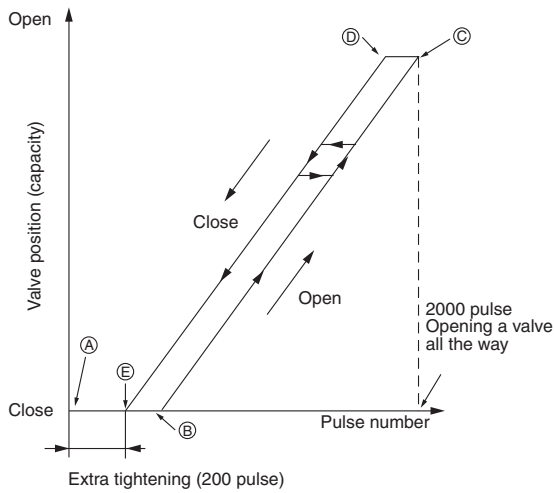

- When the power is turned on, 2200 pulse closing valve signal will be sent till it goes to point A in order to define the valve position.
- When the valve moves smoothly, there is no noise or vibration occurring from the linear expansion valves : however, when the pulse number moves from E to A or when the valve is locked, more noise can be heard than in a normal situation.
- Noise can be detected by placing the ear against the screw driver handle while putting the screw driver tip to the linear expansion valve.

### ③ Troubleshooting

Symptom	Check points	Countermeasures
Operation circuit failure of the micro-processor	Disconnect the connector on the controller board, then connect LED for checking.  1kΩ LED	Exchange the indoor controller board at drive circuit failure.
Linear expansion valve mechanism is locked.	Motor will idle and make a ticking noise when the motor is operated while the linear expansion valve is locked. This ticking sound is the sign of the abnormality.	Exchange the linear expansion valve.
Short or breakage of the motor coil of the linear expansion valve	Measure the resistance between each coil (white-red, yellow-red, orange-red, blue-red) using a multimeter. It is normal if the resistance is in the range of 150 Ω ±10%.	Exchange the linear expansion valve.
Valve does not close completely.	To check the linear expansion valve, operate the indoor unit in fan mode and at the same time operate other indoor units in cooling mode, then check the pipe temperature <liquid pipe temperature> of the indoor unit by the outdoor multi controller board operation monitor. During fan operation, linear expansion valve is closed completely and if there is any leaking, detecting temperature of the thermistor will go lower. If the detected temperature is much lower than the temperature indicated in the remote controller, it means the valve is not closed all the way. It is not necessary to exchange the linear expansion valve, if the leakage is small and not affecting normal operation.  Thermistor (Liquid pipe) Linear expansion valve	If large amount of refrigerant is leaked, exchange the linear expansion valve.
Wrong connection of the connector or contact failure	Check the color of lead wire and missing terminal of the connector.	Disconnect the connector at the controller board, then check the continuity.

## 9-2-4. Refrigerant sensor

Check code

1521/1522  
(FL)

# Refrigerant leakage

Abnormal points and detection methods	Causes and checkpoints
Refrigerant is leaking from the air conditioner. The refrigerant sensor has detected refrigerant leak. Refrigerant is leaking in the room where the alarm is beeping. (Optional) A refrigerant sensor has failed.	<ul style="list-style-type: none"> <li>• Refrigerant leak from air conditioner</li> <li>• Refrigerant leak from piping</li> <li>• False detection (The refrigerant sensor reacted to other gas.)</li> </ul>

### Notes:

- When this error occurs, both of the alarm in the applicable room and the supervisor mode alarm beep. Also, the system closes the shut-off valve and performs refrigerant recovery.
- When this error occurs, ventilate the room.
- When this error occurs, do not turn off the power until the fan in the outdoor unit stops.

### Diagnosis of failure

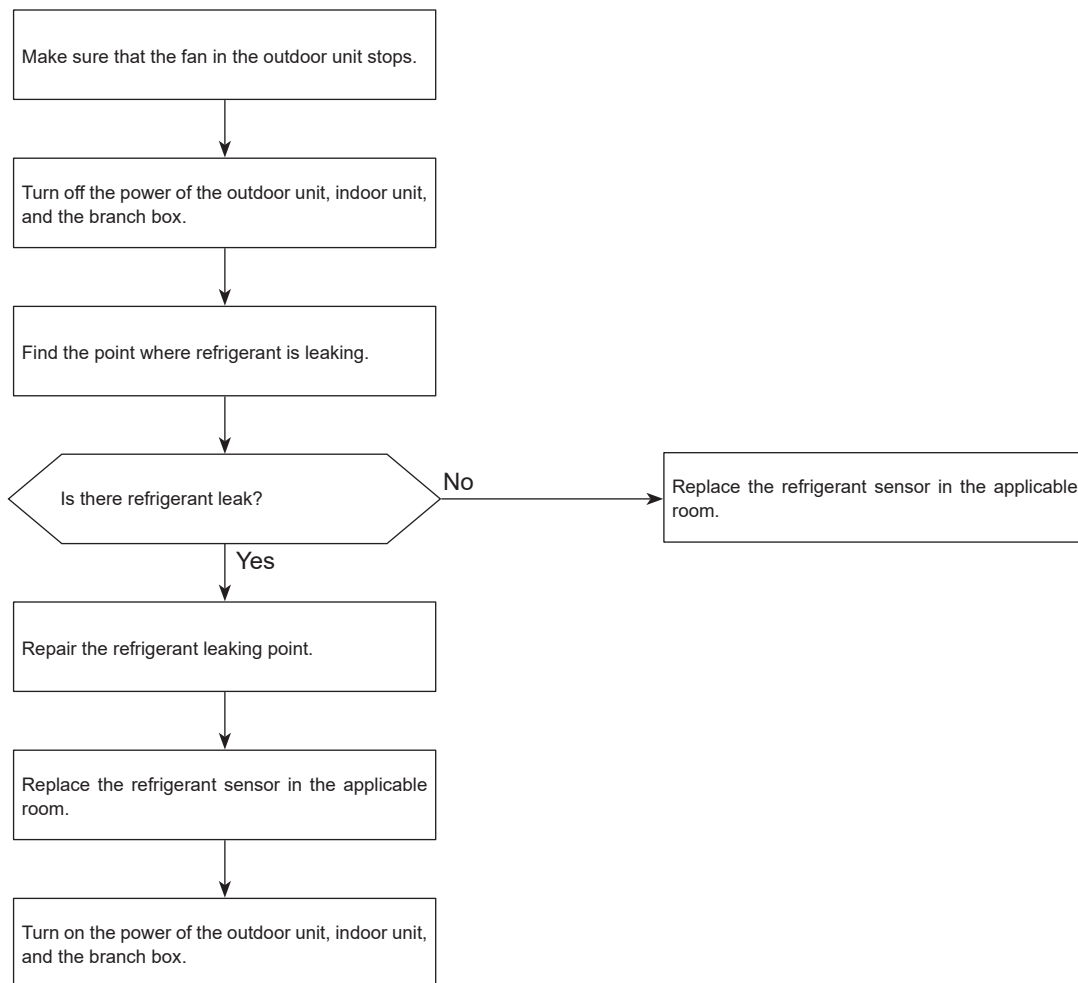

## Refrigerant sensor error





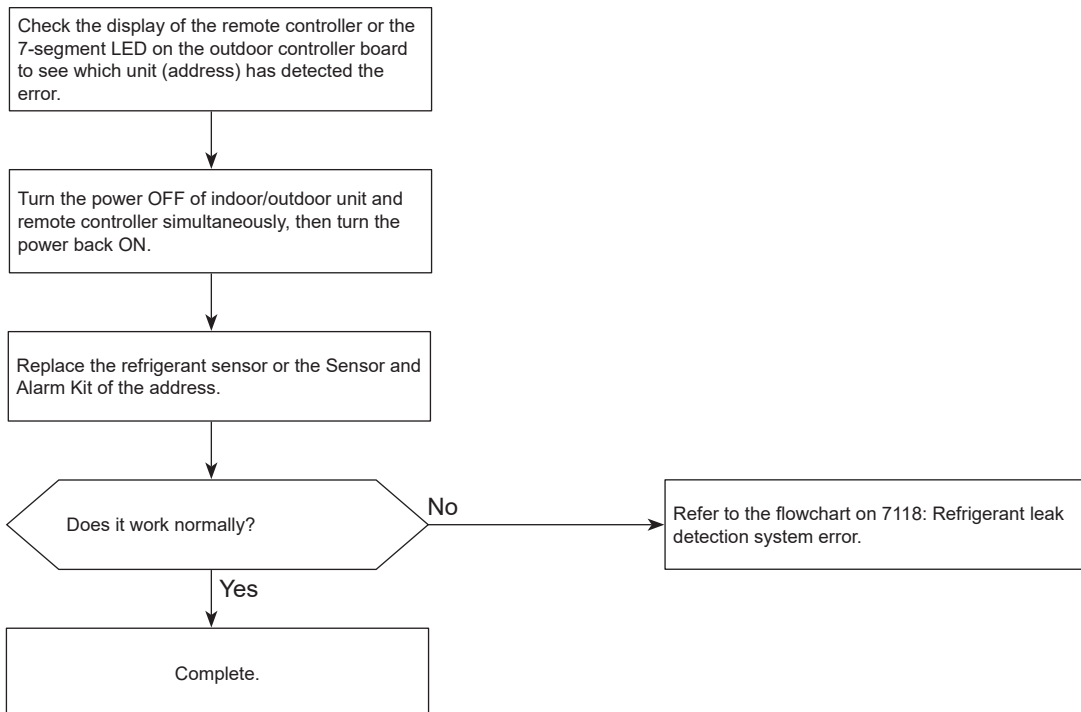





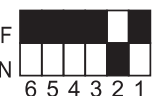
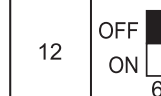



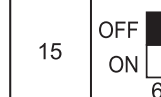

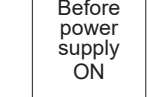

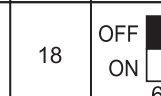

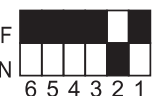
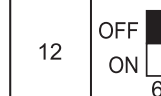



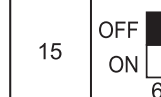

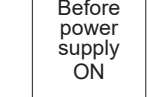

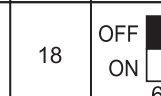

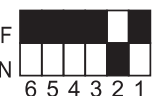
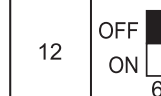

Abnormal points and detection methods	Causes and checkpoints
A refrigerant sensor has failed.	<ul style="list-style-type: none"> <li>• A refrigerant sensor connected to an M-IC has failed.</li> <li>• A Sensor and Alarm Kit connected to a branch box has failed.</li> </ul>

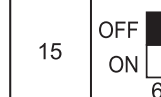
## Diagnosis of failure

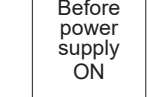

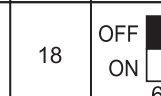
### 9-3. FUNCTION OF DIP SWITCH







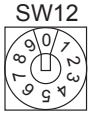
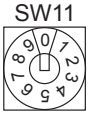
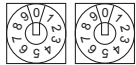
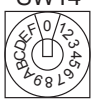

The black square (■) indicates a switch position.

Switch	Pole	Function	Operation by switch		Effective timing	Remarks														
			ON	OFF																
SW1 Mode Selection	1	Thermistor <Intake temperature detection> position	Built-in remote controller	Indoor unit	Under suspension	<div style="border: 1px solid black; padding: 2px; text-align: center;">Address board</div> <p>&lt;Initial setting&gt;</p>  <p>*1 The model is not capable of fresh air intake. *2 Refer to &lt;Table A&gt; below.</p>														
	2	Filter clogging	Provided	Not provided																
	3	Filter sign indication	2,500 hr	100 hr																
	4	Air intake*1	Not effective	Not effective																
	5	Remote indication switching	Thermo-ON signal indication	Fan output indication																
	6	Humidifier control	Fan operation at Heating mode	Thermo-ON operation at heating mode																
	7	Air flow set in case of heat thermo-OFF	Low*2	Extra low*2																
	8		Setting air flow*1	Depends on SW1-7																
	9	Auto restart function	Effective	Not effective																
	10	Power ON/OFF	Effective	Not effective																
SW2 Capacity code setting	1-4	<table border="1" style="width: 100%; text-align: center;"> <thead> <tr> <th>Models</th> <th>SW2</th> <th>Models</th> <th>SW2</th> </tr> </thead> <tbody> <tr> <td>04</td> <td>           OFF             ON  </td> <td>12</td> <td>           OFF             ON  </td> </tr> <tr> <td>06</td> <td>           OFF             ON  </td> <td>15</td> <td>           OFF             ON  </td> </tr> <tr> <td>08</td> <td>           OFF             ON  </td> <td>18</td> <td>           OFF             ON  </td> </tr> </tbody> </table>	Models	SW2	Models	SW2	04	OFF  ON 	12	OFF  ON 	06	OFF  ON 	15	OFF  ON 	08	OFF  ON 	18	OFF  ON 	Before power supply ON	<div style="border: 1px solid black; padding: 2px; text-align: center;">Indoor controller board</div> <p>&lt;Initial setting&gt; Set for each capacity.</p>
		Models	SW2	Models	SW2															
		04	OFF  ON 	12	OFF  ON 															
		06	OFF  ON 	15	OFF  ON 															
08	OFF  ON 	18	OFF  ON 																	
1	Heat pump/Cool only	Cooling only	Heat pump	Under suspension	<div style="border: 1px solid black; padding: 2px; text-align: center;">Indoor controller board</div> <p>&lt;Initial setting&gt;</p> 															
2	—	—	—																	
3	—	—	—																	
4	—	—	—																	
5	—	—	—																	
6	—	—	—																	
7	Changing the opening of linear expansion valve	Effective	Not effective																	
8	Heating 4 degree up	Not effective	Effective																	
9	—	—	—																	
10	—	—	—																	

<Table A>

SW1-7	SW1-8	
OFF	OFF	Extra low
ON	OFF	Low
OFF	ON	Setting air flow
ON	ON	stop

The black square (■) indicates a switch position.

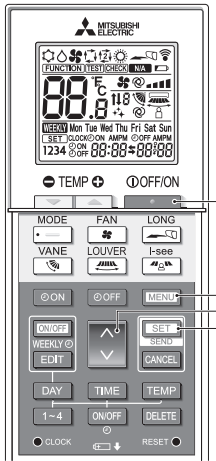
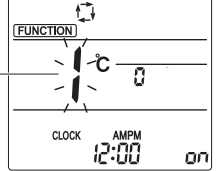
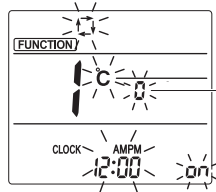
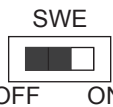
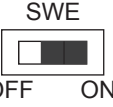
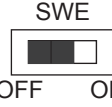
Switch	Pole	Function	Effective timing	Remarks																																								
SW11 1s digit address setting  SW12 10s digit address setting	Rotary switch	  10      1 Address setting should be done when M-NET remote controller is being used.	Before power supply ON	<div style="border: 1px solid black; padding: 5px; text-align: center;">Address board</div> <Initial setting> SW12    SW11 																																								
SW14 Connection No. setting	Rotary switch	 SW14 This is the switch to be used when the indoor unit is operated with R2 series outdoor unit as a set.		<div style="border: 1px solid black; padding: 5px; text-align: center;">Address board</div> <Initial setting> SW14 																																								
SW22 Function selection	Jumper	<table border="1" style="width: 100%; text-align: center;"> <thead> <tr> <th></th> <th>Function</th> <th>ON</th> <th>OFF</th> </tr> </thead> <tbody> <tr> <td>1</td> <td>—</td> <td>—</td> <td>—</td> </tr> <tr> <td>2</td> <td>—</td> <td>—</td> <td>—</td> </tr> <tr> <td>3</td> <td>Pair No. of wireless remote controller</td> <td colspan="2" rowspan="2">Depends on SW22-3, 22-4</td> </tr> <tr> <td>4</td> <td>Pair No. of wireless remote controller</td> </tr> </tbody> </table> <ul style="list-style-type: none"> <li>To operate each indoor unit by each remote controller when installed 2 indoor units or more are near, Pair No. setting is necessary.               <ul style="list-style-type: none"> <li>Pair No. setting is available with the 4 patterns (Setting patterns A to D).</li> </ul> </li> <li>You may not set it when operating it by one remote controller. Setting for indoor unit.</li> </ul> <p>Wireless remote controller pair number:</p> <ul style="list-style-type: none"> <li>Setting operation (Fig. 1 (A))               <ol style="list-style-type: none"> <li>Press the  button ① to stop the air conditioner.</li> <li>Press the  button ②.</li> <li>Check that function No."1" is displayed, and then press the  button ③. The Screen display setting screen will be displayed. (Fig. 2.)</li> </ol> </li> <li>Pair No. changing operation (Fig. 2 (B))               <ol style="list-style-type: none"> <li>Press the  button ④.</li> <li>Each time the  button ④ is pressed, the pair No.0-3 changes.</li> <li>Press the  button ③ to check the setting.</li> <li>Press the  button ③.</li> </ol> </li> </ul> <table border="1" style="width: 100%; text-align: center;"> <thead> <tr> <th colspan="2">Indoor unit SW22</th> <th rowspan="2">Pair No. of wireless remote controller</th> <th rowspan="2"></th> </tr> <tr> <th>SW22-3</th> <th>SW22-4</th> </tr> </thead> <tbody> <tr> <td>ON</td> <td>ON</td> <td>0</td> <td>Initial setting</td> </tr> <tr> <td>OFF</td> <td>ON</td> <td>1</td> <td>—</td> </tr> <tr> <td>ON</td> <td>OFF</td> <td>2</td> <td>—</td> </tr> <tr> <td>OFF</td> <td>OFF</td> <td>3-9</td> <td>—</td> </tr> </tbody> </table>		Function	ON	OFF	1	—	—	—	2	—	—	—	3	Pair No. of wireless remote controller	Depends on SW22-3, 22-4		4	Pair No. of wireless remote controller	Indoor unit SW22		Pair No. of wireless remote controller		SW22-3	SW22-4	ON	ON	0	Initial setting	OFF	ON	1	—	ON	OFF	2	—	OFF	OFF	3-9	—	Under operation or suspension	<Initial setting>   <b>Fig. 1</b>  <b>Fig. 2</b>
	Function	ON	OFF																																									
1	—	—	—																																									
2	—	—	—																																									
3	Pair No. of wireless remote controller	Depends on SW22-3, 22-4																																										
4	Pair No. of wireless remote controller																																											
Indoor unit SW22		Pair No. of wireless remote controller																																										
SW22-3	SW22-4																																											
ON	ON	0	Initial setting																																									
OFF	ON	1	—																																									
ON	OFF	2	—																																									
OFF	OFF	3-9	—																																									
SWE Test run for Drain pump	Connector	  OFF    ON                      OFF    ON The connector SWE is set to OFF after test run.	Under operation	<Initial setting>  OFF    ON																																								

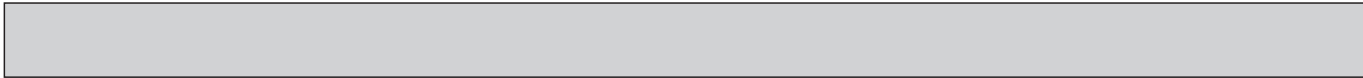

Switch	Pole	Function	Effective timing	Remarks	
CNSB Activation switch for CNSA refrigerant sensor	Short-circuit connector	It is to enable/disable the refrigerant sensor mounted to the indoor unit. If the indoor unit is installed in a large space, remove the short-circuit connector.		<Initial setting> Short-circuit connector mounted	
		Short-circuit connector	Refrigerant sensor mounted to the indoor unit		
		Yes	Activated		
		No	Deactivated		
External heater Switching the external heater output	Function setting	It is to switch permission/prohibition of the external heater output when the refrigerant sensor is in the abnormal state. Refer to the operation manual included in the remote controller for the setting.			
		Function setting No.171	External heater operation		Remarks
		1	Permission		
		2	Prohibition		Initial setting
15	Initializing this item				

## 9-4. TEST POINT DIAGRAM

### 9-4-1. Indoor controller board (I.B)

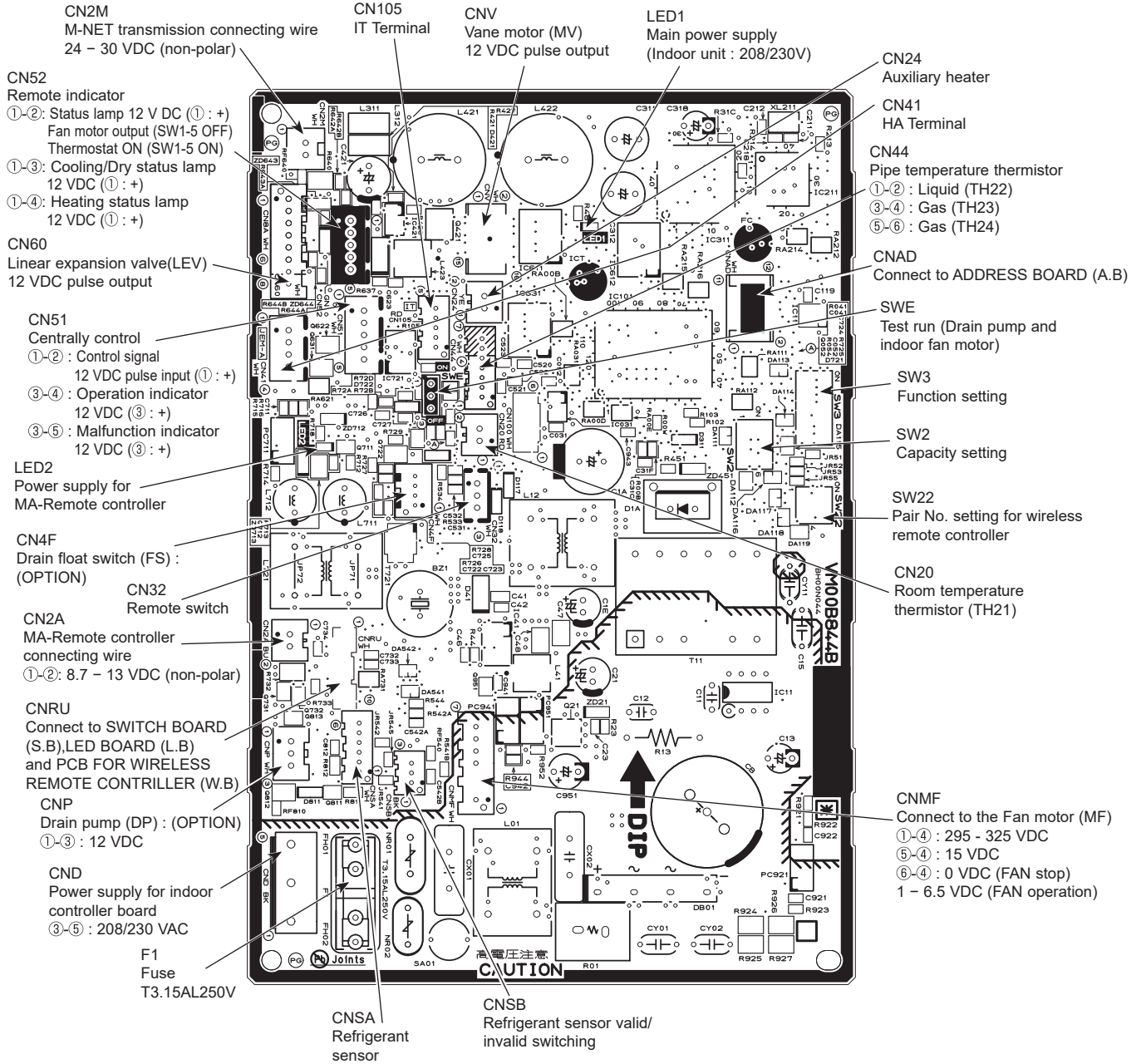

Note: The voltage range of 12 VDC in this page is between 11.5 to 13.7 VDC.

### 9-4-2. PCB FOR WIRELESS REMOTE CONTROLLER (W.B), SWITCH BOARD (S.B) and LED BOARD (L.B)

**PCB FOR WIRELESS REMOTE CONTROLLER (W.B)**

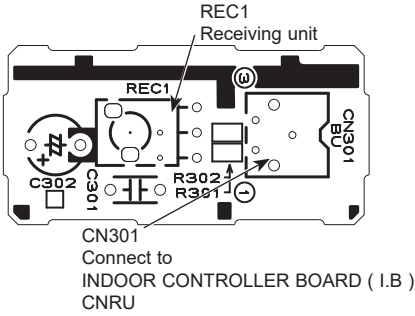

**SWITCH BOARD (S.B)**

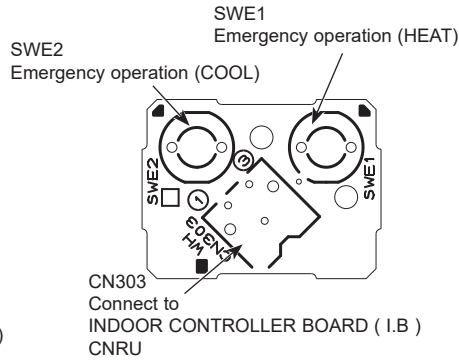

**LED BOARD (L.B)**

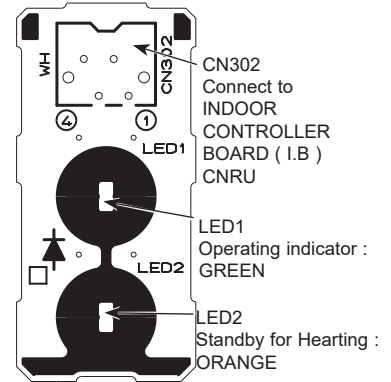

### 9-4-3. Address board (A.B)

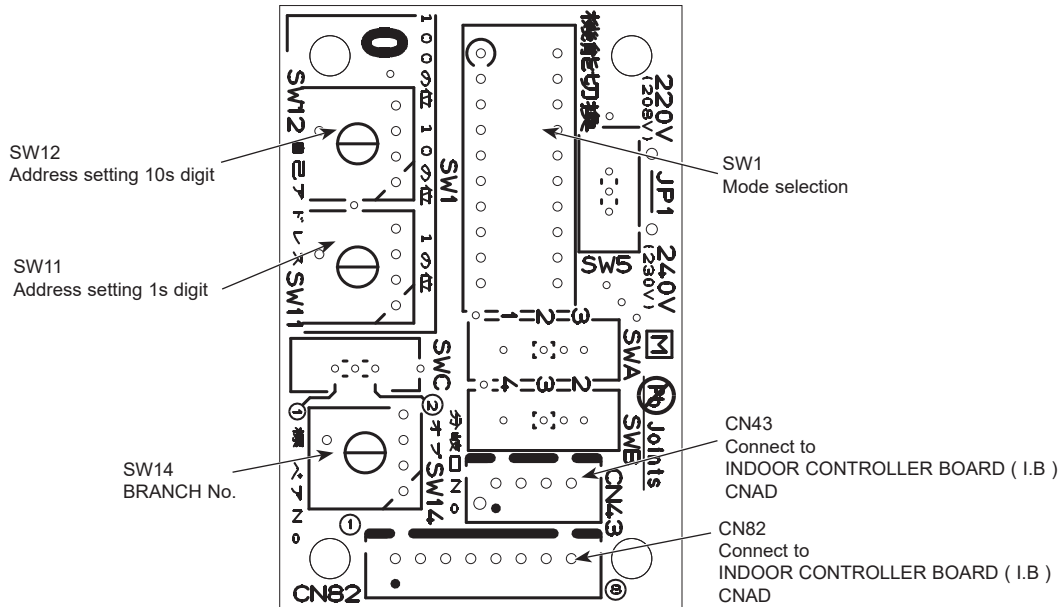

NOTE: Turn OFF the power supply before disassembly.  
Be careful when removing heavy parts.

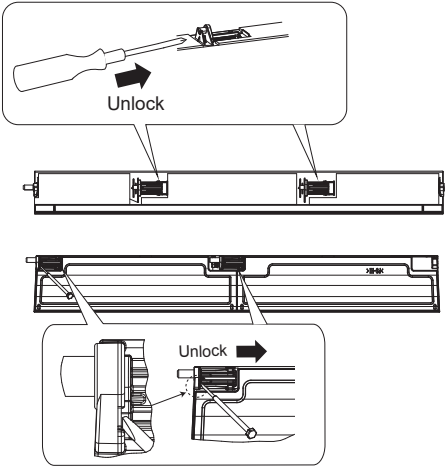
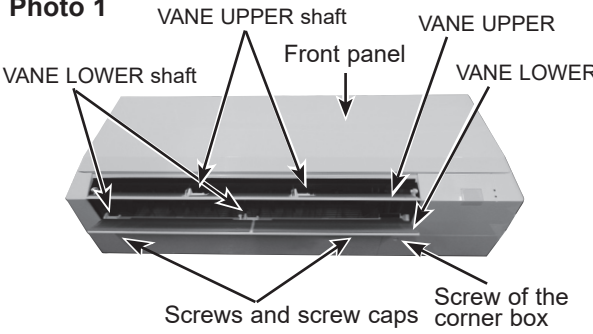
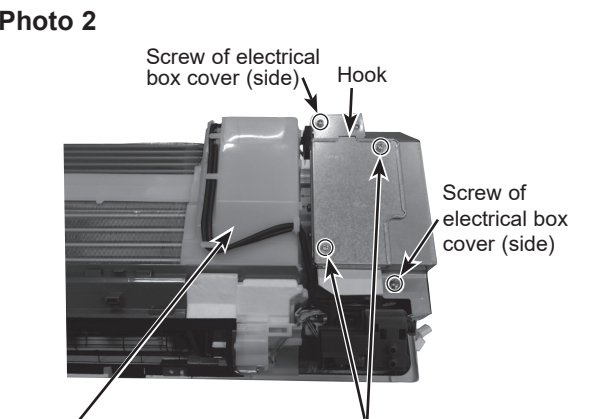
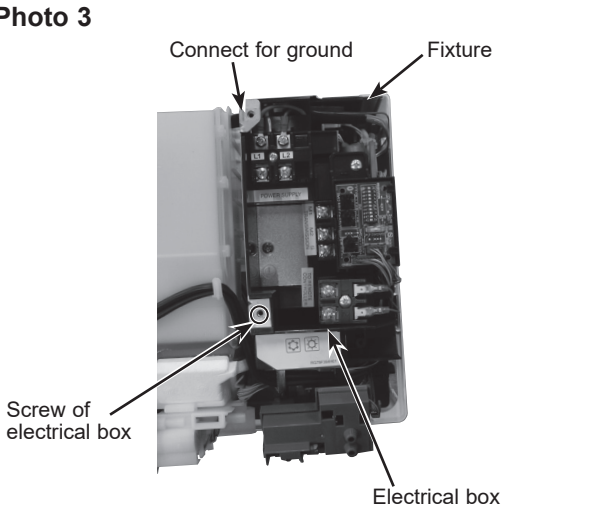
OPERATION PROCEDURE	PHOTOS/FIGURES
<p><b>1. REMOVING THE PANEL</b></p> <ol style="list-style-type: none"> <li>(1) Insert the driver to the hole at VANE LOWER shaft and slide the VANE LOWER shaft (2 places each). Push VANE UPPER shaft with the driver.</li> <li>(2) Pull the VANE LOWER and VANE UPPER from unit.</li> <li>(3) Remove 2 screw caps of the front panel. Remove 2 screws. (See Photo 1)</li> <li>(4) Hold the lower part of both ends of the front panel and pull it slightly toward you, and then remove the front panel by pushing it upward.</li> <li>(5) Remove the screw of the corner box. (See Photo 1) Remove the corner box.</li> </ol> <div data-bbox="245 719 767 1293" style="border: 1px solid black; padding: 5px; margin-top: 10px;"> <p>Unlock the stopper and remove the horizontal vanes using a tool like a screw driver. (See the illustration below.)</p>  </div>	<p><b>Photo 1</b></p>  <p><b>Photo 2</b></p> 
<p><b>2. REMOVING THE ELECTRICAL BOX</b></p> <ol style="list-style-type: none"> <li>(1) Remove the panel and corner box. (Refer to procedure 1)</li> <li>(2) Remove the front and side electrical box covers (2 screws each).</li> <li>(3) Remove the transmission wiring of TB5, the power supply wiring of TB2 and the wiring of MA-remote controller (TB15).</li> <li>(4) Disconnect the connectors on the indoor controller board.</li> <li>(5) Disconnect the connector for ground wire.</li> <li>(6) Remove the screw on lower side of the electrical box. (See Photo 3)</li> <li>(7) Push up the upper fixture catch to remove the box, then remove it from the box fixture.</li> </ol>	<p><b>Photo 3</b></p> 

## OPERATION PROCEDURE

### 3. REMOVING THE ADDRESS BOARD, THE INDOOR CONTROLLER BOARD, THE WIRELESS CONTROLLER BOARD, LED BOARD

- (1) Remove the panel and the corner box. (Refer to procedure 1)
- (2) Remove the front and side electrical box covers (2 screws each).
- (3) Disconnect the connectors of address board.
- (4) Disconnect the connectors on the indoor controller board. (See Photo 4)
- (5) Remove the switch board holder and open the cover.
- (6) Pull out the indoor controller board toward you then remove the indoor controller board and switch board. (See Photo 4)
- (7) Remove the holder of wireless remote controller board and LED board.
- (8) Disconnect the connector of wireless remote controller board and LED board.
- (9) Remove the wireless remote controller board and LED board from the holder.

**Photo 4**

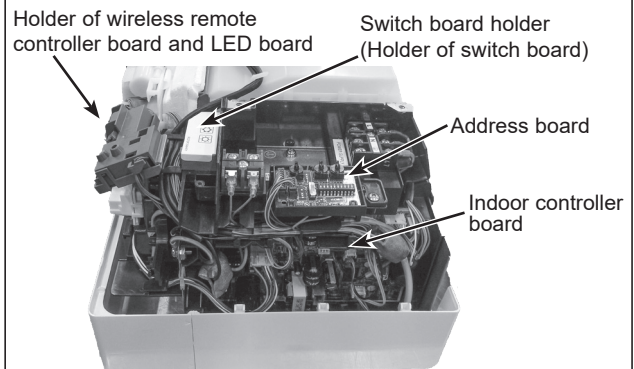

**Photo 5** (See the bottom)

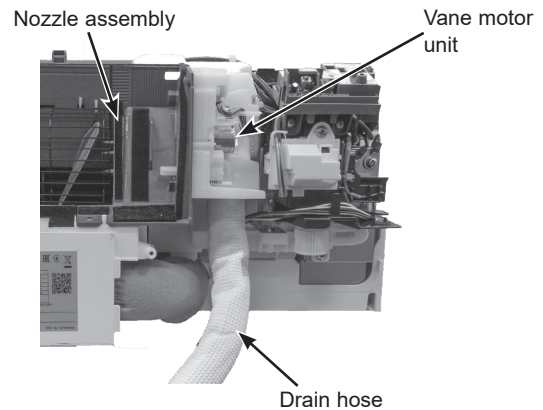

### 4. REMOVING THE NOZZLE ASSEMBLY (with VANE and VANE MOTOR) AND DRAIN HOSE

- (1) Remove the panel and corner box. (Refer to procedure 1)
- (2) Remove the electrical box covers. (Refer to procedure 2)
- (3) Disconnect the vane motor connector (CNV) on the indoor controller board.
- (4) Push fixture and pull out the drain hose from the nozzle assembly, and remove nozzle assembly. (See Photo 6)

**Photo 6**

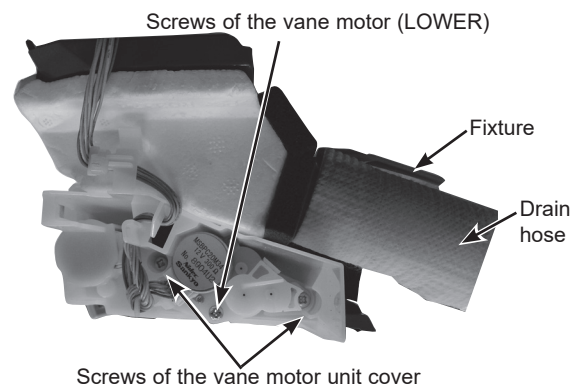

### 5. REMOVING THE VANE MOTOR

- (1) Remove the nozzle assembly. (Refer to procedure 4)
- (2) Remove 2 screws of the vane motor unit cover, and pull out the vane motor unit.
- (3) Remove screw of the vane motor (LOWER).
- (4) Remove the vane motor (LOWER) from the vane motor unit cover.
- (5) Disconnect the connector (white) from the vane motor. (LOWER)
- (6) Remove 2 screw of the vane motor (UPPER).
- (7) Remove the vane motor (UPPER) from the vane motor unit cover.
- (8) Disconnect the connector (blue) from the vane motor (UPPER).

**Photo 7**

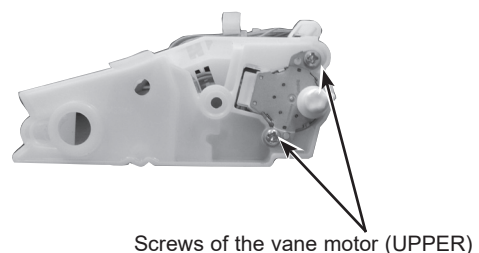

## OPERATION PROCEDURE

### 6. REMOVING THE INDOOR FAN MOTOR AND THE LINE FLOW FAN

- (1) Remove the panel and the corner box. (Refer to procedure 1)
- (2) Remove the electrical box (Refer to procedure 2) and the nozzle assembly (Refer to procedure 4).
- (3) Remove the water cover. (See Photo 2)
- (4) Loosen the screw fixing the line flow fan. (See Photo 9)
- (5) Remove 3 screws fixing the motor bed. (See Photo 8)
- (6) Remove the motor bed together with fan motor and motor band.
- (7) Release the 2 hooks of the motor band. Remove the motor band. Pull out the indoor fan motor.
- (8) Remove 2 screws fixing the left side of the heat exchanger. (See Photo 10)
- (9) Lift the heat exchanger, and pull out the line flow fan to the lower-left.

\* When attaching the line flow fan, screw the line flow fan so 4mm gap is provided between the right end of the line flow fan and the right wall of the air passage of the box. (Photo 9)

**Photo 10**

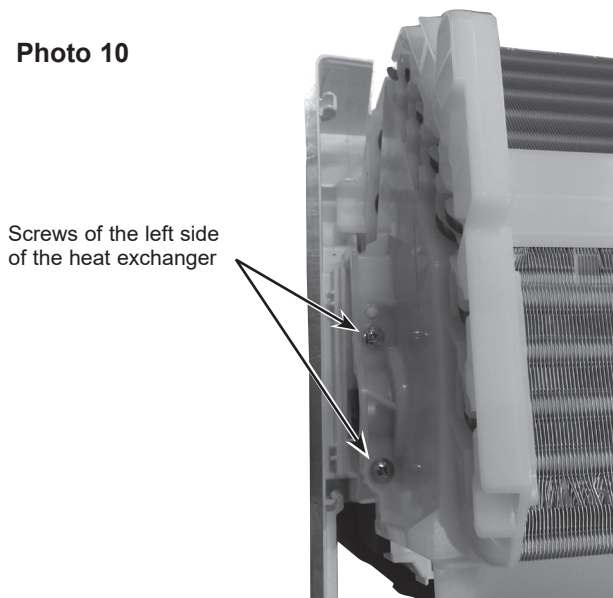

## PHOTOS/FIGURES

**Photo 8**

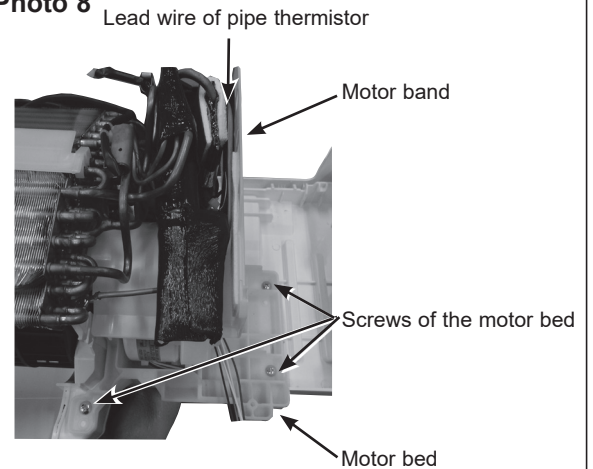

**Photo 9**

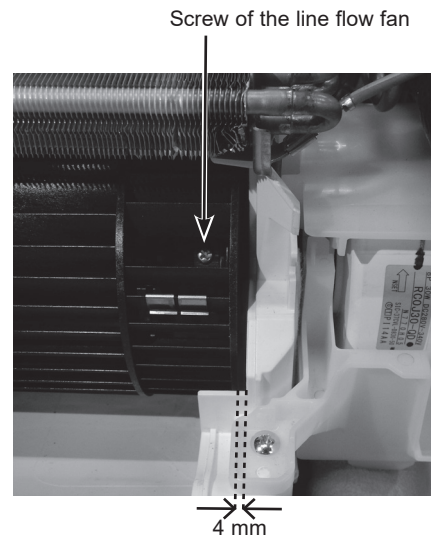

### 7. REMOVING THE LIQUID PIPE THERMISTOR AND GAS PIPE THERMISTOR

- (1) Remove the panel and the corner box. (Refer to procedure 1)
- (2) Remove the electrical box covers. (Refer to procedure 2)
- (3) Remove the water cover. (See Photo 2)
- (4) Remove the liquid pipe thermistor and gas pipe thermistors.
- (5) Disconnect the connector (CN44) on the indoor controller board. (TH22 and TH23/CN44)

**Photo 11**

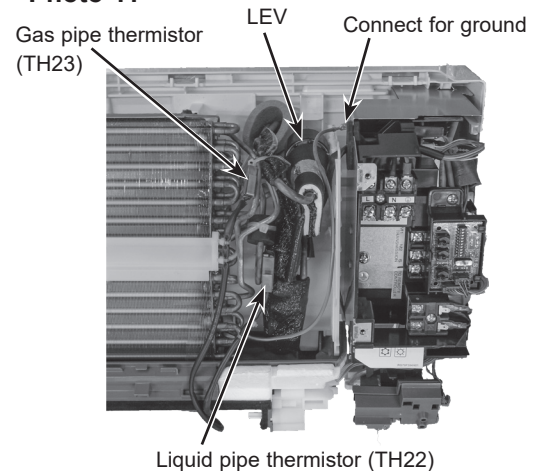

## OPERATION PROCEDURE

## PHOTOS/FIGURES

### 8. REMOVING THE HEAT EXCHANGER AND LEV

- (1) Remove the panel and the corner box (Refer to procedure 1).
- (2) Remove the electrical box (Refer to procedure 2) and the nozzle assembly (Refer to procedure 4).
- (3) Remove the water cover.
- (4) Remove the pipe thermistors. (Refer to procedure 7).
- (5) Disconnect the connector (CN60) on the indoor controller board.
- (6) Remove the motor bed together with fan motor and motor band (Refer to procedure 6).
- (7) Remove 2 screws fixing the left side of the heat exchanger. (See Photo 10)
- (8) Remove the heat exchanger with LEV.

Photo 12

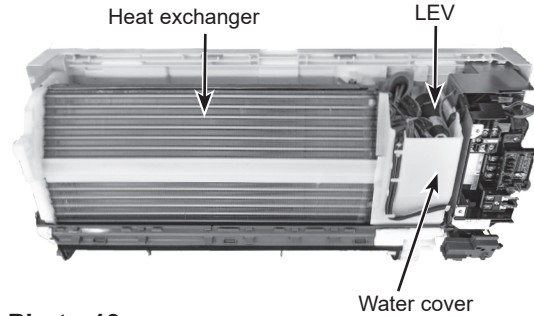
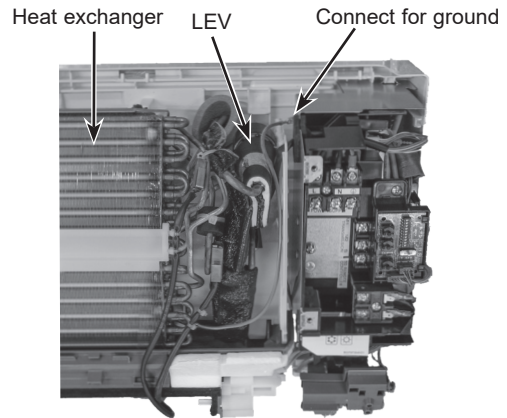

Photo 13



### 9. REMOVING THE ROOM TEMPERATURE THERMISTOR

- (1) Remove the panel and corner box. (Refer to procedure 1)
- (2) Remove the electrical box covers. (Refer to procedure 2)
- (3) Remove the room temperature thermistor.
- (4) Disconnect the connector (CN20) on the indoor controller board.

Photo 14

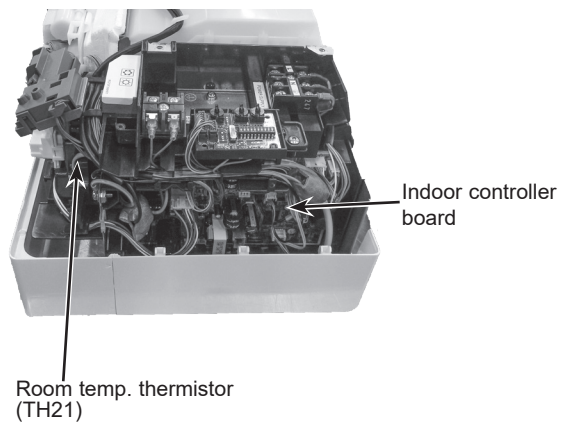

### 10. REMOVING THE LEV COIL

- (1) Remove the panel and corner box. (Refer to procedure 1)
- (2) Remove the electrical box covers. (Refer to procedure 2)
- (3) Remove the water cover. (See Photo 2)
- (4) Disconnect the LEV coil connector (CN60) on the indoor controller board.
- (5) Rotate the LEV coil and remove it. (See Photo 15)

Photo 15

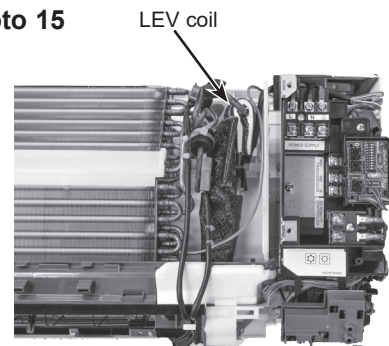

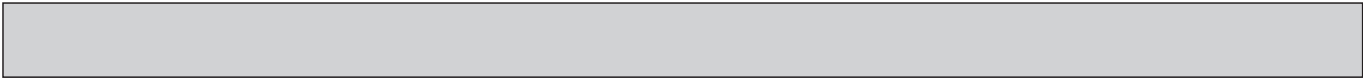

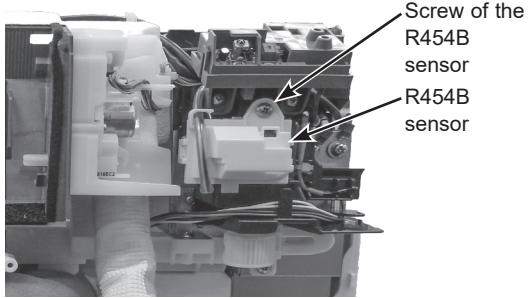
OPERATION PROCEDURE	PHOTOS/FIGURES
<p><b>11. REMOVING THE R454B SENSOR</b></p> <ol style="list-style-type: none"><li>(1) Remove the panel and corner box. (Refer to procedure 1)</li><li>(2) Remove the electrical box covers. (Refer to procedure 2)</li><li>(3) Disconnect the R454B sensor connector (CNSA) on the indoor controller board.</li><li>(4) Remove the screw fixing the R454B sensor. (See Photo 16)</li><li>(5) Remove the R454B sensor.</li></ol> <p>Note: This refrigerant sensor shall only be replaced with manufacturer approved sensor.</p>	<p><b>Photo 16</b> (see the bottom)</p> 

## 11-1. REMOTE CONTROLLER FUNCTIONS

&lt;PAR-42MAAUB&gt;

## Controller interface

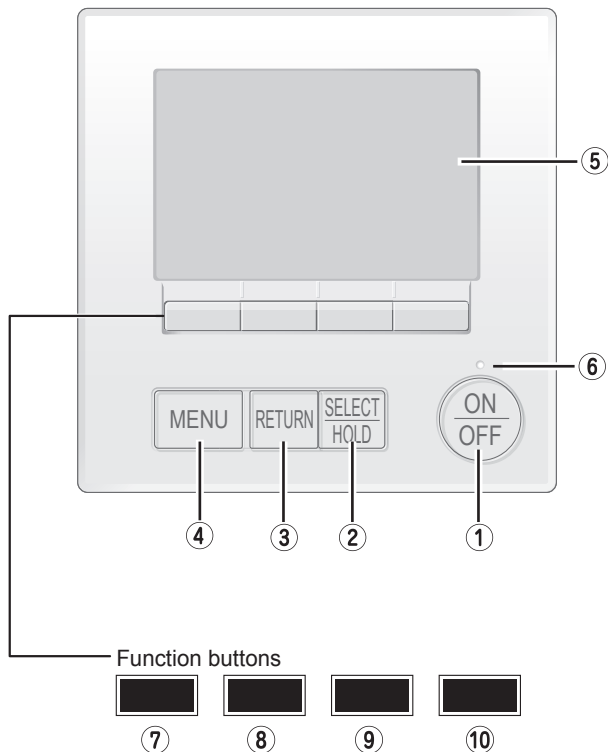

The functions of the function buttons change depending on the screen.

Refer to the button function guide that appears at the bottom of the LCD for the functions they serve on a given screen.

When the system is centrally controlled, the button function guide that corresponds to the locked button will not appear.

## Main display

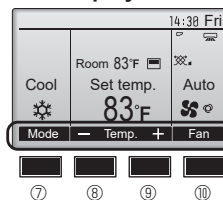

## Main menu

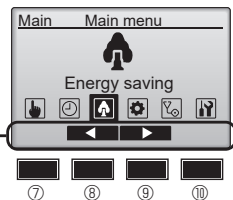

## Menu screen

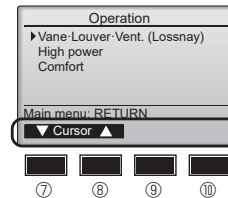

Function guide

**① [ON/OFF] button**

Press to turn ON/OFF the indoor unit.

**② [SELECT/HOLD] button**

Press to save the setting.  
When the Main menu is displayed, pressing this button will enable/disable the HOLD function.

**③ [RETURN] button**

Press to return to the previous screen.

**④ [MENU] button**

Press to bring up the Main menu.

**⑤ Backlit LCD**

Operation settings will appear.  
When the backlight is off, pressing any button turns the backlight on and it will stay lit for a certain period of time depending on the screen.

When the backlight is off, pressing any button turns the backlight on and does not perform its function. (except for the [ON/OFF] button)

**⑥ ON/OFF lamp**

This lamp lights up in green while the unit is in operation. It blinks while the remote controller is starting up or when there is an error.

**⑦ Function button [F1]**

Main display: Press to change the operation mode.  
Menu screen: The button function varies with the screen.

**⑧ Function button [F2]**

Main display: Press to decrease temperature.  
Main menu: Press to move the cursor left.  
Menu screen: The button function varies with the screen.

**⑨ Function button [F3]**

Main display: Press to increase temperature.  
Main menu: Press to move the cursor right.  
Menu screen: The button function varies with the screen.

**⑩ Function button [F4]**

Main display: Press to change the fan speed.  
Menu screen: The button function varies with the screen.

## Display

The main display can be displayed in two different modes: "Full" and "Basic". The initial setting is "Full". To switch to the "Basic" mode, change the setting on the Main display setting. (Refer to operation manual included with remote controller.)

### <Full mode>

All icons are displayed for explanation.

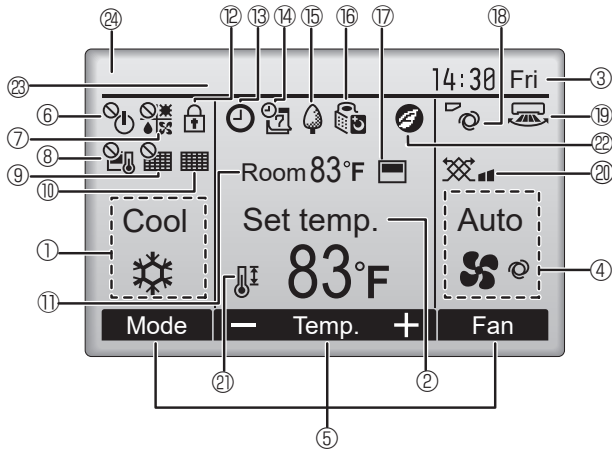

### <Basic mode>

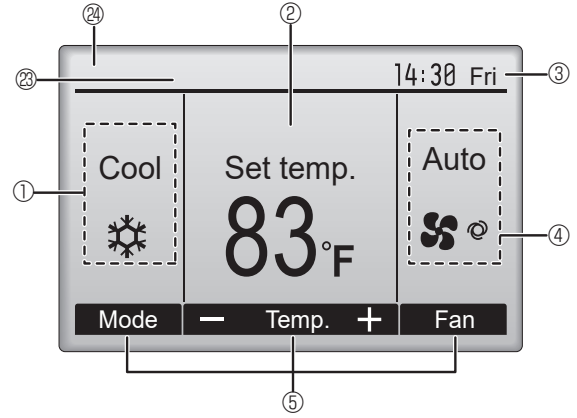

#### ① Operation mode

#### ② Preset temperature

#### ③ Clock

#### ④ Fan speed

#### ⑤ Button function guide

Functions of the corresponding buttons appear here.



Appears when the ON/OFF operation is centrally controlled.



Appears when the operation mode is centrally controlled.



Appears when the preset temperature is centrally controlled.



Appears when the filter reset function is centrally controlled.



Indicates when filter needs maintenance.

#### ⑪ Room temperature



Appears when the buttons are locked.



Appears when the On/Off timer or Auto-off timer function is enabled.

⌚ appears when the timer is disabled by the centralized control system.

⌚ appears when the HOLD function is enable.



Appears when the Weekly timer is enabled.



Appears while the units are operated in the energy saving mode. (Will not appear on some models of indoor units)



Appears while the outdoor units are operated in the silent mode.



Appears when the built-in thermistor on the remote controller is activated to monitor the room temperature (1).

⌚ appears when the thermistor on the indoor unit is activated to monitor the room temperature.



Indicates the vane setting.



Indicates the louver setting.



Indicates the ventilation setting.



Appears when the preset temperature range is restricted.



Appears when an energy saving operation is performed using a "3D i-see Sensor" function.

#### ②③ Centrally controlled

Appears for a certain period of time when a centrally-controlled item is operated.

#### ②④ Preliminary error display

A check code appears during the preliminary error.

Most settings (except ON/OFF, mode, fan speed, temperature) can be made from the Main menu.

## Menu structure

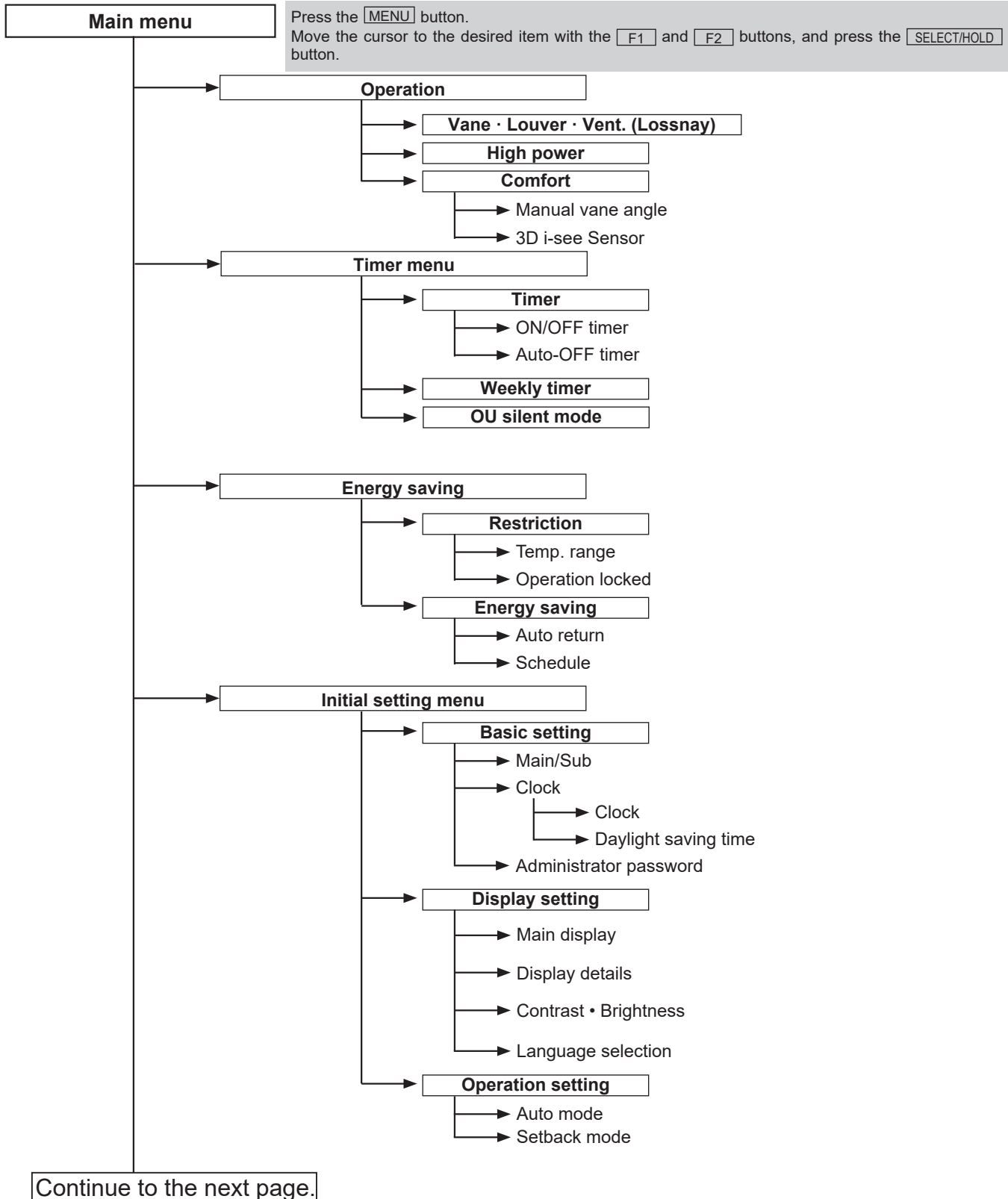

Not all functions are available on all models of indoor units.

Continue from the previous page.

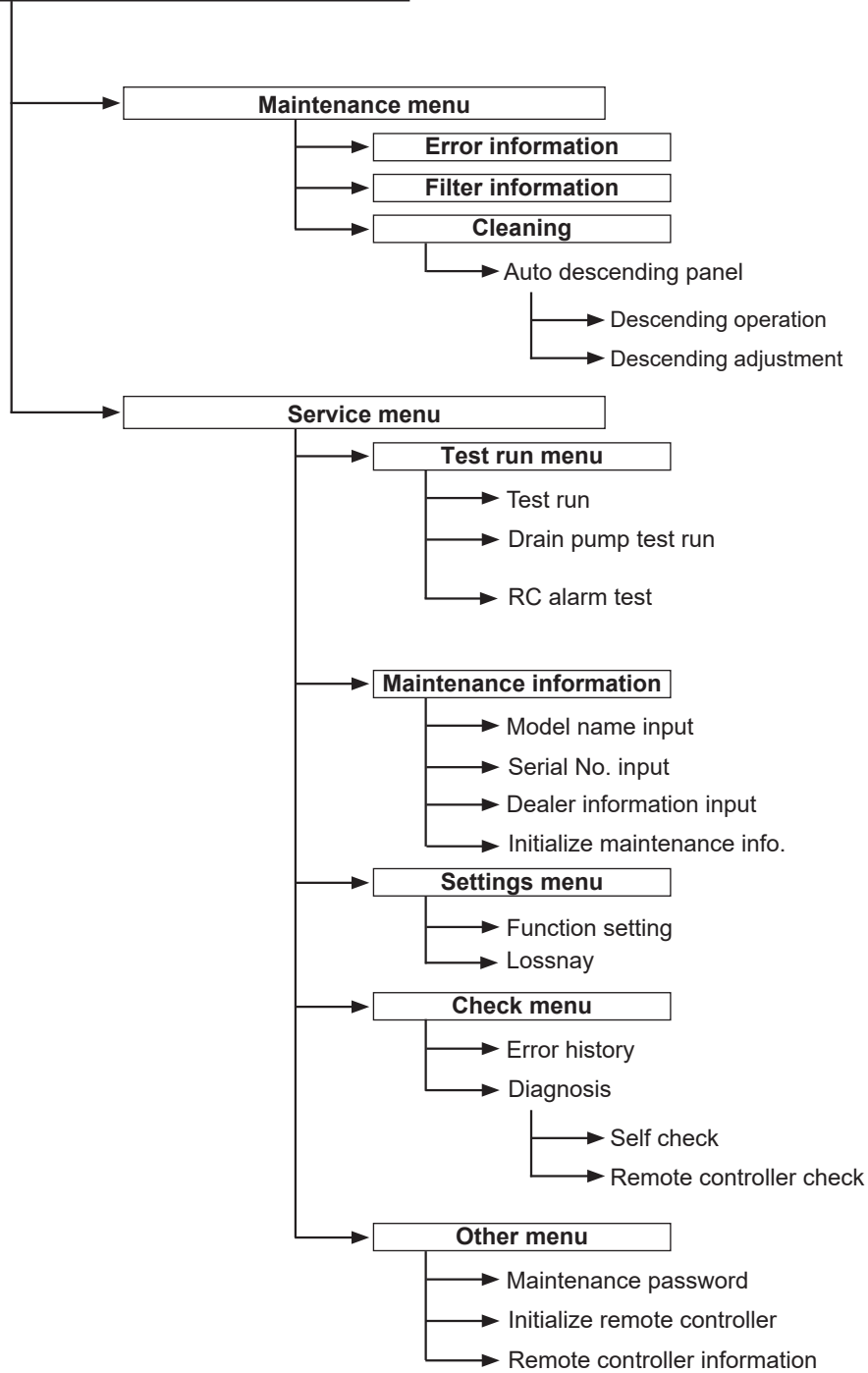

Not all functions are available on all models of indoor units.

## Main menu list

Main menu	Setting and display items		Setting details
Operation	Vane · Louver · Vent. (Lossnay)		<b>Use to set the vane angle.</b> • Select a desired vane setting from 5 different settings. <b>Use to turn ON/OFF the louver.</b> • Select a desired setting from "ON" and "OFF." <b>Use to set the amount of ventilation.</b> • Select a desired setting from "Off," "Low," and "High."
	High power		<b>Use to reach the comfortable room temperature quickly.</b> • Units can be operated in the High-power mode for up to 30 minutes.
	Comfort	Manual vane angle	<b>Use to fix each vane angle.</b>
		3D i-see Sensor	<b>Use to set the following functions for 3D i-see Sensor.</b> • Air distribution • Energy saving option • Seasonal airflow
Timer	Timer	ON/OFF timer *1	<b>Use to set the operation ON/OFF times.</b> • Time can be set in 5-minute increments.
		Auto-Off timer	<b>Use to set the Auto-Off time.</b> • Time can be set to a value from 30 to 240 in 10-minute increments.
	Weekly timer *1, *2		<b>Use to set the weekly operation ON/OFF times.</b> • Up to 8 operation patterns can be set for each day. (Not valid when the ON/OFF timer is enabled.)
	OU silent mode *1		<b>Use to set the time periods in which priority is given to quiet operation of outdoor units over temperature control. Set the Start/Stop times for each day of the week.</b> • Select the desired silent level from "Normal," "Middle," and "Quiet."
Energy saving	Restriction	Temp. range *2	<b>Use to restrict the preset temperature range.</b> • Different temperature ranges can be set for different operation modes.
		Operation lock	<b>Use to lock selected functions.</b> • The locked functions cannot be operated.
	Energy saving	Auto return *2	<b>Use to get the units to operate at the preset temperature after performing energy saving operation for a specified time period.</b> • Time can be set to a value from 30 and 120 in 10-minute increments. (This function will not be valid when the preset temperature ranges are restricted.)
		Schedule *1	<b>Set the start/stop times to operate the units in the energy saving mode for each day of the week, and set the energy saving rate.</b> • Up to 4 energy saving operation patterns can be set for each day. • Time can be set in 5-minute increments. • Energy saving rate can be set to a value from 0% or 50 to 90% in 10% increments.

\*1 Clock setting is required.

\*2 33.8°F (1°C) increments.

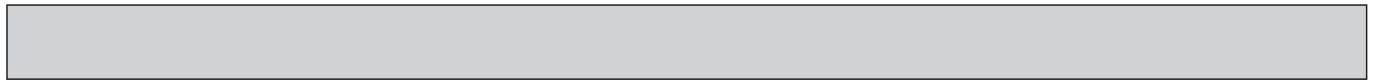

Main menu	Setting and display items		Setting details
Initial setting	Basic setting	Main/Sub	When connecting 2 remote controllers, one of them needs to be designated as a sub controller.
		Clock	Use to set the current time.
		Daylight saving time	Set the daylight saving time.
		Administrator password	The administrator password is required to make the settings for the following items. <ul style="list-style-type: none"> <li>• Timer setting</li> <li>• Energy saving setting</li> <li>• Weekly timer setting</li> <li>• Restriction setting</li> <li>• Outdoor unit silent mode setting</li> <li>• Night set back</li> </ul>
	Display setting	Main display	Use to switch between "Full" and "Basic" modes for the Main display. <ul style="list-style-type: none"> <li>• The initial setting is "Full."</li> </ul>
		Display details	Make the settings for the remote controller related items as necessary. <b>Clock:</b> The initial settings are "Yes" and "24h" format. <b>Temperature:</b> Set either Celsius (°C) or Fahrenheit (°F). <b>Room temp. :</b> Set Show or Hide. <b>Auto mode:</b> Set the Auto mode display or Only Auto display.
		Contrast • Brightness	Use to adjust screen contrast and brightness.
		Language selection	Use to select the desired language.
	Operation setting	Auto mode	Whether or not to use the Auto mode can be selected by using the button. This setting is valid only when indoor units with the Auto mode function are connected.
		Setback mode	Whether or not to use the Setback mode can be selected by using the button. This setting is valid only when indoor units with the Setback mode function are connected.
Maintenance	Error information		Use to check error information when an error occurs. <ul style="list-style-type: none"> <li>• Check code, error source, refrigerant address, unit model, manufacturing number, contact information (dealer's phone number) can be displayed.</li> </ul> (The unit model, manufacturing number, and contact information need to be registered in advance to be displayed.)
	Filter information		Use to check the filter status. <ul style="list-style-type: none"> <li>• The filter sign can be reset.</li> </ul>
	Cleaning	Auto descending panel	Use to lift and lower the auto descending panel (Optional parts).
Service	Test run		Select "Test run" from the Service menu to bring up the Test run menu. <ul style="list-style-type: none"> <li>• Test run</li> <li>• Drain pump test run</li> <li>• RC alarm test</li> </ul>
	Input maintenance		Select "Input maintenance Info." from the Service menu to bring up the Maintenance information screen. <b>The following settings can be made from the Maintenance Information screen.</b> <ul style="list-style-type: none"> <li>• Model name input</li> <li>• Serial No. input</li> <li>• Dealer information input</li> <li>• Initialize maintenance info.</li> </ul>
	Settings	Function setting	Make the settings for the indoor unit functions via the remote controller as necessary.
		LOSSNAY setting	This setting is required only when the operation of CITY MULTI units is interlocked with LOSSNAY units.
	Check	Error history	Display the error history and execute "delete error history".
		Diagnosis	<b>Self check:</b> Error history of each unit can be checked via the remote controller. <b>Remote controller check:</b> When the remote controller does not work properly, use the remote controller checking function to troubleshoot the problem.
	Other	Maintenance password	Use to change the maintenance password.
		Initialize remote controller	Use to initialize the remote controller to the factory shipment status.
Remote controller information		Use to display the remote controller model name, software version, and serial number.	

<PAR-SL101A-E>

**Controller interface**

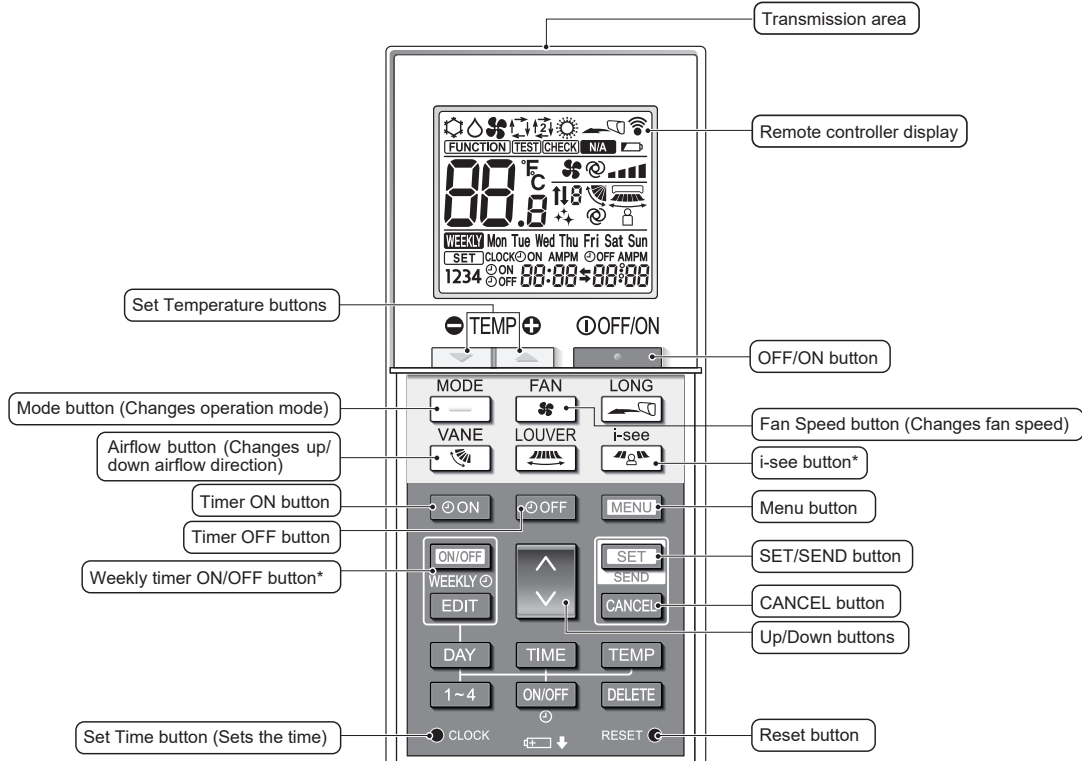

**Note:**

\* This button is enabled or disabled depending on the model of the indoor unit.

**Display**

**Operation mode**

- Cool (snowflake icon)
- Dry (water drop icon)
- Fan (fan icon)
- Auto (single set point) (circular arrow icon)
- Heat (sun icon)
- Auto (dual set point) (circular arrow with two dots icon)

**Temperature setting**  
The units of temperature can be changed. For details, refer to the Installation Manual.

**Vane setting**

Step 1 Step 2 Step 3 Step 4 Step 5 Swing Auto

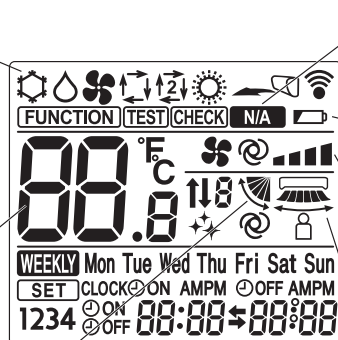

**Not available**  
Appears when a non-supported function is selected.

**Battery replacement indicator**  
Appears when the remaining battery power is low.

**Fan speed setting**

Auto

**3D i-see Sensor (Air distribution)**

Default Direct Indirect

When Direct or Indirect is selected, the vane setting is set to "Auto".

## 11-2. ERROR INFORMATION

**When an error occurs, the following screen will appear.  
Check the error status, stop the operation, and consult your dealer.**

1. Check code, error unit, refrigerant address, model name, and serial number will appear.  
The model name and serial number will appear only if the information has been registered.

Press the **[F1]** or **[F2]** button to go to the next page.

Error information		1/2
Error code	2502	
Error unit	IU	Unit#1
Time Occurred	02/01	4:48
Model name		
Serial No.		
Reset error: Reset button		
▼ Page ▲		Reset

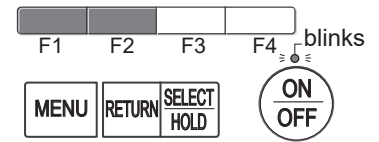

Contact information (dealer's phone number) will appear if the information has been registered.

Error information		2/2
Contact information		
Dealer		
Tel		
Reset error: Reset button		
▼ Page ▲		Reset

2. Press the **[F4]** button or the **[ON/OFF]** button to reset the error that is occurring.

**Errors cannot be reset while the ON/OFF operation is prohibited.**

Error information		1/2
Error code	2502	
Error unit	IU	Unit#1
Time Occurred	02/01	4:48
Model name		
Serial No.		
Reset error: Reset button		
▼ Page ▲		Reset

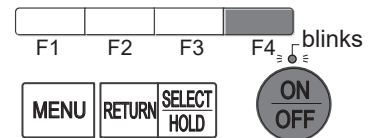

Select "OK" with the **[F4]** button.

Error reset	
Reset current error?	
Cancel OK	

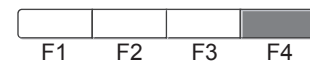

Error reset	
Error reset	
Main menu: MENU	

### Navigating through the screens

- To go back to the Service menu ..... **[MENU]** button

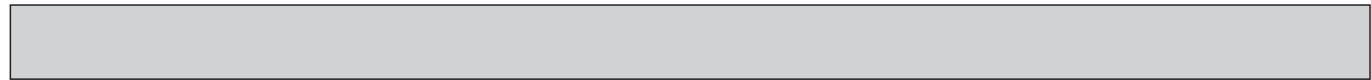

### • Checking the error information

While no errors are occurring, page 2/2 of the error information can be viewed by selecting "Error information" from the Maintenance menu. Errors cannot be reset from this screen.

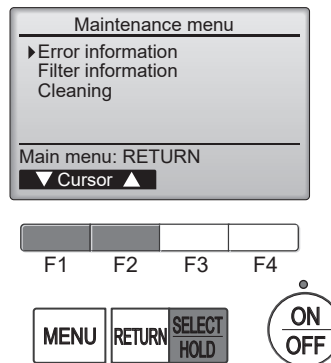

## 11-3. SERVICE MENU

### Maintenance password is required

1. Select "Service" from the Main menu, and press the [SELECT/HOLD] button.

\*At the main display, the menu button and select "Service" to make the maintenance setting.

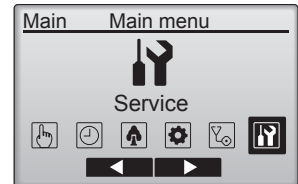

2. When the Service menu is selected, a window will appear asking for the password.

To enter the current maintenance password (4 numerical digits), move the cursor to the digit you want to change with the [F1] or [F2] button.



Set each number (0 through 9) with the [F3] or [F4] button.



Then, press the [SELECT/HOLD] button.

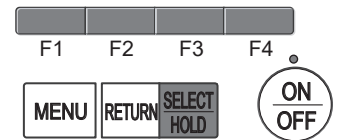
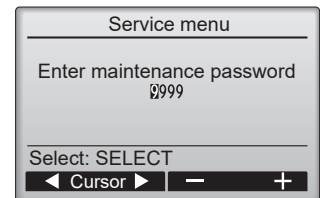

**Note:** The initial maintenance password is "9999". Change the default password as necessary to prevent unauthorized access. Have the password available for those who need it.

: If you forget your maintenance password, you can initialize the password to the default password "9999" by pressing and holding the [F1] button for 10 seconds on the maintenance password setting screen.

3. If the password matches, the Service menu will appear.

The type of menu that appears depends on the connected indoor units' type.

**Note:** Air conditioning units may need to be stopped to make only at "Settings". There may be some settings that cannot be made when the system is centrally controlled.



A screen will appear that indicates the setting has been saved.

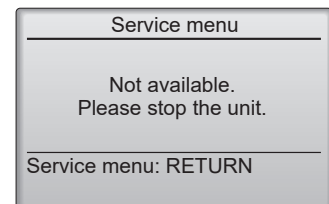
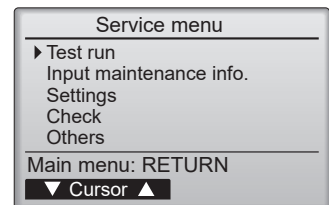

### Navigating through the screens

- To go back to the Service menu ..... [MENU] button
- To return to the previous screen..... [RETURN] button

## 11-4. TEST RUN

### 11-4-1. PAR-42MAAUB

1. Select "Service" from the Main menu, and press the [SELECT/HOLD] button.

Select "Test run" with the **F1** or **F2** button, and press the [SELECT/HOLD] button.

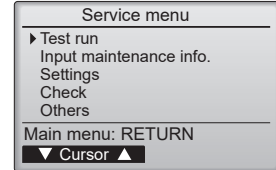

2. Select "Test run" with the **F1** or **F2** button, and press the [SELECT/HOLD] button.

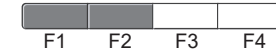
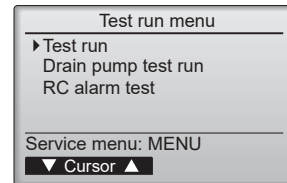

#### Test run operation

Press the **F1** button to go through the operation modes in the order of "Cool and Heat".

Cool mode: Check the cold air blows out.  
Heat mode: Check the heat blows out.

Check the operation of the outdoor unit's fan.

Press the [SELECT/HOLD] button and open the Vane setting screen.

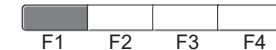
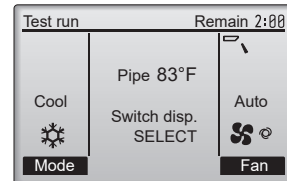

#### Auto vane check

Check the auto vane with the **F1** **F2** buttons.

Press the [RETURN] button to return to "Test run operation".







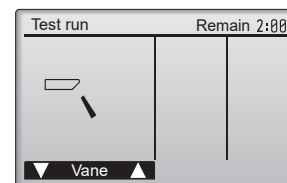



Press the [ON/OFF] button.

When the test run is completed, the "Test run menu" screen will appear. The test run will automatically stop after 2 hours.

\*The function is available only for the model with vanes.



## 11-4-2. PAR-SL101A-E

1. Press the  button ① to stop the air conditioner.
  - If the weekly timer is enabled (**WEEKLY** is on), press the  button ③ to disable it (**WEEKLY** is off).
2. Press the  button ② for 5 seconds.
  - **CHECK** comes on and the unit enters the service mode.
3. Press the  button ②.
  - **TEST** ④ comes on and the unit enters the test run mode.
4. Press the following buttons to start the test run.
  - : Switch the operation mode between cooling and heating and start the test run.
  - : Switch the fan speed and start the test run.
  - : Switch the airflow direction and start the test run.
  - : Switch the louver and start the test run.
  - : Start the test run.
5. Stop the test run.
  - Press the  button ① to stop the test run.
  - After 2 hours, the stop signal is transmitted.

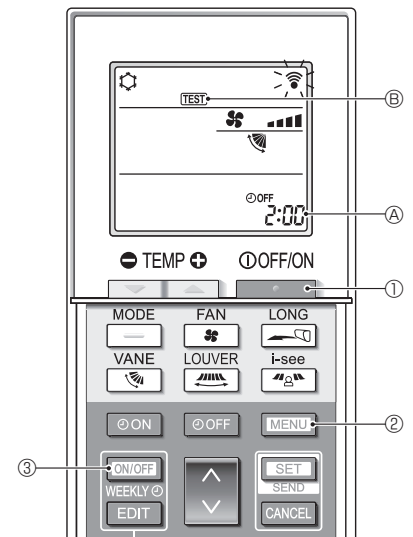

## 11-5. FUNCTION SETTING

### 11-5-1. PAR-42MAAUB

1. Select "Service" from the Main menu, and press the [SELECT/HOLD] button.

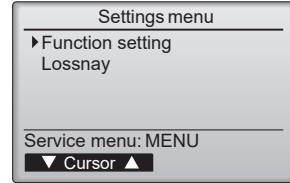

Select "Setting" from the Service menu, and press the [SELECT/HOLD] button.

Select "Function setting", and press the [SELECT/HOLD] button.

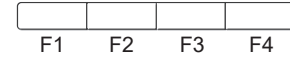

2. The Function setting screen will appear.

Press the [F1] or [F2] button to move the cursor to one of the following: M-NET address, function setting number, or setting value. Then, press the [F3] or [F4] button to change the settings to the desired settings.

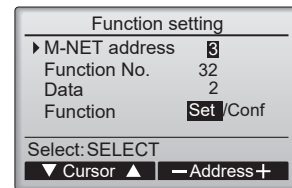

Once the settings have been completed, press the [SELECT/HOLD] button. A screen will appear indicating that the settings information is being sent. To check the current settings of a given unit, enter the setting for its M-NET address and function setting number, select Conf for the Function, and press the [SELECT/HOLD] button. A screen will appear indicating that the settings are being searched for. When the search is done, the current settings will appear.

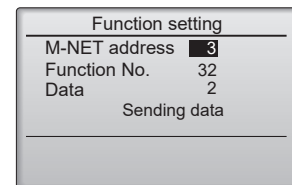

When the settings information has been sent, a screen will appear indicating its completion. To make additional settings, press the [RETURN] button to return to the screen shown in the above step. Set the function numbers for other indoor units by following the same steps.

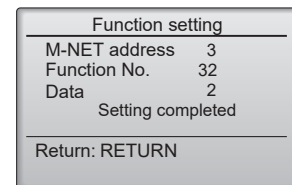

**Note:**

- Refer to the indoor unit Installation Manual for information about the factory settings of indoor units, function setting numbers, and setting values.
- Be sure to write down the settings for all functions if any of the initial settings has been changed after the completion of installation work.

## 11-6. ERROR HISTORY

1. Select "Service" from the Main menu, and press the [SELECT/HOLD] button.



Select "Check" with the [F1] or [F2] button, and press the [SELECT/HOLD] button.

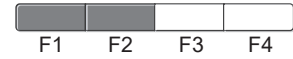
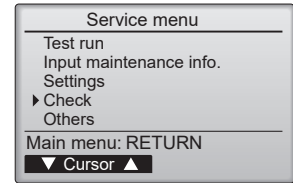

2. Select "Error history" with the [F1] or [F2] button, and press the [SELECT/HOLD] button.

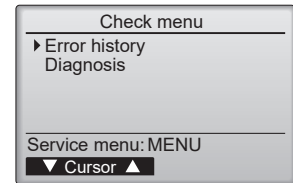

3. 16 error history records will appear.

4 records are shown per page, and the top record on the first page indicates the latest error record.

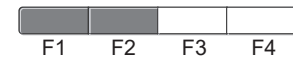
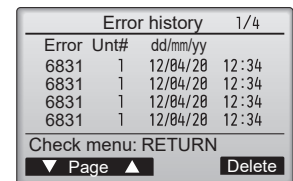

4. Deleting the error history

To delete the error history, press the [F4] button (Delete) on the screen that shows error history.

A confirmation screen will appear asking if you want to delete the error history.



Press the [F4] button (OK) to delete the history.



"Error history deleted" will appear on the screen.

Press the [RETURN] button to go back to the Check menu screen.

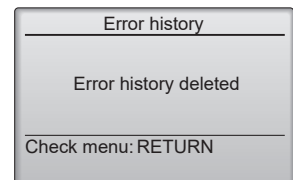
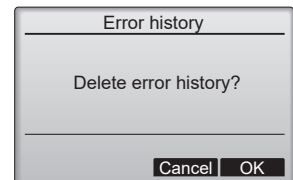

## 11-7. SELF-DIAGNOSIS

### 11-7-1. PAR-42MAAUB

1. Select "Service" from the Main menu, and press the [SELECT/HOLD] button.

Select "Check" from the Service menu, and press the [SELECT/HOLD] button.

Select "Diagnosis" from the Check menu, and press the [SELECT/HOLD] button.

Select "Self check" with the [F1] or [F2] button, and press the [SELECT/HOLD] button.

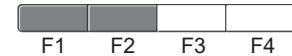
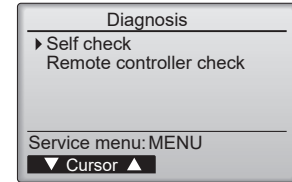

2. Select "Self check" from the Diagnosis menu, and press the [SELECT/HOLD] button to view the Self check screen.

With the [F1] or [F2] button, enter the M-NET address, and press the [SELECT/HOLD] button.

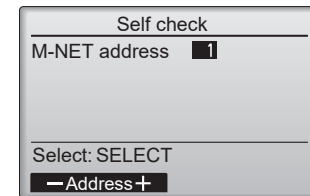

Check code, unit number, attribute, and indoor unit demand signal ON/OFF status at the contact will appear. "-" will appear if no error history is available.

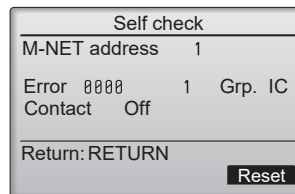

#### When there is no error history

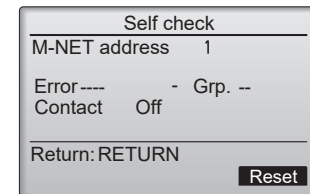

3. Resetting the error history

Press the [F4] button (Reset) on the screen that shows the error history. A confirmation screen will appear asking if you want to delete the error history.

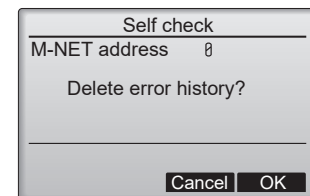

Press the [F4] button (OK) to delete the error history. If deletion fails, "Request rejected" will appear, and "Unit not exist" will appear if indoor units that correspond to the entered address are not found.

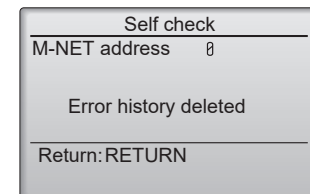

## 11-7-2. PAR-SL101A-E

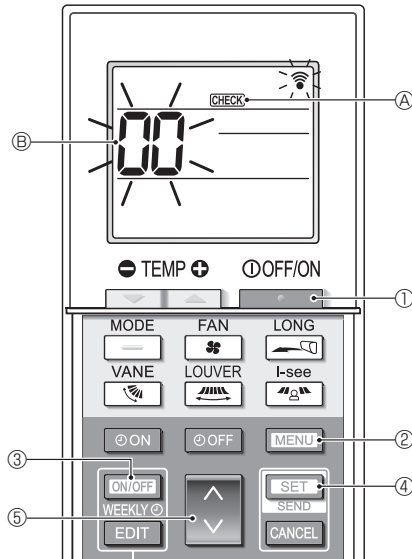

- Press the **OFF/ON** button ① to stop the air conditioner.
  - If the weekly timer is enabled (**WEEKLY** is on), press the **ON/OFF WEEKLY** button ③ to disable it (**WEEKLY** is off).
- Press the **MENU** button ② for 5 seconds.
  - CHECK** ① comes on and the unit enters the self-check mode.
- Press the **ON/OFF WEEKLY** button ⑤ to select the refrigerant address (M-NET address) ③ of the indoor unit for which you want to perform the self-check.
- Press the **SET** button ④.
  - If an error is detected, the check code is indicated by the number of beeps from the indoor unit and the number of blinks of the OPERATION INDICATOR lamp.
- Press the **OFF/ON** button ①.
  - CHECK** ① and the refrigerant address (M-NET address) ③ go off and the self-check is completed.

## 11-8. REFRIGERANT SENSOR UNNECESSARY SETTING

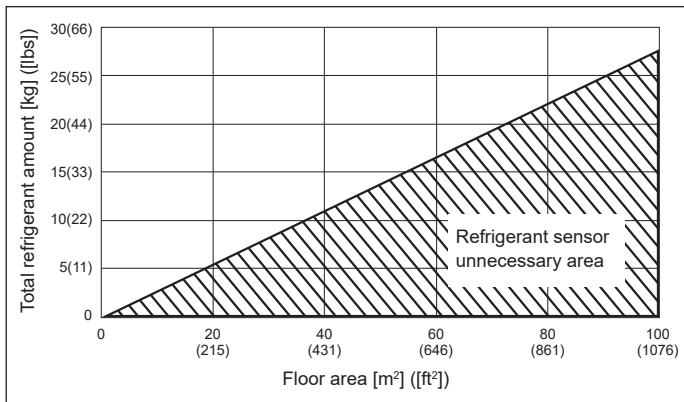

If  $M/A \leq 0.27$ , the refrigerant sensor can be disabled by disconnecting the CNSB connector on the control board.

M: Total refrigerant amount [kg] ([lbs])

A: Floor area [m<sup>2</sup>] ([ft<sup>2</sup>])

Caution: Do not disconnect the CNSB connector in an environment where  $M/A \geq 0.27$ .

If a refrigerant leak occurs with the refrigerant sensor disabled, the safety device will not be able to operate.

## 11-9. REMOTE CONTROLLER CHECK

If operations cannot be completed with the remote controller, diagnose the remote controller with this function.

1. Select "Service" from the Main menu, and press the [SELECT/HOLD] button.

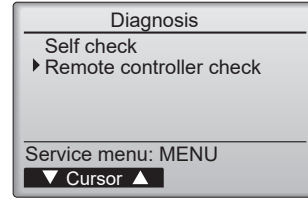

Select "Check" from the Service menu, and press the [SELECT/HOLD] button.

Select "Diagnosis" from the Check menu, and press the [SELECT/HOLD] button.

Select "Remote controller check" with the [F1] or [F2] button, and press the [SELECT/HOLD] button.

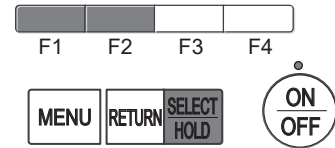

2. Select "Remote controller check" from the Diagnosis menu, and press the [SELECT/HOLD] button to start the remote controller check and see the check results.

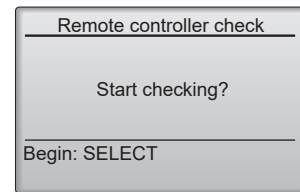

To cancel the remote controller check and exit the "Remote controller check" menu screen, press the [MENU] or the [RETURN] button.

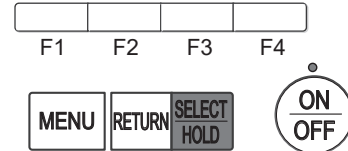

The remote controller will not reboot itself.

3.
  - OK: No problems are found with the remote controller. Check other parts for problems.
  - E3, 6832: There is noise on the transmission line, or the indoor unit or another remote controller is faulty. Check the transmission line and the other remote controllers.
  - NG (ALL0, ALL1): Send-receive circuit fault. The remote controller needs replacing.
  - ERC: The number of data errors is the discrepancy between the number of bits in the data transmitted from the remote controller and that of the data that was actually transmitted over the transmission line. If data errors are found, check the transmission line for external noise interference.

### Remote controller check results screen

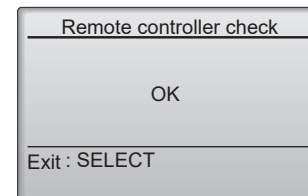

If the [SELECT/HOLD] button is pressed after the remote controller check results are displayed, remote controller check will end, and the remote controller will automatically reboot itself.

**Check the remote controller display and see if anything is displayed (including lines). Nothing will appear on the remote controller display if the correct voltage (8.5–12 VDC) is not supplied to the remote controller. If this is the case, check the remote controller wiring and indoor units.**

# CITY MULTI

## MITSUBISHI ELECTRIC CORPORATION

HEAD OFFICE: TOKYO BUILDING, 2-7-3, MARUNOUCHI, CHIYODA-KU TOKYO 100-8310, JAPAN