

OUTDOOR UNIT

Revision A:

• MXZ-3D24/4D30/5D36/5D42NL - U1
and MXZ-2D20/3D24/3D30NLHZ - U1
have been added.

OBH949 is void.

SERVICE MANUAL



**No. OBH949
REVISED EDITION-A**

Models

MXZ-2D20NL - U1 **MXZ-2D20NLHZ** - U1
MXZ-3D24NL - U1 **MXZ-3D24NLHZ** - U1
MXZ-4D30NL - U1 **MXZ-3D30NLHZ** - U1
MXZ-5D36NL - U1
MXZ-5D42NL - U1

Indoor unit service manual

MSZ-FX•NL Series (OBH945)
MSZ-EX•NL Series (OBH956)
MSZ-GX•NL Series (OBH950)
MFZ-KX•NL Series (OBH944)
MLZ-KX•NL Series (OBH943)
SLZ-AF•NL Series
SEZ-AD•NL Series
PEAD-AA•NL Series
SVZ-AP•NL Series
PAA-AA•NL Series
PAA-BA•NL Series

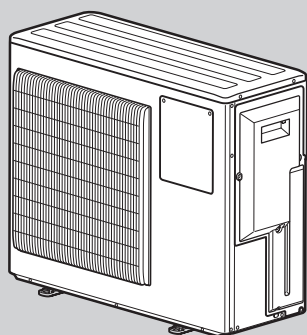

MXZ-2D20NL

CONTENTS

- INDOOR / OUTDOOR UNIT
COMPATIBILITY TABLE 3
- 1. TECHNICAL CHANGES 4
- 2. SAFETY PRECAUTION 5
- 3. PART NAMES AND FUNCTIONS 16
- 4. SPECIFICATION 17
- 5. NOISE CRITERIA CURVES 25
- 6. OUTLINES AND DIMENSIONS 27
- 7. WIRING DIAGRAM 33
- 8. REFRIGERANT SYSTEM DIAGRAM 39
- 9. DATA 52
- 10. ACTUATOR CONTROL 81
- 11. SERVICE FUNCTIONS 82
- 12. TROUBLESHOOTING 85
- 13. DISASSEMBLY INSTRUCTIONS 107

PARTS CATALOG (OBB949)

Use the specified refrigerant only

Never use any refrigerant other than that specified.

Doing so may cause a burst, an explosion, or fire when the unit is being used, serviced, or disposed of.

Correct refrigerant is specified in the manuals and on the spec labels provided with our products.

We will not be held responsible for mechanical failure, system malfunction, unit breakdown or accidents caused by failure to follow the instructions.

<Preparation before the repair service>

- Prepare the proper tools.
- Prepare the proper protectors.
- Provide adequate ventilation.
- After stopping the operation of the air conditioner, turn off the power-supply breaker and pull the power plug.
- Discharge the capacitor before the work involving the electric parts.

<Precautions during the repair service>

- Do not perform the work involving the electric parts with wet hands.
- Do not pour water into the electric parts.
- Do not touch the refrigerant.
- Do not touch the hot or cold areas in the refrigeration cycle.
- When the repair or the inspection of the circuit needs to be done without turning off the power, exercise great caution not to touch the live parts.
- Be careful not to expose the fusible plug to the braze torch flame or transfer heat to it.
The temperature of the fusible plug must not become 140°F (60°C) or higher while working.
Protect the fusible plug with a wet cloth when necessary.
(The fusible plug breaks at 158°F [70°C]).

WARNING

- **When the refrigerant circuit has a leak, do not execute pump down with the compressor.**
- **When pumping down the refrigerant, stop the compressor before disconnecting the refrigerant pipes.**
If the refrigerant pipes are disconnected while the compressor is running and the stop valve is open, air could be drawn in and the pressure in the refrigeration cycle could become abnormally high.
The compressor may burst and cause injury if any foreign substance, such as air, enters the pipes.
- **When opening or closing the valve below freezing temperatures, refrigerant may spurt out from the gap between the valve stem and the valve body, resulting in injuries.**

Revision A:

- MXZ-3D24/4D30/5D36/5D42NL-[U1] and MXZ-2D20/3D24/3D30NLHZ-[U1] have been added.

INDOOR / OUTDOOR UNIT COMPATIBILITY TABLE

<MXZ-2D20NL>

Connectable indoor unit lineups (Heat pump inverter type)							
Model type	Model name	Capacity class [Btu/h]					
		06	09	12	15	18	24
Wall-mounted	MSZ-FX**NL	●	●	●	●		
	MSZ-EX**NL		●	●	●		
	MSZ-GX**NL	●	●	●	●		
Floor standing	MFZ-KX**NL		●	●	●		
1way cassette	MLZ-KX**NL	●	●	●			
4way cassette	SLZ-AF**NL		●	●			
Horizontal ducted	SEZ-AD**NL		●	●	●		
	PEAD-AA**NL		●	●			
Multi position	SVZ-AP**NL			●			
	PAA-AA**NL						
	PAA-BA**NL						

<MXZ-2D20NLHZ>

Connectable indoor unit lineups (Heat pump inverter type)							
Model type	Model name	Capacity class [Btu/h]					
		06	09	12	15	18	24
Wall-mounted	MSZ-FX**NL	●	●	●	●		
	MSZ-EX**NL		●	●	●		
	MSZ-GX**NL	●	●	●	●		
Floor standing	MFZ-KX**NL		●	●	●		
1way cassette	MLZ-KX**NL	●	●	●			
4way cassette	SLZ-AF**NL		●	●			
Horizontal ducted	SEZ-AD**NL		●	●	●		
	PEAD-AA**NL		●	●			
Multi position	SVZ-AP**NL			●			
	PAA-AA**NL						
	PAA-BA**NL						

<MXZ-3D24NL>

Connectable indoor unit lineups (Heat pump inverter type)							
Model type	Model name	Capacity class [Btu/h]					
		06	09	12	15	18	24
Wall-mounted	MSZ-FX**NL	●	●	●	●	●	
	MSZ-EX**NL		●	●	●	●	
	MSZ-GX**NL	●	●	●	●	●	
Floor standing	MFZ-KX**NL		●	●	●	●	
1way cassette	MLZ-KX**NL	●	●	●		●	
4way cassette	SLZ-AF**NL		●	●	●	●	
Horizontal ducted	SEZ-AD**NL		●	●	●	●	
	PEAD-AA**NL		●	●	●	●	
Multi position	SVZ-AP**NL			●		●	
	PAA-AA**NL					●	
	PAA-BA**NL					●	

<MXZ-3D24NLHZ>

Connectable indoor unit lineups (Heat pump inverter type)							
Model type	Model name	Capacity class [Btu/h]					
		06	09	12	15	18	24
Wall-mounted	MSZ-FX**NL	●	●	●	●	●	
	MSZ-EX**NL		●	●	●	●	
	MSZ-GX**NL	●	●	●	●	●	
Floor standing	MFZ-KX**NL		●	●	●	●	
1way cassette	MLZ-KX**NL	●	●	●		●	
4way cassette	SLZ-AF**NL		●	●	●	●	
Horizontal ducted	SEZ-AD**NL		●	●	●	●	
	PEAD-AA**NL		●	●	●	●	
Multi position	SVZ-AP**NL			●		●	
	PAA-AA**NL					●	
	PAA-BA**NL					●	

<MXZ-4D30NL>

Connectable indoor unit lineups (Heat pump inverter type)							
Model type	Model name	Capacity class [Btu/h]					
		06	09	12	15	18	24
Wall-mounted	MSZ-FX**NL	●	●	●	●	●	
	MSZ-EX**NL		●	●	●	●	
	MSZ-GX**NL	●	●	●	●	●	●
Floor standing	MFZ-KX**NL		●	●	●	●	
1way cassette	MLZ-KX**NL	●	●	●		●	
4way cassette	SLZ-AF**NL		●	●	●	●	
Horizontal ducted	SEZ-AD**NL		●	●	●	●	
	PEAD-AA**NL		●	●	●	●	●
Multi position	SVZ-AP**NL			●		●	●
	PAA-AA**NL					●	●
	PAA-BA**NL					●	●

<MXZ-3D30NLHZ>

Connectable indoor unit lineups (Heat pump inverter type)							
Model type	Model name	Capacity class [Btu/h]					
		06	09	12	15	18	24
Wall-mounted	MSZ-FX**NL	●	●	●	●	●	
	MSZ-EX**NL		●	●	●	●	
	MSZ-GX**NL	●	●	●	●	●	●
Floor standing	MFZ-KX**NL		●	●	●	●	
1way cassette	MLZ-KX**NL	●	●	●		●	
4way cassette	SLZ-AF**NL		●	●	●	●	
Horizontal ducted	SEZ-AD**NL		●	●	●	●	
	PEAD-AA**NL		●	●	●	●	●
Multi position	SVZ-AP**NL			●		●	●
	PAA-AA**NL					●	●
	PAA-BA**NL					●	●

<MXZ-5D36/42NL>

Connectable indoor unit lineups (Heat pump inverter type)							
Model type	Model name	Capacity class [Btu/h]					
		06	09	12	15	18	24
Wall-mounted	MSZ-FX**NL	●	●	●	●	●	
	MSZ-EX**NL		●	●	●	●	
	MSZ-GX**NL	●	●	●	●	●	●
Floor standing	MFZ-KX**NL		●	●	●	●	
1way cassette	MLZ-KX**NL	●	●	●		●	
4way cassette	SLZ-AF**NL		●	●	●	●	
Horizontal ducted	SEZ-AD**NL		●	●	●	●	
	PEAD-AA**NL		●	●	●	●	●
Multi position	SVZ-AP**NL			●		●	●
	PAA-AA**NL					●	●
	PAA-BA**NL					●	●

- Up to two SVZ/PAA can be connected, at that time the total number of connections is two.
When one SVZ/PAA is connected, there's no limitation of the total number of connection.
- PEAD series can be connected up to 2 units.(Connection of three or more units is prohibited.)
- Do not use SVZ/PAA and PEAD together.
- SVZ can be blown down only when using an optional kit.
- MFZ series can be connected up to 2 units.(Connection of three or more units is prohibited.)

MXZ-2D20NL - U1

1. New model

MXZ-3D24NL - U1

MXZ-4D30NL - U1

MXZ-5D36NL - U1

MXZ-5D42NL - U1

MXZ-2D20NLHZ - U1

MXZ-3D24NLHZ - U1

MXZ-3D30NLHZ - U1

1. New model

MEANINGS OF SYMBOLS DISPLAYED ON INDOOR UNIT AND/OR OUTDOOR UNIT

	Refrigerant Safety Group A2L	WARNING (Risk of fire)	This unit uses a flammable refrigerant. If refrigerant leaks and comes in contact with fire or heating part, it will create harmful gas and there is risk of fire.
	Read the OPERATING INSTRUCTIONS carefully before operation.		
	Service personnel are required to carefully read the OPERATING INSTRUCTIONS and INSTALLATION MANUAL before operation.		
	Further information is available in the OPERATING INSTRUCTIONS, INSTALLATION MANUAL, and the like.		

2-1. ALWAYS OBSERVE FOR SAFETY

Before obtaining access to terminal, all supply circuit must be disconnected.

Preparation before the repair service

- Prepare the proper tools.
- Prepare the proper protectors.
- Provide adequate ventilation.
- After stopping the operation of the air conditioner, turn off the power-supply breaker.
- Discharge the condenser before the work involving the electric parts.

Precautions during the repair service

- Do not perform the work involving the electric parts with wet hands.
- Do not pour water into electric parts.
- Do not touch the refrigerant.
- Do not touch the hot or cold areas in the refrigerating cycle.
- When the repair or the inspection of the circuit needs to be done without turning off the power, exercise great caution not to touch the live parts.
- When opening or closing the valve below freezing temperatures, refrigerant may spurt out from the gap between the valve stem and the valve body, resulting in injuries.

2-2. CAUTIONS RELATED TO R454B REFRIGERANT

Cautions for units utilizing refrigerant R454B

Make sure that the inside and outside of refrigerant piping is clean and it has no contaminants such as sulfur, oxides, dirt, shaving particles, etc., which are hazard to refrigerant cycle. In addition, use pipes with specified thickness.

Contamination inside refrigerant piping can cause deterioration of refrigerant oil, etc.

Store the piping indoors, and keep both ends of the piping sealed until just before brazing. (Leave elbow joints, etc. in their packaging.)

If dirt, dust or moisture enters into refrigerant cycle, that can cause deterioration of refrigerant oil or malfunction of compressor.

The refrigerant oil applied to flare and flange connections must be ester oil, ether oil or alkylbenzene oil in a small amount.

If large amount of mineral oil enters, that can cause deterioration of refrigerant oil, etc.

Charge refrigerant from liquid phase of gas cylinder.

If the refrigerant is charged from gas phase, composition change may occur in refrigerant and the efficiency will be lowered.

Do not use refrigerant other than R454B.

If other refrigerant (R22, etc.) is used, chlorine in refrigerant can cause deterioration of refrigerant oil, etc.

Use a vacuum pump with a reverse flow check valve.

Vacuum pump oil may flow back into refrigerant cycle and that can cause deterioration of refrigerant oil, etc.

Use the following tools specifically designed for use with R454B refrigerant.

The following tools are necessary to use R454B refrigerant.

Tools for R454B	
Gauge manifold	Flare tool
Charge hose	Size adjustment gauge
Gas leak detector	Vacuum pump adaptor
Torque wrench	Electronic refrigerant charging scale

Handle tools with care.

If dirt, dust or moisture enters into refrigerant cycle, that can cause deterioration of refrigerant oil or malfunction of compressor.

Use the specified refrigerant only.

Never use any refrigerant other than that specified.

Doing so may cause a burst, an explosion, or fire when the unit is being used, serviced, or disposed of. Correct refrigerant is specified in the manuals and on the spec labels provided with our products. We will not be held responsible for mechanical failure, system malfunction, unit breakdown or accidents caused by failure to follow the instructions.

Do not use a charging cylinder.

If a charging cylinder is used, the composition of refrigerant will change and the efficiency will be lowered.

Ventilate the room if refrigerant leaks during operation. If refrigerant comes into contact with a flame, poisonous gases will be released.

[1] Warning for service

- (1) Do not alter the unit.
- (2) For installation and relocation work, follow the instructions in the Installation Manual and use tools and pipe components specifically made for use with refrigerant specified in the outdoor unit installation manual.
- (3) Ask a dealer or an authorized technician to install, relocate and repair the unit.
For appliances not accessible to the general public.
- (4) Refrigerant pipe connections shall be accessible for maintenance purposes.
- (5) If the air conditioner is installed in a small room or closed room, measures must be taken to prevent the refrigerant concentration in the room from exceeding the safety limit in the event of refrigerant leakage. Should the refrigerant leak and cause the concentration limit to be exceeded, hazards due to lack of oxygen in the room may result.
- (6) Keep gas-burning appliances, electric heaters, and other fire sources (ignition sources) away from the location where installation, repair, and other air conditioner work will be performed.
If refrigerant comes into contact with a flame, poisonous gases will be released.
- (7) When installing, relocating, or servicing the air conditioner, use only the specified refrigerant (R454B) to charge the refrigerant lines.
Do not mix it with any other refrigerant and do not allow air to remain in the lines.
If air is mixed with the refrigerant, then it can be the cause of abnormal high pressure in the refrigerant line, and may result in an explosion and other hazards.
- (8) After installation has been completed, check for refrigerant leaks. If refrigerant leaks into the room and comes into contact with the flame of a heater or portable cooking range, poisonous gases will be released.
- (9) Do not use low temperature solder alloy in case of brazing the refrigerant pipes.
- (10) When performing brazing work, be sure to ventilate the room sufficiently. Make sure that there are no hazardous or flammable materials nearby.
When performing the work in a closed room, small room, or similar location, make sure that there are no refrigerant leaks before performing the work.
If refrigerant leaks and accumulates, it may ignite or poisonous gases may be released.
- (11) Do not install the unit in places where refrigerant may build-up or places with poor ventilation such as a semi-basement or a sunken place in outdoor: Refrigerant is heavier than air, and inclined to fall away from the leak source.
- (12) Do not use means to accelerate the defrosting process or to clean, other than those recommended by the manufacturer.
- (13) The appliance shall be stored in a room without continuously operating ignition sources (for example: open flames, an operating gas appliance or an operating electric heater).
- (14) Do not pierce or burn.
- (15) Be aware that refrigerants may not contain an odor.
- (16) Pipe-work shall be protected from physical damage.
- (17) The installation of pipe-work shall be kept to a minimum.
- (18) Compliance with national gas regulations shall be observed.
- (19) Keep any required ventilation openings clear of obstruction.
- (20) Servicing shall be performed only as recommended by the manufacturer.
- (21) The appliance shall be stored in a well-ventilated area where the room size corresponds to the necessary room size to meet safety requirements.
- (22) Maintenance, service and repair operations shall be performed by authorized technician with required qualification.
- (23) Be sure to have appropriate ventilation in order to prevent ignition. Furthermore, be sure to carry out fire prevention measures that there are no dangerous or flammable objects in the surrounding area.
- (24) Pipe-work including piping material, pipe routing, and installation shall include protection from physical damage in operation and service, and be in compliance with national and local codes and standards, such as ASHRAE 15, ASHRAE 15.2, IAPMO Uniform Mechanical Code, ICC International Mechanical Code, or CSA 852.
- (25) All field joints shall be accessible for inspection prior to being covered or enclosed.
- (26) Do not use low temperature solder alloy in the case of brazing the refrigerant pipes.
- (27) Servicing shall be performed only as recommended by the manufacturer.
- (28) The appliance shall be stored in a well-ventilated area where the room size corresponds to the room area as specified for operation.

[2] Cautions for service

- (1) **Perform service after recovering the refrigerant left in unit completely.**
- (2) **Do not release refrigerant in the air.**
- (3) **If moisture or foreign matter might have entered the refrigerant piping during service, ensure to remove them.**
- (4) **After completing service, charge the system with specified amount of refrigerant.**

[3] Additional refrigerant charge

When charging directly from cylinder

- (1) Check that cylinder for R454B on the market is a siphon type.
- (2) Charging should be performed with the cylinder of siphon stood vertically. (Refrigerant is charged from liquid phase.)

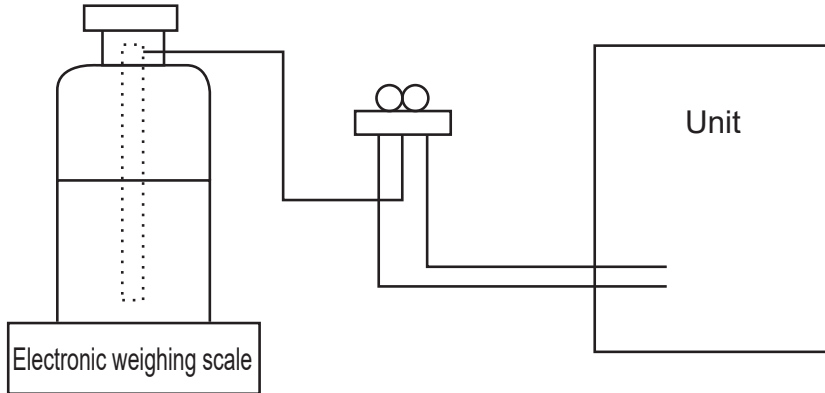

[4] Cautions for unit using R454B refrigerant

Basic work procedures are the same as those for conventional units using refrigerant R410A. However, pay careful attention to the following points.

- (1) Information on servicing
 - (1-1) Checks on the Area

Prior to beginning work on systems containing flammable refrigerants, safety checks are necessary to ensure that the risk of ignition is minimized.

For repair to the refrigerating systems, (1-3) to (1-7) shall be completed prior to conducting work on the systems.
 - (1-2) Work Procedure

Work shall be undertaken under a controlled procedure so as to minimize the risk of a flammable gas or vapor being present while the work is being performed.
 - (1-3) General Work Area

All maintenance staff and others working in the local area shall be instructed on the nature of work being carried out. Work in confined spaces shall be avoided. The area around the workspace shall be sectioned off. Ensure that the conditions within the area have been made safe by control of flammable material.
 - (1-4) Checking for Presence of Refrigerant

The area shall be checked with an appropriate refrigerant detector prior to and during work, to ensure the technician is aware of potentially toxic or flammable atmospheres. Ensure that the leak detection equipment being used is suitable for use with all applicable refrigerants, i.e. non-sparking, adequately sealed or intrinsically safe.
 - (1-5) Presence of Fire Extinguisher

If any hot work is to be conducted on the refrigeration equipment or any associated parts, appropriate fire extinguishing equipment shall be available at hand.

Have a dry powder or CO₂ fire extinguisher adjacent to the charging area.
 - (1-6) No Ignition Sources

No person carrying out work in relation to a refrigeration system which involves exposing any pipe work shall use any sources of ignition in such a manner that it may lead to the risk of fire or explosion. All possible ignition sources, including cigarette smoking, should be kept sufficiently far away from the site of installation, repairing, removing and disposal, during which refrigerant can possibly be released to the surrounding space. Prior to work taking place, the area around the equipment is to be surveyed to make sure that there are no flammable hazards or ignition risks. "No Smoking" signs shall be displayed.
 - (1-7) Ventilated Area

Ensure that the area is in the open or that it is adequately ventilated before breaking into the system or conducting any hot work. A degree of ventilation shall continue during the period that the work is carried out. The ventilation should safely disperse any released refrigerant and preferably expel it externally into the atmosphere.
 - (1-8) Checks on the Refrigeration Equipment

Where electrical components are being changed, they shall be fit for the purpose and to the correct specification. At all times the manufacturer's maintenance and service guidelines shall be followed. If in doubt, consult the manufacturer's technical department for assistance.

The following checks shall be applied to installations using flammable refrigerants:

- The charge size is in accordance with the room size within which the refrigerant containing parts are installed.
- The ventilation machinery and outlets are operating adequately and are not obstructed.
- Marking to the equipment continues to be visible and legible. Markings and signs that are illegible shall be corrected.
- Refrigeration pipe or components are installed in a position where they are unlikely to be exposed to any substance which may corrode refrigerant containing components, unless the components are constructed of materials which are inherently resistant to being corroded or are suitably protected against being corroded.

(1-9) Checks on Electrical Devices

Repair and maintenance to electrical components shall include initial safety checks and component inspection procedures. If a fault exists that could compromise safety, then no electrical supply shall be connected to the circuit until it is satisfactorily dealt with. If the fault cannot be corrected immediately but it is necessary to continue operation, an adequate temporary solution shall be used. This shall be reported to the owner of the equipment so all parties are advised.

Initial safety checks shall include that:

- capacitors are discharged: this shall be done in a safe manner to avoid possibility of sparking;
- no live electrical components and wiring are exposed while charging, recovering or purging the system;
- there is continuity of earth bonding

(2) Repairs to Sealed Components

Sealed electrical components shall be replaced.

(3) Repair to intrinsically Safe Components

Intrinsically safe components must be replaced.

(4) Cabling

Check that cabling will not be subject to wear, corrosion, excessive pressure, vibration, sharp edges or any other adverse environmental effects. The check shall also take into account the effects of aging or continual vibration from sources such as compressors or fans.

(5) Detection of Flammable Refrigerants

Under no circumstances shall potential sources of ignition be used in the searching for or detection of refrigerant leaks. A halide torch (or any other detector using a naked flame) shall not be used.

(6) Leak Detection Methods

Electronic leak detectors may be used to detect refrigerant leaks but, in the case of flammable refrigerants, the sensitivity may not be adequate, or may need re-calibration. (Detection equipment shall be calibrated in a refrigerant-free area.) Ensure that the detector is not a potential source of ignition and is suitable for the refrigerant used. Leak detection equipment shall be set at a percentage of the LFL of the refrigerant and shall be calibrated to the refrigerant employed, and the appropriate percentage of gas (25% maximum) is confirmed.

Leak detection fluids are suitable for use with most refrigerants but the use of detergents containing chlorine shall be avoided as the chlorine may react with the refrigerant and corrode the copper pipe-work.

If a leak is suspected, all naked flames shall be removed/extinguished.

If a leakage of refrigerant is found which requires brazing, all of the refrigerant shall be recovered from the system, or isolated (by means of shut off valves) in a part of the system remote from the leak. For appliances containing flammable refrigerants, oxygen free nitrogen (OFN) shall then be purged through the system both before and during the brazing process.

(7) Removal and Evacuation

When breaking into the refrigerant circuit to make repairs - or for any other purpose - conventional procedures shall be used. However, for flammable refrigerants it is important that best practice be followed, since flammability is a consideration. The following procedure shall be adhered to:

- safely remove refrigerant following local and national regulations;
- evacuate;
- purge the circuit with inert gas;
- evacuate;
- purge the circuit again with inert gas; and
- open the circuit.

The refrigerant charge shall be recovered into the correct recovery cylinders if venting is not allowed by local and national codes. For appliances containing flammable refrigerants, the system shall be purged with oxygen-free nitrogen to render the appliance safe for flammable refrigerants. This process might need to be repeated several times.

Compressed air or oxygen shall not be used for purging refrigerant systems. For appliances containing flammable refrigerants, refrigerants purging shall be achieved by breaking the vacuum in the system with oxygen-free nitrogen and continuing to fill until the working pressure is achieved, then venting to atmosphere, and finally pulling down to a vacuum.

This process shall be repeated until no refrigerant is within the system. When the final oxygen-free nitrogen charge is used, the system shall be vented down to atmospheric pressure to enable work to take place. The outlet for the vacuum pump shall not be close to any potential ignition sources, and ventilation shall be available.

(8) Charging Procedures

In addition to conventional charging procedures, the following requirements shall be followed:

- Ensure that contamination of different refrigerants does not occur when using charging equipment. Hoses or lines shall be as short as possible to minimize the amount of refrigerant contained in them.
- Cylinders shall be kept upright.
- Ensure that the refrigeration system is earthed prior to charging the system with refrigerant.
- Label the system when charging is complete (if not already).
- Extreme care shall be taken not to overfill the refrigeration system.

Prior to recharging the system, it shall be pressure-tested with the appropriate purging gas. The system shall be leak-tested on completion of charging but prior to commissioning. A follow up leak test shall be carried out prior to leaving the site.

(9) Decommissioning

Before carrying out this procedure, it is essential that the technician is completely familiar with the equipment and all its detail. It is recommended good practice that all refrigerants are recovered safely. Prior to the task being carried out, an oil and refrigerant sample shall be taken in case analysis is required prior to re-use of reclaimed refrigerant. It is essential that electrical power is available before the task is commenced.

(9-1) Become familiar with the equipment and its operation.

(9-2) Isolate system electrically.

(9-3) Before attempting the procedure, ensure that:

- mechanical handling equipment is available, if required, for handling refrigerant cylinders;
- all personal protective equipment is available and being used correctly;
- the recovery process is supervised at all times by a competent person;
- recovery equipment and cylinders conform to the appropriate standards.

(9-4) Pump down refrigerant system, if possible.

(9-5) If a vacuum is not possible, make a manifold so that refrigerant can be removed from various parts of the system.

(9-6) Make sure that cylinder is situated on the scales before recovery takes place.

(9-7) Start the recovery machine and operate in accordance with manufacturer's instructions.

(9-8) Do not overfill cylinders. (No more than 80 % volume liquid charge).

(9-9) Do not exceed the maximum working pressure of the cylinder, even temporarily.

(9-10) When the cylinders have been filled correctly and the process completed, make sure that the cylinders and the equipment are removed from site promptly and all isolation valves on the equipment are closed off.

(9-11) Recovered refrigerant shall not be charged into another refrigeration system unless it has been cleaned and checked.

(10) Labelling

Equipment shall be labelled stating that it has been de-commissioned and emptied of refrigerant. The label shall be dated and signed. For appliances containing flammable refrigerants, ensure that there are labels on the equipment stating the equipment contains flammable refrigerant.

(11) Recovery

When removing refrigerant from a system, either for servicing or decommissioning, it is recommended good practice that all refrigerants are removed safely.

When transferring refrigerant into cylinders, ensure that only appropriate refrigerant recovery cylinders are employed.

Ensure that the correct number of cylinders for holding the total system charge are available. All cylinders to be used are designated for the recovery refrigerant and labeled for that refrigerant (i.e. special cylinders for the recovery of refrigerant). Cylinders shall be complete with pressure-relief valve and associated shut-off valves in good working order. Empty recovery cylinders are evacuated and, if possible, cooled before recovery occurs.

The recovery equipment shall be in good working order with a set of instructions concerning the equipment that is at hand and shall be suitable for the recovery of the flammable refrigerant. If in doubt, the manufacturer should be consulted. In addition, a set of calibrated weighing scales shall be available and in good working order. Hoses shall be complete with leak-free disconnect couplings and in good condition.

The recovered refrigerant shall be processed according to local legislation in the correct recovery cylinder, and the relevant waste transfer note arranged. Do not mix refrigerants in recovery units and especially not in cylinders.

If compressors or compressor oils are to be removed, ensure that they have been evacuated to an acceptable level to make certain that flammable refrigerant does not remain within the lubricant. The compressor body shall not be heated by an open flame or other ignition sources to accelerate this process. When oil is drained from a system, it shall be carried out safely.

[5] Service tools

(1) Use the below service tools as exclusive tools for R454B refrigerant.

No.	Tool name	Specifications
1	Gauge manifold	·Only for R454B ·Use the existing fitting specifications. (UNF1/2) ·Use high-tension side pressure of 768.7 PSIG [5.3 MPaG] or over.
2	Charge hose	·Only for R454B ·Use pressure performance of 738.2 PSIG [5.09MPaG] or over.
3	Electronic weighing scale	—
4	Gas leak detector	·Use the detector for R134a, R407C, R410A or R454B.
5	Adaptor for reverse flow check	·Attach on vacuum pump.
6	Refrigerant charge base	—
7	Refrigerant cylinder	·Only for R454B ·Cylinder with siphon
8	Refrigerant recovery equipment	—

2-3. CAUTIONS FOR REFRIGERANT PIPING WORK

Refrigerant R454B is adopted for replacement inverter series. Although the refrigerant piping work for R454B is the same as for R22, exclusive tools are necessary so as not to mix with different kind of refrigerant. Furthermore as the working pressure of R454B is 1.5 times higher than that of R22, their sizes of flared sections and flare nuts are different.

① Thickness of pipes

Since the working pressure of R454B is higher compared to R22, be sure to use refrigerant piping with thickness shown below. (Never use pipes of 7/256 in [0.7 mm] or below.)

Diagram below: Piping diameter and thickness

Nominal dimensions (inch)	Outside diameter (mm)	Thickness: in [mm]	
		R454B/R410A	R22
1/4	6.35	1/32 [0.8]	1/32 [0.8]
3/8	9.52	1/32 [0.8]	1/32 [0.8]
1/2	12.70	1/32 [0.8]	1/32 [0.8]
5/8	15.88	5/128 [1.0]	5/128 [1.0]
3/4	19.05	—	5/128 [1.0]

② Dimensions of flare cutting and flare nut

The component molecules in HFC refrigerant are smaller compared to conventional refrigerants. In addition to that, R454B is a refrigerant, which has higher risk of leakage because its working pressure is higher than that of other refrigerants. Therefore, to enhance airtightness and strength, flare cutting dimension of copper pipe for R454B has been specified separately from the dimensions for other refrigerants as shown below. The dimension B of flare nut for R454B also has partly been changed to increase strength as shown below. Set copper pipe correctly referring to copper pipe flaring dimensions for R454B below. For 1/2 and 5/8 inch pipes, the dimension B changes.

Use torque wrench corresponding to each dimension.

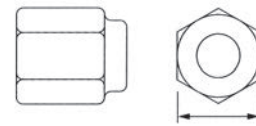
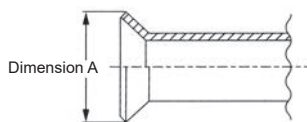

Flare cutting dimensions

Unit: in [mm]

Nominal dimensions (in)	Outside diameter (mm)	Dimension A ($^{+0}_{-0.4}$)	
		R454B/R410A	R22
1/4	6.35	11/32-23/64 [9.1]	9.0
3/8	9.52	1/2-33/64 [13.2]	13.0
1/2	12.70	41/64-21/32 [16.6]	16.2
5/8	15.88	49/64-25/32 [19.7]	19.4
3/4	19.05	—	23.3

Flare nut dimensions

Unit: in [mm]

Nominal dimensions (in)	Outside diameter (mm)	Dimension B	
		R454B/R410A	R22
1/4	6.35	43/64 [17.0]	17.0
3/8	9.52	7/8 [22.0]	22.0
1/2	12.70	1-3/64 [26.0]	24.0
5/8	15.88	1-9/64 [29.0]	27.0
3/4	19.05	—	36.0

③ Tools for R454B (The following table shows whether conventional tools can be used or not.)

Tools and materials	Use	R454B tools	Can R22 tools be used?	Can R407C tools be used?	Can R410A tools be used?
Gauge manifold	Air purge, refrigerant charge and operation check	Tool exclusive for R454B	×	×	○
Charge hose		Tool exclusive for R454B	×	×	○
Gas leak detector	Gas leak check	Tool for HFC refrigerant	×	○	○
Refrigerant recovery equipment	Refrigerant recovery	Tool exclusive for R454B	×	×	○
Refrigerant cylinder	Refrigerant charge	Tool exclusive for R454B	×	×	×
Applied oil	Apply to flared section	Ester oil, ether oil and alkylbenzene oil (minimum amount)	×	Ester oil, ether oil: ○ Alkylbenzene oil: minimum amount	Ester oil: ○ Alkylbenzene oil: minimum amount
Safety charger	Prevent compressor malfunction when charging refrigerant by spraying liquid refrigerant	Tool exclusive for R454B	×	×	×
Charge valve	Prevent gas from blowing out when detaching charge hose	Tool exclusive for R454B	×	×	×
Vacuum pump	Vacuum drying and air purge	Tools for other refrigerants can be used if equipped with adopter for reverse flow check	△ (Usable if equipped with adopter for reverse flow)	△ (Usable if equipped with adopter for reverse flow)	△ (Usable if equipped with adopter for reverse flow)
Flare tool	Flaring work of piping	Tools for other refrigerants can be used by adjusting flaring dimension	△ (Usable by adjusting flaring dimension)	△ (Usable by adjusting flaring dimension)	△ (Usable by adjusting flaring dimension)
Bender	Bend the pipes	Tools for other refrigerants can be used	○	○	○
Pipe cutter	Cut the pipes	Tools for other refrigerants can be used	○	○	○
Welder and nitrogen gas cylinder	Weld the pipes	Tools for other refrigerants can be used	○	○	○
Refrigerant charging scale	Refrigerant charge	Tools for other refrigerants can be used	○	○	○
Vacuum gauge or thermistor vacuum gauge and vacuum valve	Check the degree of vacuum. (Vacuum valve prevents back flow of oil and refrigerant to thermistor vacuum gauge)	Tools for other refrigerants can be used	○	○	○
Charging cylinder	Refrigerant charge	Tool exclusive for R454B	×	—	×

×: Prepare a new tool. (Use the new tool as the tool exclusive for R454B.)

△: Tools for other refrigerants can be used under certain conditions.

○: Tools for other refrigerants can be used.

2-4. CHOOSING THE OUTDOOR UNIT INSTALLATION LOCATION

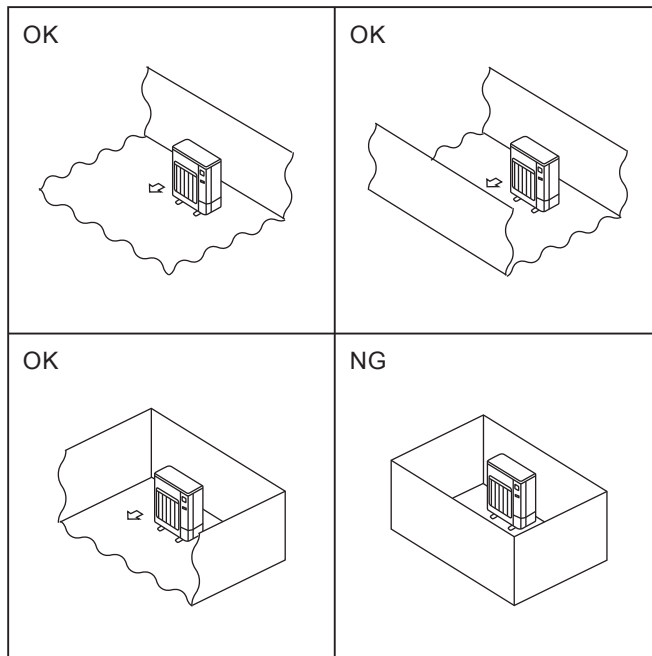

R454B is heavier than air—as well as other refrigerants—so tends to accumulate at the base (in the vicinity of the floor). If R454B accumulates around base, it may reach a flammable concentration in case room is small. To avoid ignition, maintaining a safe work environment is required by ensuring appropriate ventilation. If a refrigerant leak is confirmed in a room or an area where there is insufficient ventilation, refrain from using open flames until the work environment can be improved by ensuring appropriate ventilation.

Install outdoor unit in a place where at least one of the four sides is open, and in a sufficiently large space without depressions.

2.5 PURGING PROCEDURES AND LEAK TEST

- (1) Remove service port cap of stop valve on the side of the outdoor unit gas pipe. (The stop valves are fully closed and covered in caps in their initial state.)
- (2) Connect gauge manifold valve and vacuum pump to service port of stop valve on the gas pipe side of the outdoor unit.
- (3) Evacuate the system to 4000 microns from both service valves. System manifold gauges must not be used to measure vacuum. A micron gauge must be used at all times. Break the vacuum with Nitrogen(N₂) into the discharge service valve to 0 psig [0 MPa].
- (4) Evacuate the system to 1500 microns. Break the vacuum with Nitrogen(N₂) into the discharge service valve to 0 psig [0 MPa].
- (5) Evacuate the system to 500 microns.
- (6) Close gauge manifold valves, stop the pump, and conduct a 30 minute rise test.
- (7) System should hold 500 microns for a minimum of 1 hour.
- (8) Fully open the valve stem of all stop valves on both sides of gas pipe and liquid pipe by the hexagonal wrench. If the valve stem hits the stopper, do not turn it any further. Operating without fully opening lowers the performance and this causes trouble.
- (9) Remove gauge manifolds and replace service port caps and tighten.
- (10) Leak test

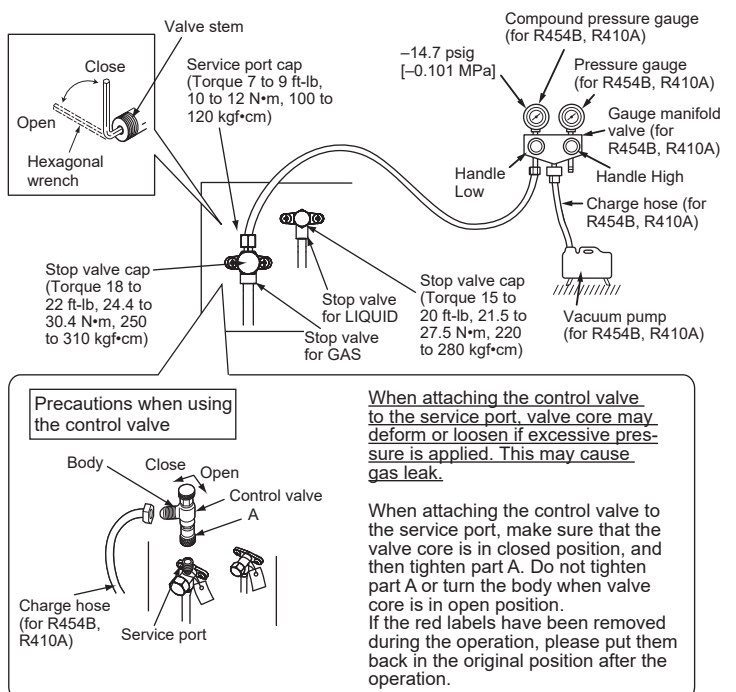

Refrigerant pipe airtight testing method

- (1) Connect the testing tools.
 - Make sure the stop valves are closed and do not open them.
 - Add pressure to the refrigerant lines through the service port of the stop valve for GAS.
- (2) Do not add pressure to the specified pressure all at once; add pressure little by little.
 - 1 Pressurize to 73 psig [0.5 MPa], wait 5 minutes, and make sure the pressure dose not decrease.
 - 2 Pressurize to 218 psig [1.5 MPa], wait 5 minutes, and make sure the pressure dose not decrease.
 - 3 Pressurize to 602 psig [4.15 MPa] and measure the surrounding temperature and refrigerant pressure.
- (3) If the specified pressure holds for 24 hours and does not decrease, the pipes have passed the test and there are no leaks.
 - If the surrounding temperature changes by 1.8°F [1°C], the pressure will change by about 1.5 psig [0.01 MPa]. Make the necessary corrections.
- (4) If the pressure decreases in steps (2) or (3), there is a gas leak. Look for the source of the gas leak.

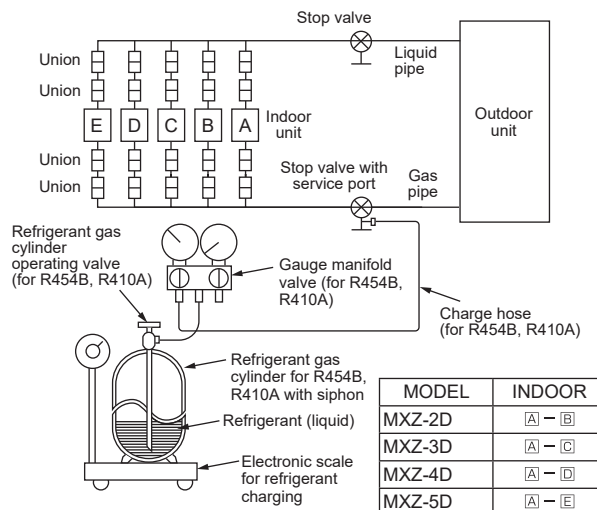

NOTE:

- Field-made refrigerant joints indoors shall be tightness tested. The test method shall have a sensitivity of 5 grams per year of refrigerant or better under a pressure of at least 0.25 times the MAXIMUM ALLOWABLE PRESSURE. No leak shall be detected.

NOTE:

Detection of flammable refrigerants

Under no circumstances shall potential sources of ignition be used in the searching for or detection of refrigerant leaks. A halide torch (or any other detector using a naked flame) shall not be used.

The following leak detection methods are deemed acceptable for all refrigerant systems.

Electronic leak detectors may be used to detect refrigerant leaks but, in the case of flammable refrigerants, the sensitivity may not be adequate, or may need recalibration. (Detection equipment shall be calibrated in a refrigerant-free area.)

Ensure that the detector is not a potential source of ignition and is suitable for the refrigerant used. Leak detection equipment shall be set at a percentage of the LFL of the refrigerant and shall be calibrated to the refrigerant employed, and the appropriate percentage of gas (25 % maximum) is confirmed.

Leak detection fluids are also suitable for use with most refrigerants but the use of detergents containing chlorine shall be avoided as the chlorine may react with the refrigerant and corrode the copper pipe-work.

If a leak is suspected, all naked flames shall be removed/extinguished.

If a leakage of refrigerant is found which requires brazing, all of the refrigerant shall be recovered from the system, or isolated (by means of shut off valves) in a part of the system remote from the leak.

Charging procedures

In addition to conventional charging procedures, the following requirements shall be followed.

- Ensure that contamination of different refrigerants does not occur when using charging equipment. Hoses or lines shall be as short as possible to minimise the amount of refrigerant contained in them.
- Cylinders shall be kept in an appropriate position according to the instructions.
- Ensure that the refrigerating system is earthed prior to charging the system with refrigerant.
- Label the system when charging is complete (if not already).
- Extreme care shall be taken not to overfill the refrigerating system.

Prior to recharging the system, it shall be pressure-tested with the appropriate purging gas. The system shall be leak-tested on completion of charging but prior to commissioning. A follow up leak test shall be carried out prior to leaving the site.

2-6. MINIMUM INSTALLATION AREA FOR INDOOR UNITS

Install in a room with a floor area of A_{min} or more, corresponding to refrigerant quantity M (factory-charged refrigerant + locally added refrigerant).

* For the factory-charged refrigerant amount, refer to the spec nameplate or installation manual.

For the amount to be added locally, refer to the installation manual.

Install the indoor unit so that the height from the floor to the bottom of the indoor unit is h_0 ;

for wall mounted: 6 [ft.] (1.8 [m]) or more;

for ceiling suspended, cassette and ceiling concealed: 8.2 [ft.] (2.5 [m]) or more.

When installing floor standing or ducted indoor unit, refer to indoor unit Installation manual.

There are restrictions in installation height for each model, so read the installation manual for the particular unit.

For wall mounted, ceiling suspended, cassette and concealed

M			A_{min}	
[kg]	[lbs, oz]		[m ²]	[ft ²]
0.5	1	1	1.9	21
0.6	1	5	2.3	25
0.7	1	8	2.6	28
0.8	1	12	3.0	33
0.9	1	15	3.4	37
1.0	2	3	3.8	41
1.1	2	6	4.1	45
1.2	2	10	4.5	49
1.3	2	13	4.9	53
1.4	3	1	5.2	56
1.5	3	4	5.6	61
1.6	3	8	6.0	65
1.7	3	11	6.3	68
1.8	3	15	6.8	74
1.9	4	3	7.2	78
2.0	4	6	7.6	82
2.1	4	10	7.9	86
2.2	4	13	8.3	90
2.3	5	1	8.7	94
2.4	5	4	9.1	98
2.5	5	8	9.4	102
2.6	5	11	9.8	106
2.7	5	15	10.2	110
2.8	6	2	10.6	115

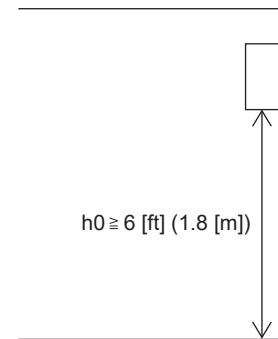

Wall mounted

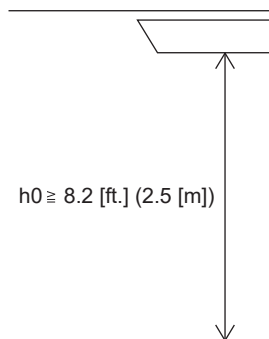

Ceiling suspended

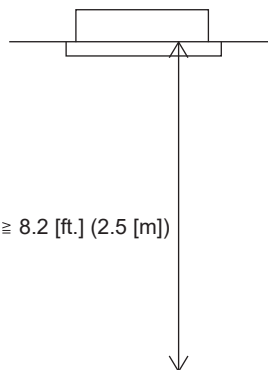

Cassette

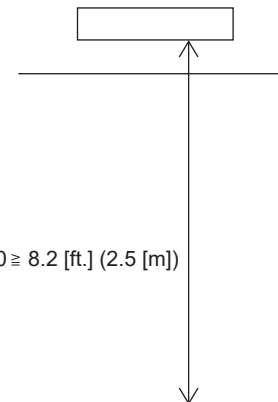

Ceiling concealed

MXZ-2D20NL

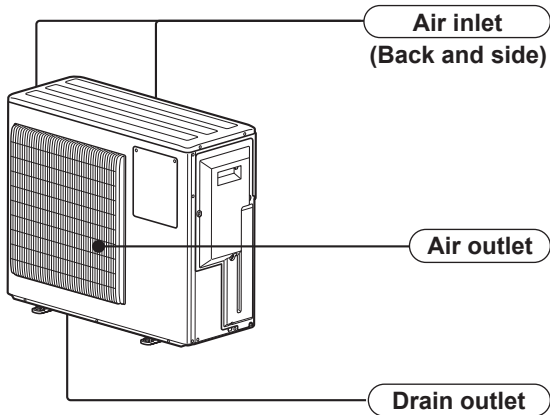

MXZ-3D24NL

MXZ-4D30NL

MXZ-2D20NLHZ

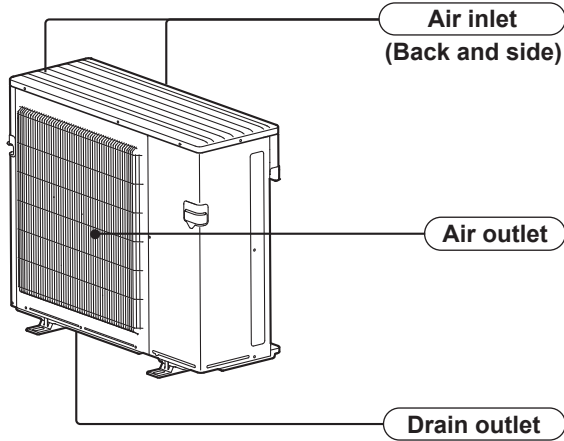

MXZ-5D36NL

MXZ-5D42NL

MXZ-3D24NLHZ

MXZ-3D30NLHZ

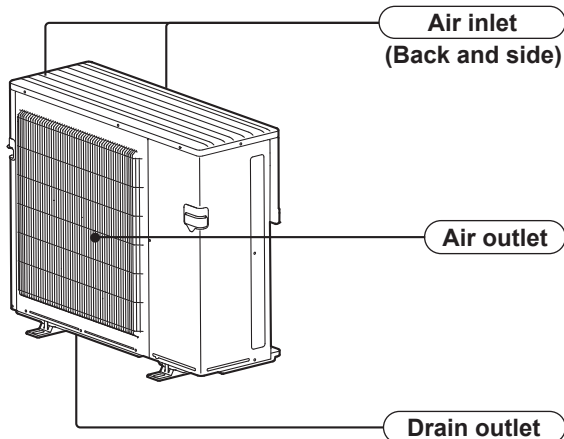

4

SPECIFICATION

Item		Outdoor model	MXZ-2D20NL	
		Indoor type	Non-Duct (09+09)	Duct (09+12)
Capacity	Cooling	Btu/h	18,000	20,000
	Heating 47	Btu/h	22,000	22,000
	Heating 17	Btu/h	16,500	13,500
Power consumption	Cooling	W	1,384	2,000
	Heating 47	W	1,641	1,771
	Heating 17	W	1,691	1,500
EER2	Cooling		13.00	10.00
SEER2	Cooling		20.00	16.00
HSPF2 IV(V)	Heating		10.00 (8.40)	9.10 (7.50)
COP	Heating		3.92	3.64
External finish			Munsell 3.0Y 7.8/1.1	
Power supply		V, phase, Hz	208/230, 1, 60	
Max. fuse size (time delay)		A	38	
Min. circuit ampacity		A	21.7	
Fan motor input		A	0.22	
Compressor	Model		SRB140FQHM1T	
	Winding resistance (at 68 °F)	Ω	U-V 1.56 V-W 1.56 W-U 1.56	
Inverter input		A	14.4	
Refrigerant control			LEV	
Sound level		dB(A)	51/55	
Defrost method			Reverse cycle	
Dimensions	W	in.	33-1/16	
	D	in.	13	
	H	in.	27-15/16	
Weight		lb.	119	
Remote controller			Wireless type	Wired type
Control voltage (by built-in transformer)			12 - 24 V DC	
Refrigerant piping			Not supplied (optional parts)	
Valve size	Liquid	in.	1/4	
	Gas	in.	3/8	
Connection method	Indoor		Flared	
	Outdoor		Flared	
Refrigerant charge (R454B)		lb.	4 lb. 7 oz.	
Refrigeration oil (Model)		fl oz. (L)	20.3 (0.6) (RM68EH)	

NOTE: Test conditions are based on AHRI 210/240.

Function	Condition	Intake air temperature		Indoor		Outdoor	
		DB (°F)	WB (°F)	DB (°F)	WB (°F)	DB (°F)	WB (°F)
Cooling	"A _{Full} " Cooling steady state at rated compressor speed	80	67	95	(75)		
	"B _{Full} " Cooling steady state at rated compressor speed	80	67	82	(65)		
	"B _{Low} " Cooling steady state at minimum compressor speed	80	67	82	(65)		
	Low ambient cooling steady state at minimum compressor speed	80	67	67	(53.5)		
	Intermediate cooling steady state at intermediate compressor speed	80	67	87	(69)		
Heating	Standard rating-heating at rated compressor speed	70	60	47	43		
	Low temperature heating at rated compressor speed	70	60	17	15		
	Max. temperature heating at minimum compressor speed	70	60	62	56.5		
	High temperature heating at minimum compressor speed	70	60	47	43		
	Frost accumulation at intermediate compressor speed	70	60	35	33		
Very low temperature heating at maximum compressor speed	70	60	5	4			

Item		Outdoor model	MXZ-3D24NL	
		Indoor type	Non-Duct (06+09+09)	Duct (12+12)
Capacity	Cooling	Btu/h	22,000	23,600
	Heating 47	Btu/h	25,000	25,400
	Heating 17	Btu/h	15,500	16,000
Power consumption	Cooling	W	1,605	2,017
	Heating 47	W	1,704	1,909
	Heating 17	W	1,465	1,711
EER2	Cooling		13.70	11.70
SEER2	Cooling		20.00	16.00
HSPF2 IV(V)	Heating		10.00 (7.60)	8.60 (7.40)
COP	Heating		4.30	3.90
External finish			Munsell 3.0Y 7.8/1.1	
Power supply		V, phase, Hz	208/230, 1, 60	
Max. fuse size (time delay)		A	48	
Min. circuit ampacity		A	28.7	
Fan motor input		A	0.40	
Compressor	Model		SRB220FQYMC-L	
	Winding resistance (at 68 °F)	Ω	U-V 0.72 V-W 0.72 W-U 0.72	
Inverter input		A	18.4	
Refrigerant control			LEV	
Sound level		dB(A)	51/55	
Defrost method			Reverse cycle	
Dimensions	W	in.	37-11/32	
	D	in.	13	
	H	in.	31-11/32	
Weight		lb.	137	
Remote controller			Wireless type	Wired type
Control voltage (by built-in transformer)			12 - 24 V DC	
Refrigerant piping			Not supplied (optional parts)	
Valve size	Liquid	in.	1/4	
	Gas	in.	A:1/2, B, C: 3/8	
Connection method	Indoor		Flared	
	Outdoor		Flared	
Refrigerant charge (R454B)		lb.	5lbs., 5oz	
Refrigeration oil (Model)		fl oz. (L)	20.3 (0.6) (RM68EH)	

NOTE: Test conditions are based on AHRI 210/240.

Function	Condition	Intake air temperature	Indoor		Outdoor	
			DB (°F)	WB (°F)	DB (°F)	WB (°F)
Cooling	"A _{Full} " Cooling steady state at rated compressor speed		80	67	95	(75)
	"B _{Full} " Cooling steady state at rated compressor speed		80	67	82	(65)
	"B _{Low} " Cooling steady state at minimum compressor speed		80	67	82	(65)
	Low ambient cooling steady state at minimum compressor speed		80	67	67	(53.5)
	Intermediate cooling steady state at intermediate compressor speed		80	67	87	(69)
Heating	Standard rating-heating at rated compressor speed		70	60	47	43
	Low temperature heating at rated compressor speed		70	60	17	15
	Max. temperature heating at minimum compressor speed		70	60	62	56.5
	High temperature heating at minimum compressor speed		70	60	47	43
	Frost accumulation at intermediate compressor speed		70	60	35	33
	Very low temperature heating at maximum compressor speed		70	60	5	4



Item		Outdoor model	MXZ-4D30NL	
		Indoor type	Non-Duct (06+06+09+09)	Duct (18+18)
Capacity	Cooling	Btu/h	28,600	27,400
	Heating 47	Btu/h	28,600	27,600
	Heating 17	Btu/h	18,200	17,800
Power consumption	Cooling	W	2,200	2,854
	Heating 47	W	2,149	2,200
	Heating 17	W	1,667	1,837
EER2	Cooling		13.00	9.60
SEER2	Cooling		21.00	16.10
HSPF2 IV(V)	Heating		10.00 (7.90)	8.80 (7.40)
COP	Heating		3.90	3.68
External finish			Munsell 3.0Y 7.8/1.1	
Power supply		V, phase, Hz	208/230, 1, 60	
Max. fuse size (time delay)		A	48	
Min. circuit ampacity		A	28.7	
Fan motor input		A	0.40	
Compressor	Model		SRB220FQYMC-L	
	Winding resistance (at 68 °F)	Ω	U-V 0.72 V-W 0.72 W-U 0.72	
Inverter input		A	18.4	
Refrigerant control			LEV	
Sound level		dB(A)	53/56	
Defrost method			Reverse cycle	
Dimensions	W	in.	37-13/32	
	D	in.	13	
	H	in.	31-11/32	
Weight		lb.	137	
Remote controller			Wireless type	Wired type
Control voltage (by built-in transformer)			12 - 24 V DC	
Refrigerant piping			Not supplied (optional parts)	
Valve size	Liquid	in.	1/4	
	Gas	in.	A: 1/2, B, C, D: 3/8	
Connection method	Indoor		Flared	
	Outdoor		Flared	
Refrigerant charge (R454B)		lb.	5lbs., 5oz	
Refrigeration oil (Model)		fl oz. (L)	20.3 (0.6) (RM68EH)	

NOTE: Test conditions are based on AHRI 210/240.

Function	Condition	Intake air temperature	Indoor		Outdoor	
			DB (°F)	WB (°F)	DB (°F)	WB (°F)
Cooling	"A _{Full} " Cooling steady state at rated compressor speed		80	67	95	(75)
	"B _{Full} " Cooling steady state at rated compressor speed		80	67	82	(65)
	"B _{Low} " Cooling steady state at minimum compressor speed		80	67	82	(65)
	Low ambient cooling steady state at minimum compressor speed		80	67	67	(53.5)
	Intermediate cooling steady state at intermediate compressor speed		80	67	87	(69)
Heating	Standard rating-heating at rated compressor speed		70	60	47	43
	Low temperature heating at rated compressor speed		70	60	17	15
	Max. temperature heating at minimum compressor speed		70	60	62	56.5
	High temperature heating at minimum compressor speed		70	60	47	43
	Frost accumulation at intermediate compressor speed		70	60	35	33
Very low temperature heating at maximum compressor speed		70	60	5	4	

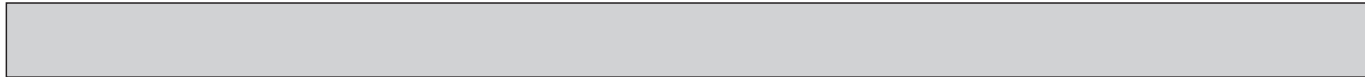

Item		Outdoor model	MXZ-5D36NL	
		Indoor type	Non-Duct (06+06+06+09+09)	Duct (18+18)
Capacity	Cooling	Btu/h	35,400	33,400
	Heating 47	Btu/h	36,000	34,400
	Heating 17	Btu/h	23,000	22,400
Power consumption	Cooling	W	2,950	3,839
	Heating 47	W	3,015	3,093
	Heating 17	W	2,407	2,626
EER2	Cooling		12.00	8.70
SEER2	Cooling		19.20	16.20
HSPF2 IV(V)	Heating		9.30 (7.70)	8.30 (6.30)
COP	Heating		3.26	3.26
External finish			Munsell 3.0Y 7.8/1.1	
Power supply		V, phase, Hz	208/230, 1, 60	
Max. fuse size (time delay)		A	49	
Min. circuit ampacity		A	29	
Fan motor input		A	0.40	
Compressor	Model		SRB280FDRMC	
	Winding resistance (at 68 °F)	Ω	U-V 0.35 V-W 0.35 W-U 0.35	
Inverter input		A	18.6	
Refrigerant control			LEV	
Sound level		dB(A)	58/58	
Defrost method			Reverse cycle	
Dimensions	W	in.	37-13/32	
	D	in.	13	
	H	in.	31-11/32	
Weight		lb.	152	
Remote controller			Wireless type	Wired type
Control voltage (by built-in transformer)			12 - 24 V DC	
Refrigerant piping			Not supplied (optional parts)	
Valve size	Liquid	in.	1/4	
	Gas	in.	A: 1/2, B, C, D, E: 3/8	
Connection method	Indoor		Flared	
	Outdoor		Flared	
Refrigerant charge (R454B)		lb.	6lbs., 3oz	
Refrigeration oil (Model)		fl oz. (L)	23.7 (0.7) (RM68EH)	

NOTE: Test conditions are based on AHRI 210/240.

Function	Condition	Intake air temperature	Indoor		Outdoor	
			DB (°F)	WB (°F)	DB (°F)	WB (°F)
Cooling	"A _{Full} " Cooling steady state at rated compressor speed		80	67	95	(75)
	"B _{Full} " Cooling steady state at rated compressor speed		80	67	82	(65)
	"B _{Low} " Cooling steady state at minimum compressor speed		80	67	82	(65)
	Low ambient cooling steady state at minimum compressor speed		80	67	67	(53.5)
	Intermediate cooling steady state at intermediate compressor speed		80	67	87	(69)
Heating	Standard rating-heating at rated compressor speed		70	60	47	43
	Low temperature heating at rated compressor speed		70	60	17	15
	Max. temperature heating at minimum compressor speed		70	60	62	56.5
	High temperature heating at minimum compressor speed		70	60	47	43
	Frost accumulation at intermediate compressor speed		70	60	35	33
	Very low temperature heating at maximum compressor speed		70	60	5	4



Item		Outdoor model	MXZ-5D42NL	
		Indoor type	Non-Duct (06+09+09+09+09)	Duct (24+24)
Capacity	Cooling	Btu/h	40,500	36,400
	Heating 47	Btu/h	45,000	41,000
	Heating 17	Btu/h	29,000	23,000
Power consumption	Cooling	W	4,355	4,044
	Heating 47	W	4,397	4,517
	Heating 17	W	3,295	3,548
EER2	Cooling		9.30	9.00
SEER2	Cooling		19.30	15.60
HSPF2 IV(V)	Heating		9.10 (7.40)	8.00 (6.40)
COP	Heating		3.00	2.66
External finish			Munsell 3.0Y 7.8/1.1	
Power supply		V, phase, Hz	208/230, 1, 60	
Max. fuse size (time delay)		A	67	
Min. circuit ampacity		A	39.2	
Fan motor input		A	0.40	
Compressor	Model		SRB280FDRMC	
	Winding resistance (at 68 °F)	Ω	U-V 0.35 V-W 0.35 W-U 0.35	
Inverter input		A	26.8	
Refrigerant control			LEV	
Sound level		dB(A)	58/59	
Defrost method			Reverse cycle	
Dimensions	W	in.	37-13/32	
	D	in.	13	
	H	in.	31-11/32	
Weight		lb.	152	
Remote controller			Wireless type	Wired type
Control voltage (by built-in transformer)			12 - 24 V DC	
Refrigerant piping			Not supplied (optional parts)	
Valve size	Liquid	in.	1/4	
	Gas	in.	A: 1/2, B, C, D, E: 3/8	
Connection method	Indoor		Flared	
	Outdoor		Flared	
Refrigerant charge (R454B)		lb.	6lbs., 3oz	
Refrigeration oil (Model)		fl oz. (L)	23.7 (0.7) (RM68EH)	

NOTE: Test conditions are based on AHRI 210/240.

Function	Condition	Intake air temperature		Indoor		Outdoor	
		DB (°F)	WB (°F)	DB (°F)	WB (°F)	DB (°F)	WB (°F)
Cooling	"A _{Full} " Cooling steady state at rated compressor speed	80	67	95	(75)		
	"B _{Full} " Cooling steady state at rated compressor speed	80	67	82	(65)		
	"B _{Low} " Cooling steady state at minimum compressor speed	80	67	82	(65)		
	Low ambient cooling steady state at minimum compressor speed	80	67	67	(53.5)		
	Intermediate cooling steady state at intermediate compressor speed	80	67	87	(69)		
Heating	Standard rating-heating at rated compressor speed	70	60	47	43		
	Low temperature heating at rated compressor speed	70	60	17	15		
	Max. temperature heating at minimum compressor speed	70	60	62	56.5		
	High temperature heating at minimum compressor speed	70	60	47	43		
	Frost accumulation at intermediate compressor speed	70	60	35	33		
Very low temperature heating at maximum compressor speed	70	60	5	4			

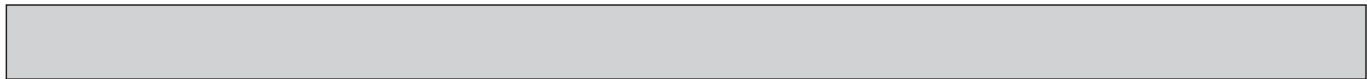

Item		Outdoor model	MXZ-2D20NLHZ	
		Indoor type	Non-Duct (09+09)	Duct (09+12)
Capacity	Cooling	Btu/h	18,000	20,000
	Heating 47	Btu/h	22,000	22,000
	Heating 17	Btu/h	14,300	12,500
Power consumption	Cooling	W	1,333	1,802
	Heating 47	W	1,612	1,688
	Heating 17	W	1,518	1,500
EER2	Cooling		13.50	11.10
SEER2	Cooling		19.30	14.30
HSPF2 IV(V)	Heating		10.00 (8.60)	7.90 (6.60)
COP	Heating		4.00	3.82
External finish			Munsell 3.0Y 7.8/1.1	
Power supply		V, phase, Hz	208/230, 1, 60	
Max. fuse size (time delay)		A	38	
Min. circuit ampacity		A	21.7	
Fan motor input		A	0.40	
Compressor	Model		SRB220FQYMC-L	
	Winding resistance (at 68 °F)	Ω	U-V 0.72 V-W 0.72 W-U 0.72	
Inverter input		A	14.4	
Refrigerant control			LEV	
Sound level		dB(A)	51/53	
Defrost method			Reverse cycle	
Dimensions	W	in.	37-13/32	
	D	in.	13	
	H	in.	31-11/32	
Weight		lb.	137	
Remote controller			Wireless type	Wired type
Control voltage (by built-in transformer)			12 - 24 V DC	
Refrigerant piping			Not supplied (optional parts)	
Valve size	Liquid	in.	1/4	
	Gas	in.	3/8	
Connection method	Indoor		Flared	
	Outdoor		Flared	
Refrigerant charge (R454B)		lb.	5lbs., 5oz	
Refrigeration oil (Model)		fl oz. (L)	20.3 (0.6) (RM68EH)	

NOTE: Test conditions are based on AHRI 210/240.

Function	Condition	Intake air temperature	Indoor		Outdoor	
			DB (°F)	WB (°F)	DB (°F)	WB (°F)
Cooling	"A _{Full} " Cooling steady state at rated compressor speed		80	67	95	(75)
	"B _{Full} " Cooling steady state at rated compressor speed		80	67	82	(65)
	"B _{Low} " Cooling steady state at minimum compressor speed		80	67	82	(65)
	Low ambient cooling steady state at minimum compressor speed		80	67	67	(53.5)
	Intermediate cooling steady state at intermediate compressor speed		80	67	87	(69)
Heating	Standard rating-heating at rated compressor speed		70	60	47	43
	Low temperature heating at rated compressor speed		70	60	17	15
	Max. temperature heating at minimum compressor speed		70	60	62	56.5
	High temperature heating at minimum compressor speed		70	60	47	43
	Frost accumulation at intermediate compressor speed		70	60	35	33
	Very low temperature heating at maximum compressor speed		70	60	5	4

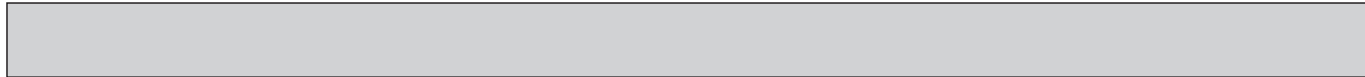

Item		Outdoor model	MXZ-3D24NLHZ	
		Indoor type	Non-Duct (06+09+09)	Duct (12+12)
Capacity	Cooling	Btu/h	22,000	23,600
	Heating 47	Btu/h	25,000	24,600
	Heating 17	Btu/h	15,400	15,000
Power consumption	Cooling	W	1,693	2,360
	Heating 47	W	2,094	1,949
	Heating 17	W	1,590	1,954
EER2	Cooling		13.00	10.00
SEER2	Cooling		20.00	14.40
HSPF2 IV(V)	Heating		10.00 (8.00)	8.00 (6.20)
COP	Heating		3.50	3.70
External finish			Munsell 3.0Y 7.8/1.1	
Power supply		V, phase, Hz	208/230, 1, 60	
Max. fuse size (time delay)		A	49	
Min. circuit ampacity		A	29	
Fan motor input		A	0.40	
Compressor	Model		SRB280FDRMC	
	Winding resistance (at 68 °F)	Ω	U-V 0.35 V-W 0.35 W-U 0.35	
Inverter input		A	18.6	
Refrigerant control			LEV	
Sound level		dB(A)	56/58	
Defrost method			Reverse cycle	
Dimensions	W	in.	37-13/32	
	D	in.	13	
	H	in.	31-11/32	
Weight		lb.	152	
Remote controller			Wireless type	Wired type
Control voltage (by built-in transformer)			12 - 24 V DC	
Refrigerant piping			Not supplied (optional parts)	
Valve size	Liquid	in.	1/4	
	Gas	in.	A: 1/2, B, C: 3/8	
Connection method	Indoor		Flared	
	Outdoor		Flared	
Refrigerant charge (R454B)		lb.	6lbs., 3oz	
Refrigeration oil (Model)		fl oz. (L)	23.7 (0.7) (RM68EH)	

NOTE: Test conditions are based on AHRI 210/240.

Function	Condition	Intake air temperature		Indoor		Outdoor	
		DB (°F)	WB (°F)	DB (°F)	WB (°F)	DB (°F)	WB (°F)
Cooling	"A _{Full} " Cooling steady state at rated compressor speed	80	67	95	(75)		
	"B _{Full} " Cooling steady state at rated compressor speed	80	67	82	(65)		
	"B _{Low} " Cooling steady state at minimum compressor speed	80	67	82	(65)		
	Low ambient cooling steady state at minimum compressor speed	80	67	67	(53.5)		
	Intermediate cooling steady state at intermediate compressor speed	80	67	87	(69)		
Heating	Standard rating-heating at rated compressor speed	70	60	47	43		
	Low temperature heating at rated compressor speed	70	60	17	15		
	Max. temperature heating at minimum compressor speed	70	60	62	56.5		
	High temperature heating at minimum compressor speed	70	60	47	43		
	Frost accumulation at intermediate compressor speed	70	60	35	33		
Very low temperature heating at maximum compressor speed	70	60	5	4			

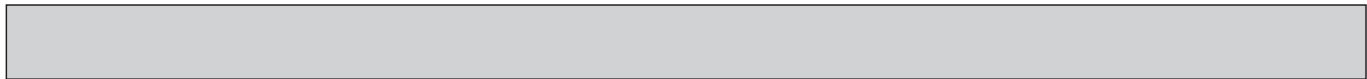

Item		Outdoor model	MXZ-3D30NLHZ	
		Indoor type	Non-Duct (09+09+12)	Duct (18+18)
Capacity	Cooling	Btu/h	28,400	27,400
	Heating 47	Btu/h	28,600	27,600
	Heating 17	Btu/h	18,300	19,000
Power consumption	Cooling	W	2,470	2,660
	Heating 47	W	2,395	2,285
	Heating 17	W	1,916	2,282
EER2	Cooling		11.50	10.3
SEER2	Cooling		20.00	16.0
HSPF2 IV(V)	Heating		10.00 (8.00)	8.00 (6.20)
COP	Heating		3.50	3.54
External finish			Munsell 3.0Y 7.8/1.1	
Power supply		V, phase, Hz	208/230, 1, 60	
Max. fuse size (time delay)		A	65	
Min. circuit ampacity		A	38	
Fan motor input		A	0.40	
Compressor	Model		SRB280FDRMC	
	Winding resistance (at 68 °F)	Ω	U-V 0.35 V-W 0.35 W-U 0.35	
Inverter input		A	25.8	
Refrigerant control			LEV	
Sound level		dB(A)	56/58	
Defrost method			Reverse cycle	
Dimensions	W	in.	37-13/32	
	D	in.	13	
	H	in.	31-11/32	
Weight		lb.	152	
Remote controller			Wireless type	Wired type
Control voltage (by built-in transformer)			12 - 24 V DC	
Refrigerant piping			Not supplied (optional parts)	
Valve size	Liquid	in.	1/4	
	Gas	in.	A: 1/2, B, C: 3/8	
Connection method	Indoor		Flared	
	Outdoor		Flared	
Refrigerant charge (R454B)		lb.	6lbs., 3oz	
Refrigeration oil (Model)		fl oz. (L)	23.7 (0.7) (RM68EH)	

NOTE: Test conditions are based on AHRI 210/240.

Function	Condition	Intake air temperature	Indoor		Outdoor	
			DB (°F)	WB (°F)	DB (°F)	WB (°F)
Cooling	"A _{Full} " Cooling steady state at rated compressor speed		80	67	95	(75)
	"B _{Full} " Cooling steady state at rated compressor speed		80	67	82	(65)
	"B _{Low} " Cooling steady state at minimum compressor speed		80	67	82	(65)
	Low ambient cooling steady state at minimum compressor speed		80	67	67	(53.5)
	Intermediate cooling steady state at intermediate compressor speed		80	67	87	(69)
Heating	Standard rating-heating at rated compressor speed		70	60	47	43
	Low temperature heating at rated compressor speed		70	60	17	15
	Max. temperature heating at minimum compressor speed		70	60	62	56.5
	High temperature heating at minimum compressor speed		70	60	47	43
	Frost accumulation at intermediate compressor speed		70	60	35	33
	Very low temperature heating at maximum compressor speed		70	60	5	4

5

NOISE CRITERIA CURVES

MXZ-2D20NL

FAN SPEED	FUNCTION	SPL(dB(A))	LINE
High	Cooling	51	●—●
High	Heating	55	○—○

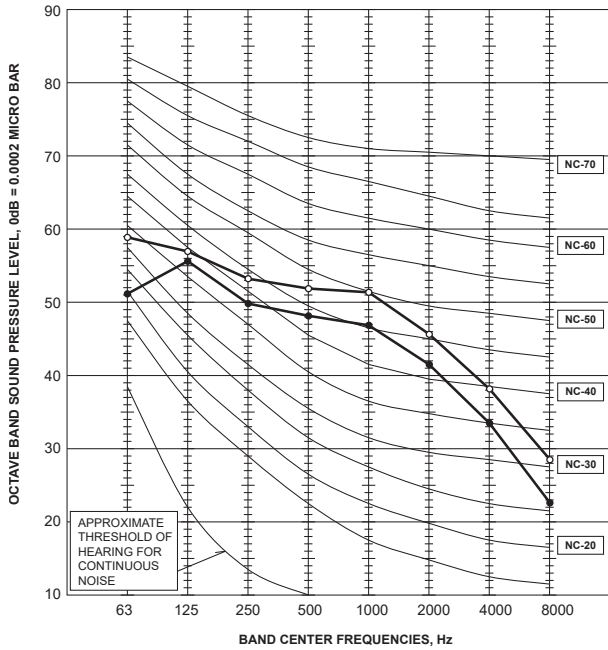

MXZ-3D24NL

FAN SPEED	FUNCTION	SPL(dB(A))	LINE
High	Cooling	51	●—●
High	Heating	55	○—○

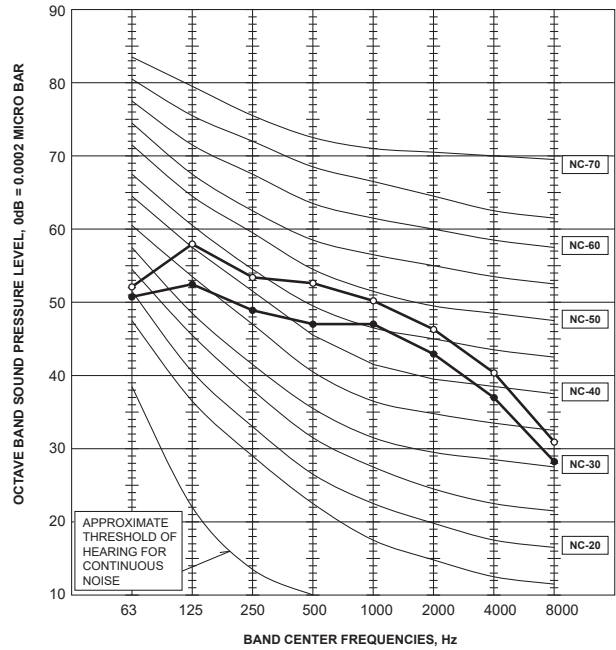

MXZ-4D30NL

FAN SPEED	FUNCTION	SPL(dB(A))	LINE
High	Cooling	53	●—●
High	Heating	56	○—○

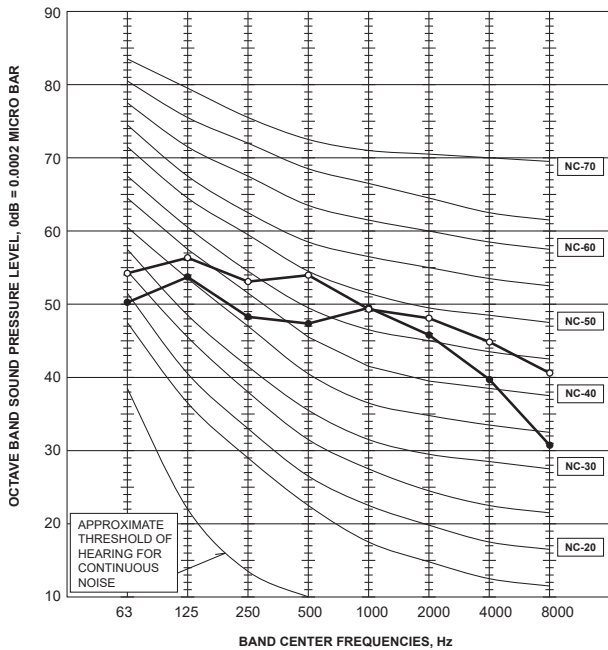

MXZ-5D36NL

FAN SPEED	FUNCTION	SPL(dB(A))	LINE
High	Cooling	58	●—●
High	Heating	58	○—○

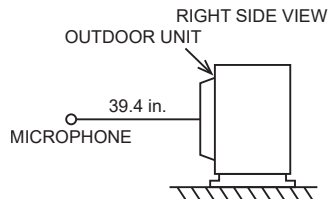
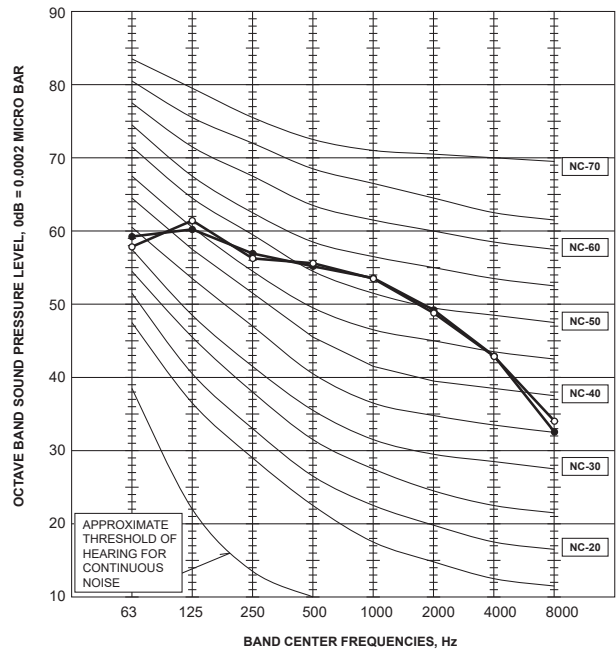

Test conditions

Cooling: Dry-bulb temperature 95°F Wet-bulb temperature 75°F
 Heating: Dry-bulb temperature 45°F Wet-bulb temperature 43°F

MXZ-5D42NL

FAN SPEED	FUNCTION	SPL(dB(A))	LINE
High	Cooling	58	●—●
High	Heating	59	○—○

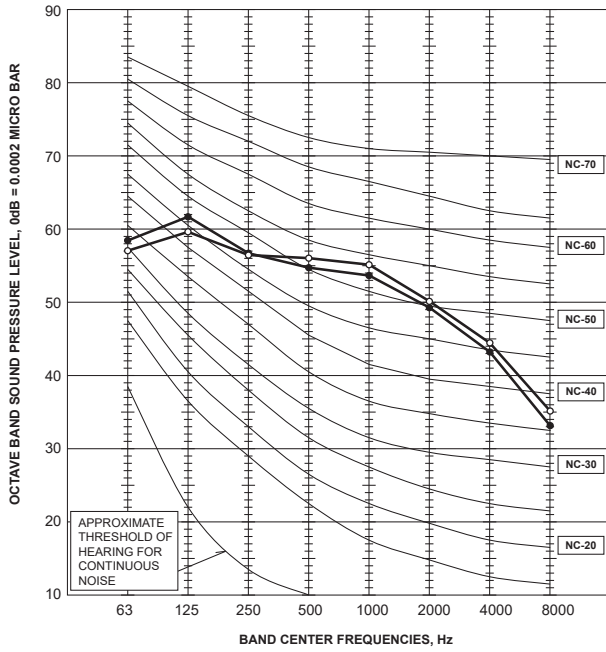

MXZ-2D20NLHZ

FAN SPEED	FUNCTION	SPL(dB(A))	LINE
High	Cooling	51	●—●
High	Heating	53	○—○

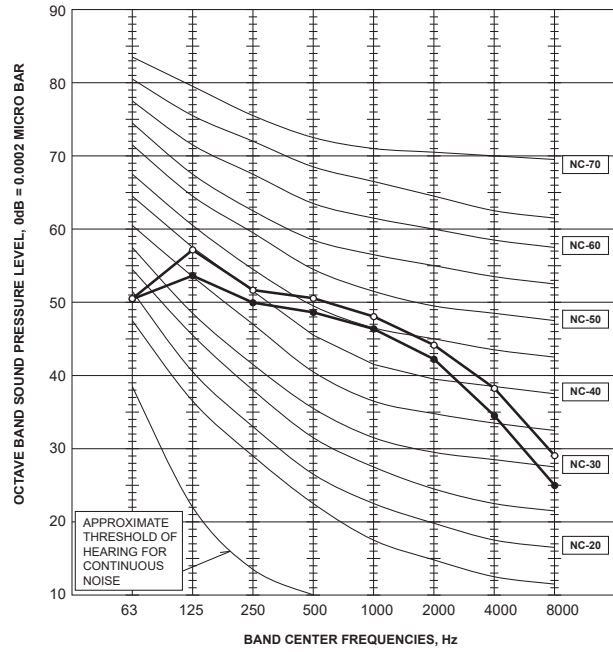

MXZ-3D24NLHZ

FAN SPEED	FUNCTION	SPL(dB(A))	LINE
High	Cooling	56	●—●
High	Heating	58	○—○

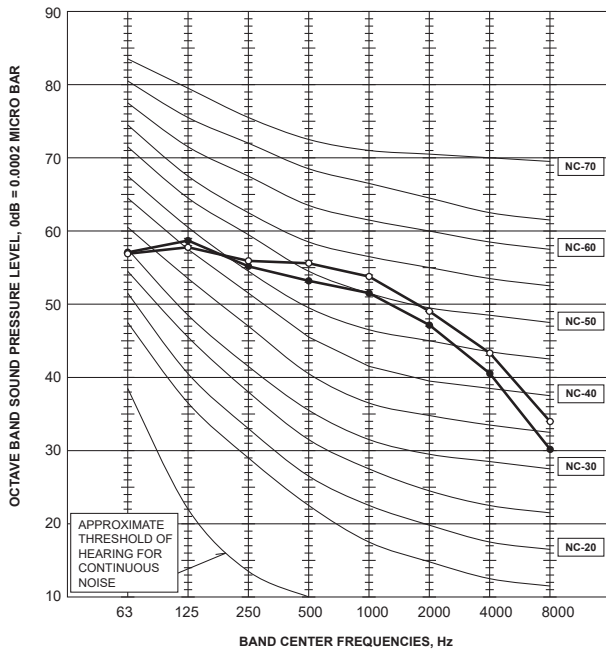

MXZ-3D30NLHZ

FAN SPEED	FUNCTION	SPL(dB(A))	LINE
High	Cooling	56	●—●
High	Heating	58	○—○

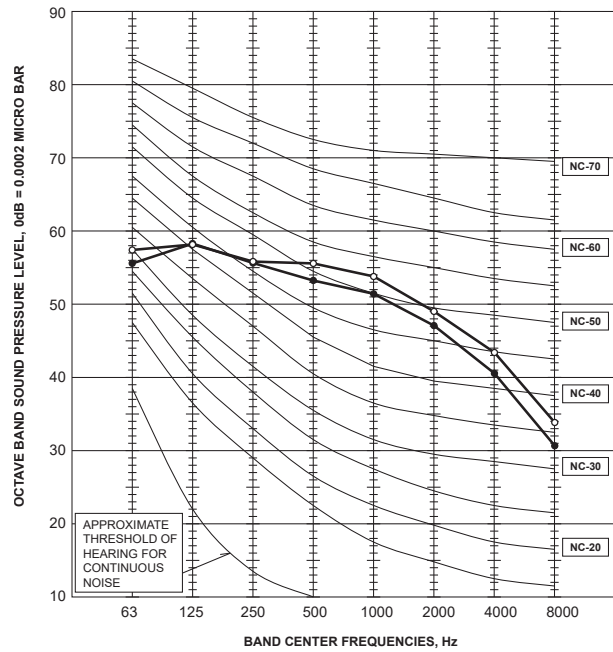

6

OUTLINES AND DIMENSIONS

MXZ-2D20NL

Unit: inch (mm)

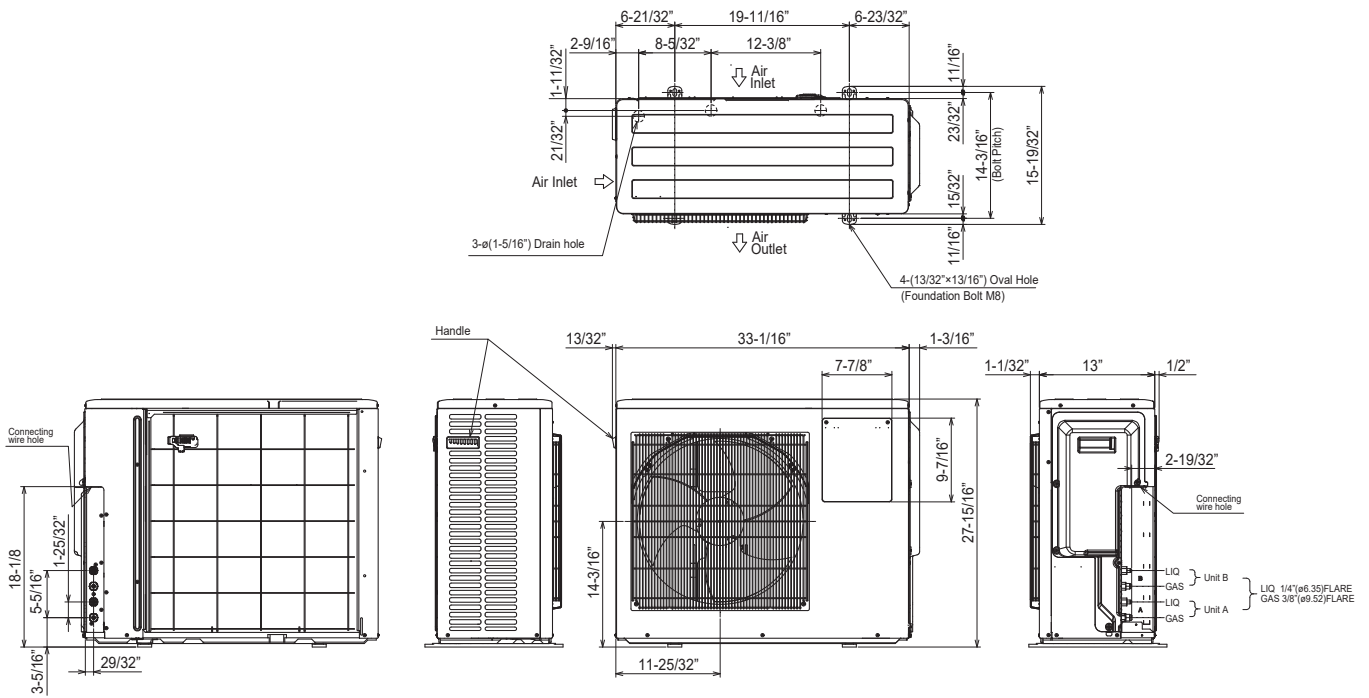

1.FREE SPACE

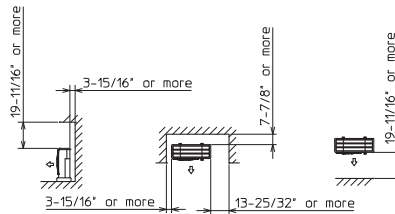

2.SERVICE SPACE

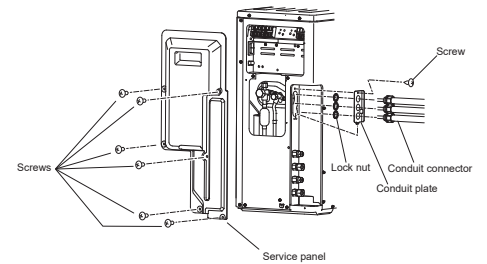
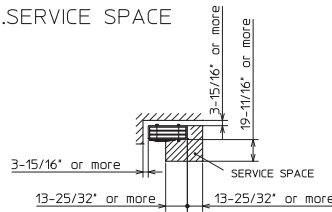

MXZ-3D24NL

Unit: inch (mm)

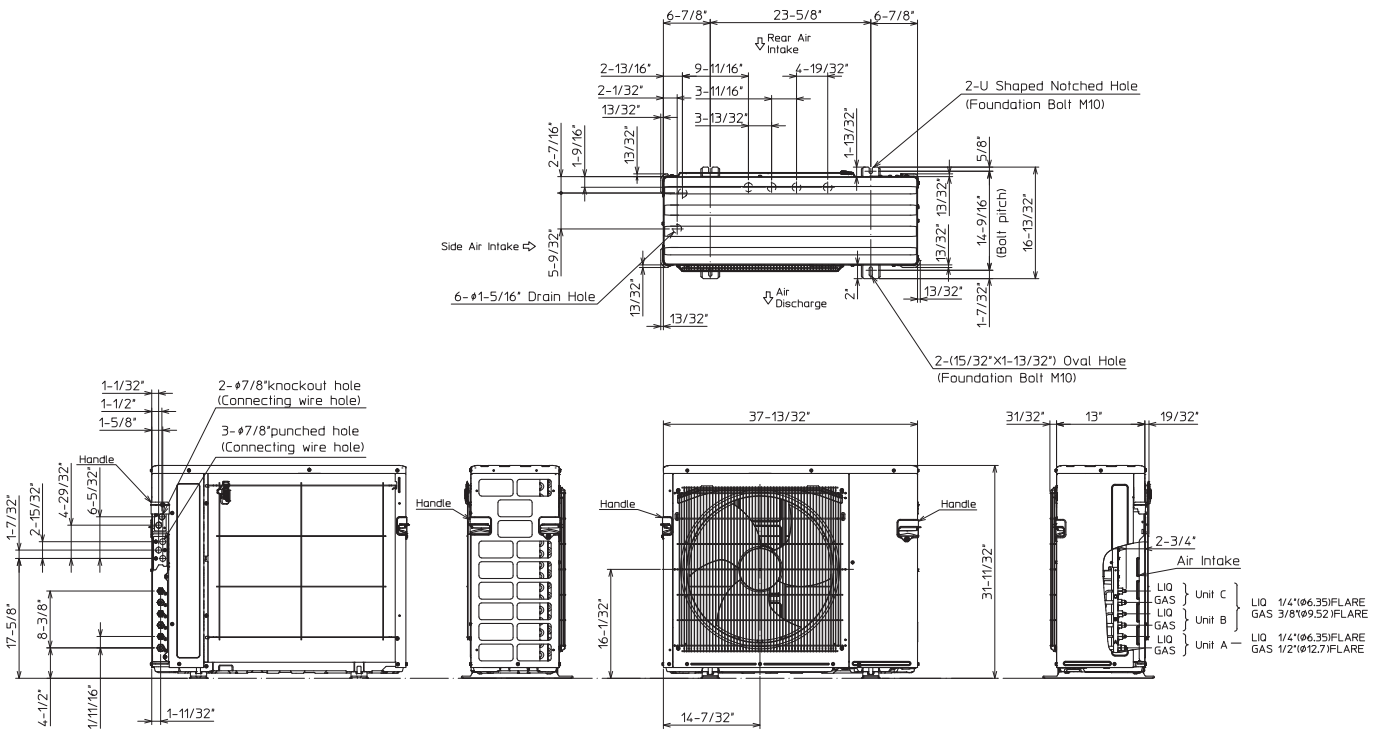

1.FREE SPACE

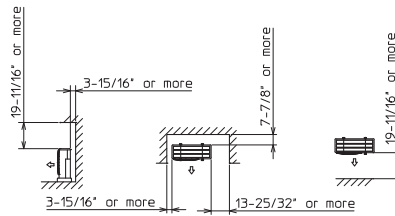

2.SERVICE SPACE

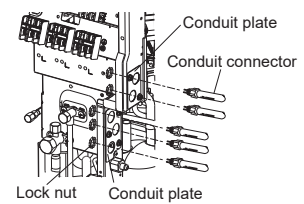
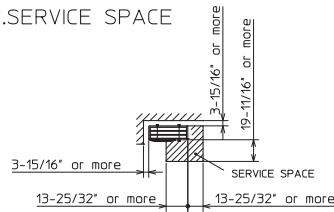

MXZ-4D30NL

Unit: inch (mm)

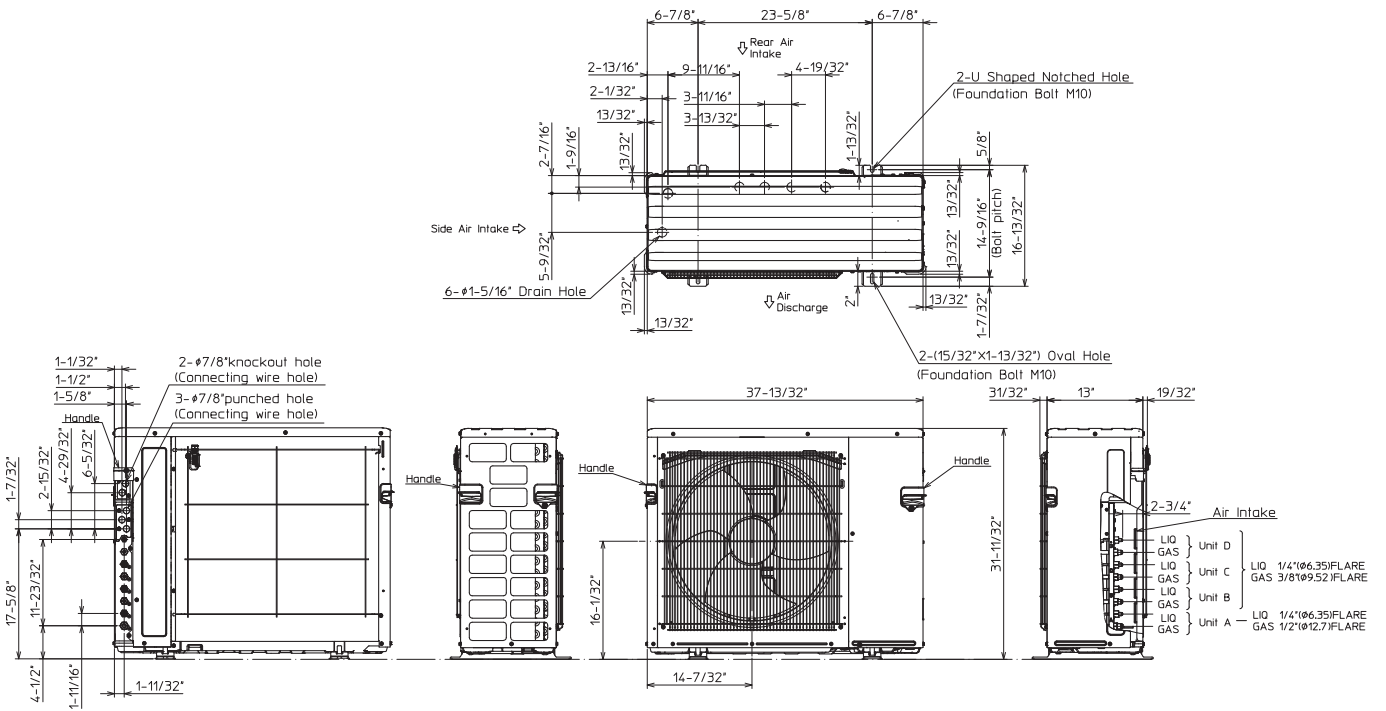

1.FREE SPACE

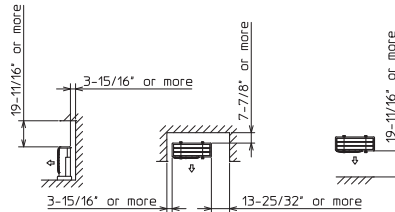

2.SERVICE SPACE

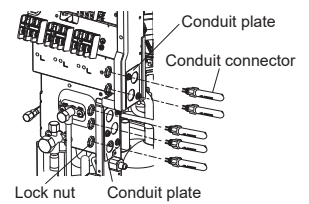
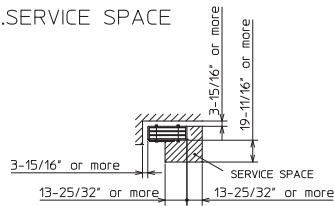

MXZ-5D36NL MXZ-5D42NL

Unit: inch (mm)

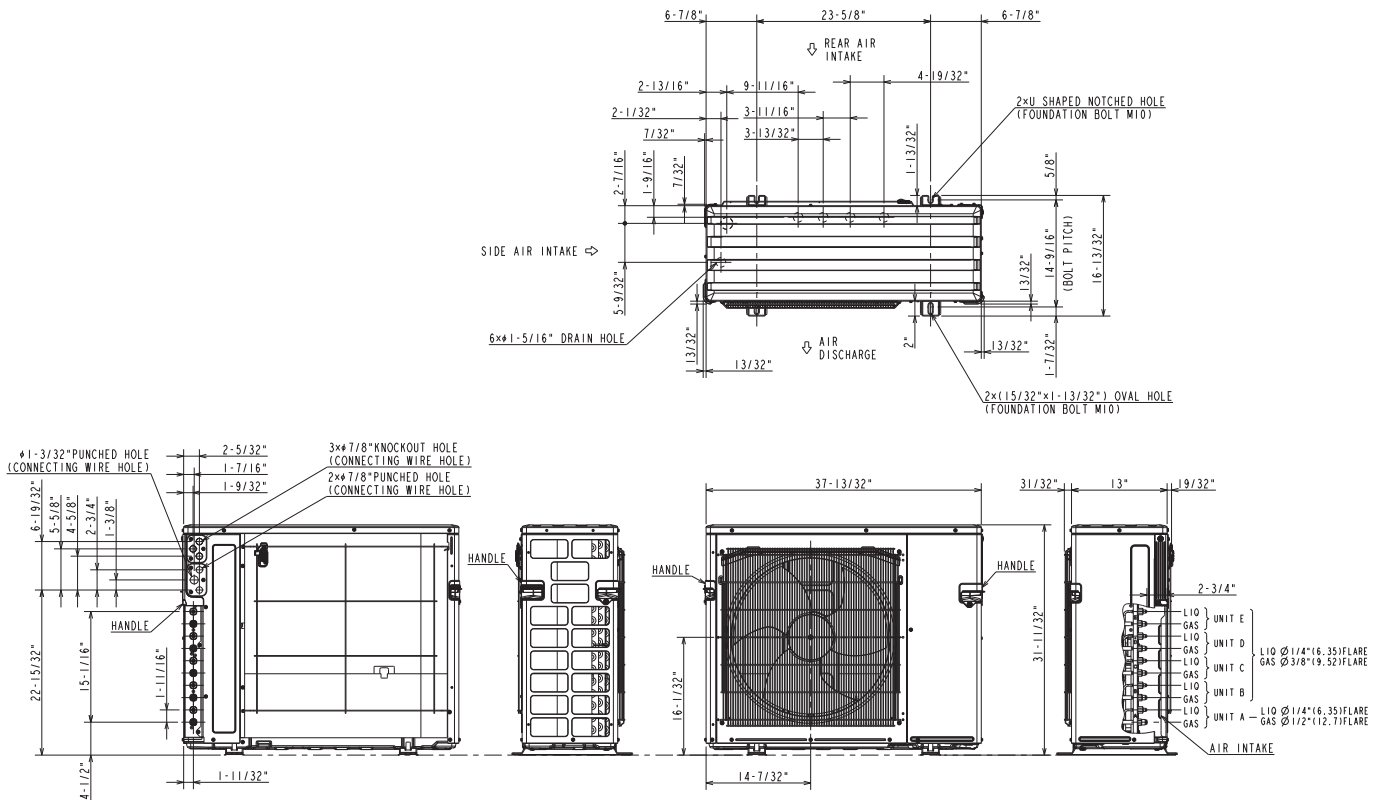

1. FREE SPACE

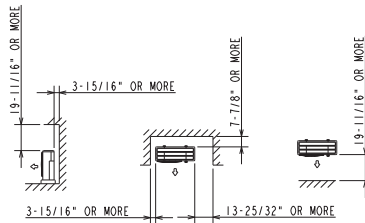

2. SERVICE SPACE

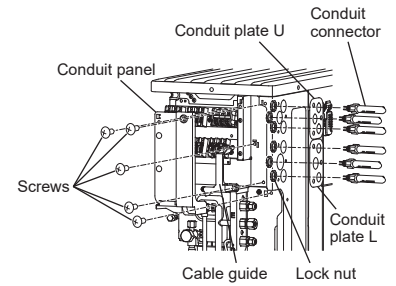
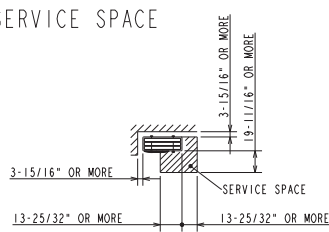

MXZ-2D20NLHZ

Unit: inch (mm)

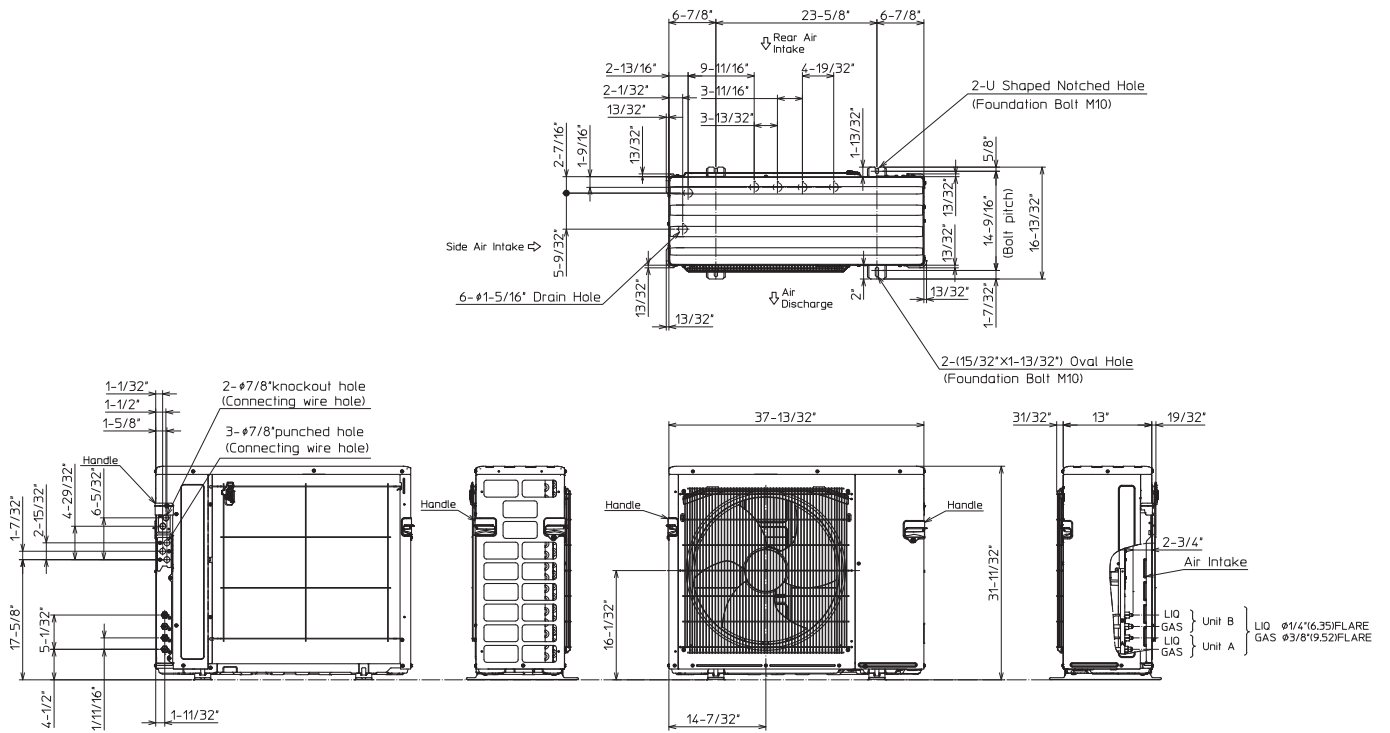

1.FREE SPACE

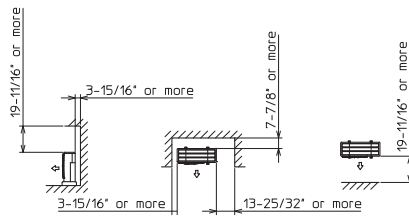

2.SERVICE SPACE

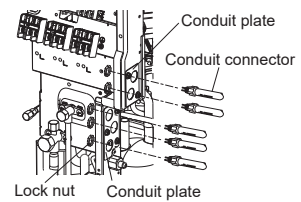
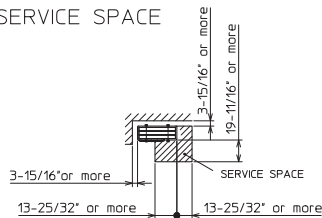

MXZ-3D24NLHZ MXZ-3D30NLHZ

Unit: inch (mm)

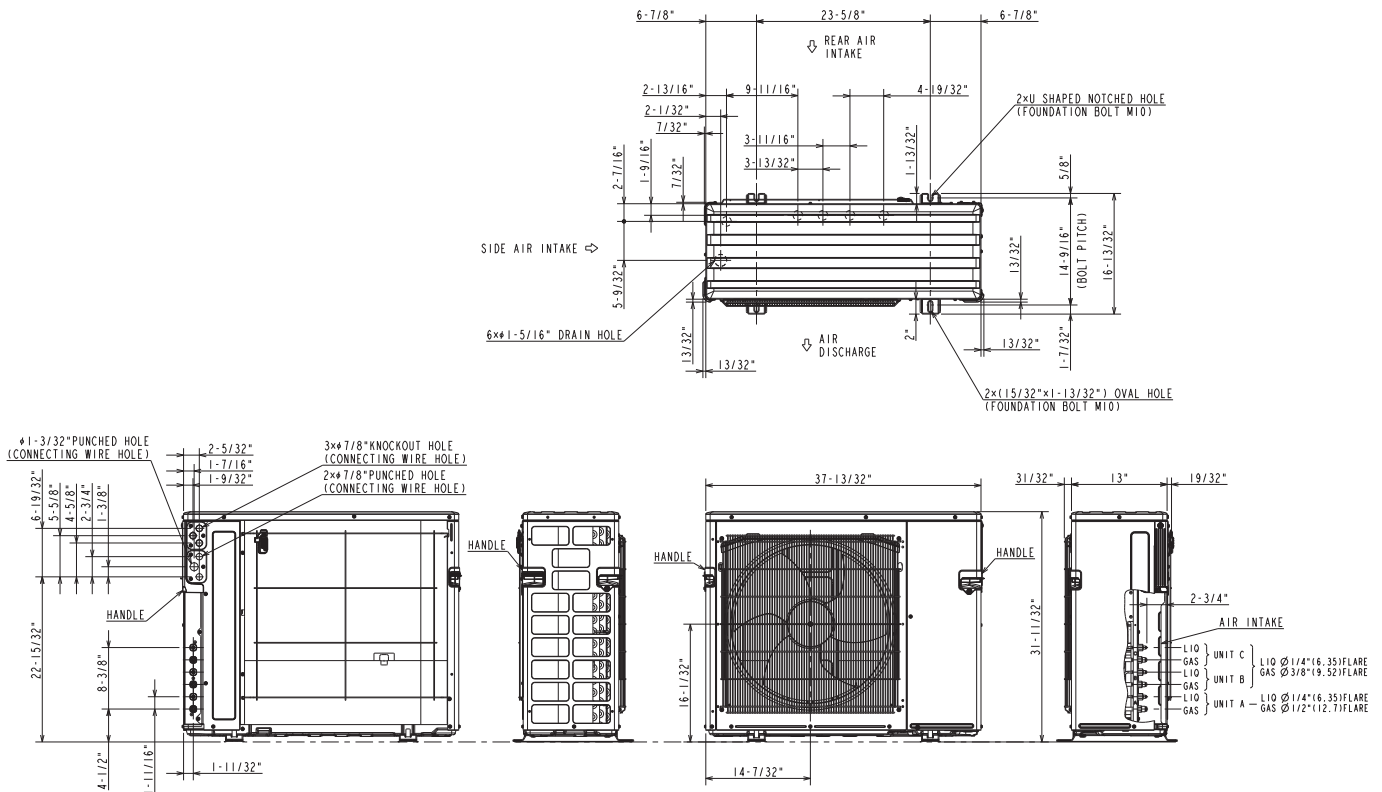

1. FREE SPACE

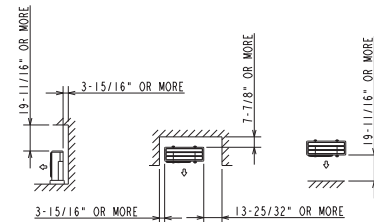

2. SERVICE SPACE

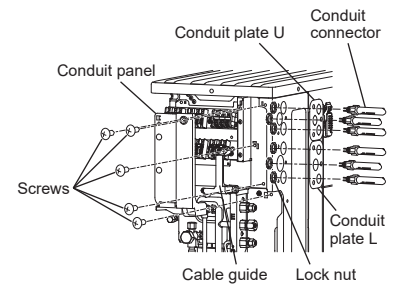
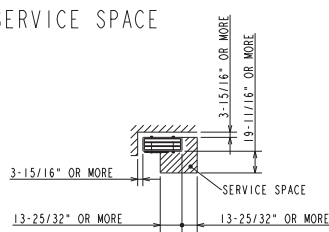

7

WIRING DIAGRAM

MXZ-2D20NL

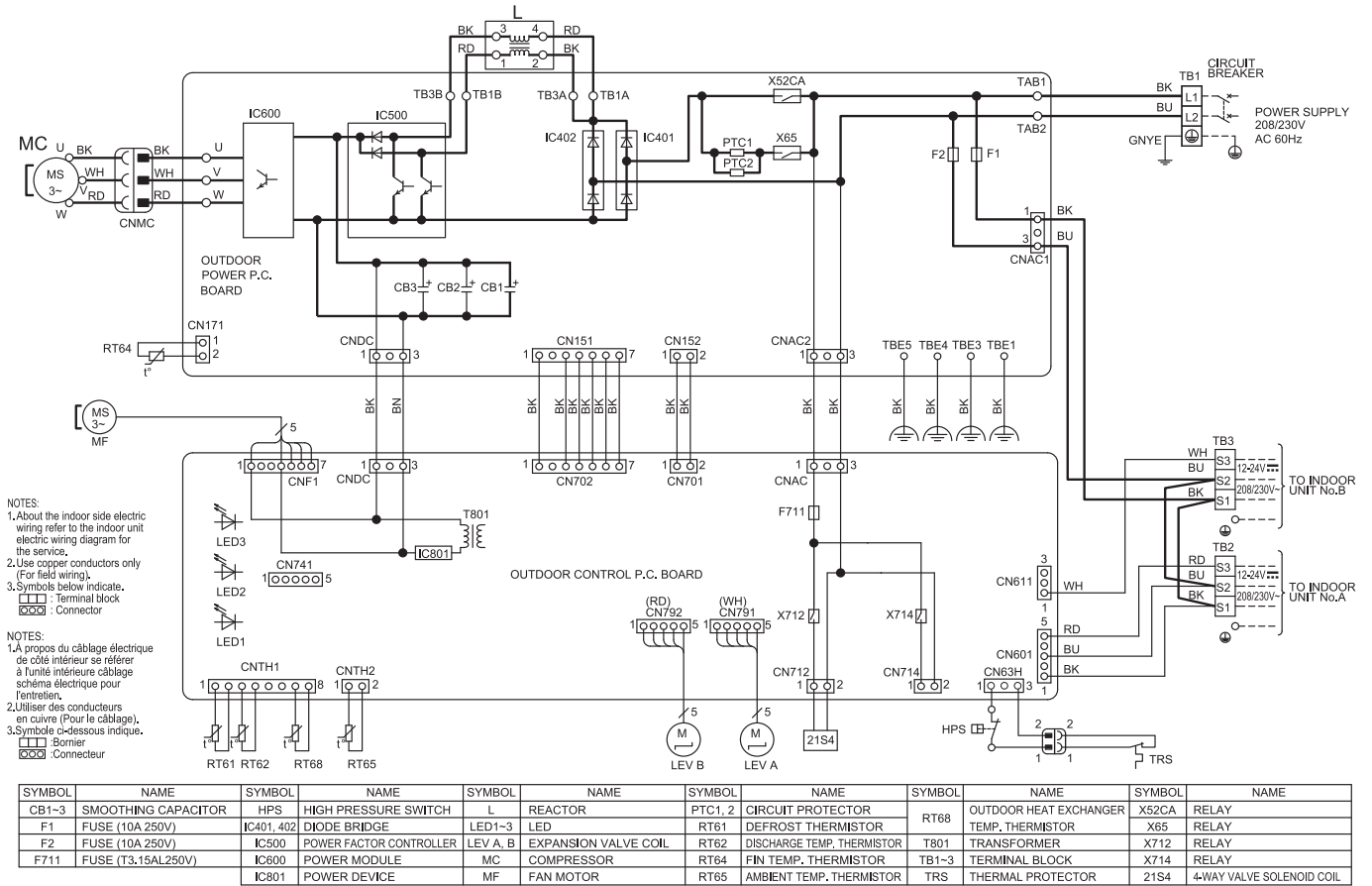

MXZ-3D24NL

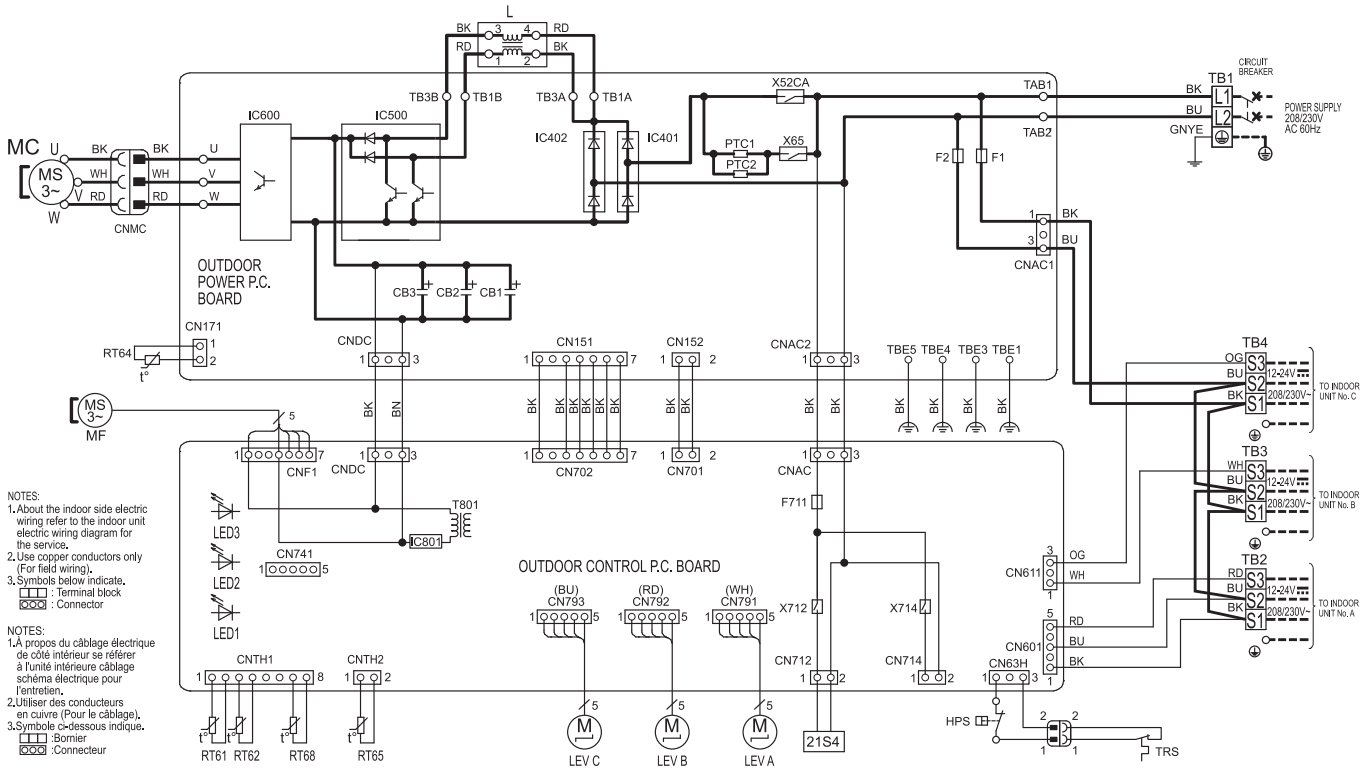

- NOTES:
- About the indoor side electric wiring refer to the indoor unit electric wiring diagram for the service.
 - Use copper conductors only (For field wiring).
 - Symbols below indicate.
 - Terminal block
 - Connector
- NOTES:
- À propos du câblage électrique de côté intérieur se référer à l'unité intérieure câblage schéma électrique pour l'entretien.
 - Utiliser des conducteurs en cuivre (Pour le câblage).
 - Symbole ci-dessous indique.
 - Bornier
 - Connecteur

SYMBOL	NAME	SYMBOL	NAME	SYMBOL	NAME	SYMBOL	NAME	SYMBOL	NAME	SYMBOL	NAME
CB1-3	SMOOTHING CAPACITOR	HPS	HIGH PRESSURE SWITCH	L	REACTOR	PTC1, 2	CIRCUIT PROTECTOR	RT68	OUTDOOR HEAT EXCHANGER	X52CA	RELAY
F1	FUSE (10A 250V)	IC401, 402	DIODE BRIDGE	LED1-3	LED	RT61	DEFROST THERMISTOR	X65	TEMP. THERMISTOR	X65	RELAY
F2	FUSE (10A 250V)	IC500	POWER FACTOR CONTROLLER	LEV A-C	EXPANSION VALVE COIL	RT62	DISCHARGE TEMP. THERMISTOR	T801	TRANSFORMER	X712	RELAY
F711	FUSE (T3.15A 250V)	IC600	POWER MODULE	MC	COMPRESSOR	RT64	FIN TEMP. THERMISTOR	TB1-4	TERMINAL BLOCK	X714	RELAY
		IC801	POWER DEVICE	MF	FAN MOTOR	RT65	AMBIENT TEMP. THERMISTOR	TR5	THERMAL PROTECTOR	21S4	4-WAY VALVE SOLENOID COIL

MXZ-4D30NL

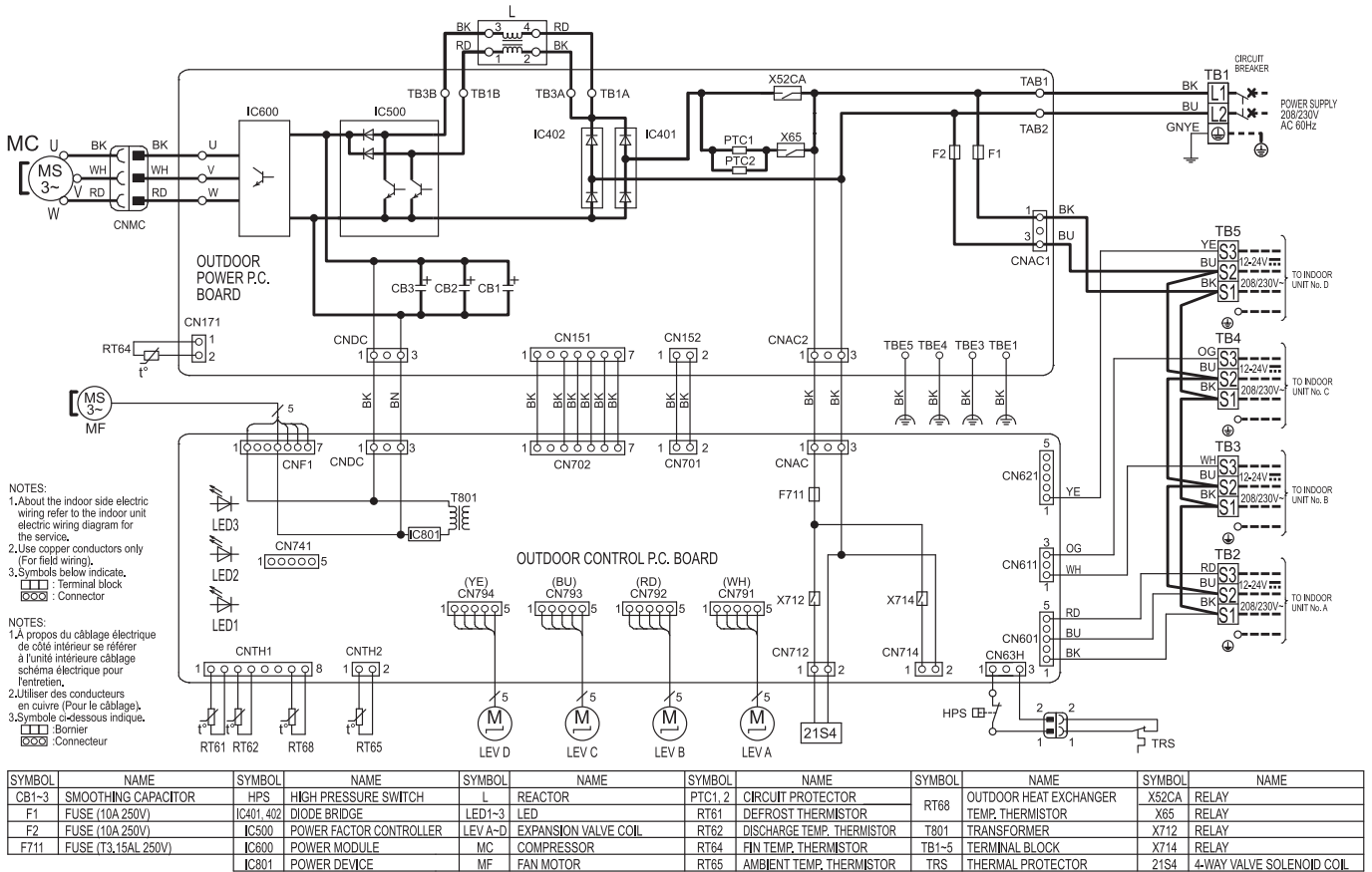

MXZ-5D36NL MXZ-5D42NL

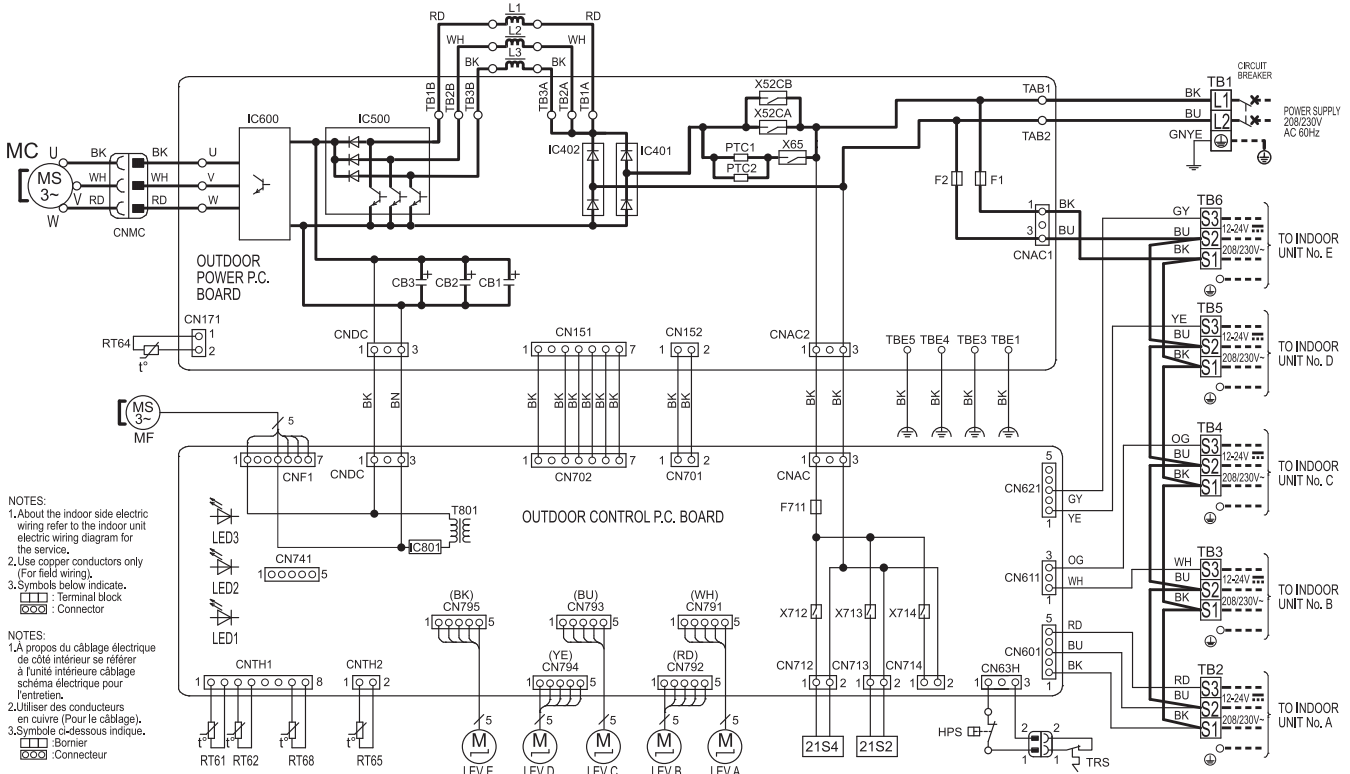

- NOTES:**
- About the indoor side electric wiring refer to the indoor unit electric wiring diagram for the service.
 - Use copper conductors only (For field wiring).
 - Symbols below indicate.
 - Terminal block
 - Connector
- NOTES:**
- À propos du câblage électrique de côté intérieur se référer à l'unité intérieure câblage schéma électrique pour l'entretien.
 - Utiliser des conducteurs en cuivre (Pour le câblage).
 - Symbole ci-dessous indique.
 - Bornier
 - Connecteur

SYMBOL	NAME	SYMBOL	NAME	SYMBOL	NAME	SYMBOL	NAME	SYMBOL	NAME	SYMBOL	NAME
CB1-3	SMOOTHING CAPACITOR	IC500	POWER MODULE	LEV A-E	EXPANSION VALVE COIL	RT62	DISCHARGE TEMP. THERMISTOR	T801	TRANSFORMER	X712-X714	RELAY
F1, F2	FUSE (10A 250V)	IC600	POWER MODULE	MC	COMPRESSOR	RT64	FIN TEMP. THERMISTOR	TB1-6	TERMINAL BLOCK	Z1S2	2-WAY VALVE SOLENOID COIL
F711	FUSE (T3.15AL 250V)	IC801	POWER DEVICE	MF	FAN MOTOR	RT65	AMBIENT TEMP. THERMISTOR	TRS	THERMAL PROTECTOR	Z1S4	4-WAY VALVE SOLENOID COIL
HPS	HIGH PRESSURE SWITCH	L1-3	REACTOR	PTC1, 2	CIRCUIT PROTECTOR	RT68	OUTDOOR HEAT EXCHANGER TEMP. THERMISTOR	X52CA, B	RELAY		
IC401,402	DIODE BRIDGE	LED 1-3	LED	RT61	DEFROST THERMISTOR			X65	RELAY		

MXZ-2D20NLHZ

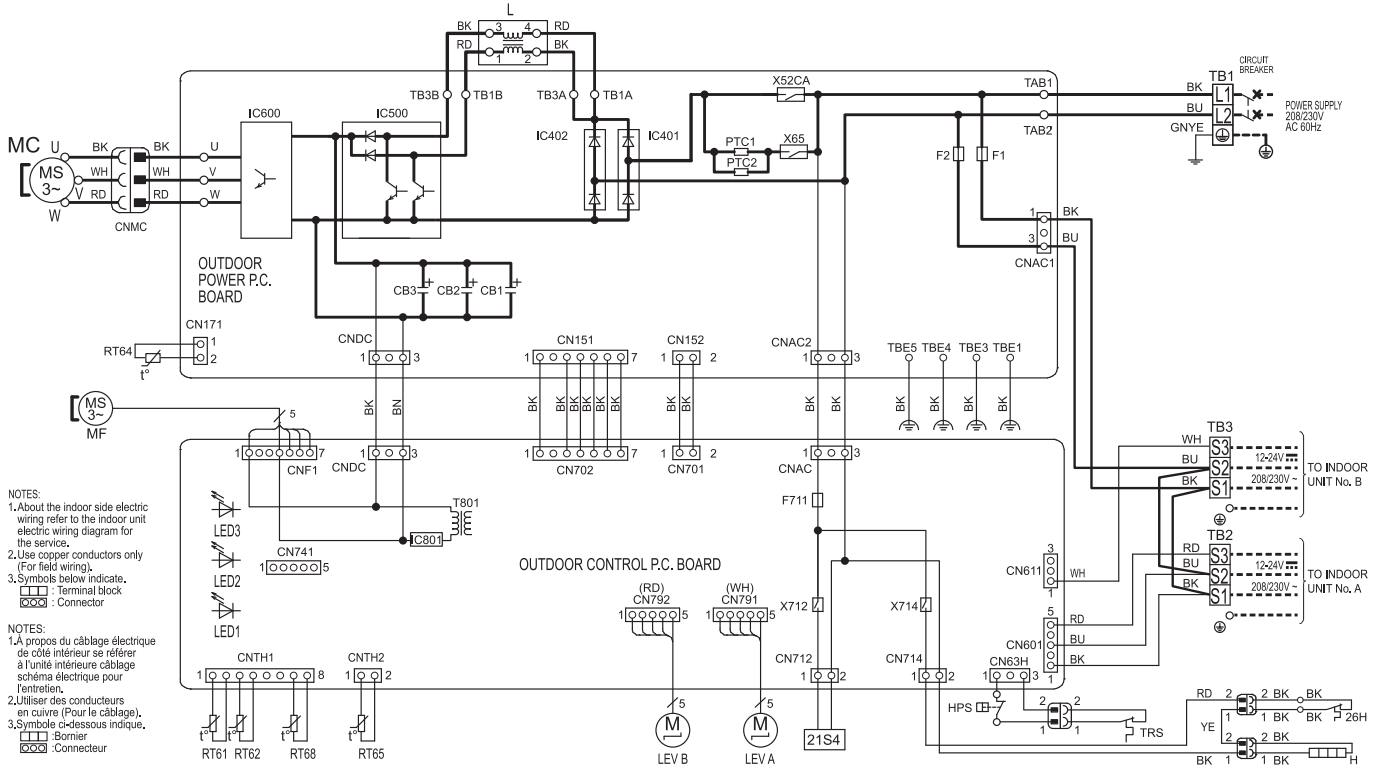

- NOTES:
1. About the indoor side electric wiring refer to the indoor unit electric wiring diagram for the service.
 2. Use copper conductors only (For field wiring).
 3. Symbols below indicate,
 - : Terminal block
 - : Connector

- NOTES:
1. À propos du câblage électrique de côté intérieur se référer à l'unité intérieure câblage schéma électrique pour l'entretien.
 2. Utiliser des conducteurs en cuivre (Pour le câblage).
 3. Symbole ci-dessous indique,
 - : Bornier
 - : Connecteur

SYMBOL	NAME	SYMBOL	NAME	SYMBOL	NAME	SYMBOL	NAME	SYMBOL	NAME	SYMBOL	NAME
CB1-3	SMOOTHING CAPACITOR	HPS	HIGH PRESSURE SWITCH	L	REACTOR	PTC1, 2	CIRCUIT PROTECTOR	RT68	OUTDOOR HEAT EXCHANGER TEMP. THERMISTOR	X52CA	RELAY
F1	FUSE (10A 250V)	IC401, 402	DIODE BRIDGE	LED1-3	LED	RT61	DEFROST THERMISTOR	X65	RELAY		
F2	FUSE (10A 250V)	IC500	POWER FACTOR CONTROLLER	LEV A, B	EXPANSION VALVE COIL	RT62	DISCHARGE TEMP. THERMISTOR	TB01	TRANSFORMER	X712, X714	RELAY
F711	FUSE (T3,15AL 250V)	IC600	POWER MODULE	MC	COMPRESSOR	RT64	FIN TEMP. THERMISTOR	TB1-3	TERMINAL BLOCK	21S4	4-WAY VALVE SOLENOID COIL
H	DEFROST HEATER	IC801	POWER DEVICE	MF	FAN MOTOR	RT65	AMBIENT TEMP. THERMISTOR	TRS	THERMAL PROTECTOR	26H	HEATER PROTECTOR

MXZ-3D24NLHZ MXZ-3D30NLHZ

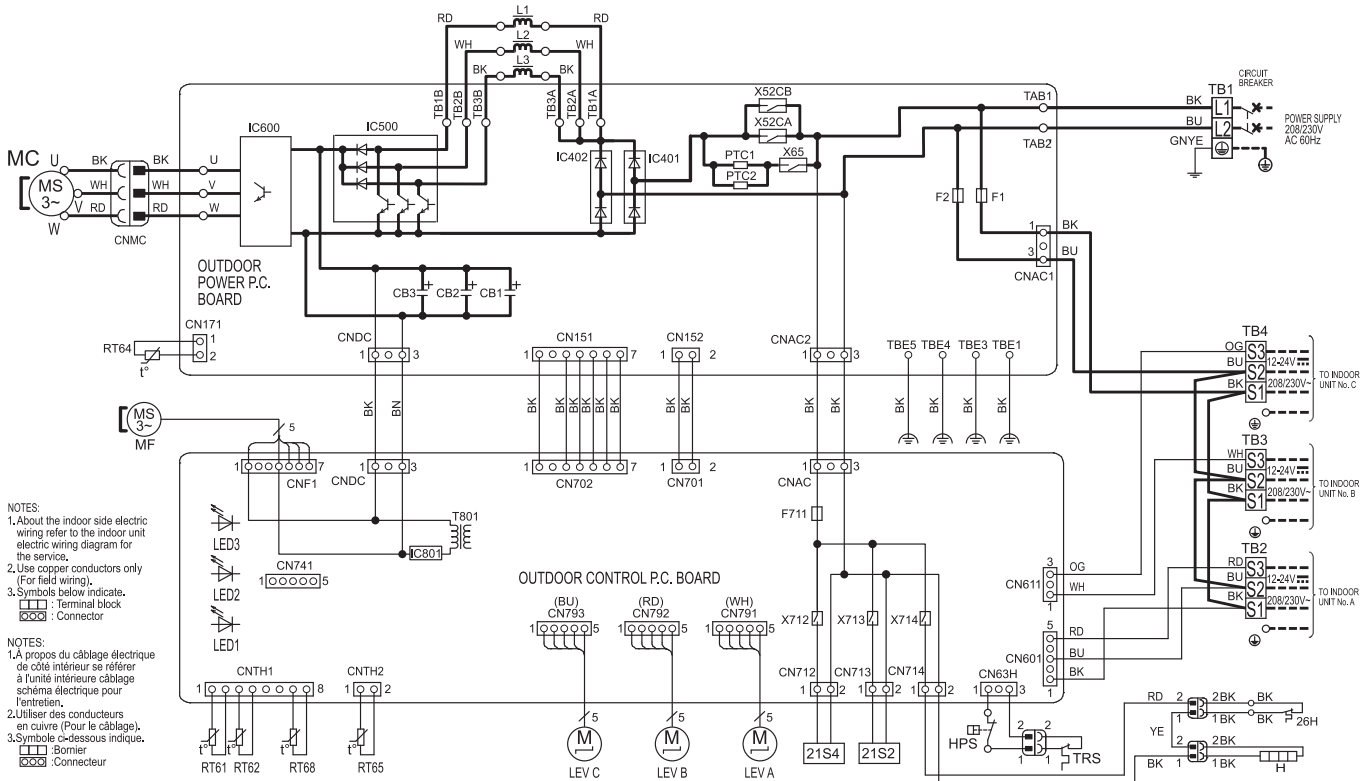

- NOTES:**
 1. About the indoor side electric wiring refer to the indoor unit electric wiring diagram for the service.
 2. Use copper conductors only (For field wiring).
 3. Symbols below indicate.
 □ : Terminal block
 ○ : Connector
- NOTES:**
 1. À propos du câblage électrique de côté intérieur se référer à l'unité intérieure câblage schéma électrique pour l'entretien.
 2. Utiliser des conducteurs en cuivre (Pour le câblage).
 3. Symbole ci-dessous indique.
 □ : Bornier
 ○ : Connecteur

SYMBOL	NAME	SYMBOL	NAME	SYMBOL	NAME	SYMBOL	NAME	SYMBOL	NAME	SYMBOL	NAME
CB1-3	SMOOTHING CAPACITOR	IC401, 402	DIODE BRIDGE	LED1-3	LED	RT61	DEFROST THERMISTOR	T801	TRANSFORMER	X65	RELAY
F1, F2	FUSE (10A 250V)	IC500	POWER FACTOR CONTROLLER	LEV A-C	EXPANSION VALVE COIL	RT62	DISCHARGE TEMP. THERMISTOR	TB1-4	TERMINAL BLOCK	X712-X714	RELAY
F711	FUSE (T3,15AL 250V)	IC600	POWER MODULE	MC	COMPRESSOR	RT64	FIN TEMP. THERMISTOR	TRS	THERMAL PROTECTOR	21S2	2-WAY VALVE SOLENOID COIL
HPS	HIGH PRESSURE SWITCH	IC801	POWER DEVICE	MF	FAN MOTOR	RT65	AMBIENT TEMP. THERMISTOR	X52CA, B	RELAY	21S4	4-WAY VALVE SOLENOID COIL
H	DEFROST HEATER	L1-3	REACTOR	PTC1, 2	CIRCUIT PROTECTOR	RT68	OUTDOOR HEAT EXCHANGER TEMP. THERMISTOR			26H	HEATER PROTECTOR

MXZ-2D20NL

Unit: inch (mm)

R.V.coil
 OFF → Refrigerant flow in cooling
 ON - - - - - Refrigerant flow in heating

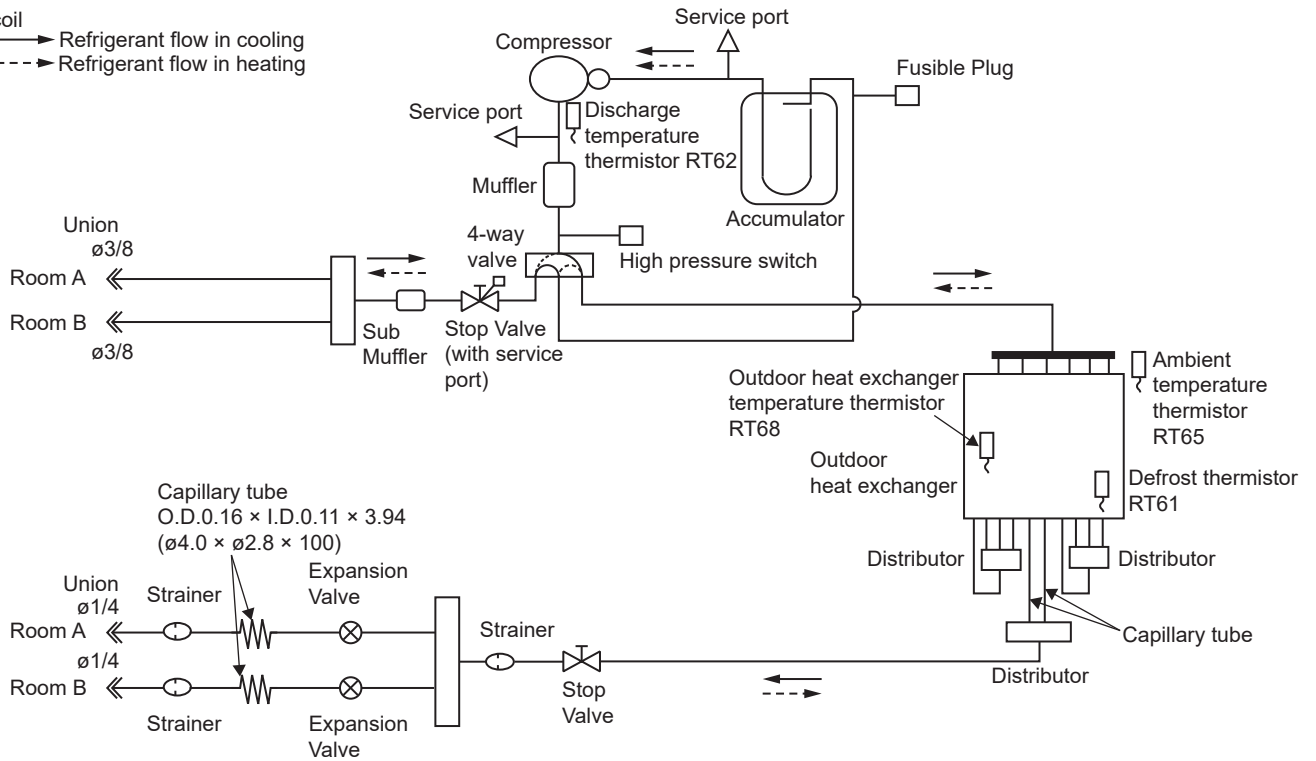

MXZ-2D20NL

Operating Range

		Indoor air intake temperature	Outdoor air intake temperature
Cooling	Maximum	95°FDB, 71°FWB	115°FDB
	Minimum	67°FDB, 57°FWB	14°FDB
Heating	Maximum	80°FDB, 67°FWB	75°FDB
	Minimum	70°FDB, 60°FWB	5°FWB

MAX. REFRIGERANT PIPING LENGTH & PIPE SIZE SELECTION

Piping length each indoor unit (a, b)	82 ft.
Total piping length (a+b)	164 ft.
Number of bends for each unit	25
Total number of bends	50

*It is irrelevant which unit is higher.

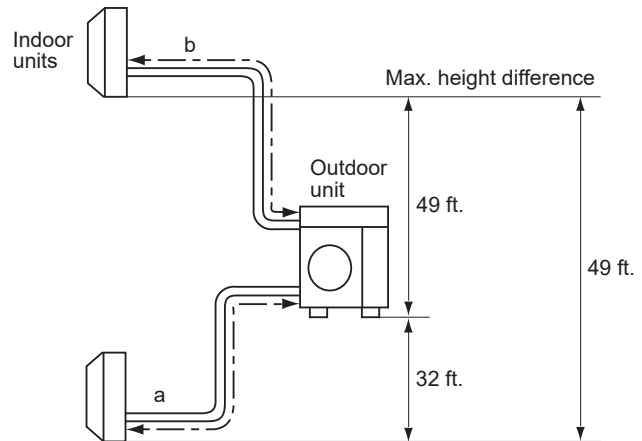

- Refrigerant pipe diameter is different according to indoor unit to be connected. When using extension pipes, refer to the tables below.
- When the diameter of refrigerant pipe is different from that of outdoor unit union, use optional pipe adapter. For further information on pipe adapters, refer to "DIFFERENT-DIAMETER PIPE in PARTS CATALOG".

Unit: inch

Outdoor unit union diameter		
For		
Indoor unit A	Liquid	1/4
	Gas	3/8
Indoor unit B	Liquid	1/4
	Gas	3/8

MXZ-3D24NL

Unit: inch (mm)

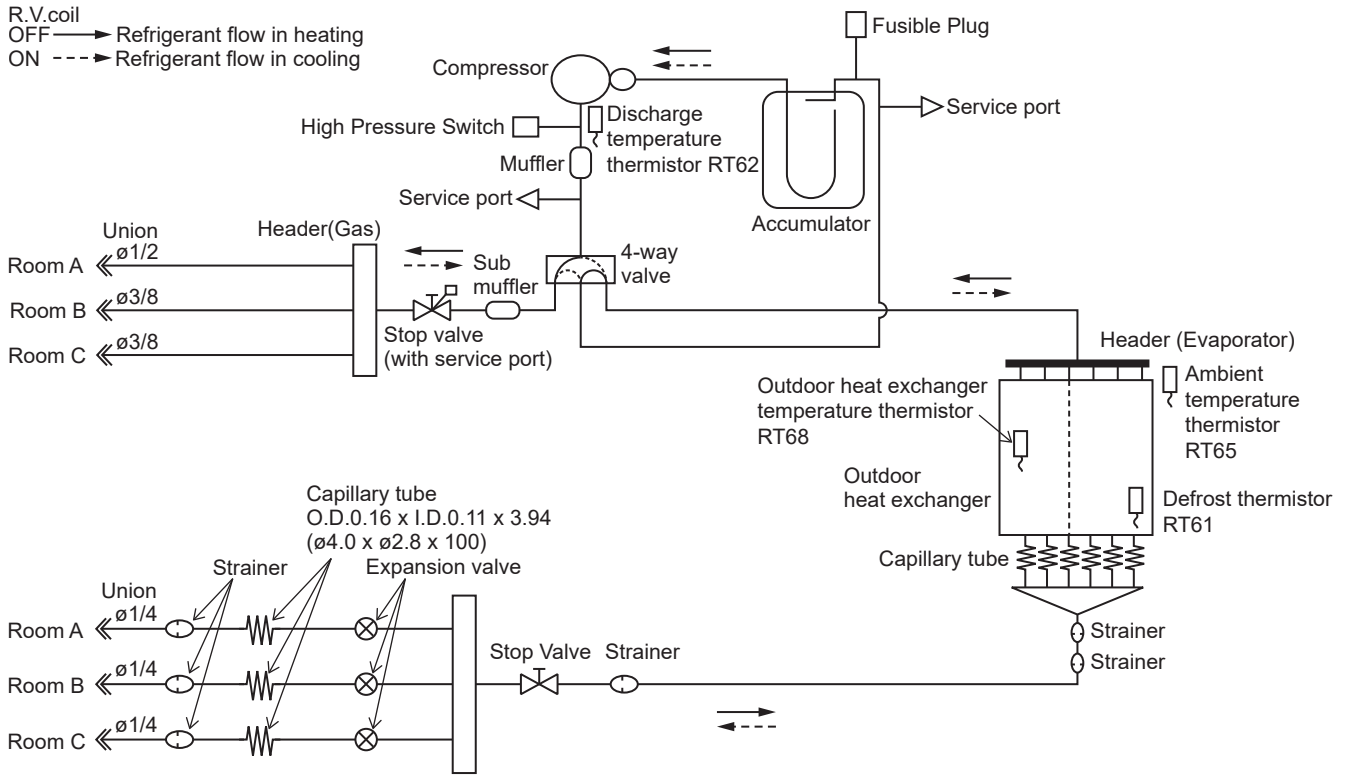

MXZ-3D24NL

Operating Range

		Indoor air intake temperature	Outdoor air intake temperature
Cooling	Maximum	95°FDB, 71°FWB	115°FDB
	Minimum	67°FDB, 57°FWB	14°FDB
Heating	Maximum	80°FDB, 67°FWB	75°FDB, 65°FWB
	Minimum	70°FDB, 60°FWB	6°FDB, 5°FWB

MAX. REFRIGERANT PIPING LENGTH & PIPE SIZE SELECTION

Piping length each indoor unit (a, b, c)	82 ft.
Total piping length (a+b+c)	230 ft.
Number of bends for each unit	25
Total number of bends	70

*It is irrelevant which unit is higher.

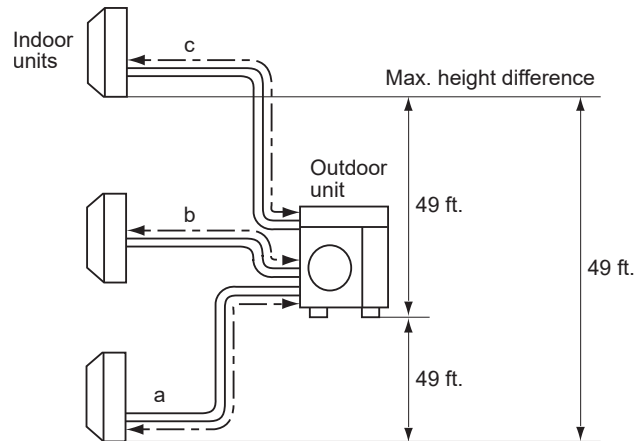

- Refrigerant pipe diameter is different according to indoor unit to be connected. When using extension pipes, refer to the tables below.
- When the diameter of refrigerant pipe is different from that of outdoor unit union, use optional pipe adapter. For further information on pipe adapters, refer to "DIFFERENT-DIAMETER PIPE in PARTS CATALOG".

Unit: inch

Outdoor unit union diameter		
For		
Indoor unit A	Liquid	1/4
	Gas	1/2
Indoor unit B	Liquid	1/4
	Gas	3/8
Indoor unit C	Liquid	1/4
	Gas	3/8

MXZ-4D30NL

Unit: inch (mm)

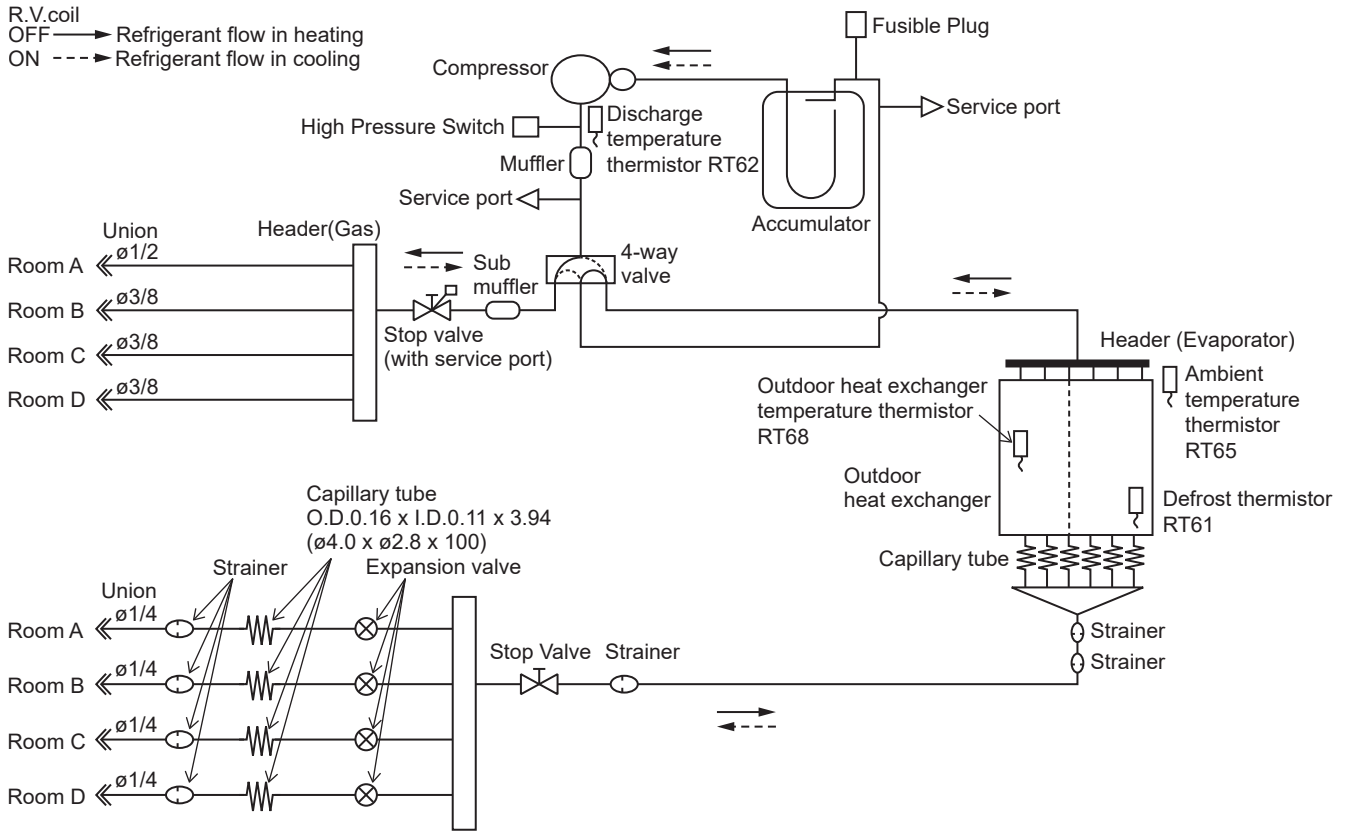

MXZ-4D30NL

Operating Range

		Indoor air intake temperature	Outdoor air intake temperature
Cooling	Maximum	95°FDB, 71°FWB	115°FDB
	Minimum	67°FDB, 57°FWB	14°FDB
Heating	Maximum	80°FDB, 67°FWB	75°FDB, 65°FWB
	Minimum	70°FDB, 60°FWB	6°FDB, 5°FWB

MAX. REFRIGERANT PIPING LENGTH & PIPE SIZE SELECTION

Piping length each indoor unit (a, b, c, d)	82 ft.
Total piping length (a+b+c+d)	230 ft.
Number of bends for each unit	25
Total number of bends	70

*It is irrelevant which unit is higher.

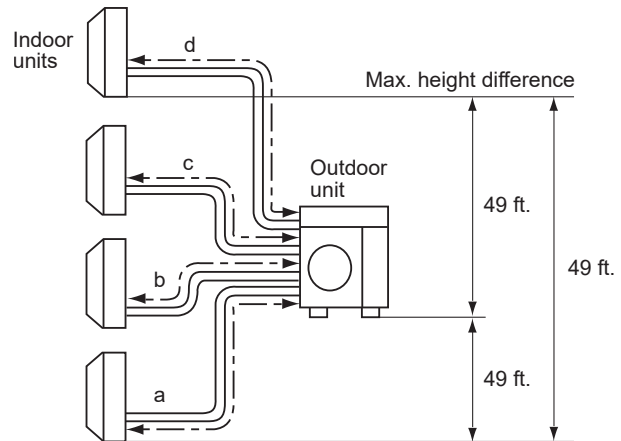

- Refrigerant pipe diameter is different according to indoor unit to be connected. When using extension pipes, refer to the tables below.
- When the diameter of refrigerant pipe is different from that of outdoor unit union, use optional pipe adapter. For further information on pipe adapters, refer to "DIFFERENT-DIAMETER PIPE in PARTS CATALOG".

Unit: inch

Outdoor unit union diameter		
For		
Indoor unit A	Liquid	1/4
	Gas	1/2
Indoor unit B	Liquid	1/4
	Gas	3/8
Indoor unit C	Liquid	1/4
	Gas	3/8
Indoor unit D	Liquid	1/4
	Gas	3/8

MXZ-5D36NL MXZ-5D42NL

Unit: inch (mm)

R.V.coil

OFF → Refrigerant flow in heating
 ON - - - → Refrigerant flow in cooling

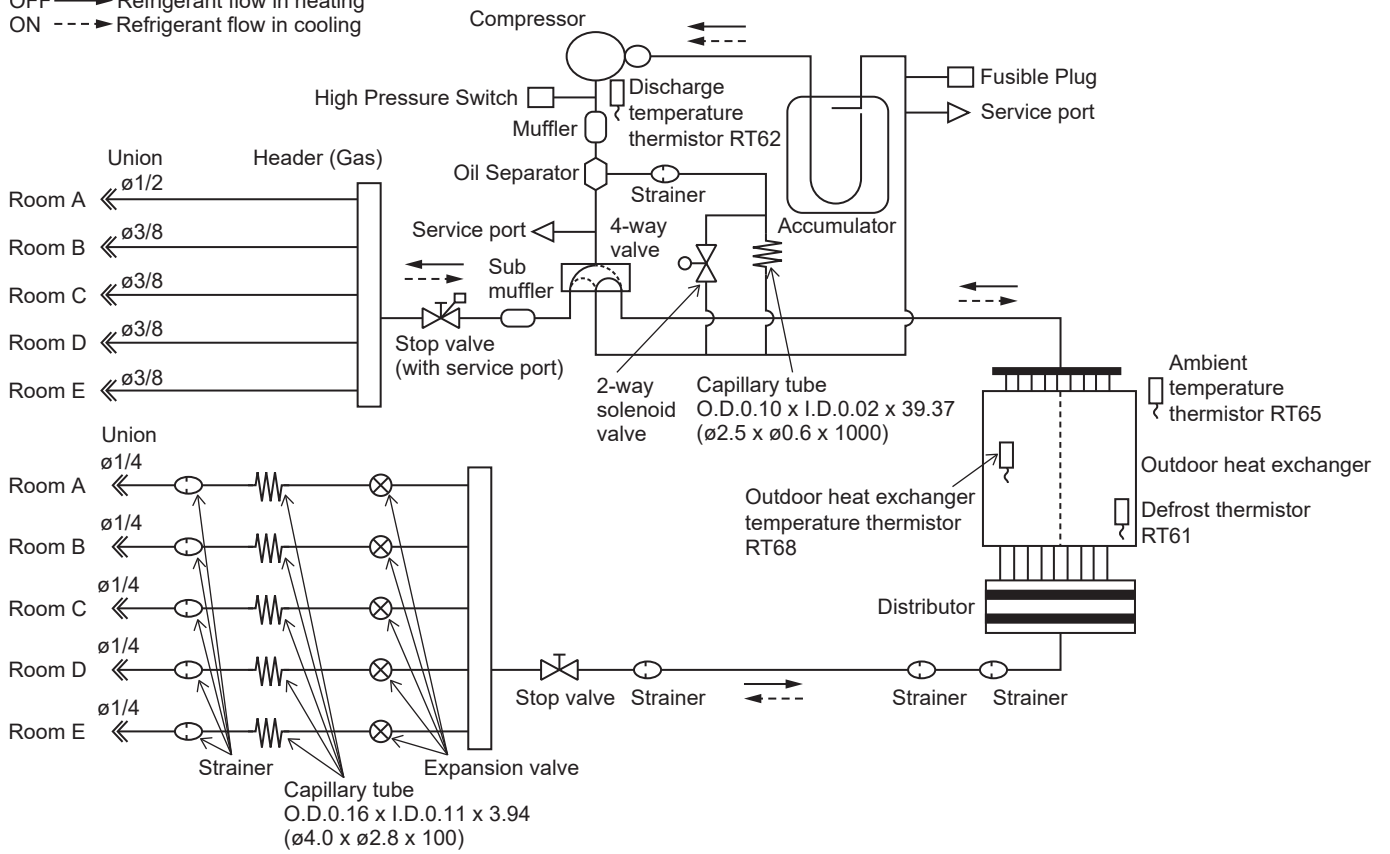

MXZ-5D36NL MXZ-5D42NL

Operating Range

		Indoor air intake temperature	Outdoor air intake temperature
Cooling	Maximum	95°FDB, 71°FWB	115°FDB
	Minimum	67°FDB, 57°FWB	14°FDB
Heating	Maximum	80°FDB, 67°FWB	75°FDB, 65°FWB
	Minimum	70°FDB, 60°FWB	6°FDB, 5°FWB

MAX. REFRIGERANT PIPING LENGTH & PIPE SIZE SELECTION

MXZ-5D36NL

Piping length each indoor unit (a, b, c, d, e)	82 ft.
Total piping length (a+b+c+d+e)	230 ft.
Number of bends for each unit	25
Total number of bends	70

MXZ-5D42NL

Piping length each indoor unit (a, b, c, d, e)	82 ft.
Total piping length (a+b+c+d+e)	262 ft.
Number of bends for each unit	25
Total number of bends	80

*It is irrelevant which unit is higher.

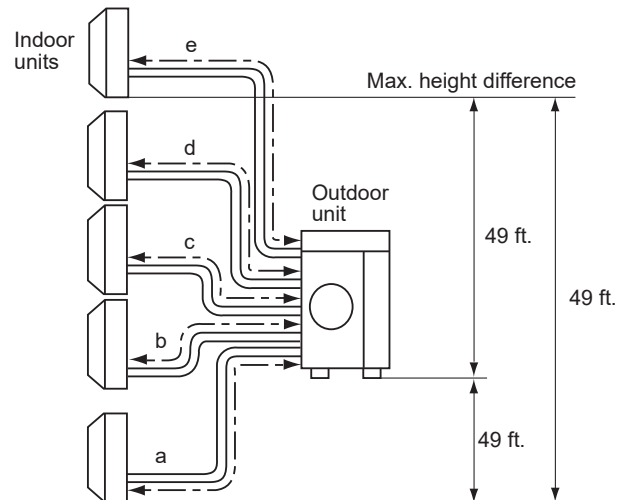

- Refrigerant pipe diameter is different according to indoor unit to be connected. When using extension pipes, refer to the tables below.
- When the diameter of refrigerant pipe is different from that of outdoor unit union, use optional pipe adapter. For further information on pipe adapters, refer to "DIFFERENT-DIAMETER PIPE in PARTS CATALOG".

Unit: inch

Outdoor unit union diameter		
For		
Indoor unit A	Liquid	1/4
	Gas	1/2
Indoor unit B	Liquid	1/4
	Gas	3/8
Indoor unit C	Liquid	1/4
	Gas	3/8
Indoor unit D	Liquid	1/4
	Gas	3/8
Indoor unit E	Liquid	1/4
	Gas	3/8

MXZ-2D20NLHZ

Unit: inch (mm)

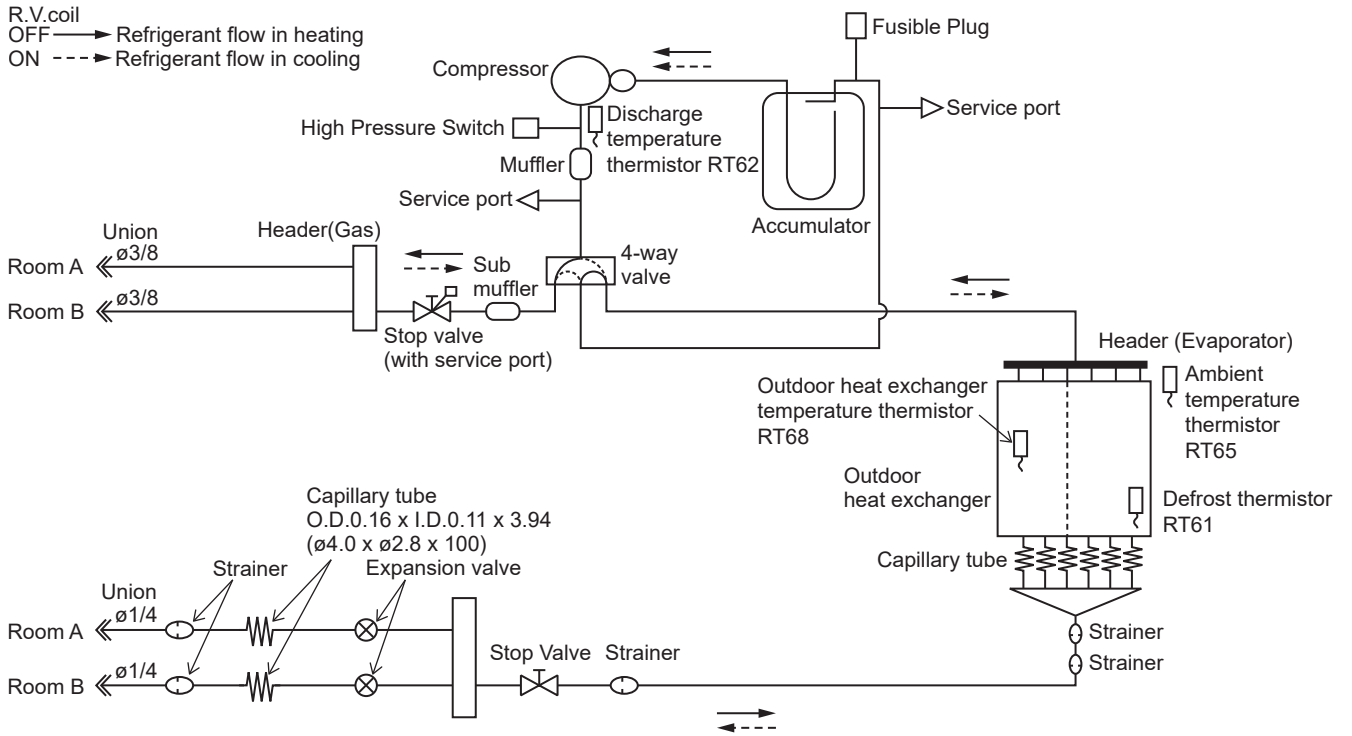

MXZ-2D20NLHZ

Operating Range

		Indoor air intake temperature	Outdoor air intake temperature
Cooling	Maximum	95°FDB, 71°FWB	115°FDB
	Minimum	67°FDB, 57°FWB	14°FDB
Heating	Maximum	80°FDB, 67°FWB	75°FDB, 65°FWB
	Minimum	70°FDB, 60°FWB	-12°FDB, -13°FWB

MAX. REFRIGERANT PIPING LENGTH & PIPE SIZE SELECTION

Piping length each indoor unit (a, b)	82 ft.
Total piping length (a+b)	164 ft.
Number of bends for each unit	25
Total number of bends	50

*It is irrelevant which unit is higher.

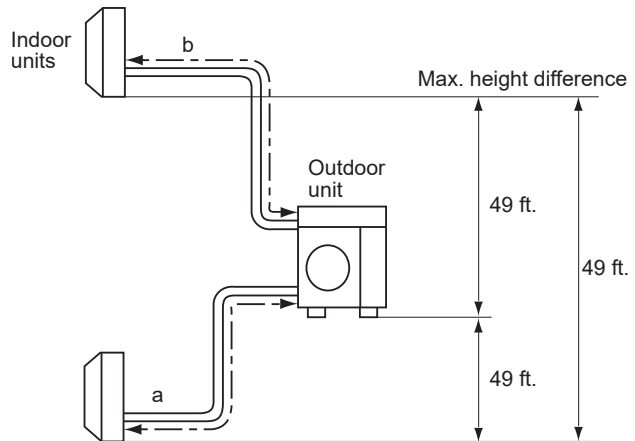

- Refrigerant pipe diameter is different according to indoor unit to be connected. When using extension pipes, refer to the tables below.
- When the diameter of refrigerant pipe is different from that of outdoor unit union, use optional pipe adapter. For further information on pipe adapters, refer to "DIFFERENT-DIAMETER PIPE in PARTS CATALOG".

Unit: inch

Outdoor unit union diameter		
For		
Indoor unit A	Liquid	1/4
	Gas	3/8
Indoor unit B	Liquid	1/4
	Gas	3/8

MXZ-3D24NLHZ MXZ-3D30NLHZ

R.V.coil

OFF → Refrigerant flow in heating

ON - - - → Refrigerant flow in cooling

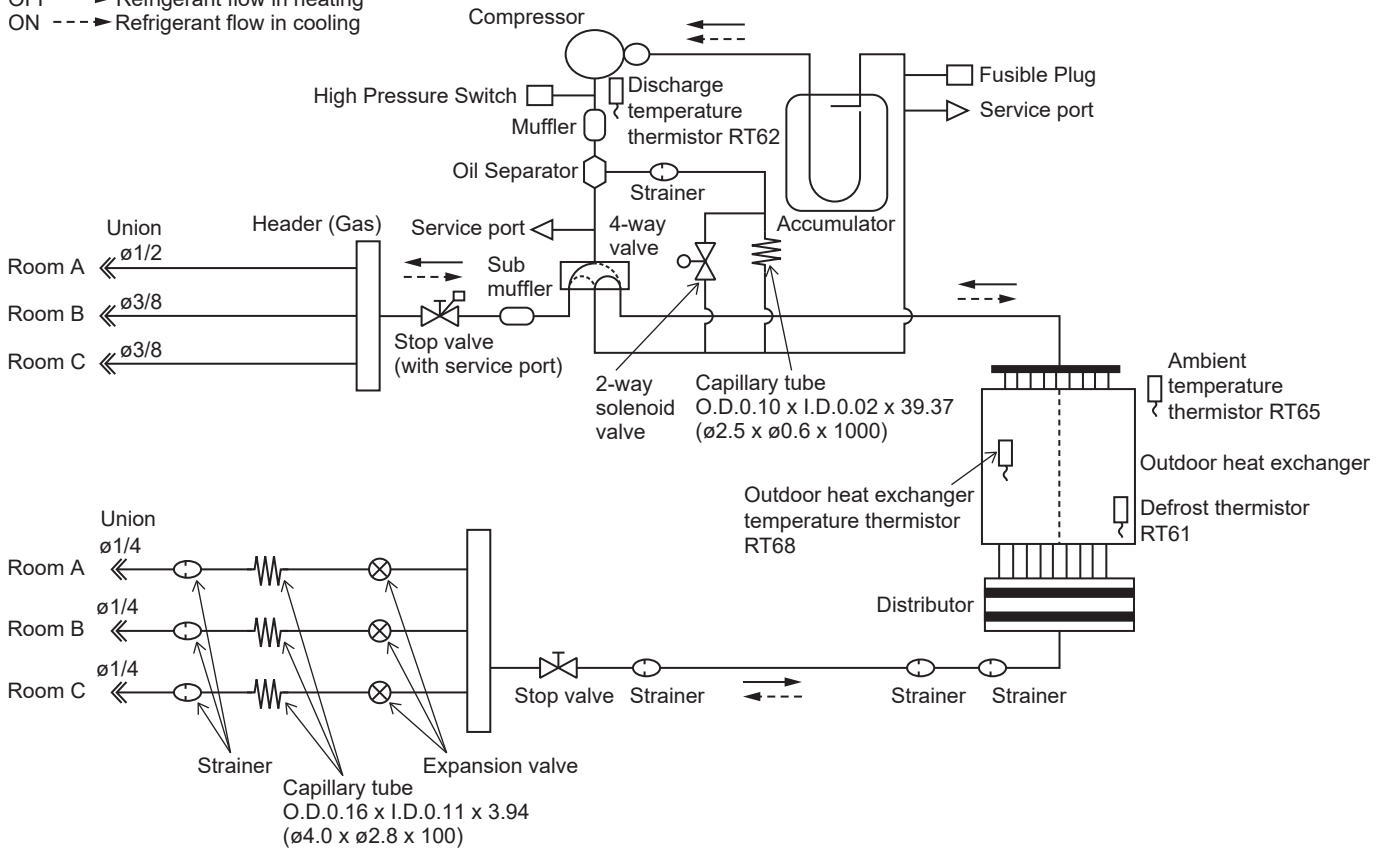

MXZ-3D24NLHZ MXZ-3D30NLHZ

Operating Range

		Indoor air intake temperature	Outdoor air intake temperature
Cooling	Maximum	95°FDB, 71°FWB	115°FDB
	Minimum	67°FDB, 57°FWB	14°FDB
Heating	Maximum	80°FDB, 67°FWB	75°FDB, 65°FWB
	Minimum	70°FDB, 60°FWB	-12°FDB, -13°FWB

MAX. REFRIGERANT PIPING LENGTH & PIPE SIZE SELECTION

Piping length each indoor unit (a, b, c)	82 ft.
Total piping length (a+b+c)	230 ft.
Number of bends for each unit	25
Total number of bends	70

*It is irrelevant which unit is higher.

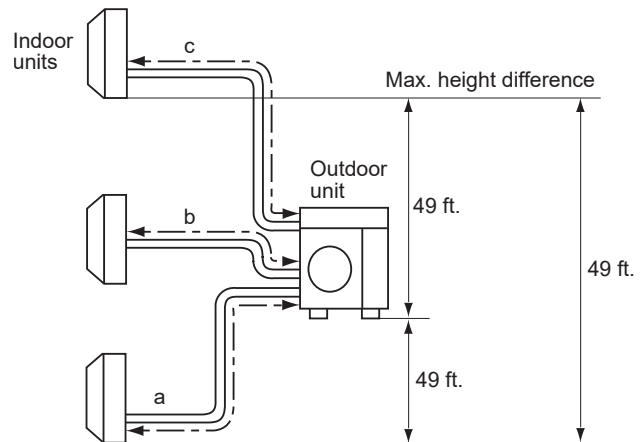

- Refrigerant pipe diameter is different according to indoor unit to be connected. When using extension pipes, refer to the tables below.
- When the diameter of refrigerant pipe is different from that of outdoor unit union, use optional pipe adapter. For further information on pipe adapters, refer to "DIFFERENT-DIAMETER PIPE in PARTS CATALOG".

Unit: inch

Outdoor unit union diameter		
For		
Indoor unit A	Liquid	1/4
	Gas	1/2
Indoor unit B	Liquid	1/4
	Gas	3/8
Indoor unit C	Liquid	1/4
	Gas	3/8

PUMPING DOWN

When relocating or disposing of the air conditioner, pump down the system following the procedure below so that no refrigerant is released into the atmosphere.

- (1) Turn off the breaker.
- (2) Connect the gauge manifold valve to the service port of the stop valve on the gas pipe side of the outdoor unit.
- (3) Fully close the stop valve on the liquid pipe side of the outdoor unit.
- (4) Turn on the breaker.
- (5) Start the emergency COOL operation on all the indoor units.
- (6) When the pressure gauge shows 0.1 to 0 psi [Gauge] (0.05 to 0 MPa), fully close the stop valve on the gas pipe side of the outdoor unit and stop the operation. (Refer to the indoor unit installation manual about the method for stopping the operation.)
 - * If too much refrigerant has been added to the air conditioner system, the pressure may not drop to 0.1 to 0 psi [Gauge] (0.05 to 0 MPa), or the protection function may operate due to the pressure increase in the high-pressure refrigerant circuit. If this occurs, use a refrigerant collecting device to collect all of the refrigerant in the system, and then recharge the system with the correct amount of refrigerant after the indoor and outdoor units have been relocated.
- (7) Turn off the breaker. Remove the pressure gauge and the refrigerant piping.

⚠ WARNING

When the refrigerant circuit has a leak, do not execute pump down with the compressor.
When pumping down the refrigerant, stop the compressor before disconnecting the refrigerant pipes.
If the refrigerant pipes are disconnected while the compressor is running and the stop valve is open, air could be drawn in and the pressure in the refrigeration cycle could become abnormally high.
The compressor may burst and cause injury if any foreign substance, such as air, enters the pipes.

Model			MXZ-2D20NL				
Indoor type			Non-Duct (09+09)		Duct (09+12)		
Item		Unit	Cooling	Heating	Cooling	Heating	
Total	Capacity	Btu/h	18,000	22,000	20,000	22,000	
	SHF	–	–	–	–	–	
	Input	kW	1.384	1.641	2.000	1.771	
Electrical circuit	Power supply (V, phase, Hz)		208/230, 1, 60				
	Input	kW	1.335	1.577	1.823	1.705	
	Comp. current (208/230V)	A	6.42/5.80	7.58/6.86	8.76/7.92	8.20/7.41	
	Fan motor current	A	0.22	0.22	0.22	0.22	
Refrigerant circuit	Condensing pressure		PSIG	394	303	412	306
	Suction pressure		PSIG	149	94	136	79
	Discharge temperature		°F	161	149	171	157
	Condensing temperature		°F	120	99	122	100
	Suction temperature		°F	58	33	54	33
	Comp. shell bottom temp.		°F	159	146	164	150
	Ref. pipe length [Total pipe length for multi-system]		ft	25 [50]			
	Refrigerant charge (R454B)		–	4 lb, 7 oz			
	Outdoor unit	Intake air temperature	DB	°F	95	47	95
WB			°F	75	43	75	43
Fan speed		rpm	650	700	650	700	
Airflow		CFM	1,326	1,451	1,326	1,451	

Model			MXZ-3D24NL				
Indoor type			Non-Duct (06+09+09)		Duct (12+12)		
Item		Unit	Cooling	Heating	Cooling	Heating	
Total	Capacity	Btu/h	22,000	25,000	23,600	25,000	
	SHF	–	–	–	–	–	
	Input	kW	1.606	1.879	2.017	1.879	
Electrical circuit	Power supply (V, phase, Hz)		208/230, 1, 60				
	Input	kW	1.577	1.800	1.775	1.846	
	Comp. current (208/230V)	A	7.58/6.86	8.88/8.03	8.54/7.72	8.88/8.03	
	Fan motor current	A	0.4	0.4	0.4	0.4	
Refrigerant circuit	Condensing pressure		PSIG	391	307	381	307
	Suction pressure		PSIG	159	82	143	82
	Discharge temperature		°F	155	144	155	144
	Condensing temperature		°F	116	100	116	100
	Suction temperature		°F	62	34	56	34
	Comp. shell bottom temp.		°F	154	143	154	143
	Ref. pipe length [Total pipe length for multi-system]		ft	25 [75]		25 [50]	
	Refrigerant charge (R454B)		–	5 lb, 5 oz			
	Outdoor unit	Intake air temperature	DB	°F	95	47	95
WB			°F	75	43	75	43
Fan speed		rpm	650	680	650	680	
Airflow		CFM	2,121	2,199	2,121	2,231	

Model				MXZ-4D30NL			
Indoor type				Non-Duct (06+06+09+09)		Duct (18+18)	
Item		Unit		Cooling	Heating	Cooling	Heating
Total	Capacity	Btu/h		28,600	28,600	27,400	27,600
	SHF	-		-	-	-	-
	Input	kW		2.200	2.149	2.854	2.200
Electrical circuit	Power supply (V, phase, Hz)			208/230, 1, 60			
	Input	kW		2.190	1.775	2.447	1.968
	Comp. current (208/230V)		A	10.53/9.52	8.53/7.72	11.76/10.64	9.46/8.56
	Fan motor current		A	0.4	0.4	0.4	0.4
Refrigerant circuit	Condensing pressure		PSIG	400	263	406	269
	Suction pressure		PSIG	161	90	141	79
	Discharge temperature		°F	160	141	167	150
	Condensing temperature		°F	37	87	121	93
	Suction temperature		°F	63	33	55	34
	Comp. shell bottom temp.		°F	159	140	166	148
	Ref. pipe length [Total pipe length for multi-system]		ft	25 [100]		25 [50]	
	Refrigerant charge (R454B)		-	5 lb, 5 oz			
Outdoor unit	Intake air temperature	DB	°F	95	47	95	47
		WB	°F	75	43	75	43
	Fan speed		rpm	650	680	650	680
	Airflow		CFM	2,121	2,231	2,121	2,231

Model				MXZ-5D36NL			
Indoor type				Non-Duct (06+06+06+09+09)		Duct (18+18)	
Item		Unit		Cooling	Heating	Cooling	Heating
Total	Capacity	Btu/h		35,400	36,000	31,400	34,400
	SHF	-		-	-	-	-
	Input	kW		2.950	3.015	3.569	3.253
Electrical circuit	Power supply (V, phase, Hz)			208/230, 1, 60			
	Input	kW		2.929	2.624	3.559	3.202
	Comp. current (208/230V)		A	14.08/12.73	12.62/11.41	17.11/15.48	15.39/13.92
	Fan motor current		A	0.4	0.4	0.4	0.4
Refrigerant circuit	Condensing pressure		PSIG	403	254	383	286
	Suction pressure		PSIG	155	88	187	95
	Discharge temperature		°F	179	147	180	147
	Condensing temperature		°F	122	88	119	98
	Suction temperature		°F	70	34	72	34
	Comp. shell bottom temp.		°F	178	146	179	147
	Ref. pipe length [Total pipe length for multi-system]		ft	25 [125]		25 [50]	
	Refrigerant charge (R454B)		-	6 lb, 3 oz			
Outdoor unit	Intake air temperature	DB	°F	95	47	95	47
		WB	°F	75	43	75	43
	Fan speed		rpm	740	740	740	740
	Airflow		CFM	2,307	2,307	2,307	2,307

Model			MXZ-5D42NL				
Indoor type			Non-Duct (06+09+09+09+09)		Duct (24+24)		
Item		Unit	Cooling	Heating	Cooling	Heating	
Total	Capacity	Btu/h	40,500	45,000	36,400	41,000	
	SHF	–	–	–	–	–	
	Input	kW	4.355	4.397	4.045	4.518	
Electrical circuit	Power supply (V, phase, Hz)		208/230, 1, 60				
	Input	kW	4.112	3.900	4.019	4.303	
	Comp. current (208/230V)	A	19.77/17.88	18.75/16.96	19.32/17.47	20.69/18.71	
	Fan motor current	A	0.4	0.4	0.4	0.4	
Refrigerant circuit	Condensing pressure		PSIG	418	261	414	309
	Suction pressure		PSIG	134	80	127	86
	Discharge temperature		°F	186	149	180	180
	Condensing temperature		°F	125	90	125	103
	Suction temperature		°F	59	27	53	45
	Comp. shell bottom temp.		°F	184	147	178	178
	Ref. pipe length [Total pipe length for multi-system]		ft	25 [125]		25 [50]	
	Refrigerant charge (R454B)		–	6 lb, 3 oz			
	Outdoor unit	Intake air temperature	DB	°F	95	47	95
WB			°F	75	43	75	43
Fan speed		rpm	780	780	780	800	
Airflow		CFM	2,446	2,446	2,446	2,516	

Model			MXZ-2D20NLHZ				
Indoor type			Non-Duct (09+09)		Duct (09+12)		
Item		Unit	Cooling	Heating	Cooling	Heating	
Total	Capacity	Btu/h	18,000	22,000	20,000	22,000	
	SHF	–	–	–	–	–	
	Input	kW	1.334	1.612	1.800	1.688	
Electrical circuit	Power supply (V, phase, Hz)		208/230, 1, 60				
	Input	kW	1.260	1.552	1.773	1.632	
	Comp. current (208/230V)	A	6.06/5.48	7.46/6.75	8.52/7.71	7.85/7.10	
	Fan motor current	A	0.4	0.4	0.4	0.4	
Refrigerant circuit	Condensing pressure		PSIG	370	303	377	331
	Suction pressure		PSIG	149	99	131	99
	Discharge temperature		°F	156	127	152	148
	Condensing temperature		°F	112	97	113	104
	Suction temperature		°F	59	35	51	36
	Comp. shell bottom temp.		°F	153	125	150	146
	Ref. pipe length [Total pipe length for multi-system]		ft	25 [50]		25 [50]	
	Refrigerant charge (R454B)		–	5 lb, 5 oz			
	Outdoor unit	Intake air temperature	DB	°F	95	47	95
WB			°F	75	43	75	43
Fan speed		rpm	650	680	650	680	
Airflow		CFM	2,121	2,231	2,121	2,231	

Model				MXZ-3D24NLHZ			
Indoor type				Non-Duct (06+06+09)		Duct (12+12)	
Item			Unit	Cooling	Heating	Cooling	Heating
Total	Capacity		Btu/h	22,000	25,000	23,600	24,600
	SHF		-	-	-	-	-
	Input		kW	1.693	2.094	2.360	2.185
Electrical circuit	Power supply (V, phase, Hz)			208/230, 1, 60			
	Input		kW	1.501	1.658	2.341	2.172
	Comp. current (208/230V)		A	7.21/6.52	7.97/7.21	11.26/10.18	10.44/9.45
	Fan motor current		A	0.4	0.4	0.4	0.4
Refrigerant circuit	Condensing pressure		PSIG	354	255	371	333
	Suction pressure		PSIG	167	99	126	99
	Discharge temperature		°F	150	148	165	153
	Condensing temperature		°F	112	89	116	108
	Suction temperature		°F	64	40	53	36
	Comp. shell bottom temp.		°F	149	145	163	151
	Ref. pipe length [Total pipe length for multi-system]		ft	25 [75]		25 [50]	
	Refrigerant charge (R454B)		-	6 lb, 3 oz			
Outdoor unit	Intake air temperature	DB	°F	95	47	95	47
		WB	°F	75	43	75	43
	Fan speed		rpm	720	760	720	760
	Airflow		CFM	2,238	2,376	2,238	2,376

Model				MXZ-3D30NLHZ			
Indoor type				Non-Duct (09+09+12)		Duct (18+18)	
Item			Unit	Cooling	Heating	Cooling	Heating
Total	Capacity		Btu/h	28,400	28,600	27,400	27,600
	SHF		-	-	-	-	-
	Input		kW	2.470	2.395	2.661	2.286
Electrical circuit	Power supply (V, phase, Hz)			208/230, 1, 60			
	Input		kW	2.440	2.058	2.331	2.255
	Comp. current (208/230V)		A	11.73/10.61	9.89/8.95	11.21/10.13	10.84/9.80
	Fan motor current		A	0.4	0.4	0.4	0.4
Refrigerant circuit	Condensing pressure		PSIG	387	277	375	271
	Suction pressure		PSIG	142	94	144	97
	Discharge temperature		°F	162	151	172	141
	Condensing temperature		°F	119	94	117	94
	Suction temperature		°F	54	36	67	36
	Comp. shell bottom temp.		°F	161	148	170	138
	Ref. pipe length [Total pipe length for multi-system]		ft	25 [75]		25 [50]	
	Refrigerant charge (R454B)		-	6 lb, 3 oz			
Outdoor unit	Intake air temperature	DB	°F	95	47	95	47
		WB	°F	75	43	75	43
	Fan speed		rpm	720	760	720	760
	Airflow		CFM	2,238	2,376	2,238	2,376

9-1. OPERATING RANGE

(1) POWER SUPPLY

	Model		Rating	Guaranteed Voltage
Outdoor unit	MXZ-2D20NL MXZ-3D24NL MXZ-4D30NL MXZ-5D36NL MXZ-5D42NL	MXZ-2D20NLHZ MXZ-3D24NLHZ MXZ-3D30NLHZ	208/230 V 60 Hz 1ø	Min. 198 V 208 V 230 V Max. 253 V 

(2) OPERATION

Function	Intake air temperature Condition	Indoor		Outdoor	
		DB (°F)	WB (°F)	DB (°F)	WB (°F)
Cooling	"A _{Full} " Cooling steady state at rated compressor speed	80	67	95	(75)
	"B _{Full} " Cooling steady state at rated compressor speed	80	67	82	(65)
	"B _{Low} " Cooling steady state at minimum compressor speed	80	67	82	(65)
	Low ambient cooling steady state at minimum compressor speed	80	67	67	(53.5)
	Intermediate cooling steady state at intermediate compressor speed	80	67	87	(69)
Heating	Standard rating-heating at rated compressor speed	70	60	47	43
	Low temperature heating at rated compressor speed	70	60	17	15
	Max. temperature heating at minimum compressor speed	70	60	62	56.5
	High temperature heating at minimum compressor speed	70	60	47	43
	Frost accumulation at intermediate compressor speed	70	60	35	33
	Very low temperature heating at maximum compressor speed	70	60	5	4

MXZ-2D20NL MXZ-3D24NL MXZ-4D30NL MXZ-5D36NL MXZ-5D42NL
MXZ-2D20NLHZ MXZ-3D24NLHZ MXZ-3D30NLHZ

The standard specifications apply only to the operation of the air conditioner under normal conditions. Since operating conditions vary according to the areas where these units are installed, the following information has been provided to clarify the operating characteristics of the air conditioner under the conditions indicated by the performance curve.

(1) GUARANTEED VOLTAGE

198 ~ 253 V 60 Hz

(2) AIR FLOW

Air flow should be set at MAX.

(3) MAIN READINGS

- | | | |
|---|------|-----------|
| (1) Indoor intake air wet-bulb temperature : | °FWB | } Cooling |
| (2) Indoor outlet air wet-bulb temperature : | °FWB | |
| (3) Outdoor intake air dry-bulb temperature : | °FDB | |
| (4) Total input: | W | |
| (5) Indoor intake air dry-bulb temperature : | °FDB | } Heating |
| (6) Outdoor intake air wet-bulb temperature : | °FWB | |
| (7) Total input : | W | |

Indoor air wet and dry bulb temperature difference on the left side of the following chart shows the difference between the indoor intake air wet and dry bulb temperature and the indoor outlet air wet and dry bulb temperature for your reference at service.

How to measure the indoor air wet and dry bulb temperature difference

1. Attach at least 2 sets of wet and dry bulb thermometers to the indoor air intake as shown in the figure, and at least 2 sets of wet and dry bulb thermometers to the indoor air outlet. The thermometers must be attached to the position where air speed is high.
2. Attach at least 2 sets of wet and dry bulb thermometers to the outdoor air intake. Cover the thermometers to prevent direct rays of the sun.
3. Check that the air filter is cleaned.
4. Open windows and doors of room.
5. Press the EMERGENCY OPERATION switch once (twice) to start the EMERGENCY COOL (HEAT) MODE.
6. When system stabilizes after more than 15 minutes, measure temperature and take an average temperature.
7. 10 minutes later, measure temperature again and check that the temperature does not change.

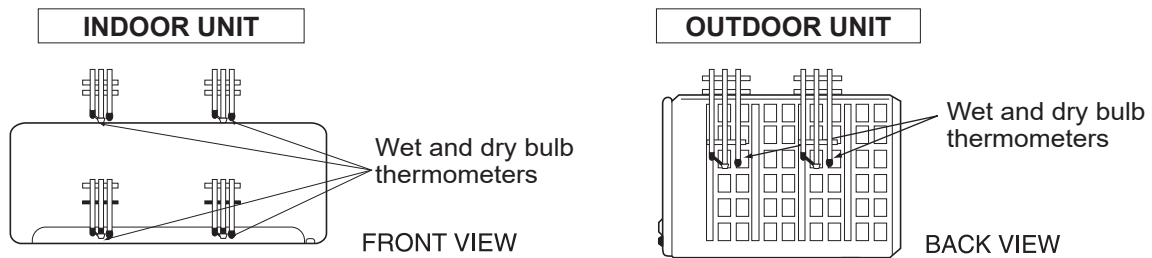

9-2. CAPACITY AND THE INPUT CURVES MXZ-2D20NL

Indoor air Wet-bulb temperature difference (°F)	4.8	7.5	10.2	10.4
	4.4	6.8	9.4	9.5
	4.1	6.2	8.5	8.7
	3.7	5.6	7.7	7.8
	3.3	5.0	6.8	7.0
	2.9	4.4	6.0	6.1
	2.5	3.9	5.2	5.3
	06 class	09 class	12 class	15 class

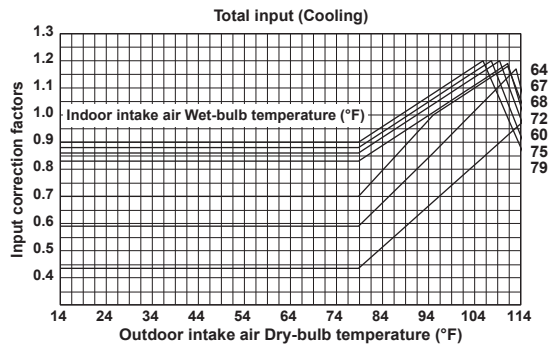
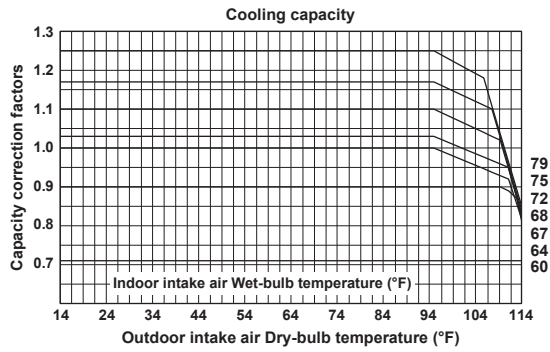

Indoor air Wet-bulb temperature difference (°F)	20.0	29.5	38.7	48.4
	18.5	27.5	36.0	45.0
	17.1	25.4	33.1	41.6
	15.7	23.2	30.4	38.0
	14.4	21.4	28.1	34.9
	13.0	19.3	25.2	31.5
	11.5	17.1	22.3	28.1
	10.1	14.9	19.6	24.5
	8.8	13.0	16.9	21.2
	7.2	10.8	14.2	17.6
	5.8	8.6	11.3	14.2
	06 class	09 class	12 class	15 class

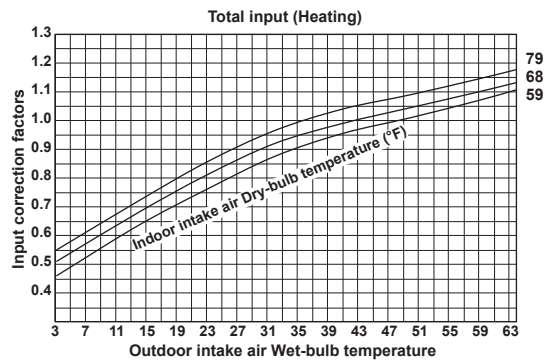
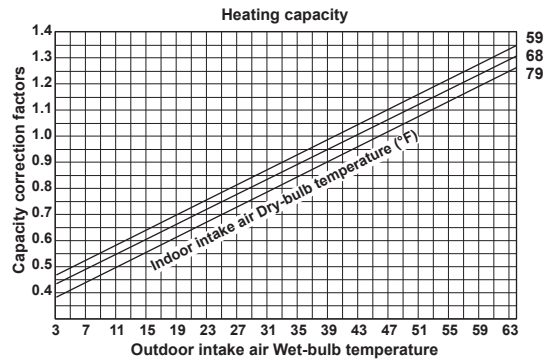

MXZ-3D24NL

MXZ-4D30NL

MXZ-5D36NL

MXZ-5D42NL

Indoor air Wet-bulb temperature difference (°F)	4.8	7.5	10.2	10.4	12.1	13.4
	4.4	6.8	9.4	9.5	11.1	12.2
	4.1	6.2	8.5	8.7	10.1	11.1
	3.7	5.6	7.7	7.8	9.1	10.0
	3.3	5.0	6.8	7.0	8.1	8.9
	2.9	4.4	6.0	6.1	7.1	7.8
	2.5	3.9	5.2	5.3	6.1	6.7
	06 class	09 class	12 class	15 class	18 class	24 class

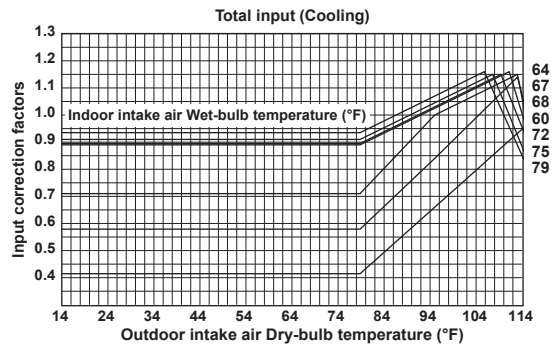
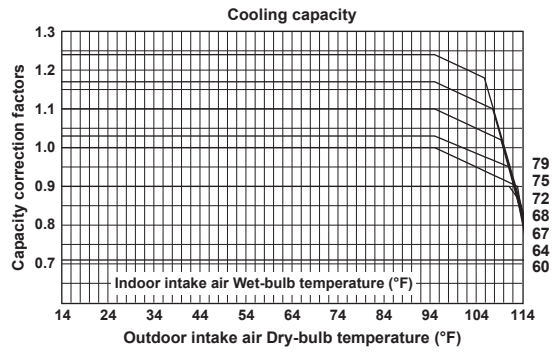

Indoor air Wet-bulb temperature difference (°F)	20.0	29.5	38.7	48.4	47.3	49.3
	18.5	27.5	36.0	45.0	43.9	45.7
	17.1	25.4	33.1	41.6	40.5	42.3
	15.7	23.2	30.4	38.0	37.1	38.7
	14.4	21.4	28.1	34.9	34.2	35.6
	13.0	19.3	25.2	31.5	30.8	32.0
	11.5	17.1	22.3	28.1	27.4	28.4
	10.1	14.9	19.6	24.5	23.9	24.8
	8.8	13.0	16.9	21.2	20.7	21.6
	7.2	10.8	14.2	17.6	17.3	18.0
	5.8	8.6	11.3	14.2	13.9	14.4
	06 class	09 class	12 class	15 class	18 class	24 class

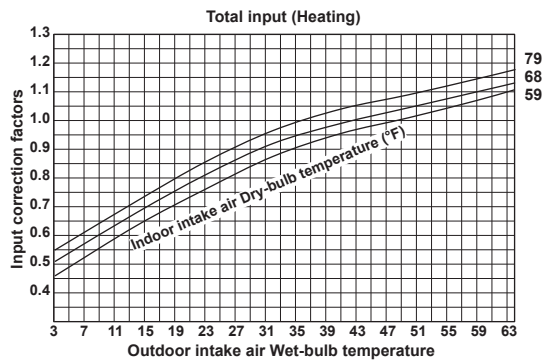
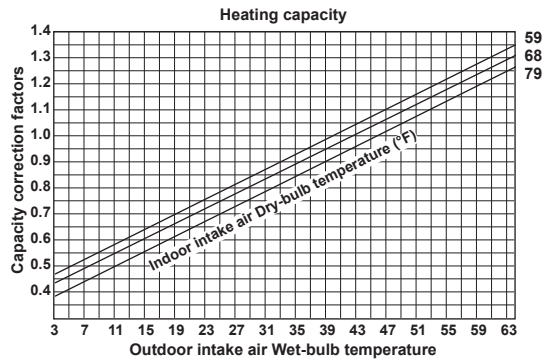

MXZ-2D20NLHZ

Indoor air Wet-bulb temperature difference (°F)	4.8	7.5	10.2	10.4
	4.4	6.8	9.4	9.5
	4.1	6.2	8.5	8.7
	3.7	5.6	7.7	7.8
	3.3	5.0	6.8	7.0
	2.9	4.4	6.0	6.1
	2.5	3.9	5.2	5.3
	06 class	09 class	12 class	15 class

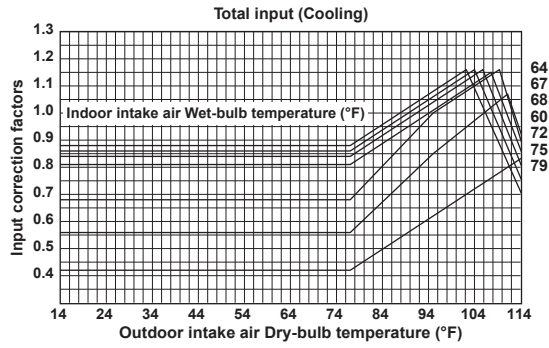
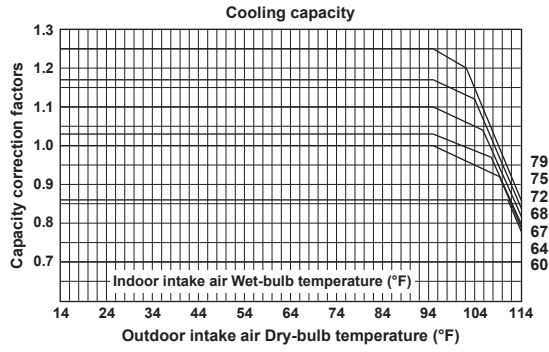

Indoor air Wet-bulb temperature difference (°F)	20.0	29.5	38.7	48.4
	18.5	27.5	36.0	45.0
	17.1	25.4	33.1	41.6
	15.7	23.2	30.4	38.0
	14.4	21.4	28.1	34.9
	13.0	19.3	25.2	31.5
	11.5	17.1	22.3	28.1
	10.1	14.9	19.6	24.5
	8.8	13.0	16.9	21.2
	7.2	10.8	14.2	17.6
	5.8	8.6	11.3	14.2
	06 class	09 class	12 class	15 class

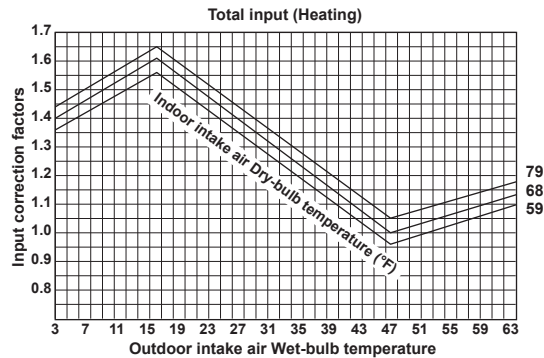
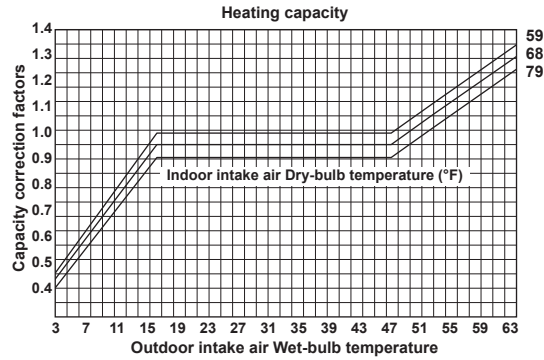

MXZ-3D24NLHZ MXZ-3D30NLHZ

	4.8	7.5	10.2	10.4	12.1	13.4
	4.4	6.8	9.4	9.5	11.1	12.2
	4.1	6.2	8.5	8.7	10.1	11.1
	3.7	5.6	7.7	7.8	9.1	10.0
	3.3	5.0	6.8	7.0	8.1	8.9
	2.9	4.4	6.0	6.1	7.1	7.8
	2.5	3.9	5.2	5.3	6.1	6.7
Indoor air Wet-bulb temperature difference (°F)						
06 class						
09 class						
12 class						
15 class						
18 class						
24 class						

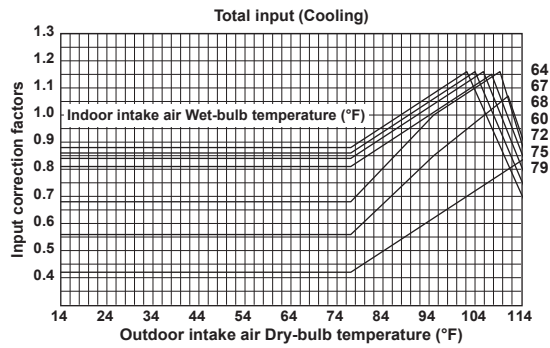
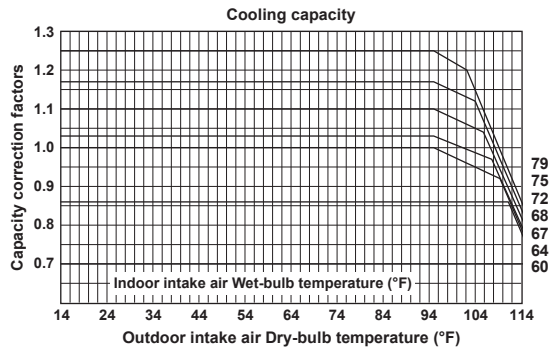

	20.0	29.5	38.7	48.4	47.3	49.3
	18.5	27.5	36.0	45.0	43.9	45.7
	17.1	25.4	33.1	41.6	40.5	42.3
	15.7	23.2	30.4	38.0	37.1	38.7
	14.4	21.4	28.1	34.9	34.2	35.6
	13.0	19.3	25.2	31.5	30.8	32.0
	11.5	17.1	22.3	28.1	27.4	28.4
	10.1	14.9	19.6	24.5	23.9	24.8
	8.8	13.0	16.9	21.2	20.7	21.6
	7.2	10.8	14.2	17.6	17.3	18.0
	5.8	8.6	11.3	14.2	13.9	14.4
Indoor air Wet-bulb temperature difference (°F)						
06 class						
09 class						
12 class						
15 class						
18 class						
24 class						

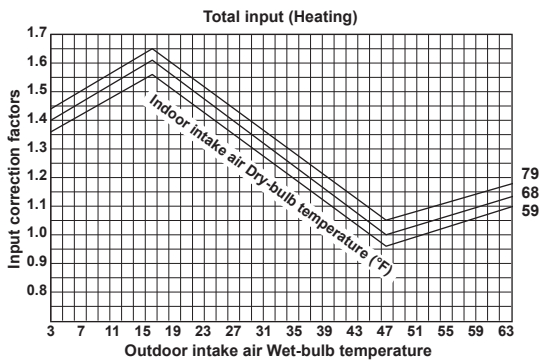
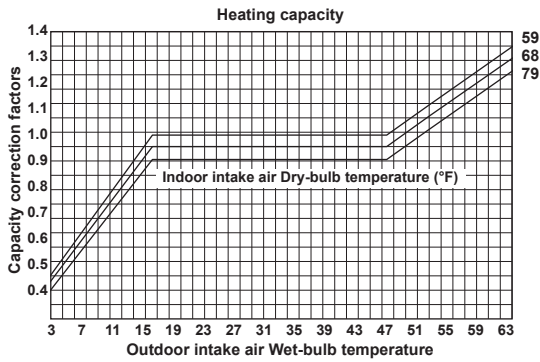

9-3. CAPACITY AND INPUT CORRECTION BY MEANS OF INVERTER OUTPUT FREQUENCY (OUTDOOR UNIT: MXZ-2D20NL)

1. 06-class unit in single operation

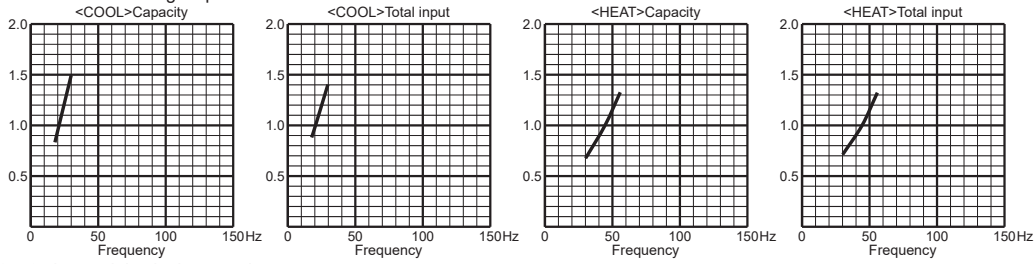

2. 09-class unit in single operation

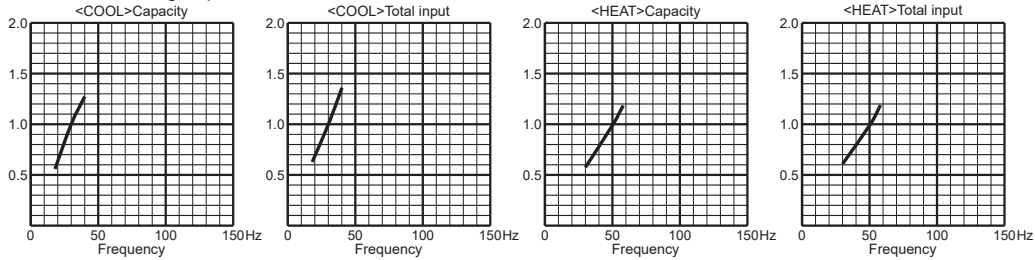

3. 12-class unit in single operation

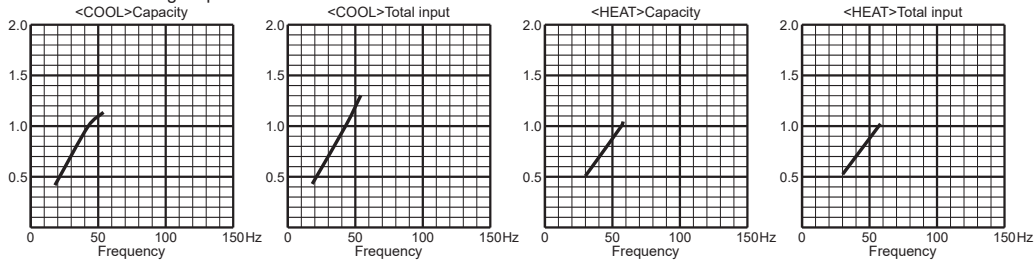

4. 15-class unit in single operation

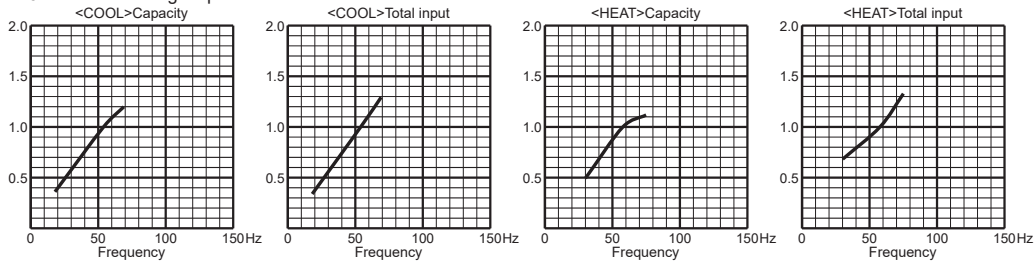

(OUTDOOR UNIT: MXZ-3D24NL MXZ-4D30NL MXZ-2D20NLHZ)

1. 06-class unit in single operation

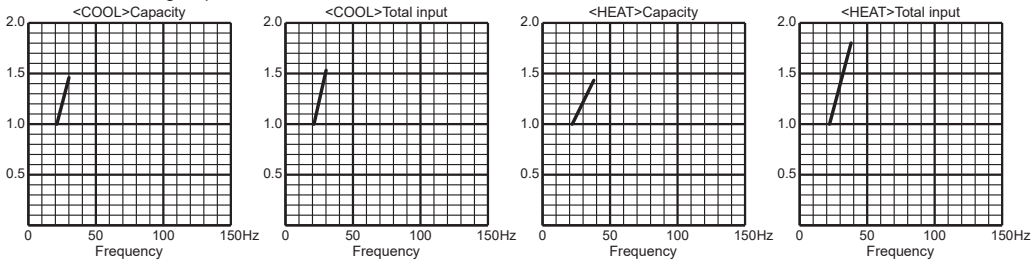

2. 09-class unit in single operation

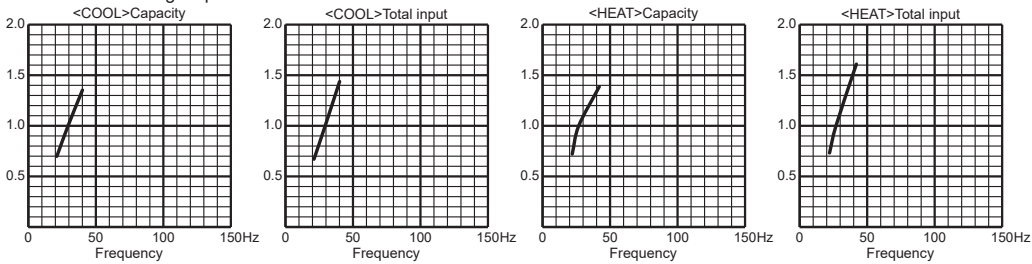

3. 12-class unit in single operation

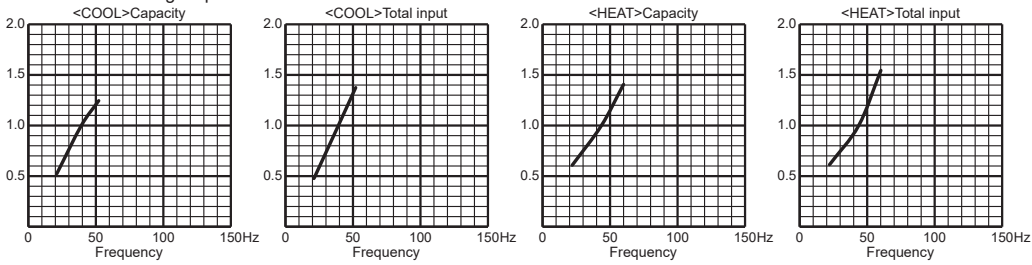

4. 15-class unit in single operation

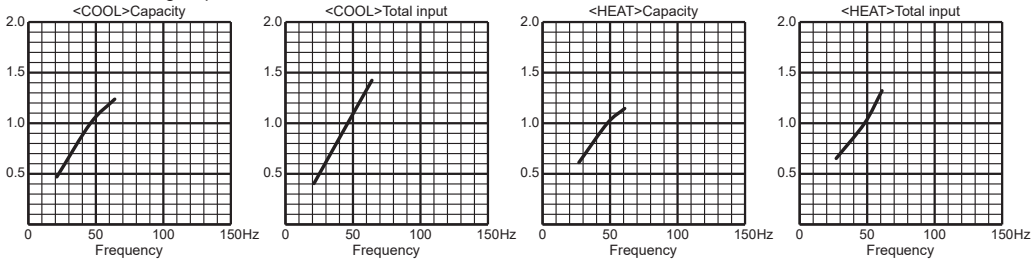

5. 18-class unit in single operation (MXZ-3D24/4D30NL only)

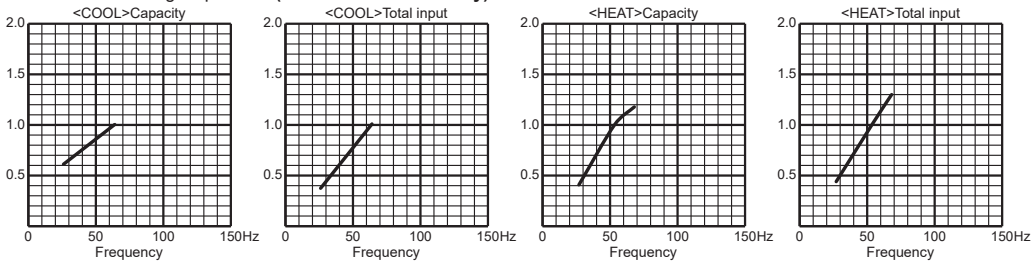

6. 24-class unit in single operation (MXZ-4D30NL only)

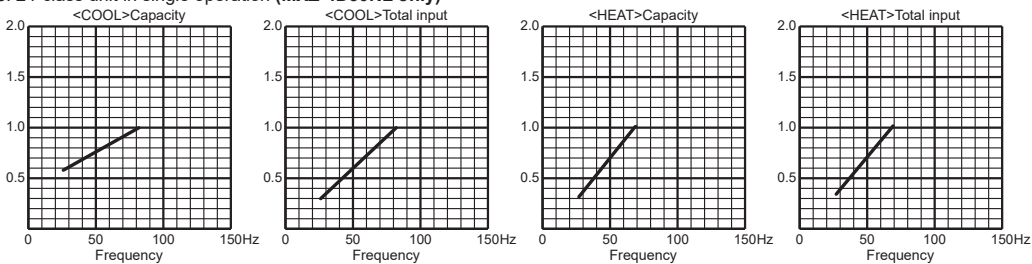

(OUTDOOR UNIT: MXZ-5D36NL MXZ-5D42NL MXZ-3D24NLHZ MXZ-3D30NLHZ)

1. 06-class unit in single operation

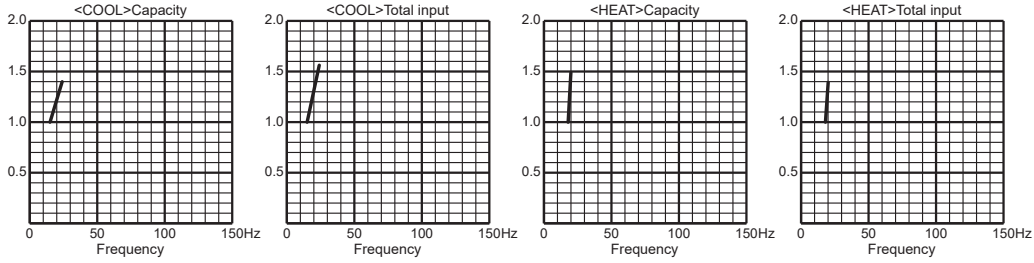

2. 09-class unit in single operation

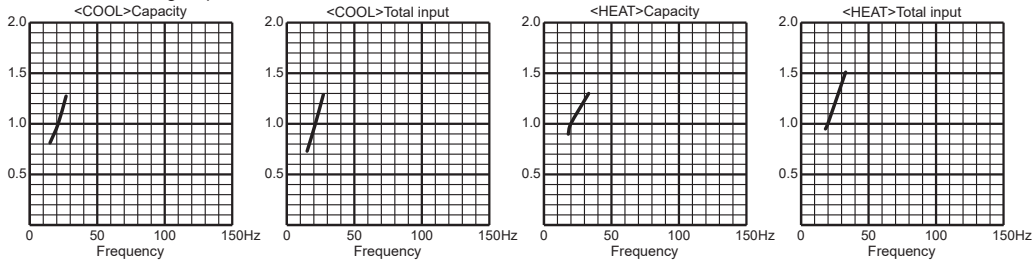

3. 12-class unit in single operation

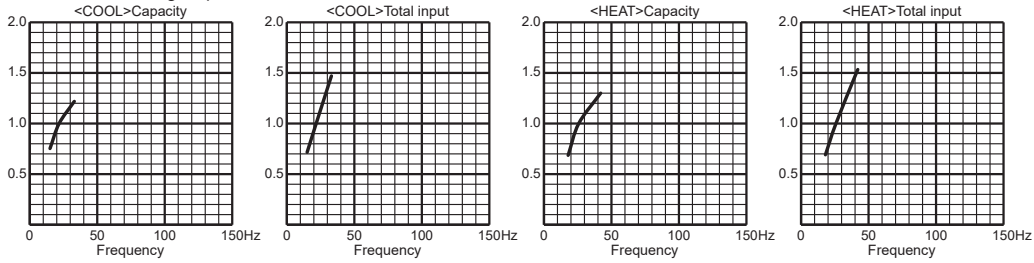

4. 15-class unit in single operation

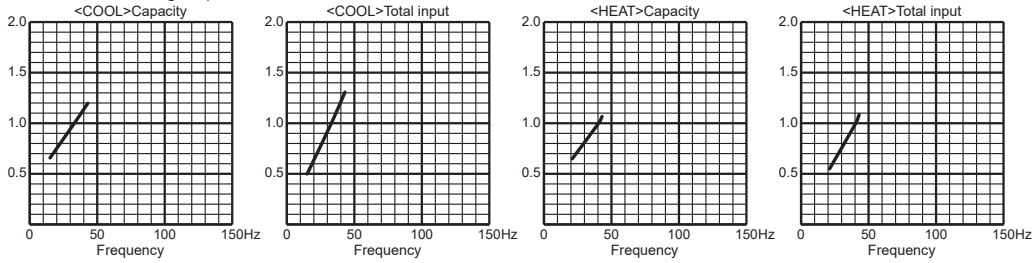

5. 18-class unit in single operation

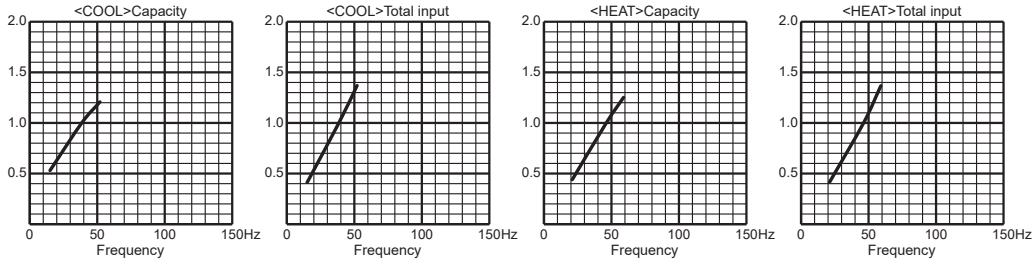

6. 24-class unit in single operation (MXZ-5D36/42NL, MXZ-3D30NLHZ only)

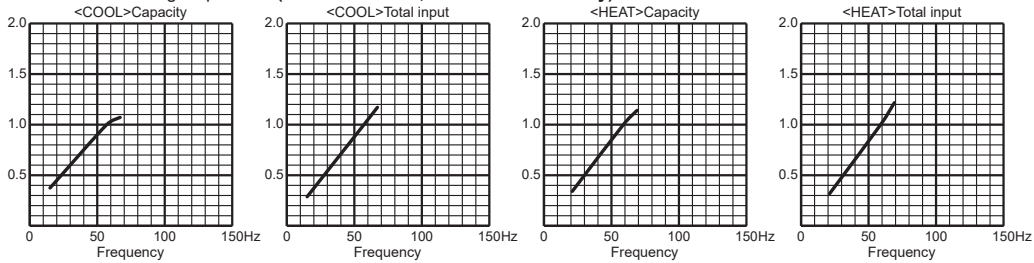

9-4. OUTDOOR LOW PRESSURE AND OUTDOOR UNIT CURRENT

1. 06-class unit in single operation (OUTDOOR UNIT: MXZ-2D20NL)

(1) COOL operation

- ① Data is based on the condition of indoor humidity 50%
- ② Air flow speed: High
- ③ Inverter output frequency: 71 Hz

<How to work fixed-frequency operation>

1. Set emergency switch to COOL or HEAT. The switch is located on indoor unit.
2. Press emergency run ON/OFF button.
3. Compressor starts running at 71 Hz (COOL) or 55 Hz (HEAT).
4. Indoor fan runs at High speed and continues for 30 minutes.
5. To cancel this operation, press emergency run ON/OFF button or any button on remote controller.

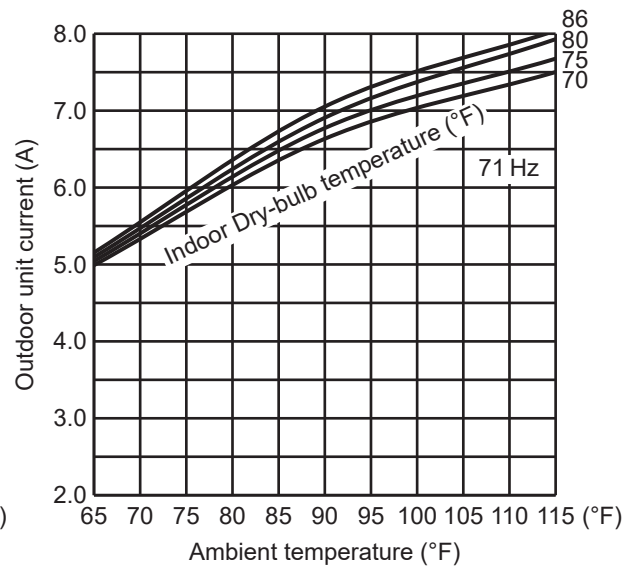
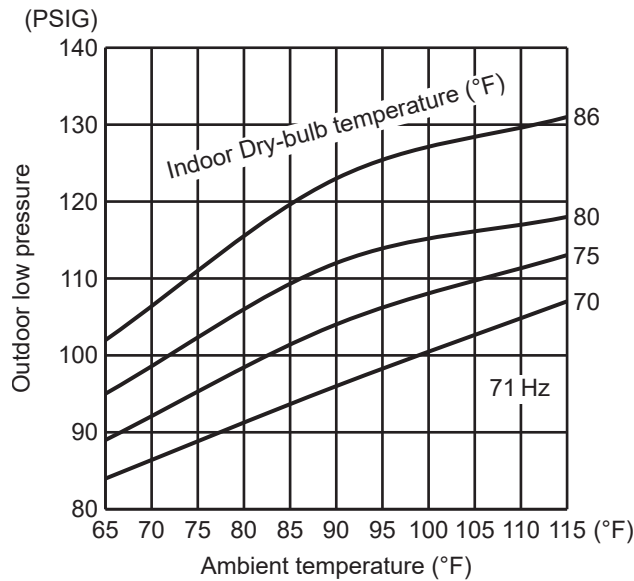

(2) HEAT operation

- ① Data is based on the condition of indoor humidity 75%
- ② Set air flow to High speed.
- ③ Inverter output frequency: 55 Hz

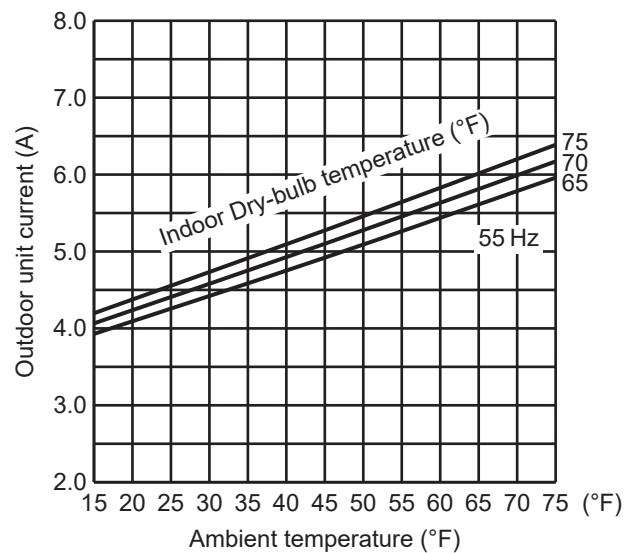

2. 09-class unit in single operation (OUTDOOR UNIT: MXZ-2D20NL)

(1) COOL operation

- ① Data is based on the condition of indoor humidity 50%
- ② Air flow speed: High
- ③ Inverter output frequency: 71 Hz

- <How to work fixed-frequency operation>
1. Set emergency switch to COOL or HEAT. The switch is located on indoor unit.
 2. Press emergency run ON/OFF button.
 3. Compressor starts running at 71 Hz (COOL) or 55 Hz (HEAT).
 4. Indoor fan runs at High speed and continues for 30 minutes.
 5. To cancel this operation, press emergency run ON/OFF button or any button on remote controller.

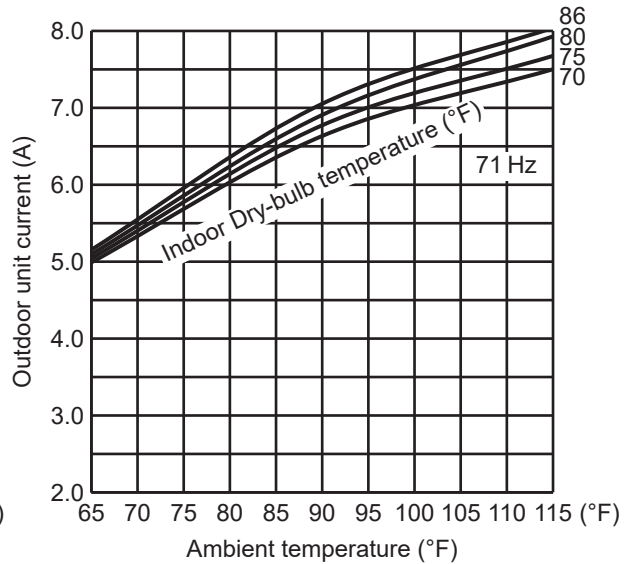
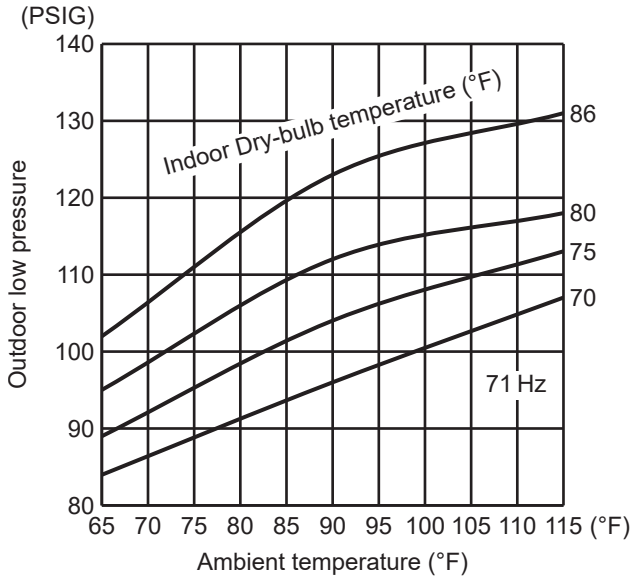

(2) HEAT operation

- ① Data is based on the condition of indoor humidity 75%
- ② Set air flow to High speed.
- ③ Inverter output frequency: 55 Hz

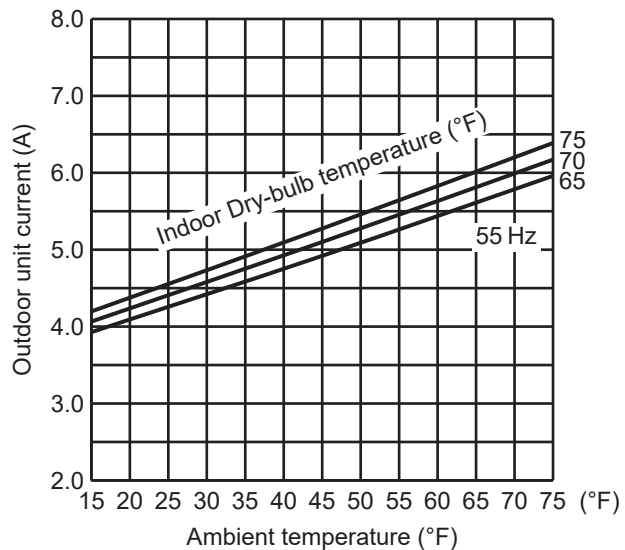

3. 12-class unit in single operation (OUTDOOR UNIT: MXZ-2D20NL)

(1) COOL operation

- ① Data is based on the condition of indoor humidity 50%
- ② Air flow speed: High
- ③ Inverter output frequency: 71 Hz

<How to work fixed-frequency operation>

1. Set emergency switch to COOL or HEAT. The switch is located on indoor unit.
2. Press emergency run ON/OFF button.
3. Compressor starts running at 71 Hz (COOL) or 55 Hz (HEAT).
4. Indoor fan runs at High speed and continues for 30 minutes.
5. To cancel this operation, press emergency run ON/OFF button or any button on remote controller.

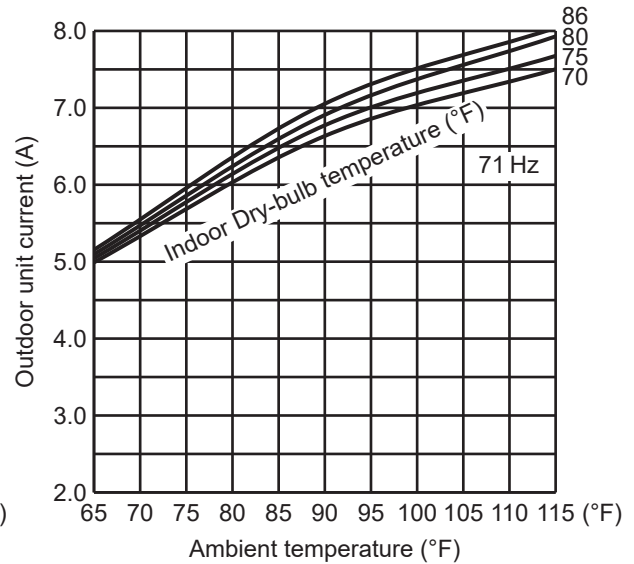
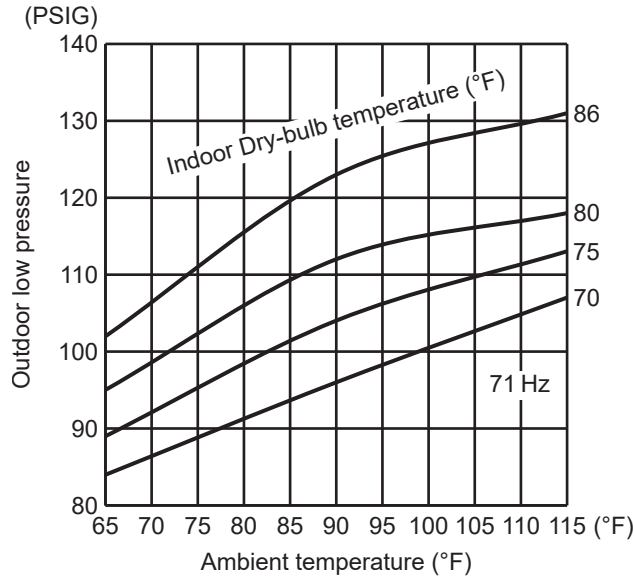

(2) HEAT operation

- ① Data is based on the condition of indoor humidity 75%
- ② Set air flow to High speed.
- ③ Inverter output frequency: 55 Hz

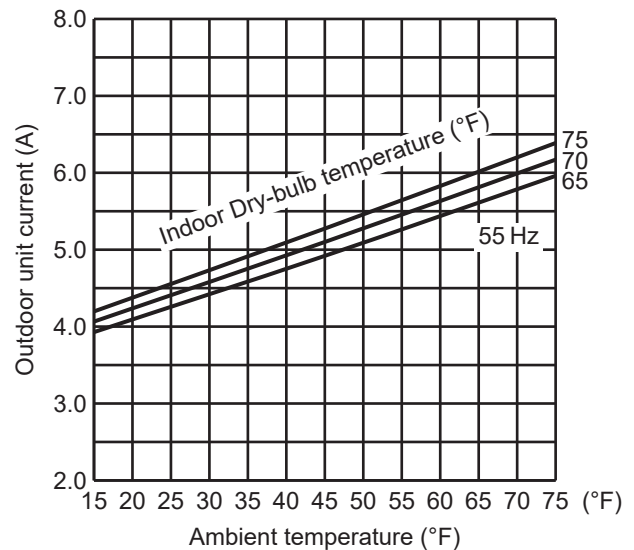

4. 15-class unit in single operation (OUTDOOR UNIT: MXZ-2D20NL)

(1) COOL operation

- ① Data is based on the condition of indoor humidity 50%
- ② Air flow speed: High
- ③ Inverter output frequency: 71 Hz

- <How to work fixed-frequency operation>
1. Set emergency switch to COOL or HEAT. The switch is located on indoor unit.
 2. Press emergency run ON/OFF button.
 3. Compressor starts running at 71 Hz (COOL) or 55 Hz (HEAT).
 4. Indoor fan runs at High speed and continues for 30 minutes.
 5. To cancel this operation, press emergency run ON/OFF button or any button on remote controller.

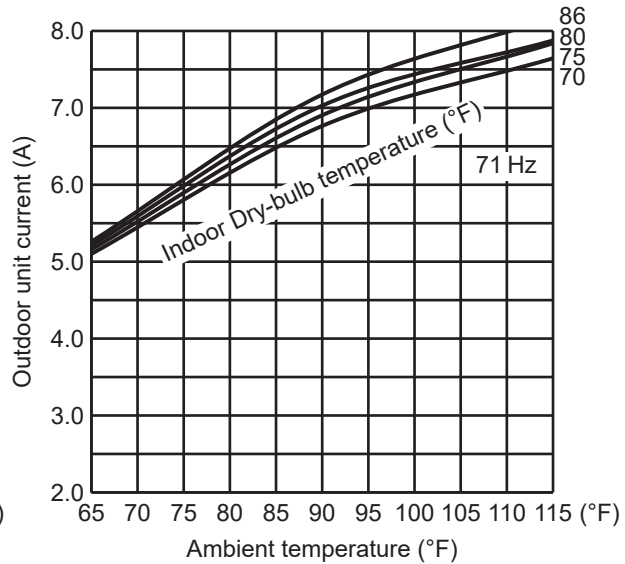
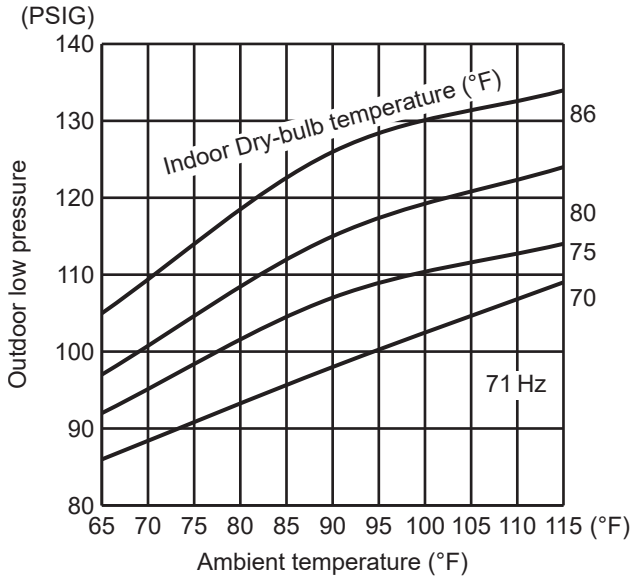

(2) HEAT operation

- ① Data is based on the condition of indoor humidity 75%
- ② Set air flow to High speed.
- ③ Inverter output frequency: 55 Hz

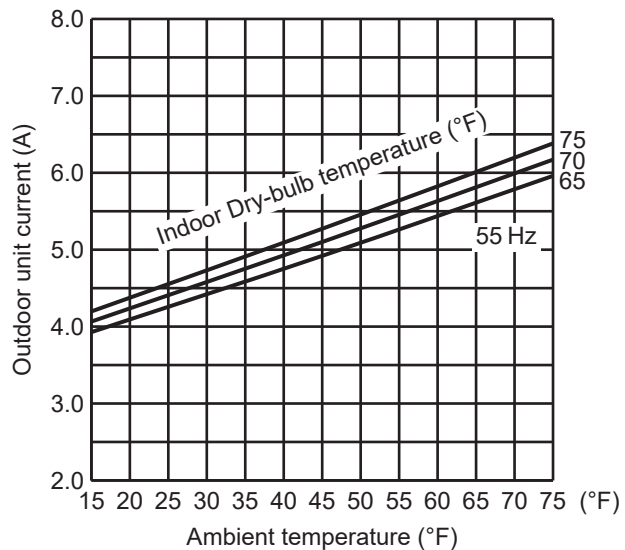

5. 06-class unit in single operation (OUTDOOR UNIT: MXZ-3D24NL MXZ-4D30NL MXZ-2D20NLHZ)

(1) COOL operation

- ① Data is based on the condition of indoor humidity 50%
- ② Air flow speed: High
- ③ Inverter output frequency: 48 Hz

<How to work fixed-frequency operation>

1. Set emergency switch to COOL or HEAT. The switch is located on indoor unit.
2. Press emergency run ON/OFF button.
3. Compressor starts running at 48 Hz (COOL or HEAT).
4. Indoor fan runs at High speed and continues for 30 minutes.
5. To cancel this operation, press emergency run ON/OFF button or any button on remote controller.

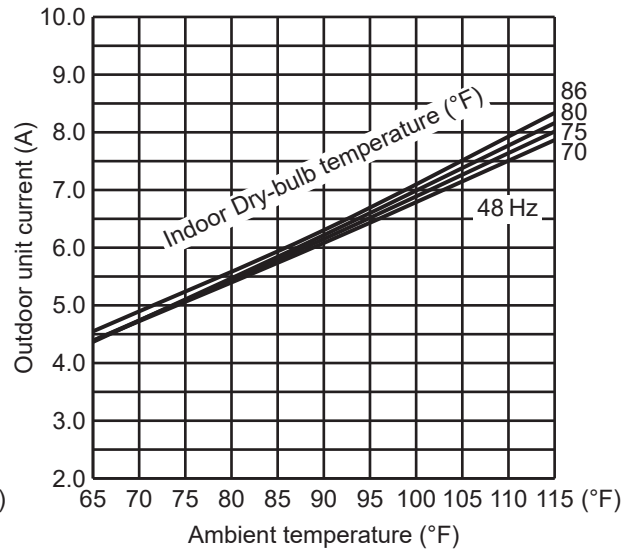
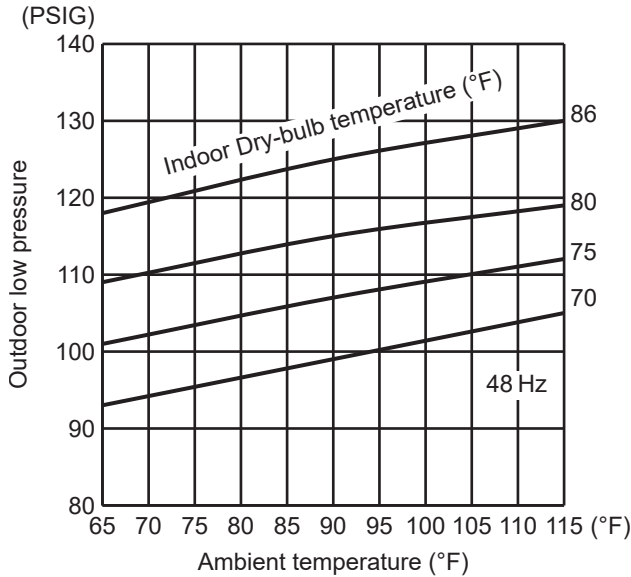

(2) HEAT operation

- ① Data is based on the condition of outdoor humidity 75%.
- ② Set air flow to High speed.
- ③ Inverter output frequency is 48 Hz.

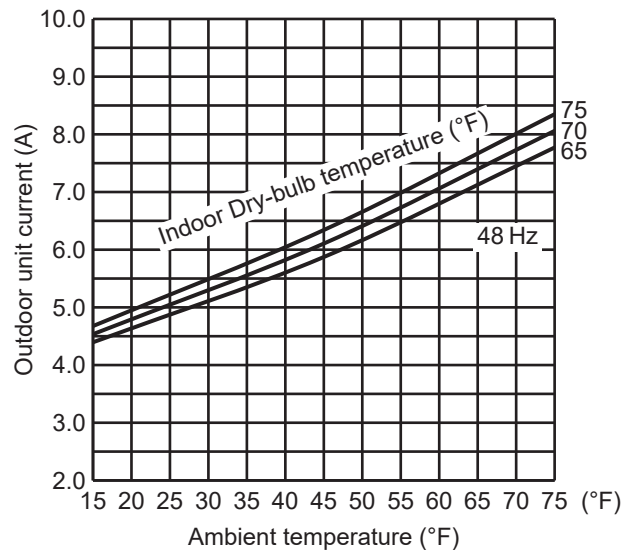

6. 09-class unit in single operation (OUTDOOR UNIT: MXZ-3D24NL MXZ-4D30NL MXZ-2D20NLHZ)

(1) COOL operation

- ① Data is based on the condition of indoor humidity 50%
- ② Air flow speed: High
- ③ Inverter output frequency: 48 Hz

<How to work fixed-frequency operation>

1. Set emergency switch to COOL or HEAT. The switch is located on indoor unit.
2. Press emergency run ON/OFF button.
3. Compressor starts running at 48 Hz (COOL or HEAT).
4. Indoor fan runs at High speed and continues for 30 minutes.
5. To cancel this operation, press emergency run ON/OFF button or any button on remote controller.

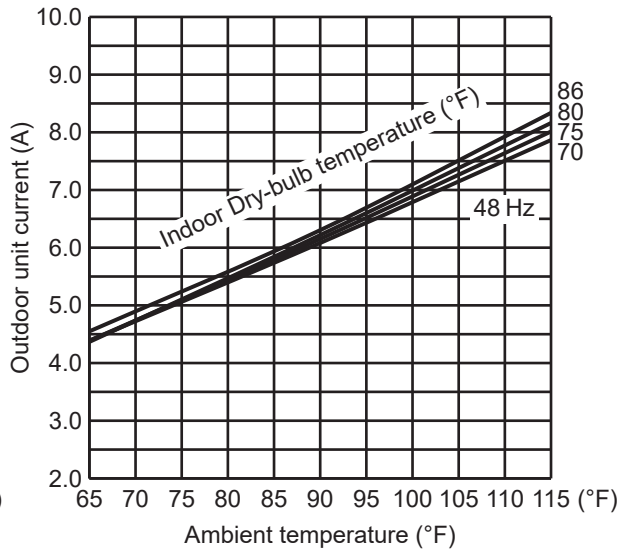
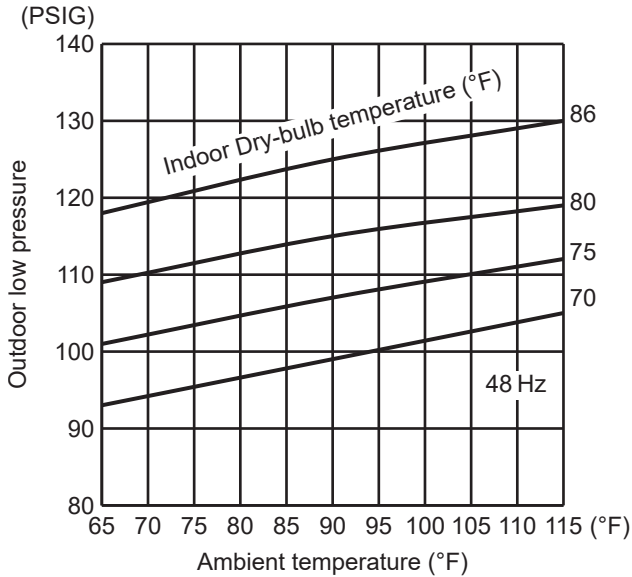

(2) HEAT operation

- ① Data is based on the condition of outdoor humidity 75%.
- ② Set air flow to High speed.
- ③ Inverter output frequency is 48 Hz.

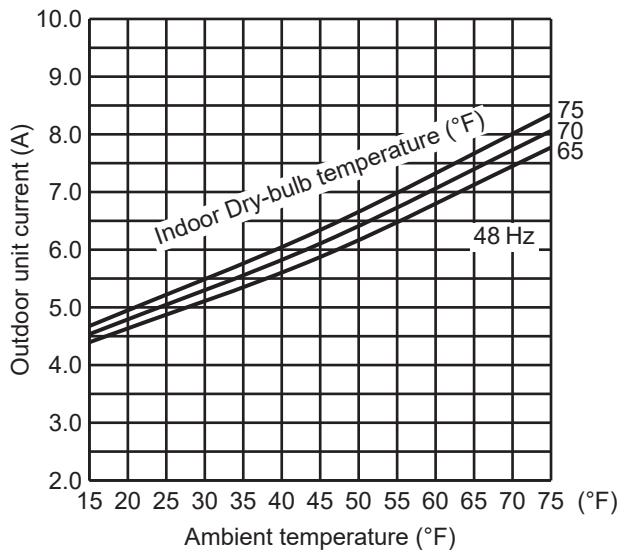

7. 12-class unit in single operation (OUTDOOR UNIT: MXZ-3D24NL MXZ-4D30NL MXZ-2D20NLHZ)

(1) COOL operation

- ① Data is based on the condition of indoor humidity 50%
- ② Air flow speed: High
- ③ Inverter output frequency: 48 Hz

<How to work fixed-frequency operation>

1. Set emergency switch to COOL or HEAT. The switch is located on indoor unit.
2. Press emergency run ON/OFF button.
3. Compressor starts running at 48 Hz (COOL or HEAT).
4. Indoor fan runs at High speed and continues for 30 minutes.
5. To cancel this operation, press emergency run ON/OFF button or any button on remote controller.

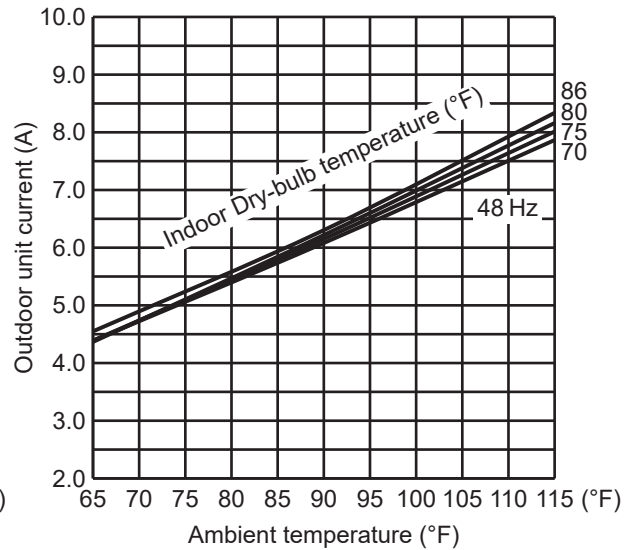
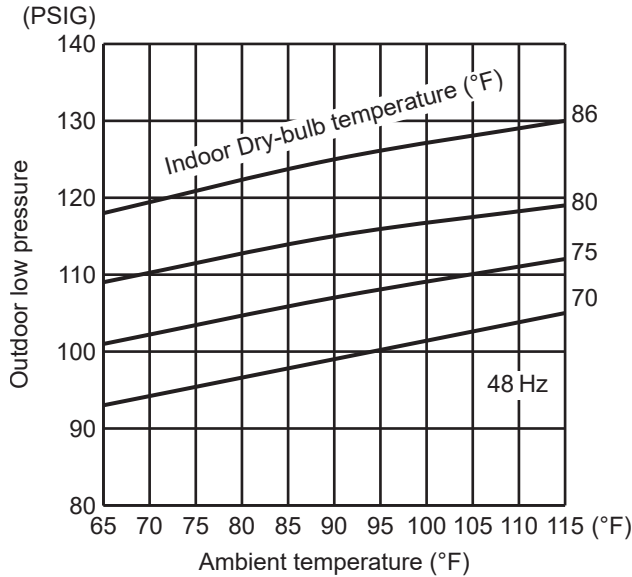

(2) HEAT operation

- ① Data is based on the condition of outdoor humidity 75%.
- ② Set air flow to High speed.
- ③ Inverter output frequency is 48 Hz.

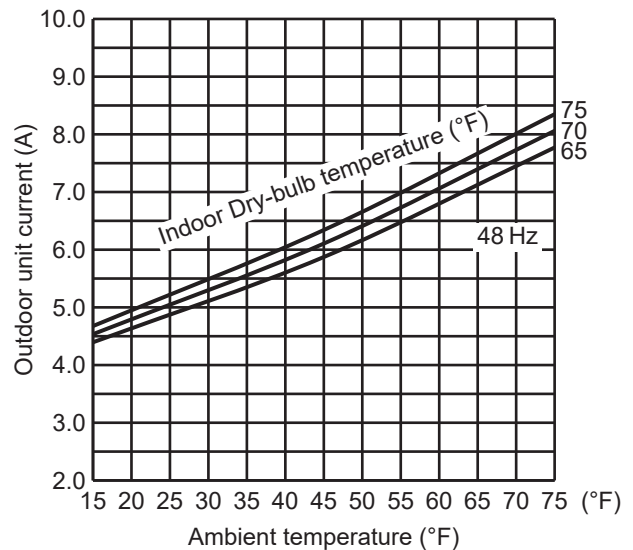

8. 15-class unit in single operation (OUTDOOR UNIT: MXZ-3D24NL MXZ-4D30NL MXZ-2D20NLHZ)

(1) COOL operation

- ① Data is based on the condition of indoor humidity 50%
- ② Air flow speed: High
- ③ Inverter output frequency: 48 Hz

- <How to work fixed-frequency operation>
1. Set emergency switch to COOL or HEAT. The switch is located on indoor unit.
 2. Press emergency run ON/OFF button.
 3. Compressor starts running at 48 Hz (COOL or HEAT).
 4. Indoor fan runs at High speed and continues for 30 minutes.
 5. To cancel this operation, press emergency run ON/OFF button or any button on remote controller.

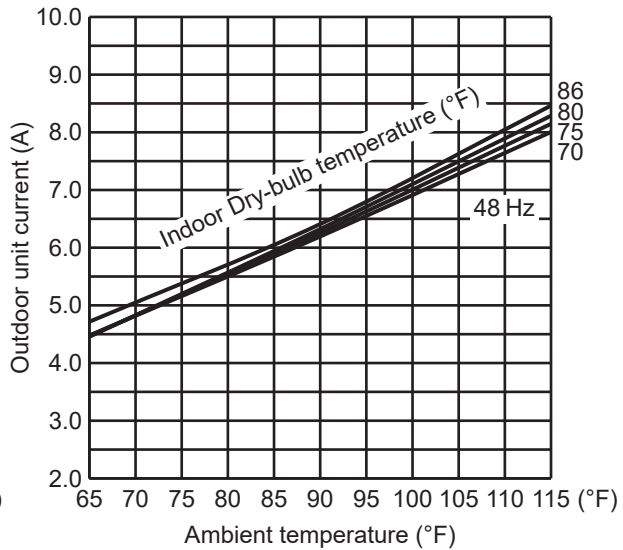
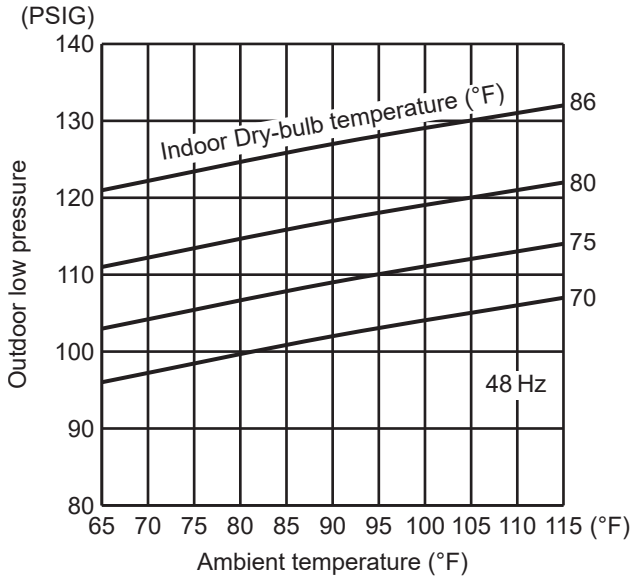

(2) HEAT operation

- ① Data is based on the condition of outdoor humidity 75%.
- ② Set air flow to High speed.
- ③ Inverter output frequency is 48 Hz.

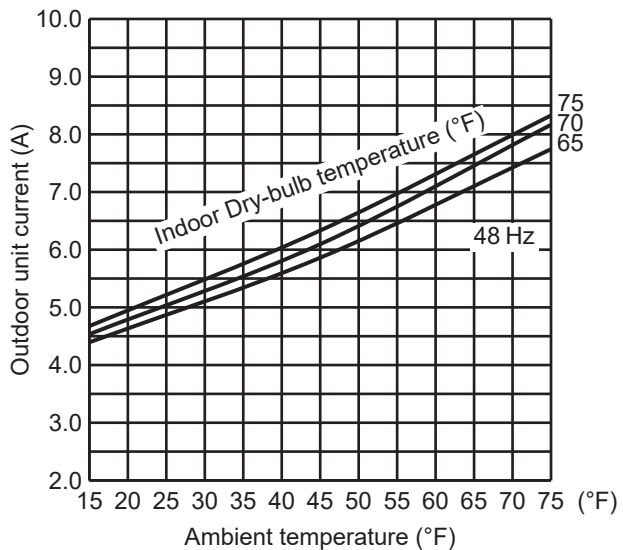

9. 18-class unit in single operation (OUTDOOR UNIT: MXZ-3D24NL MXZ-4D30NL)

(1) COOL operation

- ① Data is based on the condition of indoor humidity 50%
- ② Air flow speed: High
- ③ Inverter output frequency: 48 Hz

<How to work fixed-frequency operation>

1. Set emergency switch to COOL or HEAT. The switch is located on indoor unit.
2. Press emergency run ON/OFF button.
3. Compressor starts running at 48 Hz (COOL or HEAT).
4. Indoor fan runs at High speed and continues for 30 minutes.
5. To cancel this operation, press emergency run ON/OFF button or any button on remote controller.

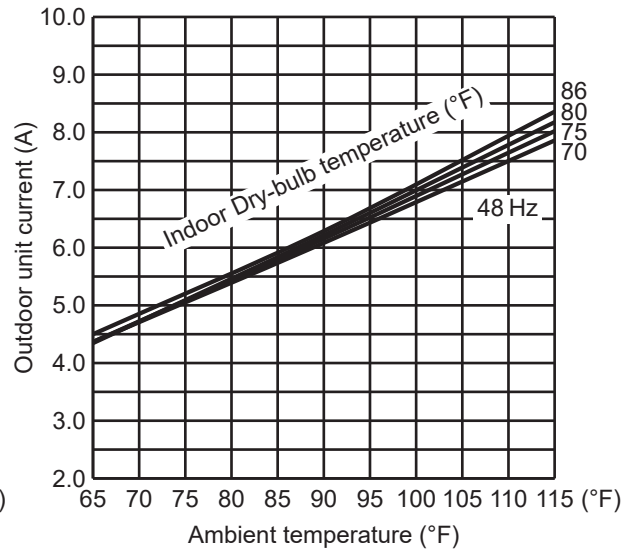
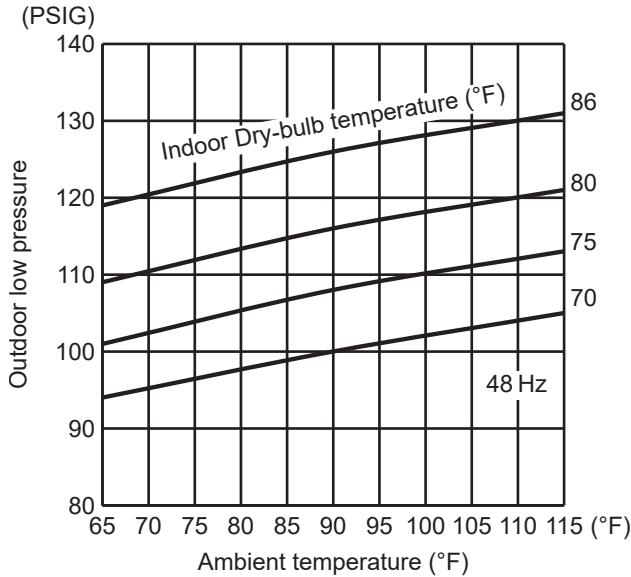

(2) HEAT operation

- ① Data is based on the condition of outdoor humidity 75%.
- ② Set air flow to High speed.
- ③ Inverter output frequency is 48 Hz.

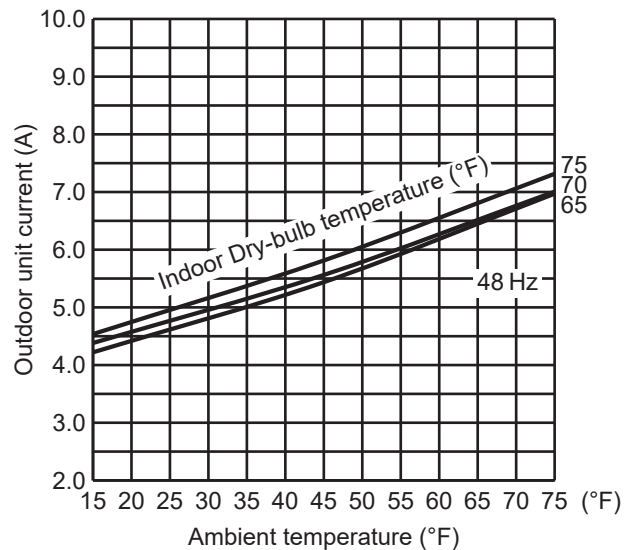

10. 24-class unit in single operation (OUTDOOR UNIT: MXZ-4D30NL)

(1) COOL operation

- ① Data is based on the condition of indoor humidity 50%
- ② Air flow speed: High
- ③ Inverter output frequency: 48 Hz

<How to work fixed-frequency operation>

1. Set emergency switch to COOL or HEAT. The switch is located on indoor unit.
2. Press emergency run ON/OFF button.
3. Compressor starts running at 48 Hz (COOL or HEAT).
4. Indoor fan runs at High speed and continues for 30 minutes.
5. To cancel this operation, press emergency run ON/OFF button or any button on remote controller.

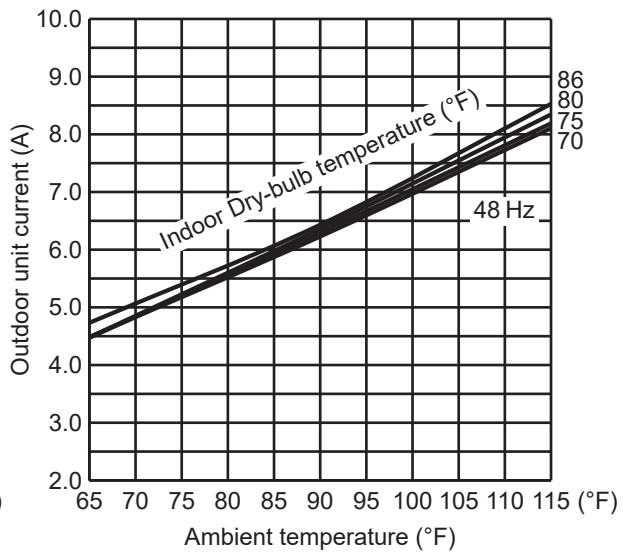
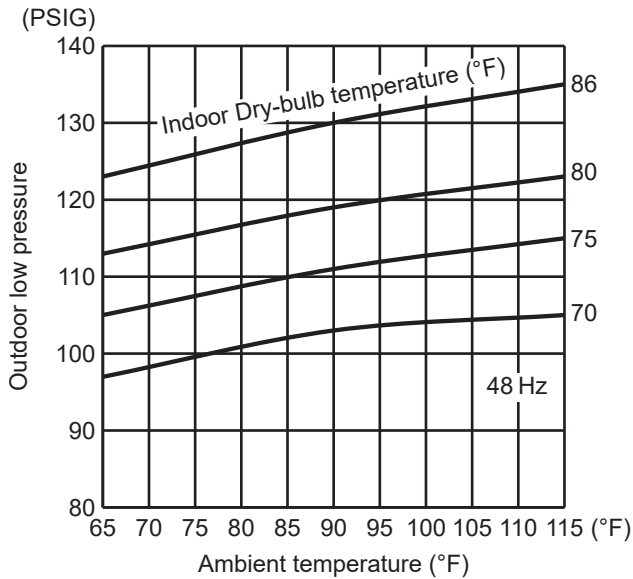

(2) HEAT operation

- ① Data is based on the condition of outdoor humidity 75%.
- ② Set air flow to High speed.
- ③ Inverter output frequency is 48 Hz.

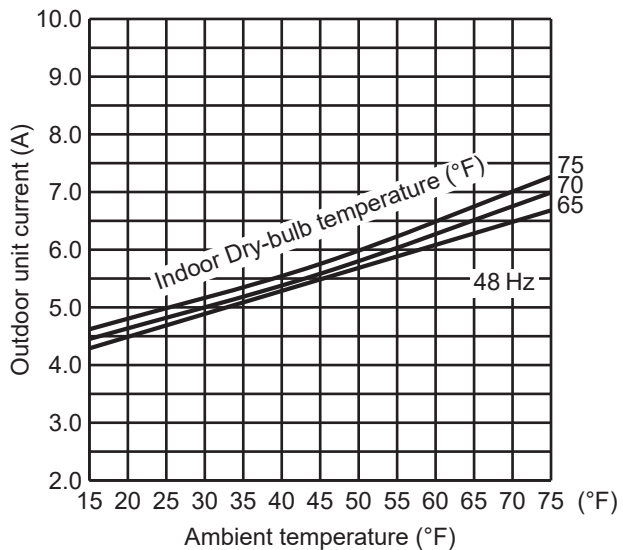

11. 06-class unit in single operation

(OUTDOOR UNIT: MXZ-5D36NL MXZ-5D42NL MXZ-3D24NLHZ MXZ-3D30NLHZ)

(1) COOL operation

- ① Data is based on the condition of indoor humidity 50%
- ② Air flow speed: High
- ③ Inverter output frequency: 43 Hz

<How to work fixed-frequency operation>

1. Set emergency switch to COOL or HEAT. The switch is located on indoor unit.
2. Press emergency run ON/OFF button.
3. Compressor starts running at 43 Hz (COOL) or 38 Hz (HEAT).
4. Indoor fan runs at High speed and continues for 30 minutes.
5. To cancel this operation, press emergency run ON/OFF button or any button on remote controller.

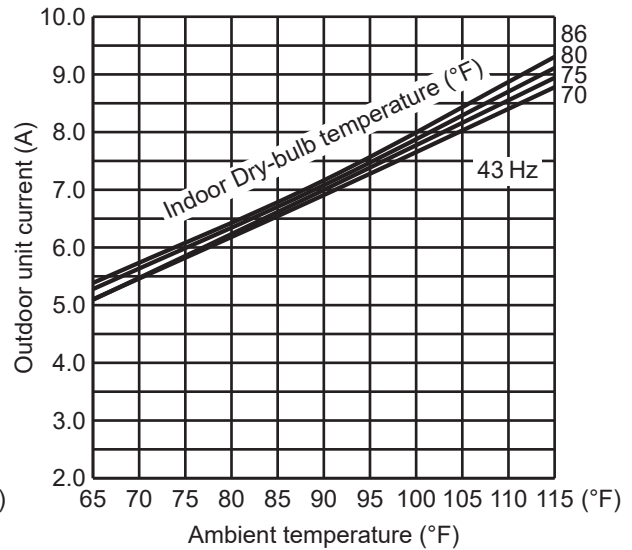
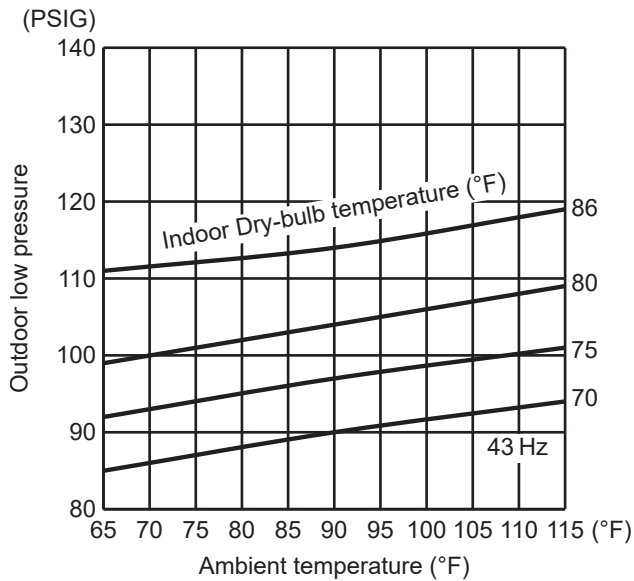

(2) HEAT operation

- ① Data is based on the condition of outdoor humidity 75%.
- ② Set air flow to High speed.
- ③ Inverter output frequency is 38 Hz.

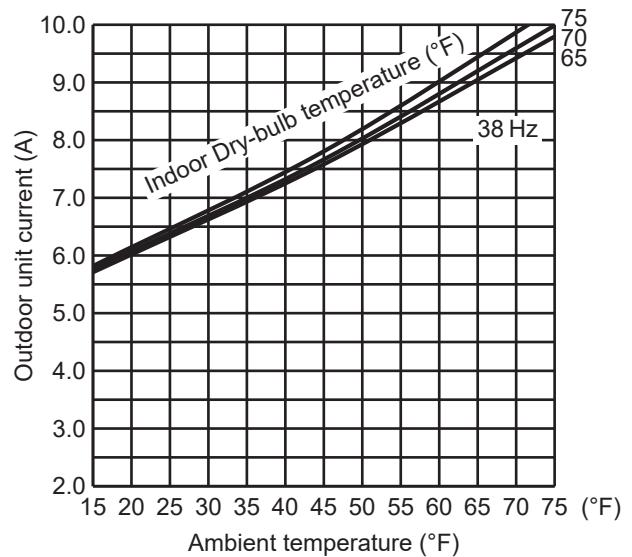

12. 09-class unit in single operation

(OUTDOOR UNIT: MXZ-5D36NL MXZ-5D42NL MXZ-3D24NLHZ MXZ-3D30NLHZ)

(1) COOL operation

- ① Data is based on the condition of indoor humidity 50%
- ② Air flow speed: High
- ③ Inverter output frequency: 43 Hz

<How to work fixed-frequency operation>

1. Set emergency switch to COOL or HEAT. The switch is located on indoor unit.
2. Press emergency run ON/OFF button.
3. Compressor starts running at 43 Hz (COOL) or 38 Hz (HEAT).
4. Indoor fan runs at High speed and continues for 30 minutes.
5. To cancel this operation, press emergency run ON/OFF button or any button on remote controller.

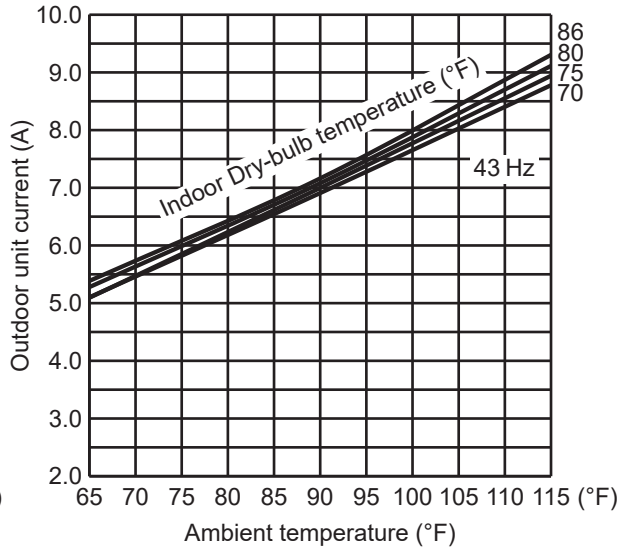
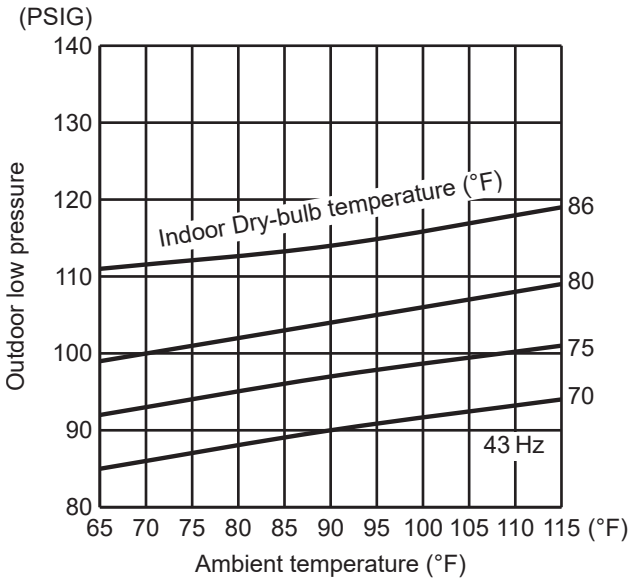

(2) HEAT operation

- ① Data is based on the condition of outdoor humidity 75%.
- ② Set air flow to High speed.
- ③ Inverter output frequency is 38 Hz.

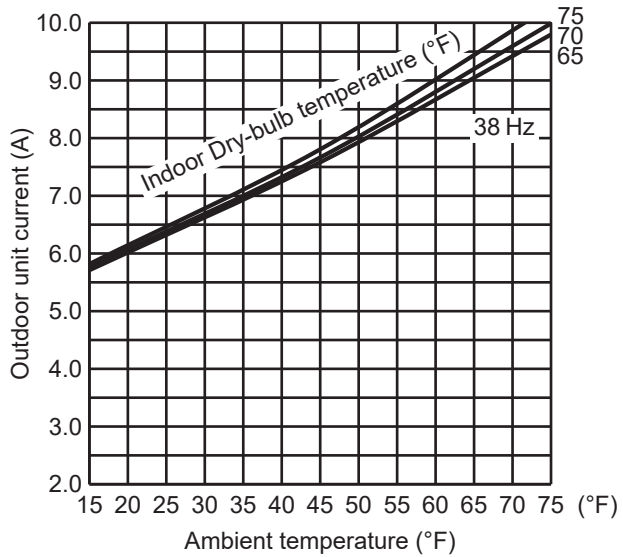

13. 12-class unit in single operation

(OUTDOOR UNIT: MXZ-5D36NL MXZ-5D42NL MXZ-3D24NLHZ MXZ-3D30NLHZ)

(1) COOL operation

- ① Data is based on the condition of indoor humidity 50%
- ② Air flow speed: High
- ③ Inverter output frequency: 43 Hz

<How to work fixed-frequency operation>

1. Set emergency switch to COOL or HEAT. The switch is located on indoor unit.
2. Press emergency run ON/OFF button.
3. Compressor starts running at 43 Hz (COOL) or 38 Hz (HEAT).
4. Indoor fan runs at High speed and continues for 30 minutes.
5. To cancel this operation, press emergency run ON/OFF button or any button on remote controller.

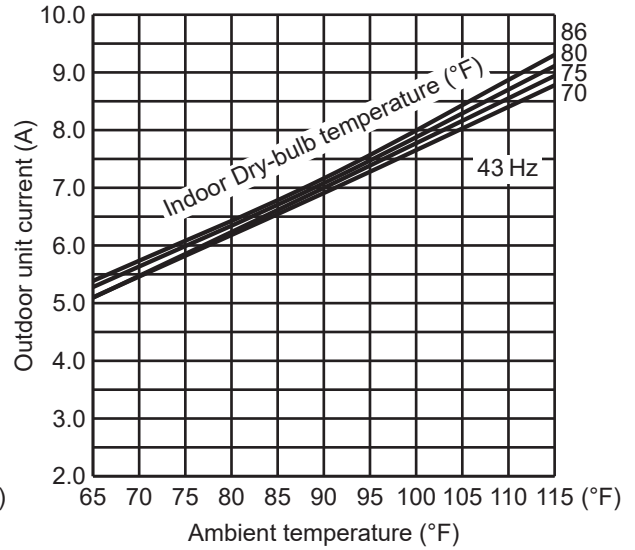
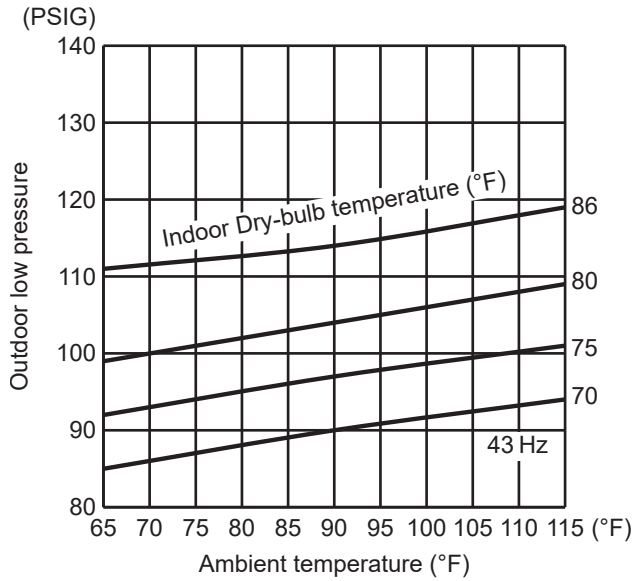

(2) HEAT operation

- ① Data is based on the condition of outdoor humidity 75%.
- ② Set air flow to High speed.
- ③ Inverter output frequency is 38 Hz.

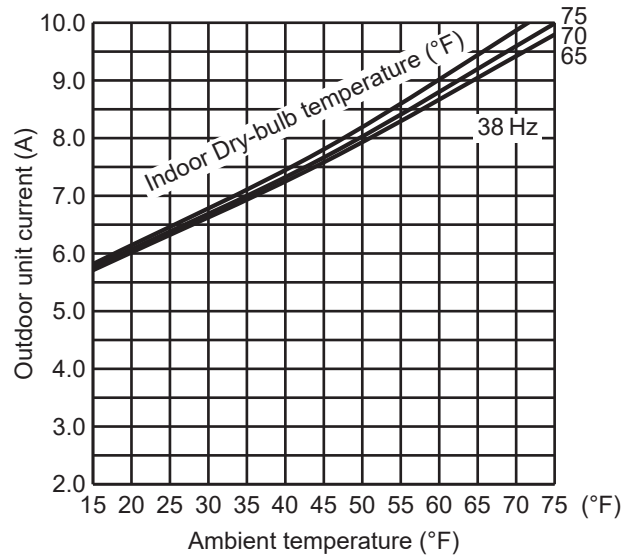

14. 15-class unit in single operation

(OUTDOOR UNIT: MXZ-5D36NL MXZ-5D42NL MXZ-3D24NLHZ MXZ-3D30NLHZ)

(1) COOL operation

- ① Data is based on the condition of indoor humidity 50%
- ② Air flow speed: High
- ③ Inverter output frequency: 43 Hz

<How to work fixed-frequency operation>

1. Set emergency switch to COOL or HEAT. The switch is located on indoor unit.
2. Press emergency run ON/OFF button.
3. Compressor starts running at 43 Hz (COOL) or 38 Hz (HEAT).
4. Indoor fan runs at High speed and continues for 30 minutes.
5. To cancel this operation, press emergency run ON/OFF button or any button on remote controller.

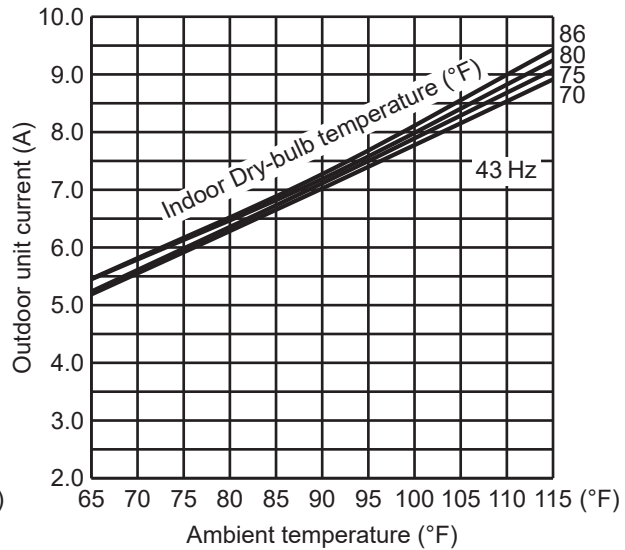
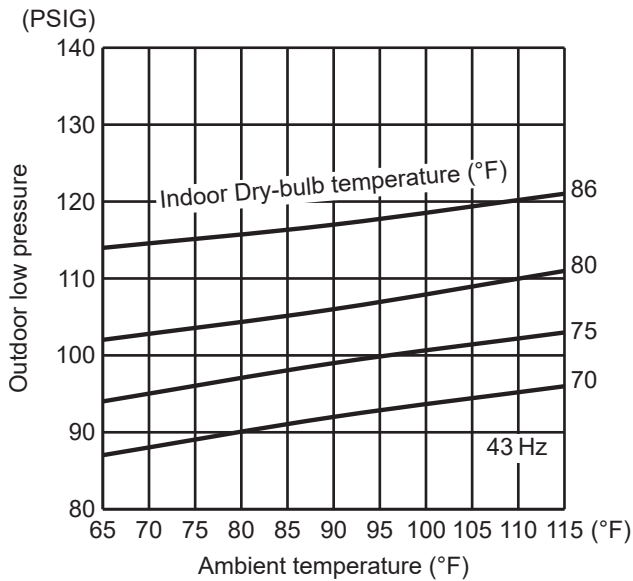

(2) HEAT operation

- ① Data is based on the condition of outdoor humidity 75%.
- ② Set air flow to High speed.
- ③ Inverter output frequency is 38 Hz.

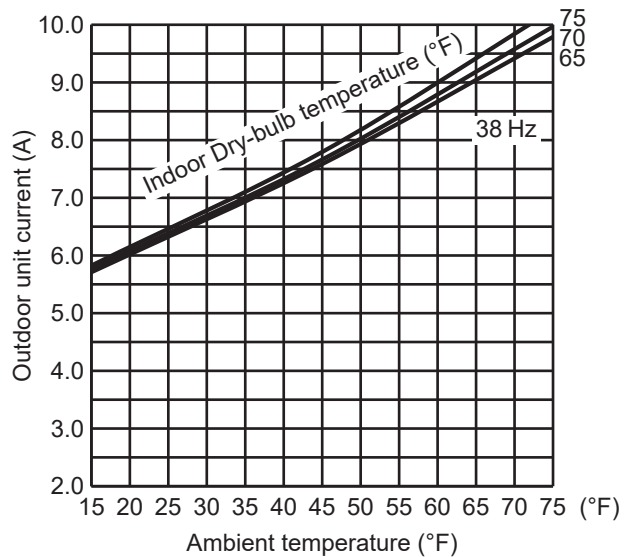

15. 18-class unit in single operation

(OUTDOOR UNIT: MXZ-5D36NL MXZ-5D42NL MXZ-3D24NLHZ MXZ-3D30NLHZ)

(1) COOL operation

- ① Data is based on the condition of indoor humidity 50%
- ② Air flow speed: High
- ③ Inverter output frequency: 43 Hz

<How to work fixed-frequency operation>

1. Set emergency switch to COOL or HEAT. The switch is located on indoor unit.
2. Press emergency run ON/OFF button.
3. Compressor starts running at 43 Hz (COOL) or 38 Hz (HEAT).
4. Indoor fan runs at High speed and continues for 30 minutes.
5. To cancel this operation, press emergency run ON/OFF button or any button on remote controller.

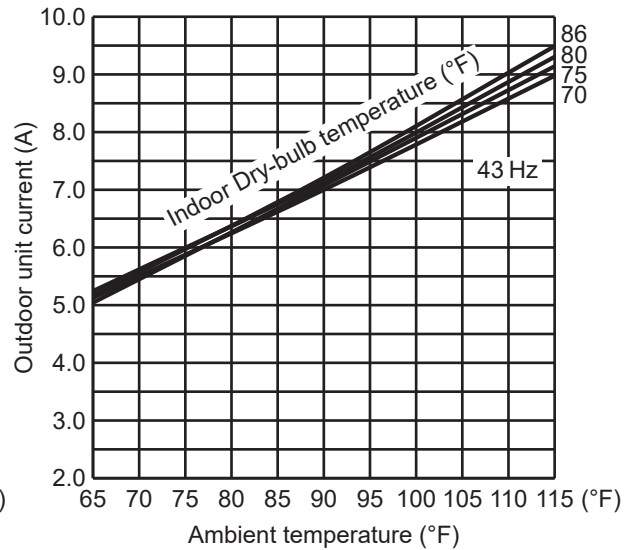
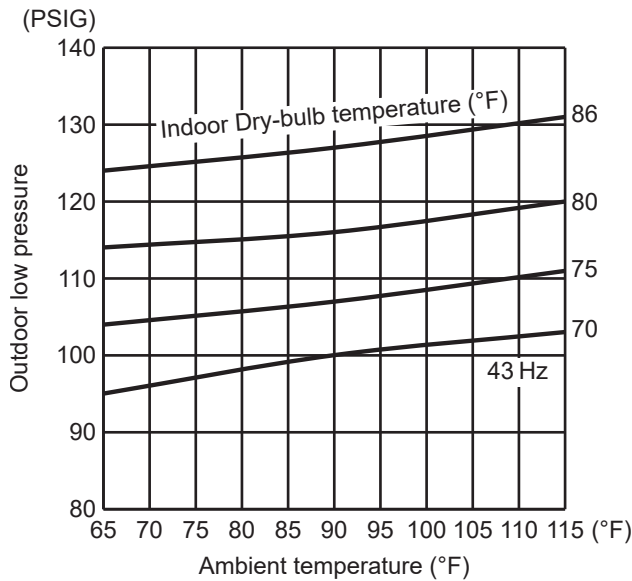

(2) HEAT operation

- ① Data is based on the condition of outdoor humidity 75%.
- ② Set air flow to High speed.
- ③ Inverter output frequency is 38 Hz.

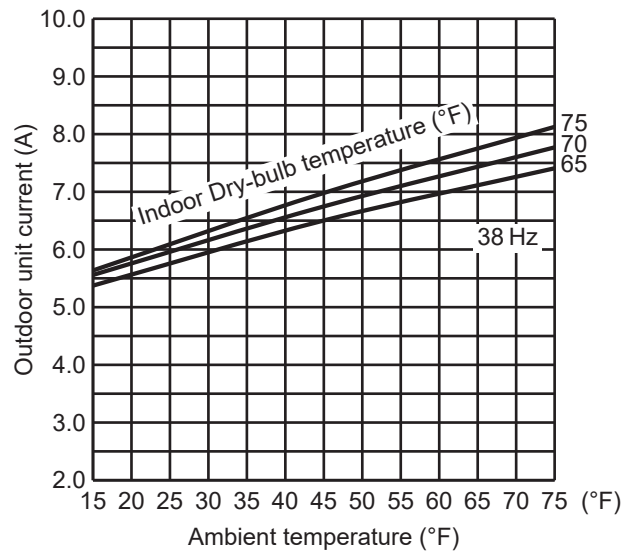

16. 24-class unit in single operation
(OUTDOOR UNIT: MXZ-5D36NL MXZ-5D42NL MXZ-3D30NLHZ)

(1) COOL operation

- ① Data is based on the condition of indoor humidity 50%
- ② Air flow speed: High
- ③ Inverter output frequency: 43 Hz

<How to work fixed-frequency operation>

1. Set emergency switch to COOL or HEAT. The switch is located on indoor unit.
2. Press emergency run ON/OFF button.
3. Compressor starts running at 43 Hz (COOL) or 38 Hz (HEAT).
4. Indoor fan runs at High speed and continues for 30 minutes.
5. To cancel this operation, press emergency run ON/OFF button or any button on remote controller.

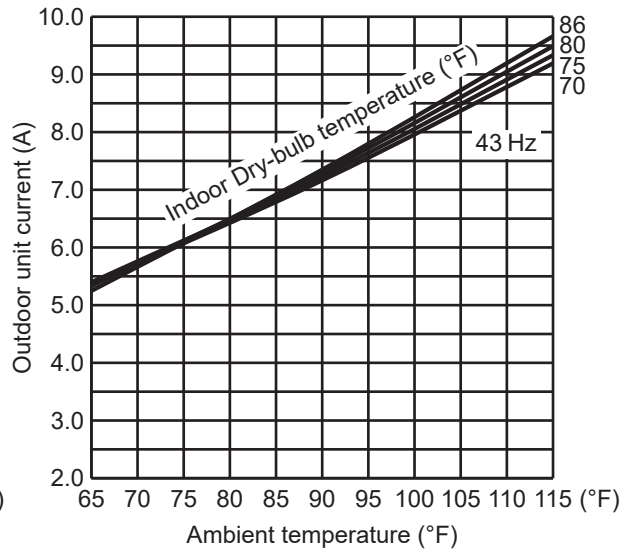
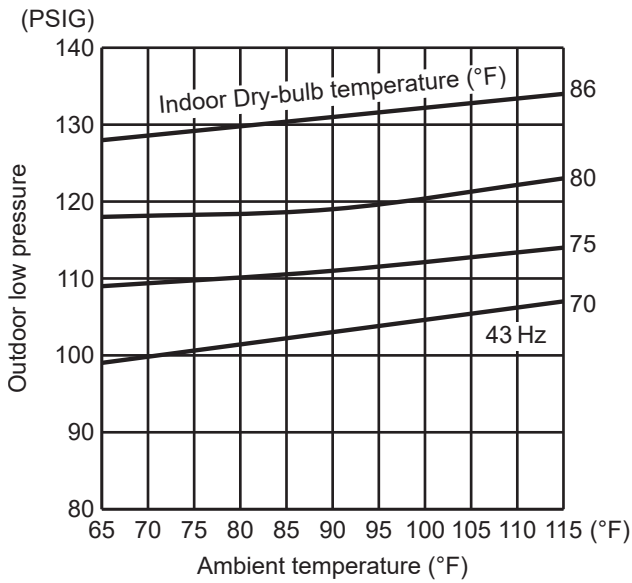

(2) HEAT operation

- ① Data is based on the condition of outdoor humidity 75%.
- ② Set air flow to High speed.
- ③ Inverter output frequency is 38 Hz.

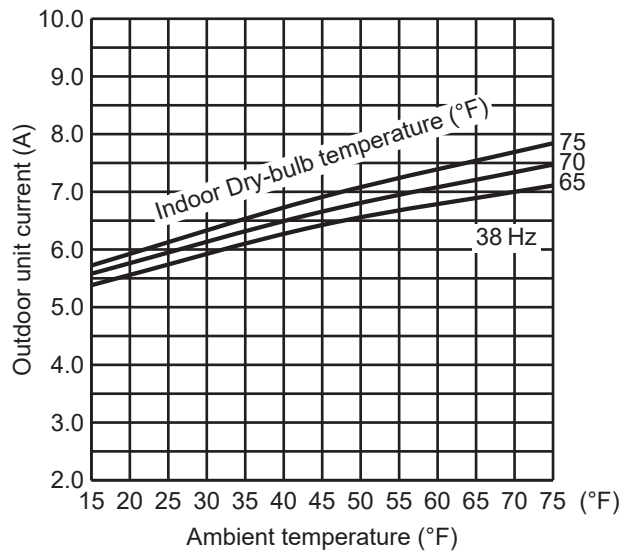

MXZ-2D20NL

MXZ-3D24NL

MXZ-4D30NL

MXZ-5D36NL

MXZ-5D42NL

MXZ-2D20NLHZ

MXZ-3D24NLHZ

MXZ-3D30NLHZ

Relation between main sensor and actuator

Sensor	Purpose	Actuator					
		Compressor	LEV	Outdoor fan motor	4-way valve	2-way solenoid valve	Defrost heater
						MXZ-5D36NL MXZ-5D42NL MXZ-3D24NLHZ MXZ-3D30NLHZ	MXZ-2D20NLHZ MXZ-3D24NLHZ MXZ-3D30NLHZ
Discharge temperature thermistor	Protection	○	○				
Indoor coil temperature thermistor	Cooling: Coil frost prevention	○				○	
	Heating: High pressure protection	○	○			○	
Defrost thermistor	Heating: Defrosting	○	○	○	○		
Fin temperature thermistor	Protection	○		○			
Ambient temperature thermistor	Control/Protection	○	○	○		○	
	Heating: Defrosting (Heater)			○			○
Outdoor heat exchanger temperature thermistor	Cooling: Control/Protection	○	○	○		○	
Capacity code	Control	○	○				

MXZ-2D20NL

MXZ-3D24NL

MXZ-4D30NL

MXZ-5D36NL

MXZ-5D42NL

MXZ-2D20NLHZ

MXZ-3D24NLHZ

MXZ-3D30NLHZ

11-1. PRE-HEAT CONTROL

If moisture gets into the refrigerant cycle, or when refrigerant is liquefied and collected in the compressor, it may interfere the startup of the compressor.

To improve start-up condition, the compressor is energized even while it is not operating.

This is to generate heat at the winding.

The compressor uses about 50 W when pre-heat control is turned ON.

Pre-heat control is ON at initial setting.

[How to deactivate pre-heat control]

- ① Turn OFF the power supply for the air conditioner before making the setting.
- ② Set the "4" of SW2 on the outdoor control P.C. board to ON to deactivate pre-heat control function.

Outdoor control P.C. board

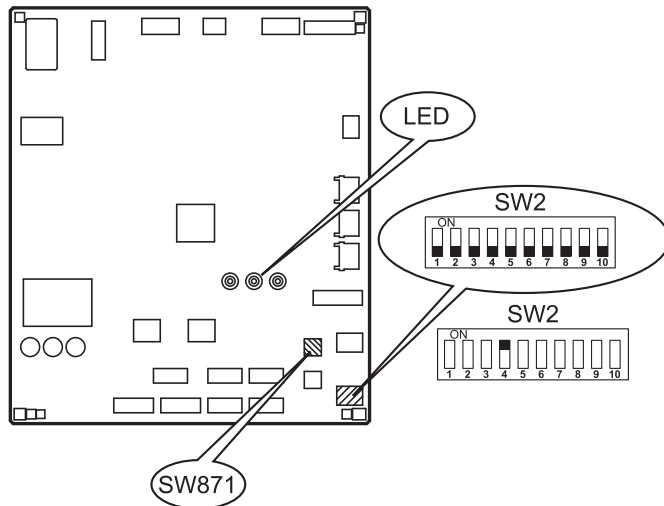

- ③ Turn ON the power supply for the air conditioner.

NOTE: Pre-heat control will be turned OFF when the breaker is turned OFF.

11-2. AUTO LINE CORRECTING

Outdoor unit has an auto line correcting function which automatically detects and corrects improper wiring or piping.

Improper wiring or piping can be automatically detected by pressing the piping/wiring correction switch (SW871). When improper wiring or piping is detected, wiring lines are corrected. This will be completed in about 10 to 20 minutes.

[How to activate this function]

1. Check that outside temperature is above 32°F.
(This function does not work when outside temperature is not above 32°F.)
2. Check that the stop valves of the liquid pipe and gas pipe are open.
3. Check that the wiring between indoor and outdoor unit is correct.
(If the wiring is not correct, this function does not work.)
4. Turn ON the power supply and wait at least 1 minute.
5. Press the piping/wiring correction switch (SW871) on the outdoor control P.C. board.
Do not touch energized parts.

LED indication during detection:

LED1 (Red)	LED2 (Yellow)	LED3 (Green)
Lit	Lit	Once

LED indication after detection:

LED1 (Red)	LED2 (Yellow)	LED3 (Green)	Indication
Lit	Not lit	Lit	Completed (Problem corrected/ normal)
Once	Once	Once	Not completed (Detection failed)
Other indications			Refer to "SAFETY PRECAUTIONS WHEN LED BLINKS" located behind the service panel.

* Make sure that the valves are open and the pipes are not collapsed or clogged.

6. Press the switch to cancel.

LED indication after cancel :

LED1 (Red)	LED2 (Yellow)	LED3 (Green)
Lit	Lit	Not lit

NOTE : Indoor unit cannot be operated while this function is activated.

When this function is activated while indoor unit is operating, the operation will be stopped.

Operate indoor unit after the auto line correcting is finished.

Pressing the switch during detection cancels this function.

The record of auto line correcting can be confirmed in the following way:

Press the switch for more than 5 seconds.

LED will show the record of auto correcting for about 30 seconds as shown in the table below:

Number of blinks			Wiring line
LED1 (Red)	LED2 (Yellow)	LED3 (Green)	
Once	Once	Lit	Not corrected
3 times	3 times	Lit	Corrected

NOTE: Activate this function to confirm the correct wiring after replacing the outdoor control P.C. board.

(Previous records are deleted when the outdoor control P.C. board is replaced.)

The record cannot be shown if auto line correcting is not canceled (Refer to "How to activate this function").

11-3. CHANGING THE SET REFRIGERANT EVAPORATING TEMPERATURE

NOTE: If you lower the refrigerant evaporating temperature with the windows open, it may cause condensation to form.

[How to change the refrigerant evaporating temperature]

- (1) Make sure there is no possibility of causing condensation to form before making the setting.
- (2) Make the setting referring to the table below.

SW2 on the outdoor control P.C. board

SW2	MXZ-2D20NL MXZ-2D20NLHZ MXZ-3D24NL MXZ-3D24NLHZ MXZ-4D30NL MXZ-3D30NLHZ MXZ-5D36NL MXZ-5D42NL
	42.8 °F (6 °C)
	Normal control (Factory setting)

11-4. Change the operation of other indoor units when miswiring or serial signal error occurs

To ensure the safety of systems that use flammable refrigerants, the system is set to operation stop if miswiring or serial signal error occurs.

This can be temporarily disabled by switching the DIP switch during service.

[Setting method]

Set the DIP switch as instructed in the table below.

SW2 on the outdoor control P.C. board

SW2	State
	If an indoor unit is incorrectly wired or has a serial signal error, other properly working units can operate.
	If an indoor unit is incorrectly wired or has a serial signal error, other properly working units stop abnormally. (UL60335 2-40)

NOTE: This mode setting is recommended when servicing for miswiring or serial signal error.

Be sure to return the DIP switch to the OFF position after servicing.

11-5. Change the LEV pulse during defrosting operation

[Setting method]

Set the DIP switch as instructed in the table below.

SW2 on the outdoor control P.C. board

SW2	State
	The LEV pulse of the indoor unit while heating operation is paused: Close
	The LEV pulse of the indoor unit while heating operation is paused: Slightly open

MXZ-2D20NL

MXZ-3D24NL

MXZ-4D30NL

MXZ-5D36NL

MXZ-5D42NL

MXZ-2D20NLHZ

MXZ-3D24NLHZ

MXZ-3D30NLHZ

12-1. CAUTIONS ON TROUBLESHOOTING**1. Before troubleshooting, check the following:**

- 1) Check the power supply voltage.
- 2) Check the indoor/outdoor connecting wire for miswiring.

2. Take care of the following during servicing.

- 1) Before servicing the air conditioner, be sure to turn OFF the unit first with the remote controller, and then after confirming the horizontal vane is closed, turn OFF the breaker and/or disconnect the power plug.
- 2) Be sure to turn OFF the power supply before removing the front panel, the cabinet, the top panel, and the outdoor control P.C. board.
- 3) When removing the electrical parts, be careful of the residual voltage of smoothing capacitor.
- 4) When removing the electronic control P.C. board, hold the edge of the board with care NOT to apply stress on the components.
- 5) When connecting or disconnecting the connectors, hold the connector housing. DO NOT pull the lead wires.

<Incorrect>

**Lead wiring**

<Correct>

**Connector housing****3. Troubleshooting procedure**

- 1) Check if the OPERATION INDICATOR lamp on the indoor unit is blinking on and off to indicate an abnormality. To make sure, check how many times the OPERATIONAL INDICATOR lamp is blinking on and off before starting service work.
- 2) When the outdoor control P.C. board seems to be defective, check for disconnection of the copper foil pattern and burnt or discolored components.
- 3) When troubleshooting, refer to 12-2, 12-3 and 12-4.

12-2. FAILURE MODE RECALL FUNCTION

This air conditioner can memorize the abnormal condition which has occurred once.

Even though LED indication listed on the troubleshooting check table (12-4) disappears, the memorized failure details can be recalled.

1. Flow chart of failure mode recall function for the indoor/outdoor unit

Refer to the service manual of indoor unit.

2. Flow chart of the detailed outdoor unit failure mode recall function

Operational procedure

The outdoor unit might be abnormal.
Check if outdoor unit is abnormal according to the following procedures.

Make sure that the remote controller is set to the failure mode recall function.
*3

With the remote controller headed towards the indoor unit, press the TEMPERATURE buttons to adjust the set temperature to 77°F (25°C). *1

Does the OPERATION INDICATOR lamp on the indoor unit blink at the interval of 0.5 seconds?
Blinks: The outdoor unit is abnormal. Beep is emitted at the same timing as the blinking of the OPERATION INDICATOR lamp. *2

*1 Regardless of normal or abnormal condition, 2 short beeps are emitted as the signal is received.

*3 Refer to the service manual of indoor unit.

The outdoor unit is abnormal.
Check the blinking pattern, and identify the abnormal point by referring to the table of outdoor unit failure mode recall function (12-2.3).
Make sure to check at least 2 consecutive blinking cycles. *2

The outdoor unit is normal.

Release the failure mode recall function. *3

Release the failure mode recall function. *3

Repair the failure parts.

Delete the memorized abnormal condition. *3

Release the failure mode recall function. *3

NOTE: 1. Make sure to release the failure mode recall function after it is set up, otherwise the unit cannot operate properly.
2. If the abnormal condition is not deleted from the memory, the last abnormal condition is kept memorized.

*2. Blinking pattern when outdoor unit is abnormal:

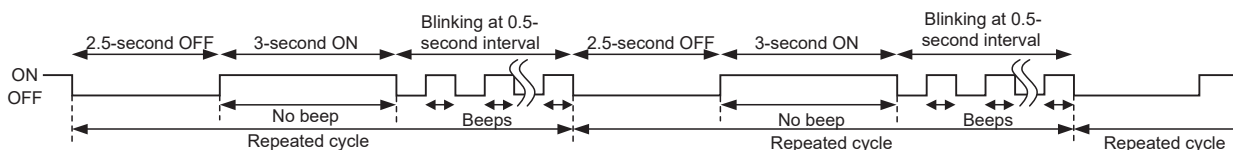

NOTE: Blinking patterns of this mode differ from the ones of TROUBLESHOOTING CHECK TABLE (12-4.).

3. Table of outdoor unit failure mode recall function

The left lamp of OPERATION INDICATOR lamp (Indoor unit)	Abnormal point (Failure mode/protection)	LED indication (Outdoor P.C. board)		Condition	Remedy	Indoor/outdoor unit failure mode recall function
		LED 1	LED 2			
OFF	None (Normal)	Lit	Lit	—	—	—
2-time blink	Outdoor power system	Lit	Lit	Overcurrent protection cut-out operates 3 consecutive times within 1 minute after the compressor gets started, or converter protection cut-out or bus-bar voltage protection cut-out operates 3 consecutive times within 3 minutes after startup.	<ul style="list-style-type: none"> • Check the connection of the compressor connecting wire. • Refer to 12-6. ⑥ “How to check inverter/compressor”. • Check the stop valve. 	○
3-time blink	Discharge temperature thermistor	Lit	Once	A thermistor shorts or opens during compressor running.	<ul style="list-style-type: none"> • Refer to 12-6. ⑥ “Check of outdoor thermistors”. 	○
	Defrost thermistor	Lit	Once			
	Ambient temperature thermistor	Lit	Twice			
	Fin temperature thermistor	Lit	3 times			
	P.C. board temperature thermistor	Lit	4 times			
	Outdoor heat exchanger temperature thermistor	Lit	9 times			
4-time blink	Overcurrent	Once	Not lit	18 A (MXZ-2D20NL)/22 A (MXZ-3D24/4D30NL, MXZ-2D20NLHZ)/35 A (MXZ-5D36/42NL, MXZ-3D24/3D30NLHZ) current flows into power module.	<ul style="list-style-type: none"> • Reconnect compressor connector. • Refer to 12-6. ⑥ “How to check inverter/compressor”. • Check the stop valve. 	—
5-time blink	Discharge temperature	Lit	Lit	The discharge temperature exceeds 239°F (MXZ-2D20NL)/222.8°F (MXZ-3D24/4D30NL, MXZ-2D20NLHZ)/230°F (MXZ-5D36/42NL, MXZ-3D24/30NLHZ) during operation. Compressor can restart if discharge temperature thermistor reads 176°F (MXZ-2D20NL)/203°F (MXZ-3D24/4D30/5D36/42NL, MXZ-2D20/3D24/30NLHZ) or less 3 minutes later.	<ul style="list-style-type: none"> • Check refrigerant circuit and refrigerant amount. • Refer to 12-6. ⑥ “Check of LEV”. 	—
6-time blink	High pressure	Lit	Lit	The outdoor heat exchanger temperature exceeds 158°F during cooling or the indoor gas pipe temperature exceeds 158°F during heating.	<ul style="list-style-type: none"> • Check refrigerant circuit and refrigerant amount. • Check the stop valve. 	—
7-time blink	Fin temperature	3 times	Not lit	The fin temperature exceeds 176°F (MXZ-2D20NL)/192°F (MXZ-3D24/4D30NL, MXZ-2D20NLHZ)/190°F (MXZ-5D36/42NL, MXZ-3D24/30NLHZ) during operation.	<ul style="list-style-type: none"> • Check around outdoor unit. • Check outdoor unit air passage. • Refer to 12-6. ⑥ “Check of outdoor fan motor”. 	—
	P.C. board temperature	4 times	Not lit	The P.C. board temperature exceeds 152°F (MXZ-2D20NL)/189°F (MXZ-3D24/4D30NL, 2D20NLHZ)/150°F (MXZ-5D36/42NL, MXZ-3D24/30NLHZ) during operation.		
8-time blink	Outdoor fan motor	Lit	Lit	A failure occurs 3 consecutive times within 30 seconds after the fan gets started.	<ul style="list-style-type: none"> • Refer to 12-6. ⑥ “Check of outdoor fan motor”. • Refer to 12-6. ⑥ “Check of R.V. coil”. • Check the 4-way valve. 	○
	4-way valve switching operation abnormality.	Lit	12 times	Connector of R.V. coil is disconnected, poorly connected or 4-way valve is faulty.		
9-time blink	Outdoor control system	Lit	5 times	Nonvolatile memory data cannot be read properly.	<ul style="list-style-type: none"> • Replace the outdoor control P.C. board. 	○
10-time blink	Low discharge temperature protection	Lit	Lit	The frequency of the compressor is kept 80 Hz or more and the discharge temperature is kept under 102.2°F for more than 20 minutes.	<ul style="list-style-type: none"> • Check refrigerant circuit and refrigerant amount. • Refer to 12-6. ⑥ “Check of LEV”. 	—

NOTE: Blinking patterns of this mode differ from the ones of TROUBLESHOOTING CHECK TABLE (12-4.).

The left lamp of OPERATION INDICATOR lamp (Indoor unit)	Abnormal point (Failure mode/protection)	LED indication (Outdoor P.C. board)		Condition	Remedy	Indoor/outdoor unit failure mode recall function
		LED 1	LED 2			
11-time blink	Communication error between P.C. boards	Lit	6 times	Communication error occurs between the outdoor control P.C. board and outdoor power P.C. board for more than 10 seconds.	<ul style="list-style-type: none"> • Check the connecting wire between outdoor control P.C. board and outdoor power P.C. board. 	—
				The communication between boards protection cut-out operates 2 consecutive times.		○
	Current sensor	Lit	7 times	A short or open circuit is detected in the current sensor during compressor operating.	—	—
				Current sensor protection cut-out operates 2 consecutive times.		○
	Zero cross detecting circuit	5 times	Not lit	Zero cross signal cannot be detected while the compressor is operating.	<ul style="list-style-type: none"> • Check the connecting wire among outdoor control P.C. board and outdoor power P.C. board. 	—
				The protection cut-out of the zero cross detecting circuit operates 10 consecutive times.		○
Converter	5 times	Not lit	A failure is detected in the operation of the converter during operation.	<ul style="list-style-type: none"> • Check the voltage of power supply. • Replace the outdoor power P.C. board. 	—	
Bus-bar voltage	5 times	Not lit	The bus-bar voltage exceeds 430 V or falls to low level during compressor operating.	<ul style="list-style-type: none"> • Check the voltage of power supply. • Replace the outdoor power P.C. board or the outdoor control P.C. board. 		
14-time blink	Refrigerant leakage (Sensor detection)	Lit	Lit	1. Refrigerant leaks from the piping or the heat exchanger in the indoor unit. 2. The following items are used around the indoor unit. <ul style="list-style-type: none"> • Spray (LP gas including Freon, and whose main ingredient is propane and butane) • Aerosol insecticide (including ethanol) • Air spray painting (including dichloromethane) • Charcoal (charcoal fire) • Chemicals (such as ethanol) 	<ul style="list-style-type: none"> • Turn off the power after the indoor unit finishes its FAN operation. (The FAN operation continues for 3 hours.) • Check the indoor unit to detect the part where refrigerant leaks. • Repair the part where refrigerant leaks. • Turn on the power again. • Replace the refrigerant sensor if the problem is not fixed. 	○
	Refrigerant leakage (Sensor detection)	Lit	Lit	The refrigerant sensor mounted on the indoor unit does not work. The refrigerant sensor is not connected properly or the wire is broken.	<ul style="list-style-type: none"> • Connect the connector of the refrigerant sensor properly. • Replace the refrigerant sensor. 	○
	Incompatible unit combination	Lit	11 times	The indoor unit which is not compatible with the outdoor unit is connected.	<ul style="list-style-type: none"> • Replace the indoor unit with the one which is compatible with the outdoor unit. 	○
	4-way valve switching operation abnormality.	Lit	12 times	Connector of R.V. coil is disconnected, poorly connected or 4-way valve is faulty.	<ul style="list-style-type: none"> • Refer to 12-6. © "Check of R.V. coil". • Check the 4-way valve. 	○
	Indoor/outdoor unit communication error	Lit	14 times	The communication fails between the indoor and outdoor unit.	<ul style="list-style-type: none"> • Refer to 12-6. ® "How to check miswiring and serial signal error (when outdoor unit does not work)". 	○
15-time blink	LEV and drain pump	Lit	Lit	The indoor unit detects an abnormality in the LEV and drain pump.	<ul style="list-style-type: none"> • Refer to 12-6. Ⓓ "Check of LEV". • Check the drain pump of the indoor unit. 	—

12-3. INSTRUCTIONS FOR TROUBLESHOOTING

- Check the indoor unit while referring to the indoor unit service manual, and confirm if there is any problem in the indoor unit. Then, check the outdoor unit while referring to this page.

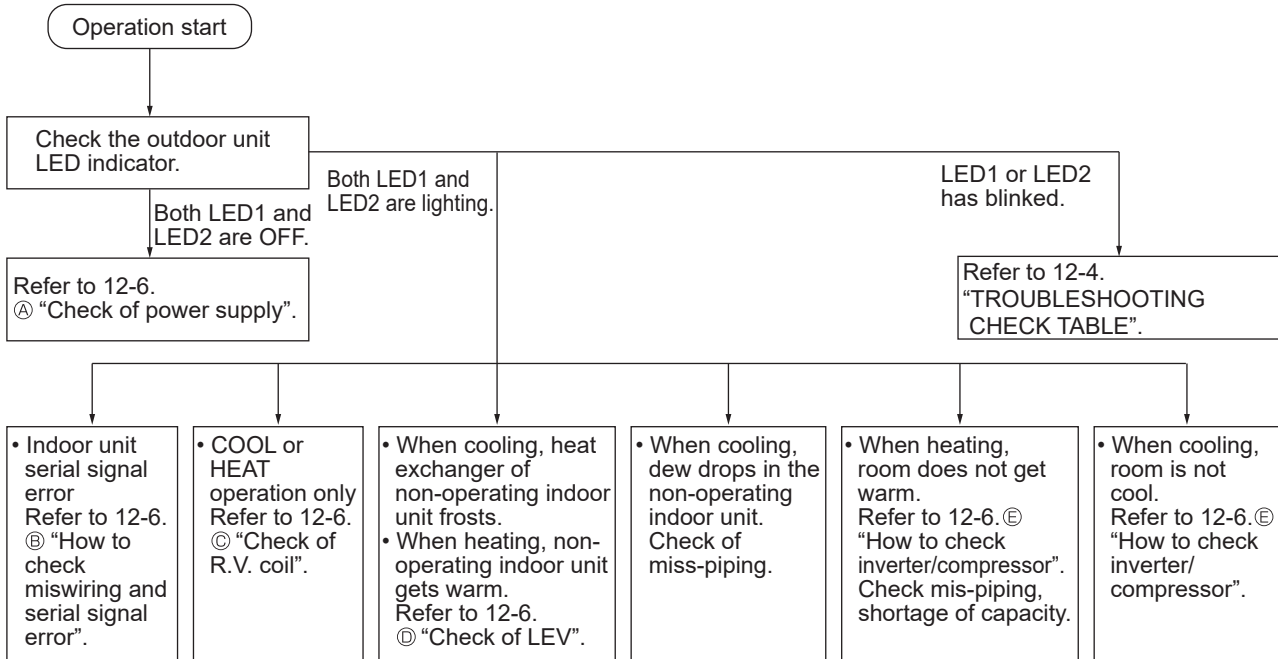

12-4. TROUBLESHOOTING CHECK TABLE

No.	Symptom	Indication		Abnormal point / Condition	Condition	Remedy
		LED1(Red)	LED2(Yellow)			
1	Outdoor unit does not operate.	Lit	Once	LEV and drain pump	The indoor unit detects an abnormality in the LEV and drain pump.	<ul style="list-style-type: none"> Refer to 12-6. ④ "Check of LEV". Check the drain pump of the indoor unit.
2		Lit	Twice	Outdoor power system	Overcurrent protection cut-out operates 3 consecutive times within 1 minute after the compressor gets started, or converter protection cut-out or bus-bar voltage protection cut-out operates 3 consecutive times within 3 minutes after startup.	<ul style="list-style-type: none"> Check the connection of the compressor connecting wire. Refer to 12-6. ④ "How to check inverter/compressor". Check the stop valve.
3		Lit	3 times	Discharge temperature thermistor	A short circuit is detected in the thermistor during operation, or an open circuit is detected in the thermistor after 10 minutes of compressor startup.	<ul style="list-style-type: none"> Refer to 12-6. ④ "Check of outdoor thermistors".
4		Lit	4 times	Fin temperature thermistor P. C. board temperature thermistor	A short or open circuit is detected in the thermistor during operation.	<ul style="list-style-type: none"> Refer to 12-6. ④ "Check of outdoor thermistors".
						<ul style="list-style-type: none"> Replace the outdoor control P.C. board.
5		Lit	5 times	Ambient temperature thermistor Outdoor heat exchanger temperature thermistor Defrost thermistor	A short or open circuit is detected in the thermistor during operation. A short circuit is detected in the thermistor during operation, or an open circuit is detected in the thermistor after 5 minutes (in cooling) and 10 minutes (in heating) of compressor startup. A short circuit is detected in the thermistor during operation, or an open circuit is detected in the thermistor after 5 minutes of compressor startup.	<ul style="list-style-type: none"> Refer to 12-6. ④ "Check of outdoor thermistors".
6		Lit	7 times	Outdoor control system	The nonvolatile memory data cannot be read properly.	<ul style="list-style-type: none"> Replace the outdoor control P.C. board.
7		Lit	8 times	Current sensor	Current sensor protection cut-out operates 2 consecutive times.	<ul style="list-style-type: none"> Replace the outdoor power P.C. board.
8		Lit	11 times	Communication error between P.C. boards M-NET communication error	The communication protection cut-out between boards operates 2 consecutive times. M-NET adapter P.C. board detects an abnormality in the communication error.	<ul style="list-style-type: none"> Check the connecting wire between outdoor control P.C. board and outdoor power P.C. board. Check the connecting wire between M-NET adapter P.C. board and outdoor control P.C. board, or terminal bed.
9		Lit	12 times	Zero cross detecting circuit (Outdoor power P.C. board)	The protection cut-out of the zero cross detecting circuit operates 10 consecutive times.	<ul style="list-style-type: none"> Replace the outdoor power P.C. board.
10		Lit	13 times	Current sensor	A short or open circuit is detected in the input current detection circuit during operation.	<ul style="list-style-type: none"> Replace the outdoor power P.C. board.
11		Lit	14 times	Voltage sensor	A short or open circuit is detected in the input voltage detection circuit during operation.	<ul style="list-style-type: none"> Replace the outdoor power P.C. board.
12		Lit	15 times	Relay operation	No relay operation is detected during operation.	<ul style="list-style-type: none"> Replace the outdoor power P.C. board.
13		Lit	18 times	Detection of refrigerant (Indoor unit)	1. Refrigerant leaks from the piping or the heat exchanger in the indoor unit. 2. The following items are used around the indoor unit. <ul style="list-style-type: none"> Spray (LP gas including Freon, and whose main ingredient is propane and butane) Aerosol insecticide (including ethanol) Air spray painting (including dichloromethane) Charcoal (charcoal fire) Chemicals (such as ethanol) 	<ul style="list-style-type: none"> Turn off the power after the indoor unit finishes its fan operation. (The fan operation continues for 3 hours.) Check the indoor unit to detect the part where refrigerant leaks. Repair the part where refrigerant leaks. Turn on the power again. Replace the refrigerant sensor if the problem is not fixed.
14		Lit	19 times	Abnormality of refrigerant leakage sensor (Indoor unit)	The refrigerant sensor mounted on the indoor unit does not work. The refrigerant sensor is not connected properly or the wire is broken.	<ul style="list-style-type: none"> Connect the connector of the refrigerant sensor properly. Replace the refrigerant sensor.
15		Lit	20 times	Incompatible unit combination error	The indoor unit which is not compatible with the outdoor unit is connected.	<ul style="list-style-type: none"> Replace the indoor unit with the one which is compatible with the outdoor unit.
16		Lit	21 times	4-way valve	Connector of R.V. coil is disconnected, poorly connected or 4-way valve is faulty.	<ul style="list-style-type: none"> Refer to 12-6. ④ "Check of R.V. coil". Check the 4-way valve.
17	Lit	24 times	Serial signal	The communication fails between the indoor and outdoor unit.	<ul style="list-style-type: none"> Refer to 12-6. ④ "How to check miswiring and serial signal error (when outdoor unit does not work)". 	

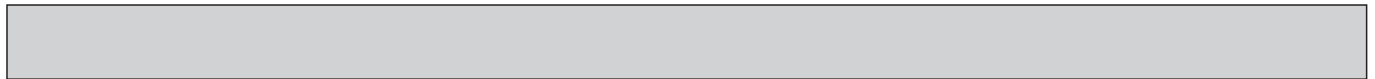

No.	Symptom	Indication		Abnormal point / Condition	Condition	Remedy
		LED1(Red)	LED2(Yellow)			
18	'Outdoor unit stops and restarts 3 minutes later' is repeated.	Twice	Not lit	IPM protection	Overcurrent is detected after 30 seconds of compressor startup.	<ul style="list-style-type: none"> • Reconnect compressor connector. • Refer to 12-6. Ⓔ "How to check inverter/compressor". • Check the stop valve. • Check the power module (PAM module).
				Lock protection	Overcurrent is detected within 30 seconds of compressor startup.	
19		3 times	Not lit	Discharge temperature protection	The discharge temperature exceeds 239°F (MXZ-2D20NL)/222.8°F (MXZ-3D24/4D30NL, MXZ-2D20NLHZ)/230°F (MXZ-5D36/42NL, MXZ-3D24/30NLHZ) during operation. Compressor can restart if discharge temperature thermistor reads 176°F (MXZ-2D20NL)/203°F (MXZ-3D24/4D30/5D36/42NL, MXZ-2D20/3D24/30NLHZ) or less 3 minutes later.	<ul style="list-style-type: none"> • Check the amount of gas and refrigerant circuit. • Refer to 12-6. Ⓒ "Check of LEV".
Fin temperature protection				The fin temperature exceeds during operation.	<ul style="list-style-type: none"> • Check refrigerant circuit and refrigerant amount. • Refer to 12-6. Ⓒ "Check of outdoor fan motor". 	
20				4 times	Not lit	
21	5 times	Not lit		The outdoor heat exchanger temperature exceeds 158°F during cooling or the indoor gas pipe temperature exceeds 158°F during heating.		
22	6 times	Not lit	Pre-heating protection	Overcurrent is detected during pre-heating.	<ul style="list-style-type: none"> • Reconnect compressor connector. • Refer to 12-6. Ⓔ "How to check inverter/compressor". • Check the power module. 	
23	8 times	Not lit	Converter protection	A failure is detected in the operation of the converter during operation.	• Replace the outdoor power P.C. board.	
24	9 times	Not lit	Bus-bar voltage protection	The bus-bar voltage exceeds 400 V or falls to low level during compressor operating.	<ul style="list-style-type: none"> • Check the voltage of power supply. • Replace the outdoor power P.C. board or the outdoor control P.C. board. • Refer to 12-6. Ⓓ "Check of bus-bar voltage". 	
25	11 times	Not lit	Low out side temperature protection(cooling)	The ambient became 10.4°F or less.	—	
			Low out side temperature protection(Heating)	The ambient became -4.2°F or less. (MXZ-2D20/3D24/4D30/5D36/42NL)		
				The ambient became -18°F or less. (MXZ-2D20/3D24/3D30NLHZ)		
26	13 times	Not lit	Outdoor fan motor	A failure occurs 3 consecutive times within 30 seconds after the fan gets started.	• Refer to 12-6. Ⓒ "Check of outdoor fan motor".	
27	14 times	Not lit	4-way valve switching operation	Connector of R.V. coil is disconnected, poorly connected or 4-way valve is faulty.	<ul style="list-style-type: none"> • Refer to 12-6. Ⓒ "Check of R.V. coil". • Check the 4-way valve. 	
28	Lit	8 times	Current sensor protection	A short or open circuit is detected in the current sensor during compressor operating.	• Replace the outdoor power P.C. board.	
29	Lit	11 times	Communication between P.C. boards protection	Communication error occurs between the outdoor control P.C. board and outdoor power P.C. board for more than 10 seconds.	• Check the connecting wire between outdoor control P.C. board and outdoor power P.C. board.	
30	Lit	12 times	Zero cross detecting circuit protection (Outdoor power P.C. board)	Zero cross signal cannot be detected while the compressor is operating.	• Replace the outdoor power P.C. board.	
31	Outdoor unit operates.	Once	Lit	Primary current protection	The input current exceeds 14.4 A (MXZ-2D20NL)/ 18.6 A (MXZ-3D24/4D30NL, MXZ-2D20NLHZ)/ 26.8 A (MXZ-5D36/42NL, MXZ-3D24/3D30NLHZ).	<ul style="list-style-type: none"> • These symptoms do not mean any abnormality of the product, but check the following points. • Check if indoor filters are clogged. • Check if refrigerant is short. • Check if indoor/outdoor unit air circulation is short cycled.
Twice		Lit	High pressure protection	The indoor gas pipe temperature exceeds 113°F during heating.		
			Defrosting in cooling	The indoor gas pipe temperature falls 37.4°F or below during cooling.		
33	3 times	Lit	Discharge temperature protection	The frequency of the compressor is kept 80 Hz or more and the discharge temperature is kept under 122°F(COOL mode)/104°F(HEAT mode) for more than 40 minutes.	<ul style="list-style-type: none"> • Check refrigerant circuit and refrigerant amount. • Refer to 12-6. Ⓒ "Check of LEV". • Refer to 12-6. Ⓔ "Check of outdoor thermistors". 	

No.	Symptom	Indication		Abnormal point / Condition	Condition	Remedy
		LED1(Red)	LED2(Yellow)			
34	Outdoor unit operates.	4 times	Lit	Low discharge temperature protection	The frequency of the compressor is kept 80 Hz or more and the discharge temperature is kept under 122°F(COOL mode)/104°F(HEAT mode) for more than 20 minutes.	<ul style="list-style-type: none"> Refer to 12-6. © "Check of LEV". Check refrigerant circuit and refrigerant amount.
35		5 times	Lit	Cooling high pressure protection	The outdoor heat exchanger temperature exceeds 129°F during operation.	<p>This symptom does not mean any abnormality of the product, but check the following points.</p> <ul style="list-style-type: none"> Check if indoor filters are clogged. Check if refrigerant is short. Check if indoor/outdoor unit air circulation is short cycled.
36		7 times	Lit	High → Low Pressure bypass valve Cooling evaporating temperature drop prevention control	<p>During cooling operation, the temperature of indoor heat exchanger becomes 37.4°F or less within 1 hour after the compressor starts running, or it becomes less than 53.6°F - 60.8°F* later than that.</p> <p>* It depends on the difference between the set temperature and the room temperature. (MXZ-2D20/3D24/3D30NLHZ, MXZ-5D42NL)</p>	<p>This symptom does not mean any abnormality of the product, but check the following points.</p> <ul style="list-style-type: none"> Check the indoor filters are not clogged. Check there is sufficient refrigerant. Check the indoor/outdoor unit air circulation is not short cycled.
37		11 times	Lit	M-NET communication error	M-NET adapter P.C. board detects an abnormality in the communication error.	<ul style="list-style-type: none"> Check the connecting wire between M-NET adapter P.C. board and outdoor control P.C. board, or terminal block.
38	Outdoor unit operates normally.	7 times	Lit	High → Low pressure bypass valve High pressure protection control at startup of heating operation	The room temperature is 75.2°F or more when 1 or 2 unit(s) start(s) the heating operation. (MXZ-3D24/30NLHZ, MXZ-5D36/42NL)	<p>This symptom does not mean any abnormality of the product.</p>
High → Low pressure bypass valve Compressor oil tempering control at startup of heating operation				<p>Both the following are true:</p> <ul style="list-style-type: none"> The outside temperature is 28.4°F or less when the heating operation is started. [(Discharge temperature) - (Indoor heat exchanger temperature)] < 9°F (MXZ-3D24/30NLHZ, MXZ-5D36/42NL) 		
39		8 times	Lit	Cooling evaporating temperature protection	<p>During cooling operation, the temperature of indoor heat exchanger becomes 44.6°F - 51.8°F* or less within 1 hour after the compressor starts running, or it becomes 48.2°F - 62.6°F* or less later than that.</p> <p>* It depends on the indoor unit type/model or the difference between the set temperature and the room temperature.</p>	
40	9 times	Lit	Inverter check mode	The unit is operated with emergency operation switch.	—	
41	Lit	Lit	Normal	—	—	

NOTE: 1. The location of LED is illustrated at the right figure. Refer to 12-7.1.

2. LED is lit during normal operation.

The blinking frequency shows the number of times the LED blinks after every 2.5-second OFF.

(Example) When the blinking frequency is "2".

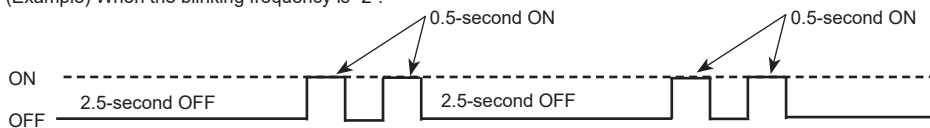

Outdoor control P.C. board
(Parts side)

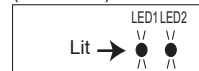

12-5. TROUBLESHOOTING CRITERION OF MAIN PARTS

MXZ-2D20NL

MXZ-3D24NL

MXZ-4D30NL

MXZ-5D36NL

MXZ-5D42NL

MXZ-2D20NLHZ

MXZ-3D24NLHZ

MXZ-3D30NLHZ

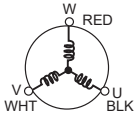
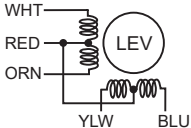
Part name	Check method and criterion												
Defrost thermistor (RT61) Fin temperature thermistor (RT64) Ambient temperature thermistor (RT65) Outdoor heat exchanger temperature thermistor (RT68)	Measure the resistance with a multimeter. Refer to 12-7. "TEST POINT DIAGRAM AND VOLTAGE", 1. "Outdoor control P.C.board", 2. "Outdoor power P.C. board", for the chart of thermistor.												
Discharge temperature thermistor (RT62)	Measure the resistance with a multimeter. Before measurement, hold the thermistor with your hands to warm it up. Refer to 12-7. "TEST POINT DIAGRAM AND VOLTAGE", 1. "Outdoor control P.C. board" for the chart of thermistor.												
Compressor 	Measure the resistance between terminals using a multimeter. (Winding temperature: 14°F - 104°F) <table border="1" style="width: 100%; text-align: center;"> <thead> <tr> <th colspan="3">Normal (Each phase)</th> </tr> <tr> <th>MXZ-2D20NL</th> <th>MXZ-3D24NL MXZ-4D30NL MXZ-2D20NLHZ</th> <th>MXZ-5D36NL MXZ-5D42NL MXZ-3D24NLHZ MXZ-3D30NLHZ</th> </tr> </thead> <tbody> <tr> <td>1.37 Ω - 1.69 Ω</td> <td>0.64 Ω - 0.78 Ω</td> <td>0.31 Ω - 0.38 Ω</td> </tr> </tbody> </table>	Normal (Each phase)			MXZ-2D20NL	MXZ-3D24NL MXZ-4D30NL MXZ-2D20NLHZ	MXZ-5D36NL MXZ-5D42NL MXZ-3D24NLHZ MXZ-3D30NLHZ	1.37 Ω - 1.69 Ω	0.64 Ω - 0.78 Ω	0.31 Ω - 0.38 Ω			
Normal (Each phase)													
MXZ-2D20NL	MXZ-3D24NL MXZ-4D30NL MXZ-2D20NLHZ	MXZ-5D36NL MXZ-5D42NL MXZ-3D24NLHZ MXZ-3D30NLHZ											
1.37 Ω - 1.69 Ω	0.64 Ω - 0.78 Ω	0.31 Ω - 0.38 Ω											
Outdoor fan motor	• Refer to 12-6. ©												
R.V. coil	Measure the resistance using a multimeter. (Part temperature: 14°F - 104°F) <table border="1" style="width: 100%; text-align: center;"> <thead> <tr> <th colspan="3">Normal (Each phase)</th> </tr> <tr> <th>MXZ-2D20NL</th> <th>MXZ-3D24NL MXZ-4D30NL MXZ-2D20NLHZ</th> <th>MXZ-5D36NL MXZ-5D42NL MXZ-3D24NLHZ MXZ-3D30NLHZ</th> </tr> </thead> <tbody> <tr> <td>1.26 kΩ - 1.62 kΩ</td> <td colspan="2">1.20 kΩ - 1.77 kΩ</td> </tr> </tbody> </table>	Normal (Each phase)			MXZ-2D20NL	MXZ-3D24NL MXZ-4D30NL MXZ-2D20NLHZ	MXZ-5D36NL MXZ-5D42NL MXZ-3D24NLHZ MXZ-3D30NLHZ	1.26 kΩ - 1.62 kΩ	1.20 kΩ - 1.77 kΩ				
Normal (Each phase)													
MXZ-2D20NL	MXZ-3D24NL MXZ-4D30NL MXZ-2D20NLHZ	MXZ-5D36NL MXZ-5D42NL MXZ-3D24NLHZ MXZ-3D30NLHZ											
1.26 kΩ - 1.62 kΩ	1.20 kΩ - 1.77 kΩ												
2-way valve solenoid coil	Measure the resistance using a multimeter. (Part temperature: 14°F - 104°F) <table border="1" style="width: 100%; text-align: center;"> <thead> <tr> <th colspan="4">Normal</th> </tr> <tr> <th>MXZ-5D36NL</th> <th>MXZ-5D42NL</th> <th>MXZ-3D24NLHZ</th> <th>MXZ-3D30NLHZ</th> </tr> </thead> <tbody> <tr> <td colspan="4">0.97 kΩ - 1.37 kΩ</td> </tr> </tbody> </table>	Normal				MXZ-5D36NL	MXZ-5D42NL	MXZ-3D24NLHZ	MXZ-3D30NLHZ	0.97 kΩ - 1.37 kΩ			
Normal													
MXZ-5D36NL	MXZ-5D42NL	MXZ-3D24NLHZ	MXZ-3D30NLHZ										
0.97 kΩ - 1.37 kΩ													
Linear expansion valve 	Measure the resistance using a multimeter. (Part temperature: 14°F - 104°F) <table border="1" style="width: 100%; text-align: center;"> <thead> <tr> <th>Color of lead wire</th> <th>Normal</th> </tr> </thead> <tbody> <tr> <td>WHT - RED</td> <td rowspan="4">37.4 Ω - 53.9 Ω</td> </tr> <tr> <td>RED - ORN</td> </tr> <tr> <td>YLW - RED</td> </tr> <tr> <td>RED - BLU</td> </tr> </tbody> </table>	Color of lead wire	Normal	WHT - RED	37.4 Ω - 53.9 Ω	RED - ORN	YLW - RED	RED - BLU					
Color of lead wire	Normal												
WHT - RED	37.4 Ω - 53.9 Ω												
RED - ORN													
YLW - RED													
RED - BLU													
High pressure switch(HPS)	<table border="1" style="width: 100%; text-align: center;"> <thead> <tr> <th></th> <th>Pressure</th> <th>State</th> </tr> </thead> <tbody> <tr> <td rowspan="2">HPS</td> <td>497 ± 22 PSIG</td> <td>Close</td> </tr> <tr> <td>600 ± 15 PSIG</td> <td>Open</td> </tr> </tbody> </table>		Pressure	State	HPS	497 ± 22 PSIG	Close	600 ± 15 PSIG	Open				
	Pressure	State											
HPS	497 ± 22 PSIG	Close											
	600 ± 15 PSIG	Open											
Defrost heater	Measure the resistance using a multimeter. (Part temperature: 14°F - 104°F) <table border="1" style="width: 100%; text-align: center;"> <thead> <tr> <th colspan="3">Normal</th> </tr> <tr> <th>MXZ-2D20NLHZ</th> <th>MXZ-3D24NLHZ</th> <th>MXZ-3D30NLHZ</th> </tr> </thead> <tbody> <tr> <td colspan="3">0.35 kΩ - 0.50 kΩ</td> </tr> </tbody> </table>	Normal			MXZ-2D20NLHZ	MXZ-3D24NLHZ	MXZ-3D30NLHZ	0.35 kΩ - 0.50 kΩ					
Normal													
MXZ-2D20NLHZ	MXZ-3D24NLHZ	MXZ-3D30NLHZ											
0.35 kΩ - 0.50 kΩ													

12-6. TROUBLESHOOTING FLOW

Outdoor unit does not operate.

Ⓐ Check of power supply

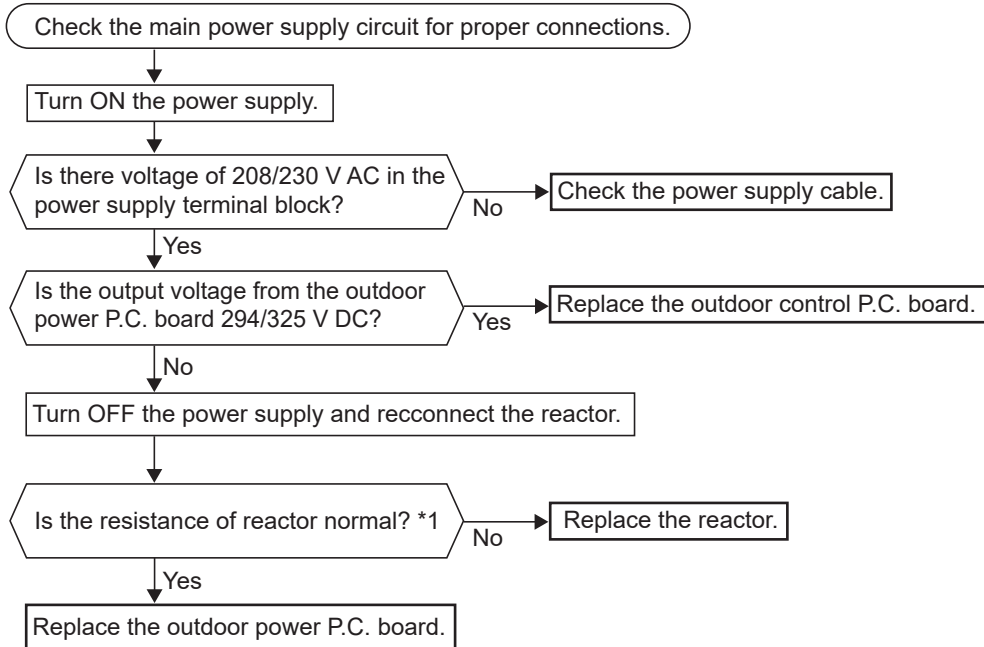

*1 MXZ-2D20NL MXZ-3D24NL MXZ-4D30NL MXZ-5D36NL

Measuring points	Resistance
pin 1 – pin 2	1 Ω or less
pin 3 – pin 4	1 Ω or less

MXZ-5D42NL

MXZ-2D20NLHZ MXZ-3D24NLHZ MXZ-3D30NLHZ

Measuring points	Resistance
–	1 Ω or less

- When unit cannot operate neither by the remote controller nor by EMERGENCY OPERATION switch. Indoor unit does not operate.
- When OPERATION INDICATOR lamp blinks ON and OFF in every 0.5-second. Outdoor unit does not operate.

Ⓑ How to check miswiring and serial signal error (when outdoor unit does not work)

LED indication for communication status

Communication status is indicated by the LED.

Unit status

Blinking: normal communication
Lit: abnormal communication or not connected

Pattern 1 and 2 is repeatedly displayed alternately. Each pattern is displayed for 15 seconds.

NOTE: "Lit" in the table below does not indicate abnormal communication.

Outdoor control P.C. board

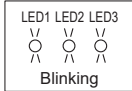

Pattern	LED 1	LED 2	LED 3
1	Unit A status	Unit B status	Lit
2	Unit C status	Unit D status	Not lit
3	Unit E status	—	Blinking

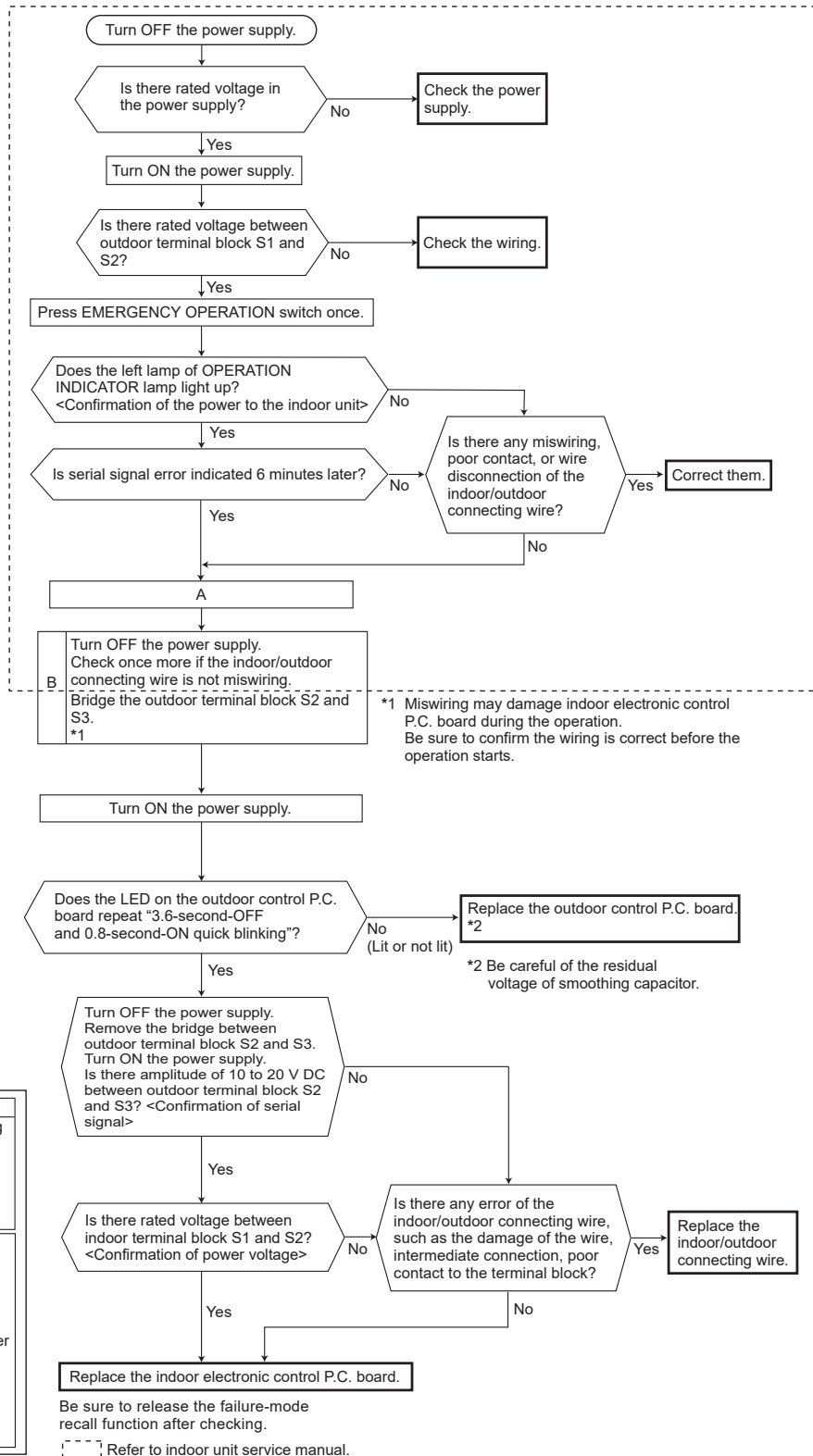

The cooling operation or heating operation does not operate.

© Check of R.V. coil

• When cooling operation does not work,

1. Disconnect the lead wire leading to the compressor.
2. 3 minutes after turning ON the power supply, start EMERGENCY OPERATION in COOL mode.

CNAC CN712	Outdoor control P.C. board
CNAC2	Outdoor power P.C. board

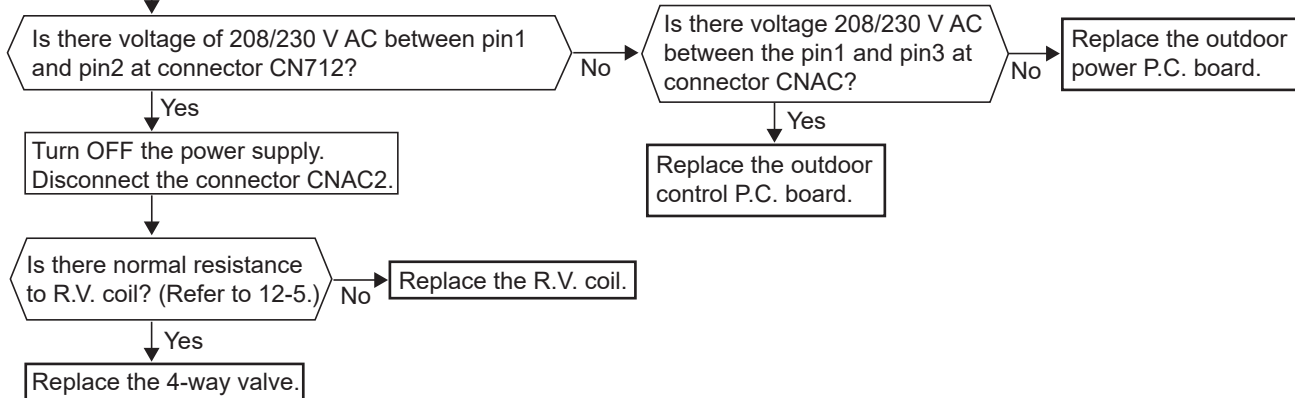

• When heating operation does not work,

1. Disconnect the lead wire leading to the compressor.
2. 3 minutes after turning ON the power supply, start EMERGENCY OPERATION in HEAT mode.

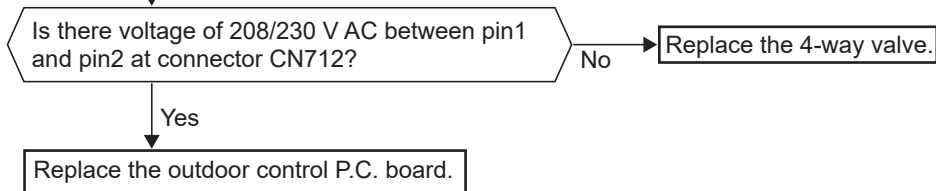

- When cooling, heat exchanger of non-operating indoor unit frosts.
- When heating, non-operating indoor unit gets warm.

④ **Check of LEV**

Turn ON the power supply to the outdoor unit after checking LEV coil is mounted to the LEV body securely.

Is "click - click" sound heard?
Or, do you feel vibration of LEV coil with your hand?

Yes → Normal

No

Disconnect the connectors.

MXZ-2D

CN791: LEV A, CN792: LEV B

MXZ-3D/4D/5D

CN791: LEV A, CN792: LEV B, CN793: LEV C

CN794: LEV D (**MXZ-4D/5D**),

CN795: LEV E (**MXZ-5D**),

Is there normal resistance to LEV coil?
(Refer to 12-5.)

Yes → Replace the outdoor control P.C. board.

No

Replace LEV coil.

CN791	Outdoor control P.C. board
CN792	
CN793	
CN794	
CN795	

- When heating, room does not get warm.
- When cooling, room does not get cool.

Ⓔ How to check inverter/compressor

Disconnect the terminal of the compressor or the connector (CNMC) between the compressor and the outdoor power P.C. board. 3 minutes after the power supply is turned ON, start EMERGENCY OPERATION.

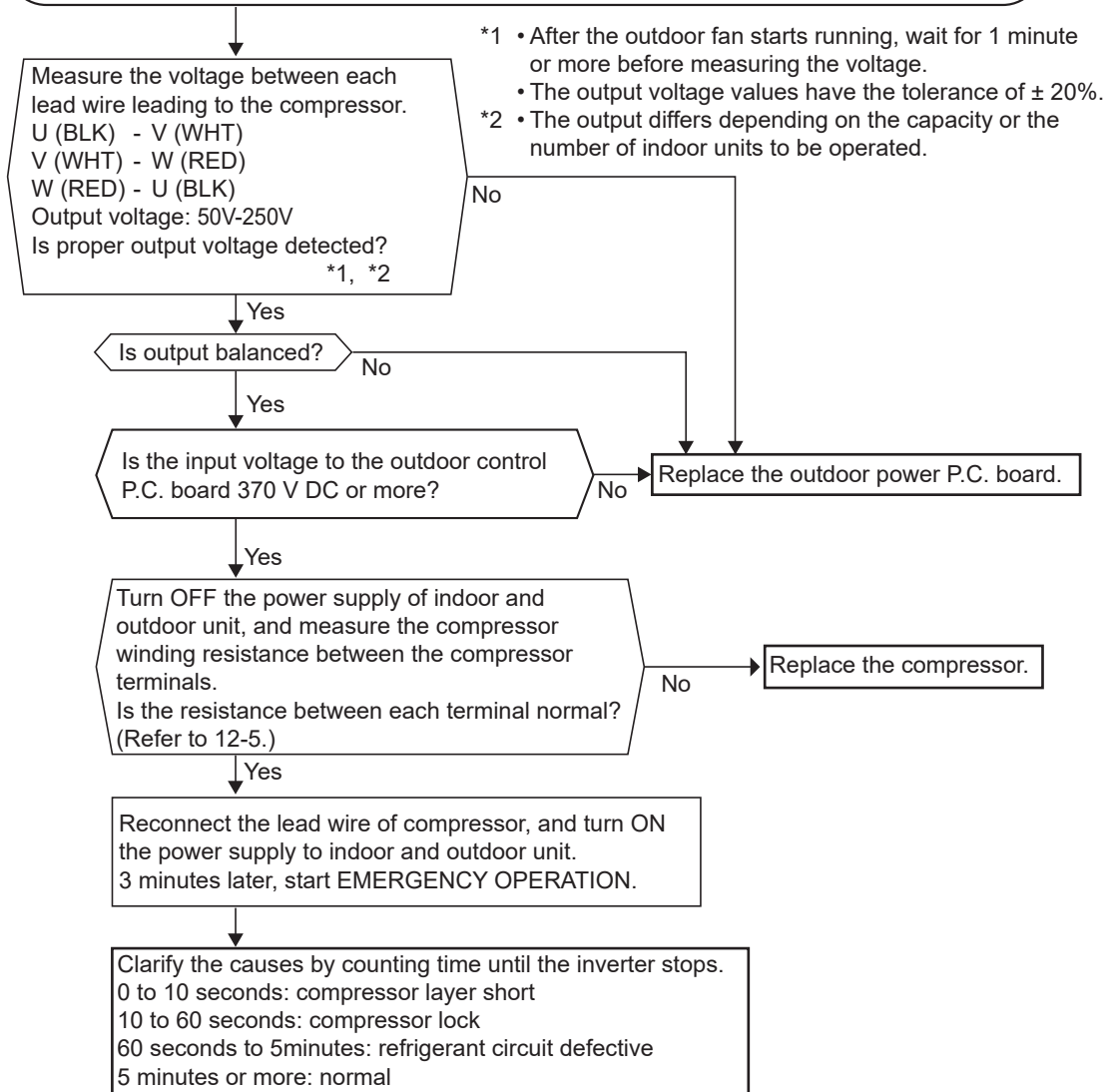

• When thermistor is abnormal,

Ⓕ Check of outdoor thermistors

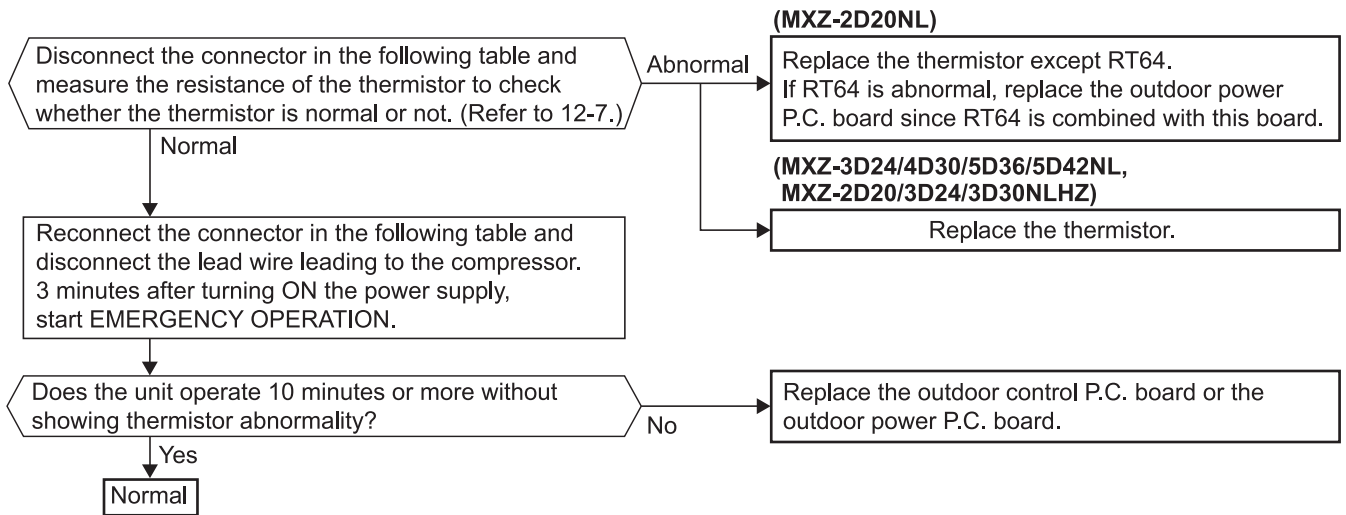

Thermistor	Symbol	Connector, Pin No.	Board
Defrost	RT61	Between CNTH1 pin1 and pin2	Outdoor control P.C. board
Discharge temperature	RT62	Between CNTH1 pin3 and pin4	
Outdoor heat exchanger temperature	RT68	Between CNTH1 pin7 and pin8	
Ambient temperature	RT65	Between CNTH2 pin1 and pin2	
Fin temperature	RT64	Between CN171 pin1 and pin2	Outdoor power P.C. board

• Fan motor does not operate or stops operating shortly after starting the operation.

Ⓒ Check of outdoor fan motor

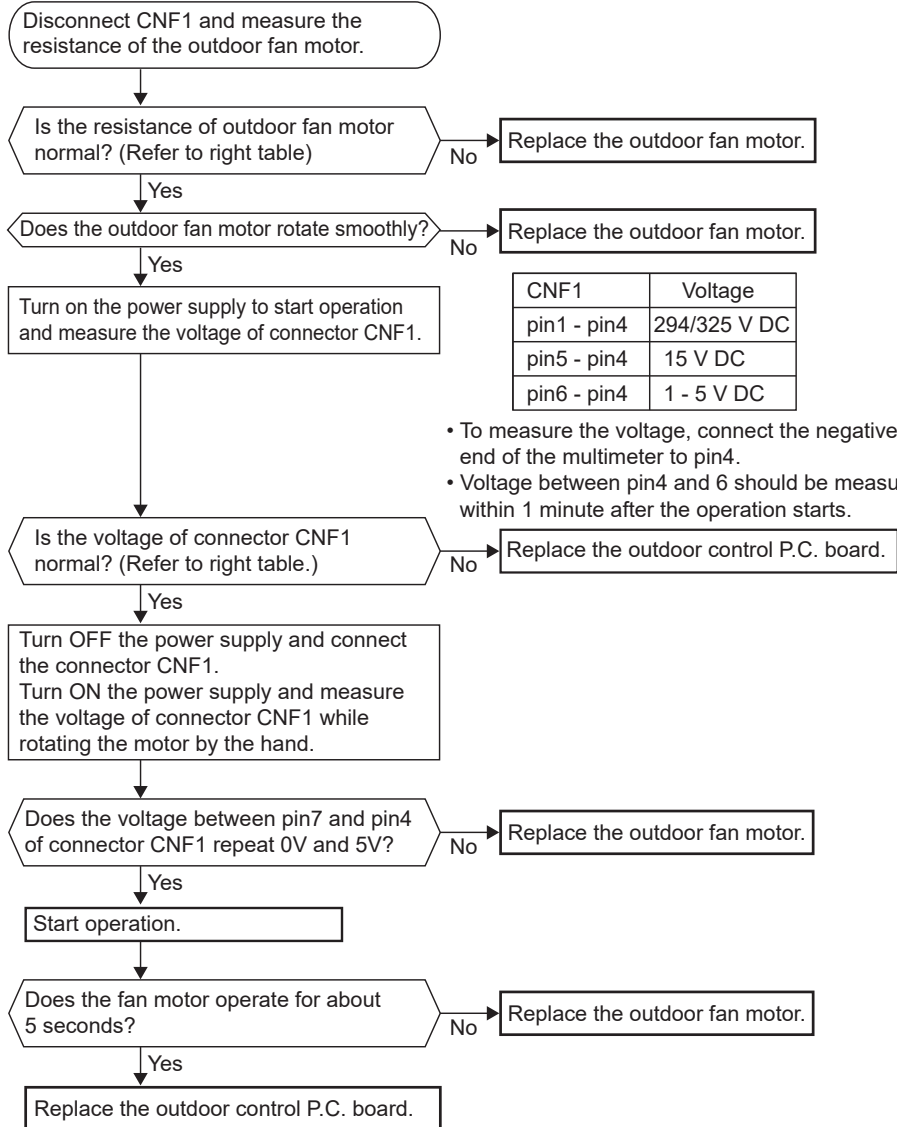

CNF1	Outdoor control P.C. board
------	----------------------------

Model name of fan motor:
SIC-82XX-XXXX-X, SIC-88XX-XXXX-X

Measuring points	Resistance
pin1 - pin4	1.1 MΩ
pin5 - pin4	40 kΩ
pin6 - pin4	220 kΩ
pin7 - pin4	∞

ZWB27XXXXXX

Measuring points	Resistance
pin1 - pin4	0.9 – 1.2 MΩ
pin5 - pin4	40 – 52 MΩ
pin6 - pin4	170 – 210 MΩ
pin7 - pin4	5.8 – 7.1 MΩ

- To measure the voltage, connect the negative (-) end of the multimeter to pin4.
- Voltage between pin4 and 6 should be measured within 1 minute after the operation starts.

- To measure the resistance, connect the negative (-) end of the multimeter to pin4.
- See the spec name plate indicated in the diagram for the model name of fan motor.
- Where "X" in model name of fan motor represents numbers and letters

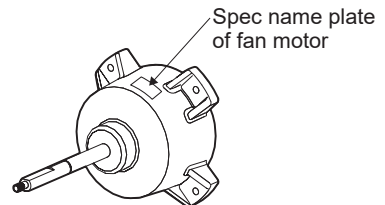

• When the operation frequency does not go up from the lowest frequency.

Ⓜ Check of HPS

CN63H	Outdoor control P.C. board
-------	----------------------------

1. Disconnect the connector CN63H on the outdoor control P.C. board.
2. Disconnect the connector connecting HPS and the thermal protector.
3. Check the resistance of HPS after 1 minute has passed since the outdoor unit power supply was turned OFF.

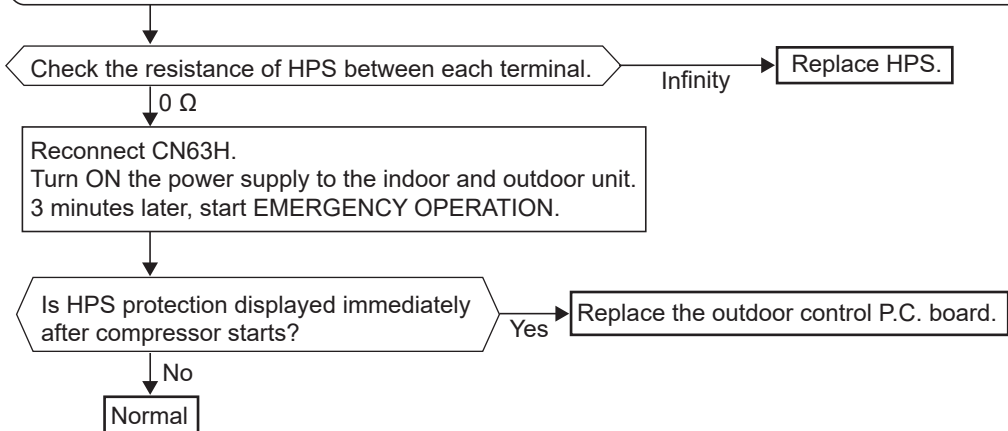

① The other cases

Indoor unit does not operate. (different operating models in multi system)

- When you try to run 2 indoor units simultaneously, one for cooling and the other for heating, the unit which transmits signal to the outdoor units first decides the operation mode.
- When the above situation occurs, set all the indoor units to the same mode, turn OFF the indoor units, and then turn them back ON.
- Though the top of the indoor unit sometimes gets warm, this does not mean malfunction. The reason is that the refrigerant gas continuously flows into the indoor unit even while it is not operating.

Ⓜ Check of bus-bar voltage

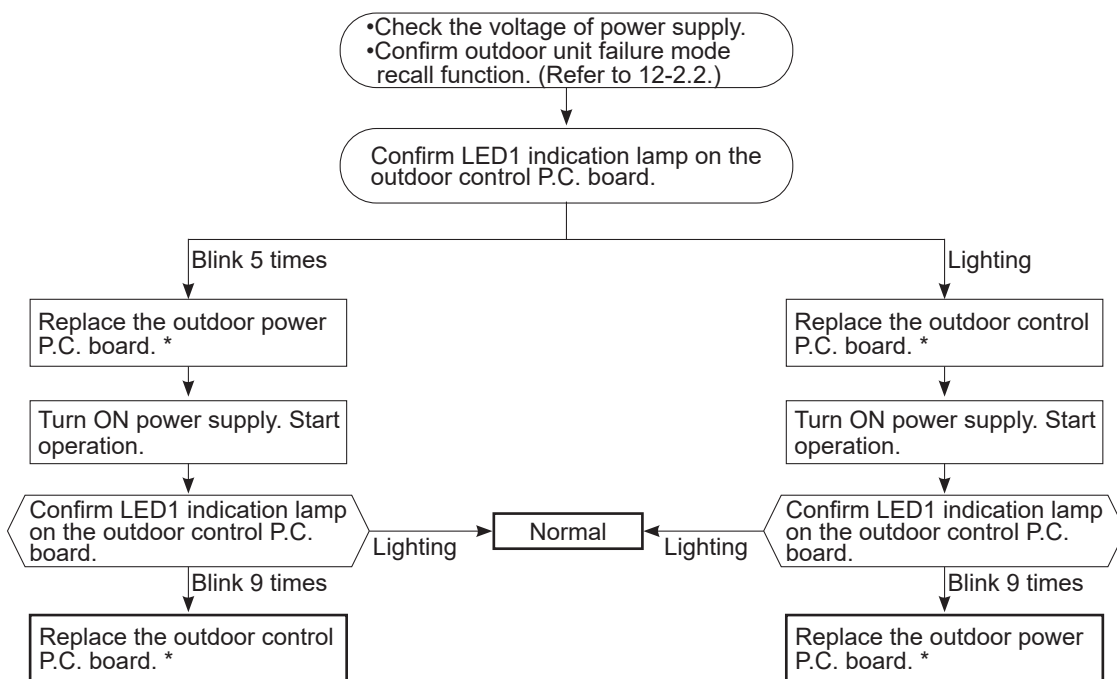

* Turn OFF power supply before removing P.C. board.

Ⓚ Check of thermal protector

1. Disconnect the connector CN63H on the outdoor control P.C. board.
2. Disconnect the connector connecting HPS and the thermal protector, and then check the conduction of the thermal protector.

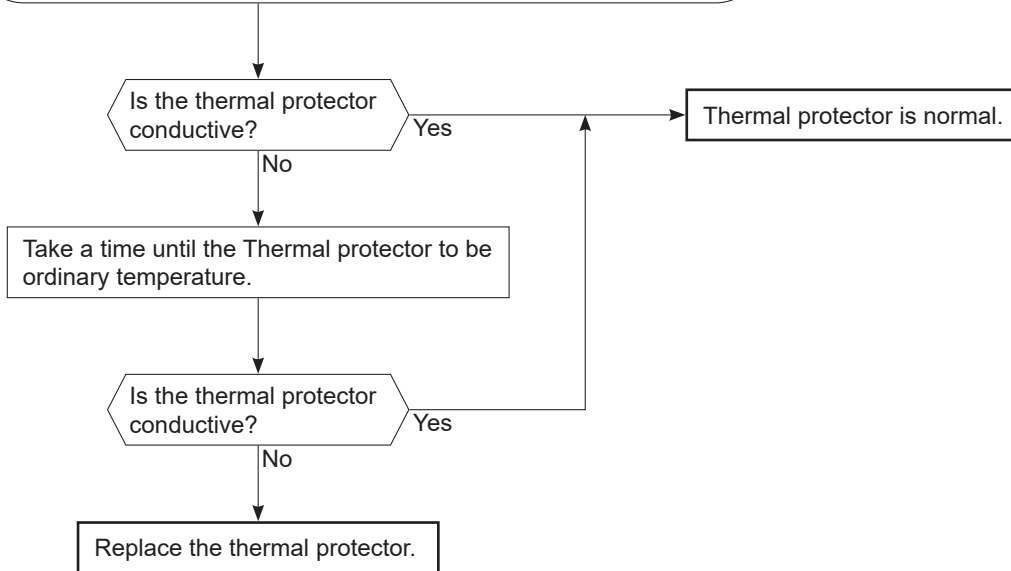

12-7. TEST POINT DIAGRAM AND VOLTAGE

1. Outdoor control P.C. board

MXZ-2D20NL

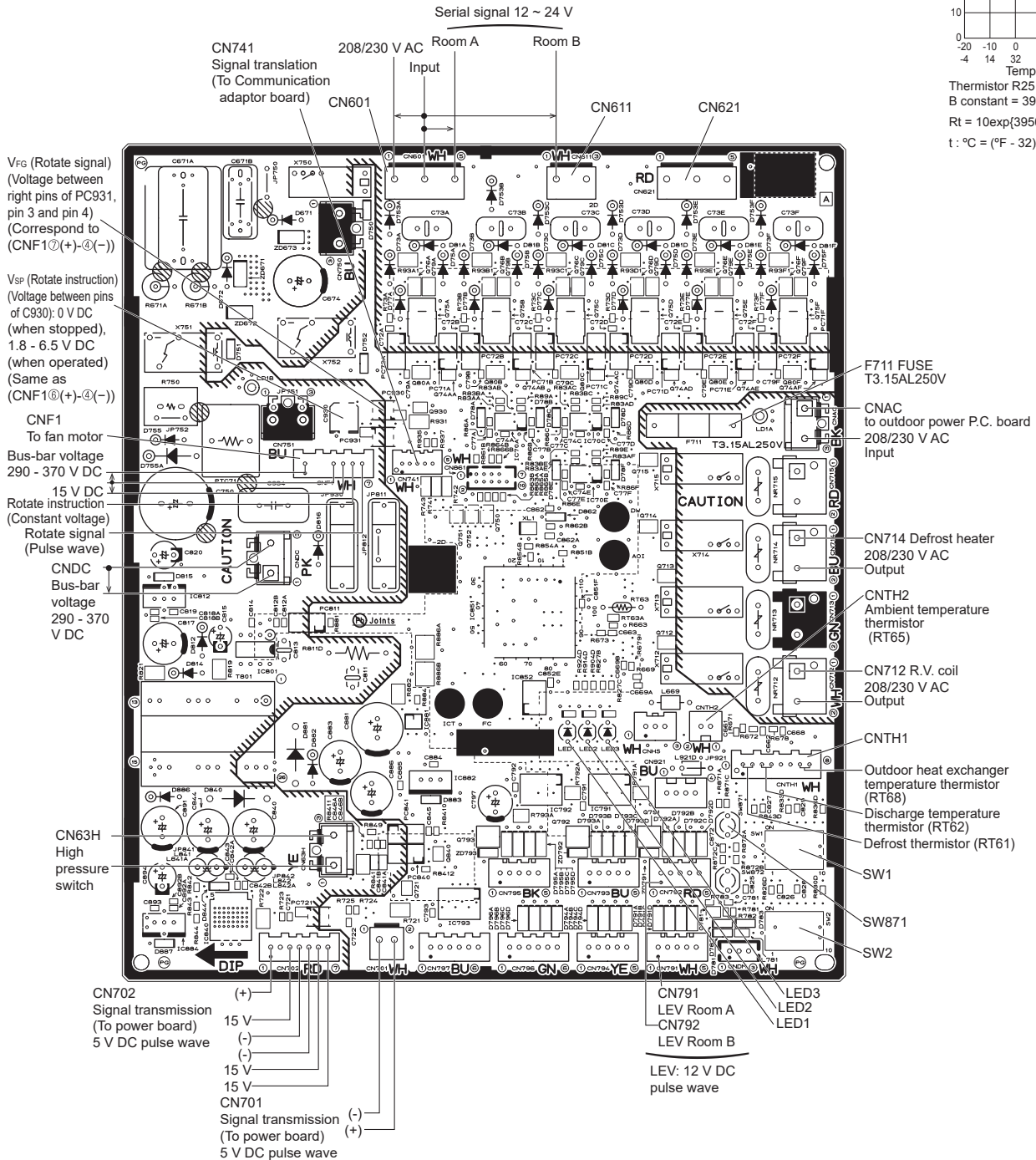
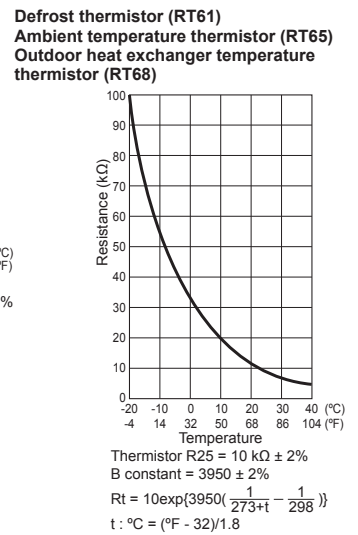
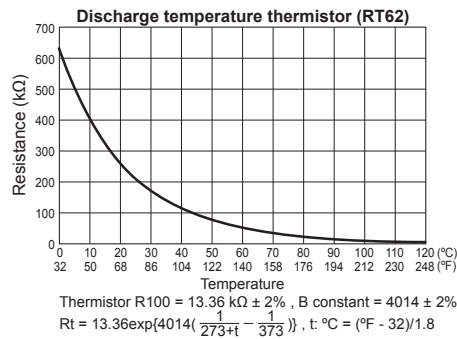

1. Outdoor control P.C. board

MXZ-3D24NL
MXZ-4D30NL
MXZ-5D36NL
MXZ-5D42NL

MXZ-2D20NLHZ
MXZ-3D24NLHZ
MXZ-3D30NLHZ

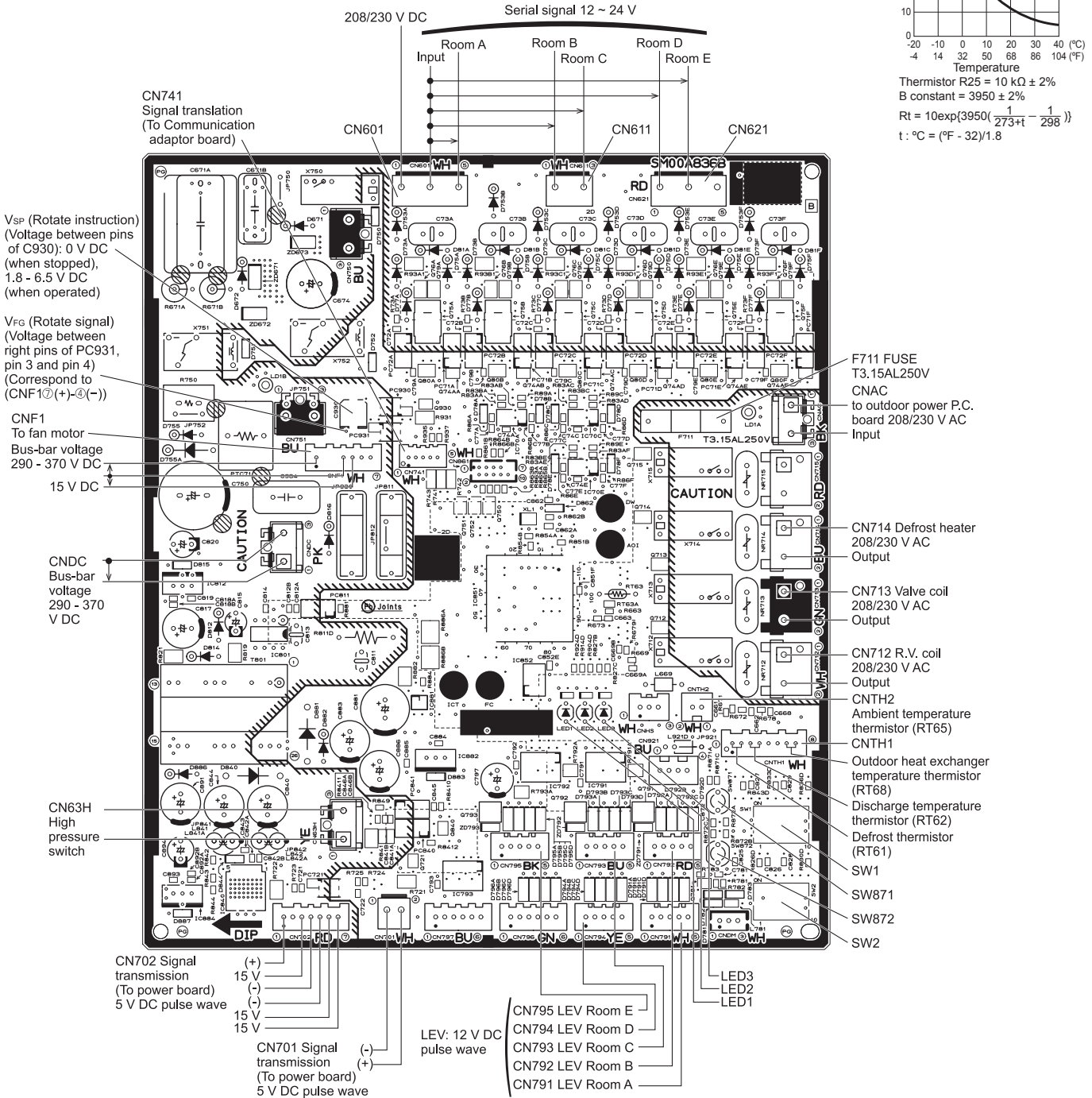
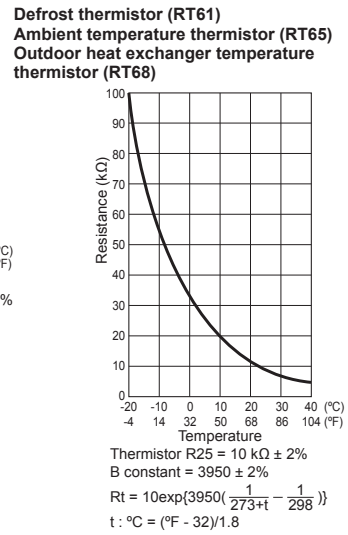
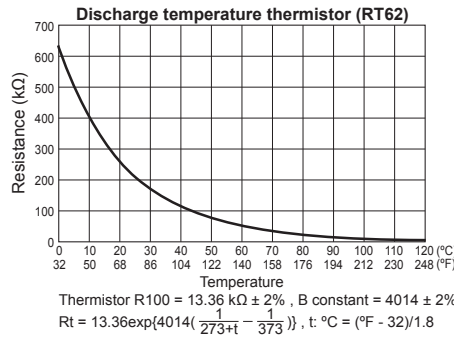

2. Outdoor power P.C. board MXZ-2D20NL

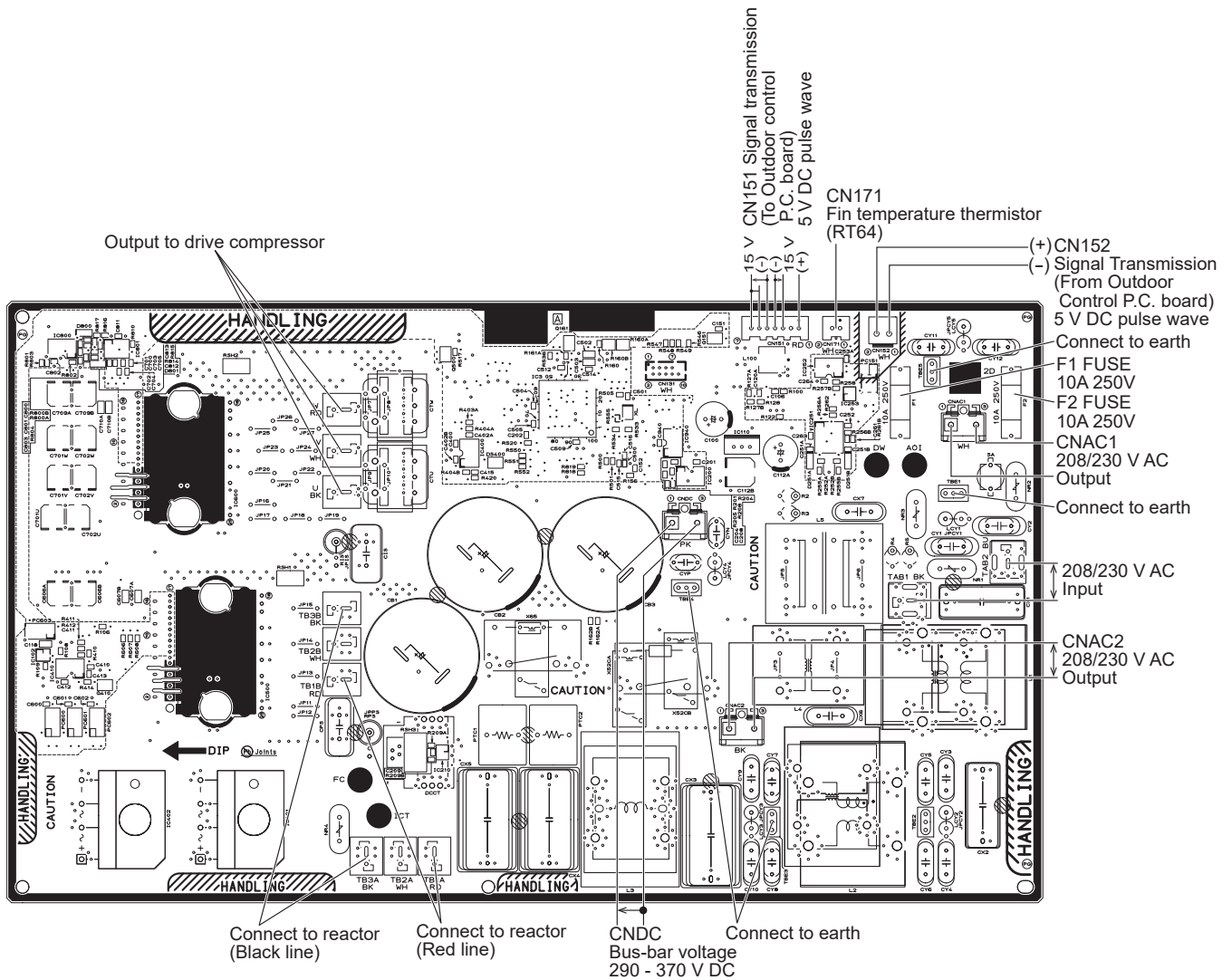

Fin temperature thermistor (RT64)

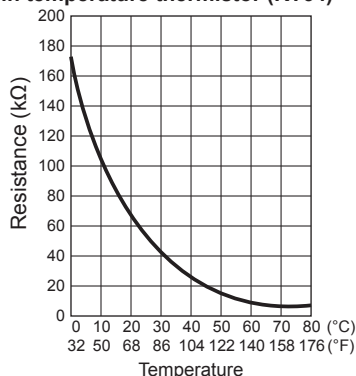

Thermistor R50 = 17 kΩ ± 2%

B constant = 4150 ± 3%

$$R_t = 17 \exp\left\{4150 \left(\frac{1}{273+t} - \frac{1}{323} \right)\right\}$$

t: °C = (°F - 32)/1.8

2. Outdoor power P.C. board

MXZ-3D24NL **MXZ-2D20NLHZ**
MXZ-4D30NL **MXZ-3D24NLHZ**
MXZ-5D36NL **MXZ-3D30NLHZ**
MXZ-5D42NL

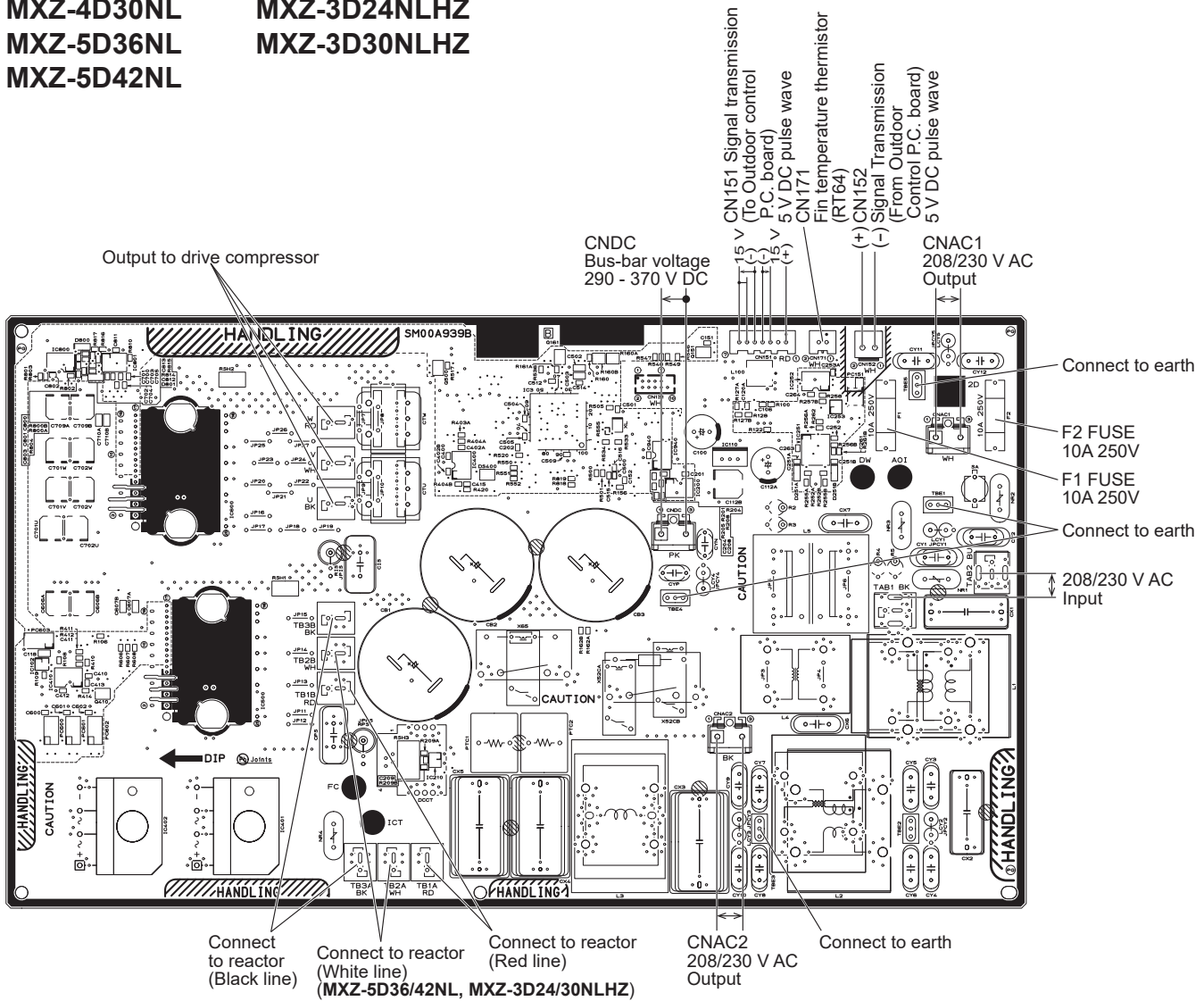

Fin temperature thermistor (RT64)

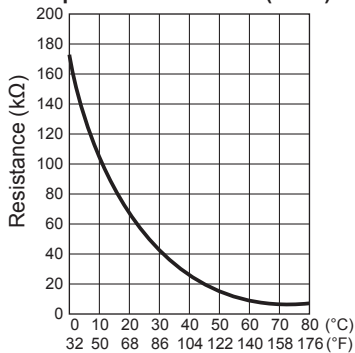

Thermistor $R_{50} = 17 \text{ k}\Omega \pm 2\%$
 B constant = $4150 \pm 3\%$
 $R_t = 17 \exp\left(4150 \left(\frac{1}{273+t} - \frac{1}{323}\right)\right)$
 $t : ^\circ\text{C} = (^\circ\text{F} - 32)/1.8$

<Detaching method of the terminal with locking mechanism>

The terminal which has the locking mechanism can be detached as shown below.

There are 2 types of the terminal with locking mechanism.

The terminal without locking mechanism can be detached by pulling it out.

Check the shape of the terminal before detaching.

(1) Slide the sleeve and check if there is a locking lever or not.

(2) The terminal with this connector shown below has the locking mechanism.

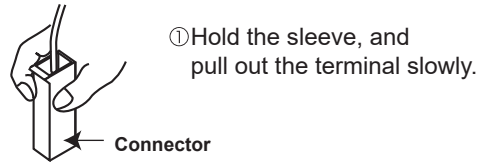
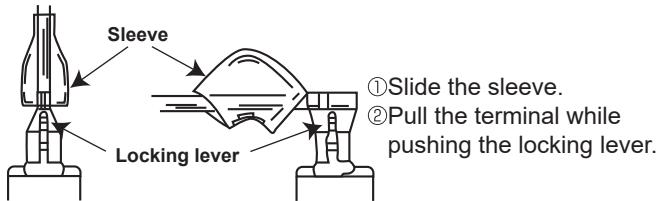

13-1. MXZ-2D20NL

NOTE: Turn OFF the power supply before disassembly.

————>: Indicates the visible parts in the photos/figures.
----->: Indicates the invisible parts in the photos/figures.

OPERATING PROCEDURE	PHOTOS/FIGURES
<p>1. Removing the cabinet and the panels</p> <p>(1) Remove all the screws of the service panel, and remove the service panel.</p> <p>(2) Disconnect the power supply cord and indoor/outdoor connecting wires.</p> <p>(3) Remove all the screws of the top panel, and remove the top panel.</p> <p>(4) Remove all the screws of the cabinet, and remove the cabinet.</p> <p>(5) Remove all the screws of the back panel, and remove the back panel (Photo 3).</p>	<p>Photo 1</p> <p>Screws of the top panel</p> <p>Screws of the cabinet</p> <p>Screws of the service panel</p> <p>Screws of the cabinet</p>
<p>Photo 3</p> <p>Screw of the rear guard</p> <p>Screws of the back panel</p> <p>Screws of the back panel</p> <p>Screws of the back panel</p>	<p>Photo 2</p> <p>Screws of the top panel</p> <p>Screws of the cabinet</p> <p>Screws of the sub panel</p> <p>Screws of the cabinet</p>

OPERATING PROCEDURE

2. Removing the outdoor control P.C. board, the outdoor power P.C. board and the reactor

- (1) Remove the service panel (Photo 1).
- (2) Disconnect the power supply cord and indoor/outdoor connecting wires.
- (3) Remove the top panel, the cabinet, and the back panel (Photo 1, 2, 3).
- (4) Disconnect all the connectors and the lead wires on the outdoor control P.C. board.
- (5) Disengage all the catches of the outdoor control P.C. board, and remove the outdoor control P.C. board.
- (6) Remove all the screws of the electrical box assembly, disengage all the catches of the electrical box assembly, and remove the electrical box assembly.
- (7) Remove all the screws of outdoor control P.C. board holder, and remove the outdoor control P.C. board holder.
- (8) Remove all the screws of the reactor, and remove the reactor.
- (9) Remove all the screws of the reactor bed, and remove the reactor bed.
- (10) Remove all the screws of the heat sink support, and remove the heat sink support.
- (11) Remove all the screws fixing the outdoor power P.C. board.
- (12) Disconnect the connectors and the lead wires on the outdoor power P.C. board.

PHOTOS/FIGURES

Photo 4

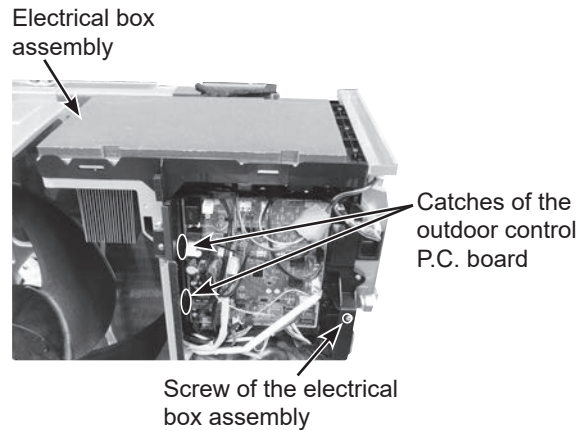

Photo 5

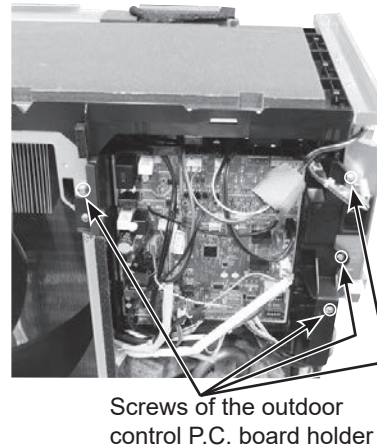

Photo 6

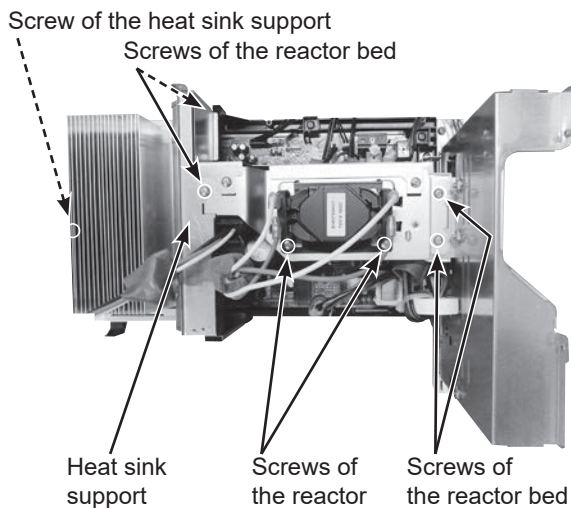
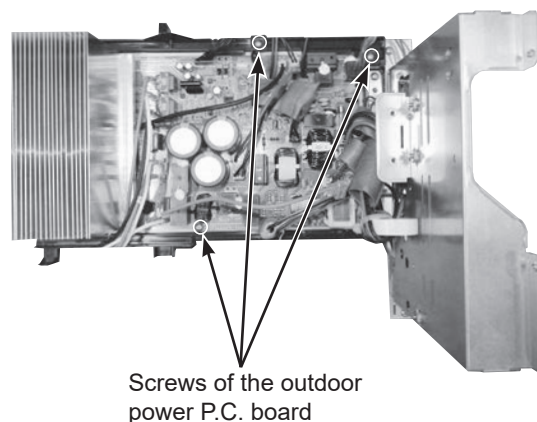

Photo 7



OPERATING PROCEDURE

3. Removing the fan motor

- (1) Remove the service panel (Photo 1).
- (2) Disconnect the power supply cord and indoor/outdoor connecting wires.
- (3) Remove the top panel, the cabinet, and the back panel (Photo 1, 2, 3).
- (4) Disconnect the connectors of CN712, CNF1, CNTH1, CNTH2, CN63H, CN791, CN792 on the outdoor control P.C. board and disconnect the relay connector of the compressor lead wire.
- (5) Remove all the screws of the electrical box assembly, and remove the electrical box assembly (Photo 4).
- (6) Remove the propeller fan.
- (7) Remove the fan motor.

NOTE: The propeller fan nut is a reverse thread.

PHOTOS/FIGURES

Photo 8

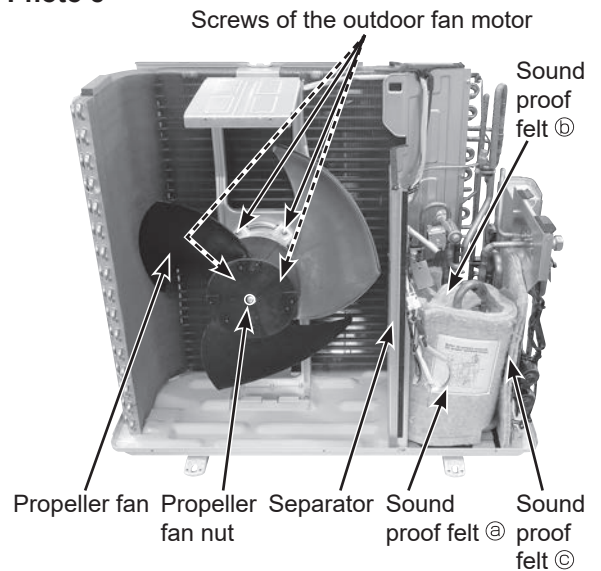

OPERATING PROCEDURE

4. Removing the compressor and the 4-way valve

- (1) Remove the service panel (Photo 1).
- (2) Disconnect the power supply cord and indoor/outdoor connecting wires.
- (3) Remove the top panel, the cabinet, and the back panel (Photo 1, 2, 3).
- (4) Recover gas from the refrigerant circuit.
NOTE: Recover gas from the pipes until the pressure gauge shows 0 PSIG.
- (5) Disconnect the outdoor control P.C. board connectors: CNF1, CNTH1, CNTH2, CN63H, CN791, CN792, CN712.
- (6) Remove all the screws of the electrical box assembly, and remove the electrical box assembly (Photo 4).
- (7) Remove the propeller fan.
- (8) Remove the sound proof felt ⓐ, ⓑ and ⓒ.
- (9) Remove the terminal cover, and remove thermal protector (TRS).
- (10) Disconnect the compressor lead wire from the terminal of the compressor (U, V, W).
- (11) Remove all the screws of the separator, and remove the separator.
- (12) Detach all the brazed parts of the compressor suction and discharge pipes.
- (13) Remove all the compressor nuts and remove the compressor.
- (14) Detach all the brazed parts of the 4-way valve and pipe.

NOTE: Be careful not to expose the fusible plug to the braze torch flame or transfer heat to it. The temperature of the fusible plug must not become 140°F (60°C) or higher while working. Protect the fusible plug with a wet cloth when necessary.
(The fusible plug breaks at 158°F [70°C]).

NOTE: If the red labels have been removed during the operation, put them back in the original position after the operation. Red labels indicate the use of flammable refrigerants.

PHOTOS/FIGURES

Photo 9

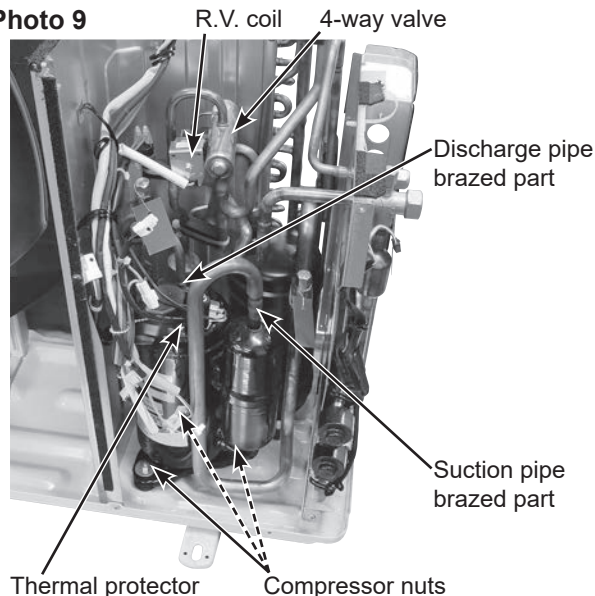
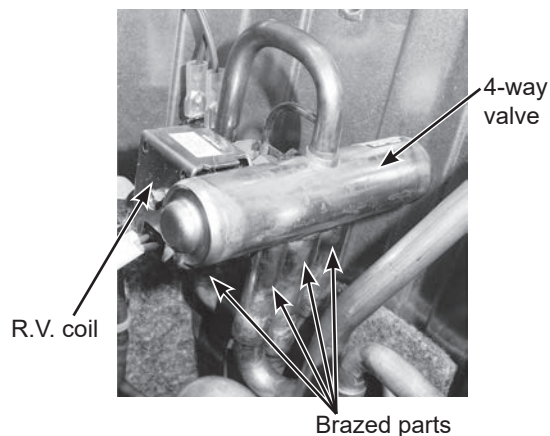
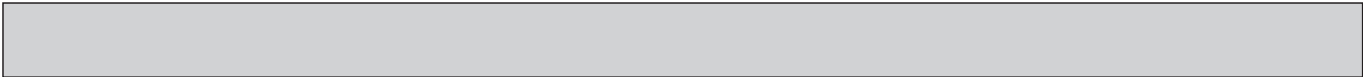
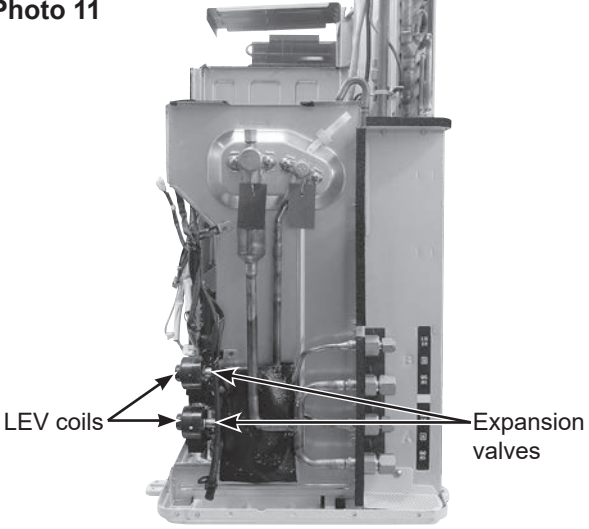
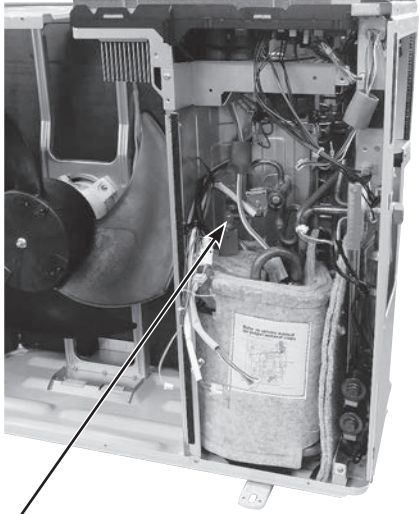

Photo 10





OPERATING PROCEDURE	PHOTOS/FIGURES
<p>5. Removing the expansion valve</p> <p>NOTE: Gas recovery is not required if the unit is pumped down.</p> <ol style="list-style-type: none">(1) Remove the top panel and the service panel (Refer to section 1).(2) Disconnect the power supply cord and indoor/outdoor connecting wires.(3) Remove all the LEV coils.(4) Detach all the brazed parts of the expansion valves and pipes.	<p>Photo 11</p>  <p>LEV coils</p> <p>Expansion valves</p> <p>Detailed description: A black and white photograph showing the front of a vertical HVAC unit. Two expansion valves are visible on the right side, and two LEV coils are on the left. Arrows point from the labels 'LEV coils' and 'Expansion valves' to their respective components.</p>
<p>6. Before using the service port (High pressure side)</p> <ol style="list-style-type: none">(1) Remove the service panel (Photo 1).(2) Disconnect the power supply cord and indoor/outdoor connecting wires.(3) Remove the top panel, the cabinet, and the back panel (Photo 1, 2, 3).(4) Disconnect all the connectors and the lead wires on the outdoor control P.C. board.(5) Remove all the screws of outdoor control P.C. board holder, and remove the outdoor control P.C. board holder (Photo 5).(6) Make sure that the service port is visible.	<p>Photo 12</p>  <p>Service port (High pressure side)</p> <p>Detailed description: A black and white photograph showing the interior of the HVAC unit. A service port is visible on the high pressure side, indicated by an arrow from the label 'Service port (High pressure side)'. The image shows various internal components, pipes, and wiring.</p>

13-2. MXZ-3D24NL MXZ-4D30NL MXZ-2D20NLHZ

NOTE: Turn OFF the power supply before disassembly.

Photos: MXZ-4D30NL

OPERATING PROCEDURE

1. Removing the panels

- (1) Remove all the screws fixing the top panel, and remove the top panel.
- (2) Remove all the screws fixing the service panel.
- (3) Pull down on the service panel, and remove the service panel.
- (4) Disconnect the power supply cord and indoor/outdoor connecting wires.
- (5) Remove all the screws fixing the front panel, and remove the front panel.
- (6) Remove all the screws fixing the back panel, and remove the back panel.

PHOTOS/FIGURES

Photo 1

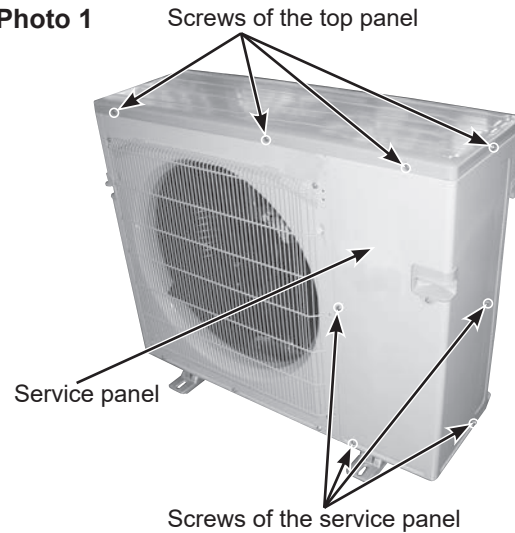

Photo 2

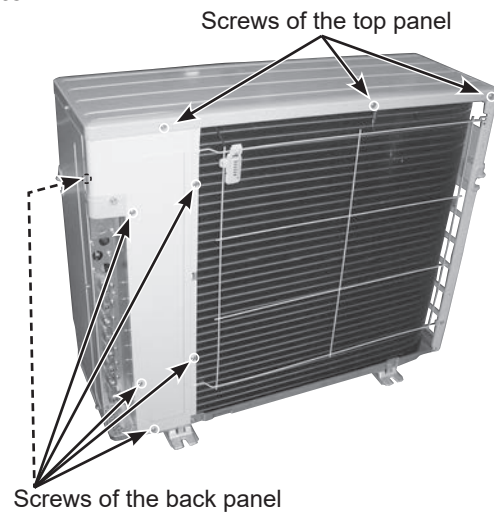
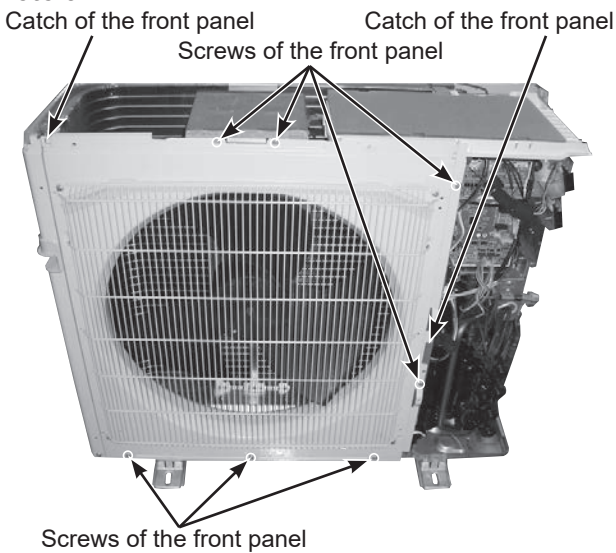

Photo 3



OPERATING PROCEDURE

2. Removing the outdoor control P.C. board, the reactor, the outdoor power P.C. board, and the heatsink

- (1) Remove the top panel and the service panel (Refer to section 1).
- (2) Disconnect the power supply cord and indoor/outdoor connecting wires.
- (3) Disconnect the wire-to-wire connector of the compressor lead wire (Photo 4).
- (4) Disconnect all the connectors on the outdoor control P.C. board.
- (5) Remove the releasable cable tie securing the lead wires of core, TBE1, CNTH2, and CNAC2 (Photo 4).
- (6) Remove all the screws fixing the outdoor control P.C. board holder (Photo 4).
- (7) Remove the lead wires of TBE1, CNTH2, and CNAC2 from the right hook on the top of the outdoor control P.C. board holder (Photo 4, Ⓐ).
- (8) Remove the lead wires of CN151 and CN152 from the left hooks on the top and the bottom of the outdoor control P.C. board holder (Photo 4, Ⓑ and 5).
- (9) Remove the outdoor control P.C. board holder.
- (10) Disengage all the catches of the outdoor control P.C. board holder, and remove the outdoor control P.C. board (Photo 6).
- (11) Disconnect all the lead wires from the reactor (Photo 7).
- (12) Remove all the screws fixing the reactor, and remove the reactor (Photo 7).
- (13) Remove all the lead wires from the clamps on the separator (Photo 8).

PHOTOS/FIGURES

Photo 6

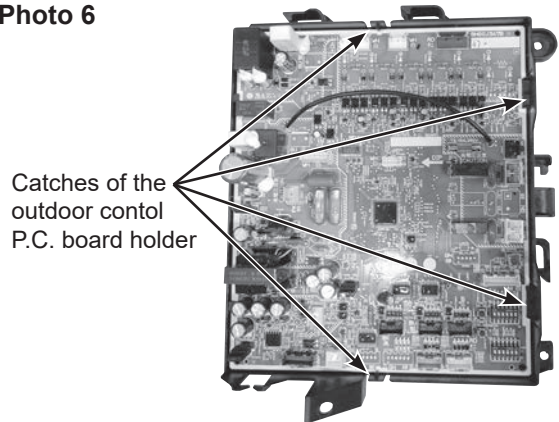
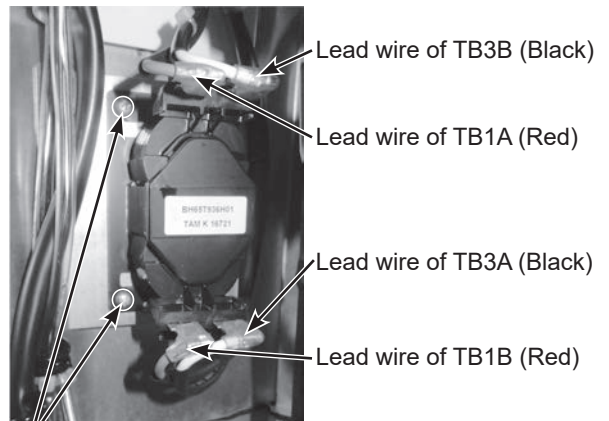

Photo 7



Screws of the reactor

Photo 8

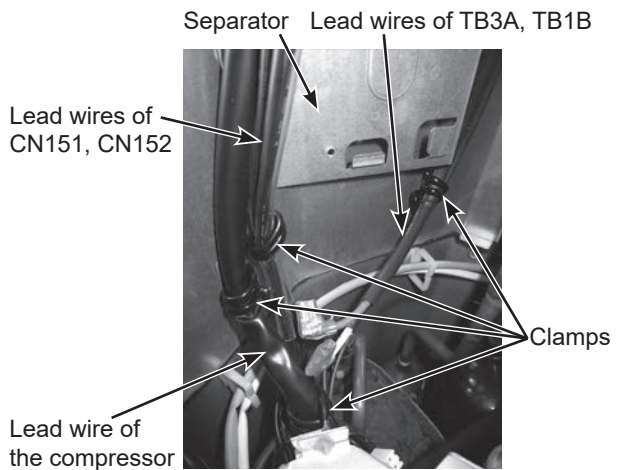

Photo 4

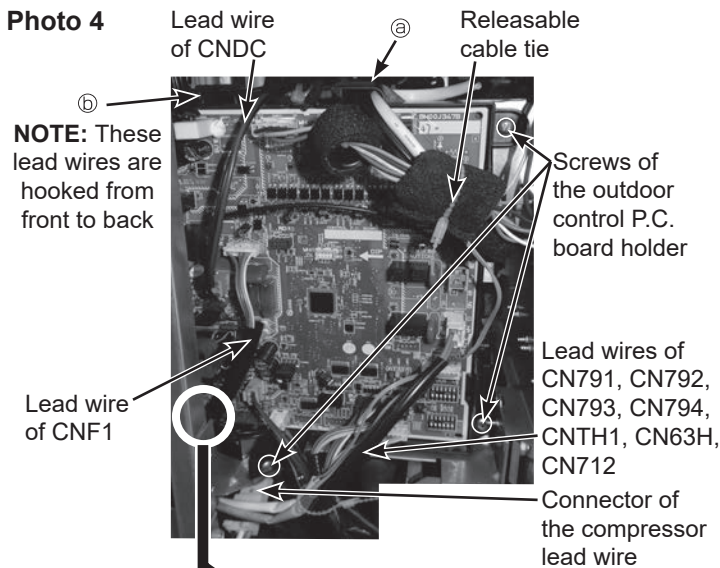
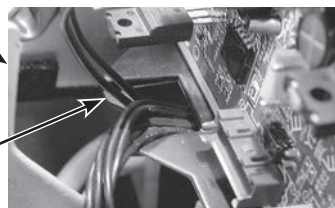

Photo 5

Left hook on the bottom of control P.C. board (CN151, CN152)



OPERATING PROCEDURE

- (14) Disengage all the catches of the PB cover, and remove the PB cover (Photo 9).
 - (15) Remove the screw fixing the outdoor power P.C. board and all the screws fixing the outdoor power P.C. board and the heatsink (Photo 10).
 - (16) Disengage all the catches of the outdoor power P.C. board, and lift the outdoor power P.C. board (Photo 10).
 - (17) While lifting the outdoor power P.C. board, disconnect the lead wires, the connectors, and the earth wires; then remove the outdoor power P.C. board (Photo 11).
- NOTE:** When reassembling, pass the lead wire of the CN171 through the notch and behind the lead wire of the compressor (Photo 12).
- (18) Remove all the screws of the heatsink fixing parts and remove the heatsink fixing parts (Photo 13).
 - (19) Remove the heatsink.

PHOTOS/FIGURES

Photo 9

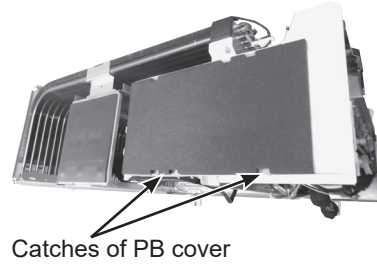

Photo 10

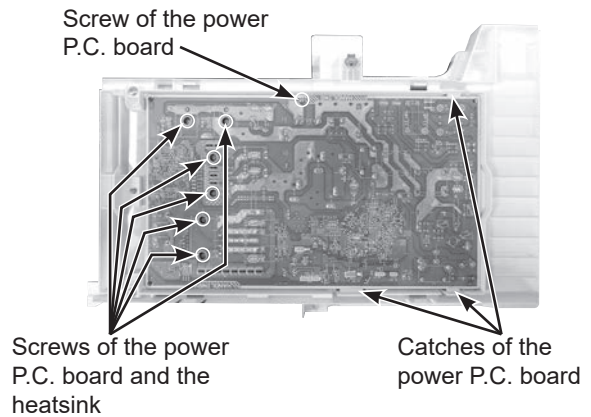
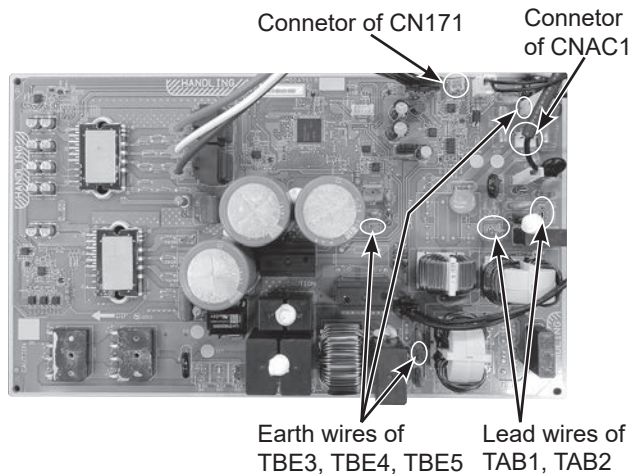
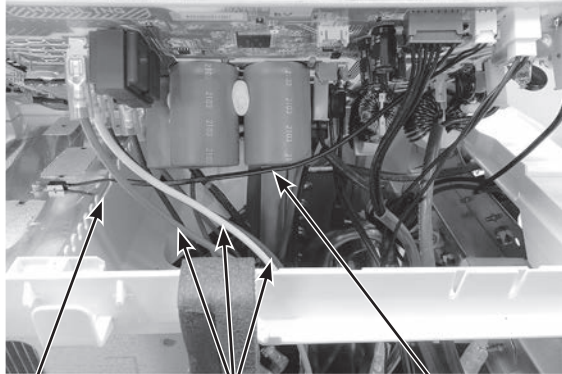

Photo 11



OPERATING PROCEDURE

Photo 12



Notch

Lead wires of
compressor

Lead wire of
CN171

PHOTOS/FIGURES

Photo 13

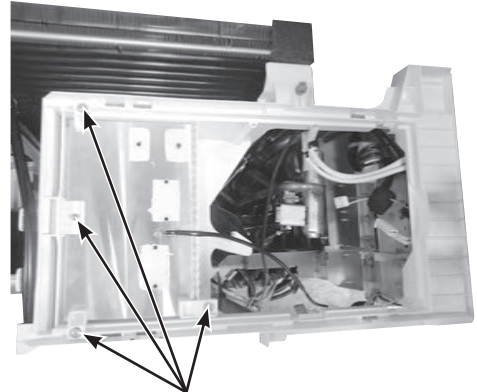

Screws of fixing parts of the heat sink

3. Removing the fan motor

- (1) Remove the top panel, the service panel, and the front panel (Refer to section 1).
- (2) Disconnect the power supply cord and indoor/outdoor connecting wires.
- (3) Disconnect the connector of CNF1 on the outdoor control P.C. board.
- (4) Remove the propeller fan.
- (5) Remove the fan motor.

NOTE: The propeller fan nut is a reverse thread.

Photo 14

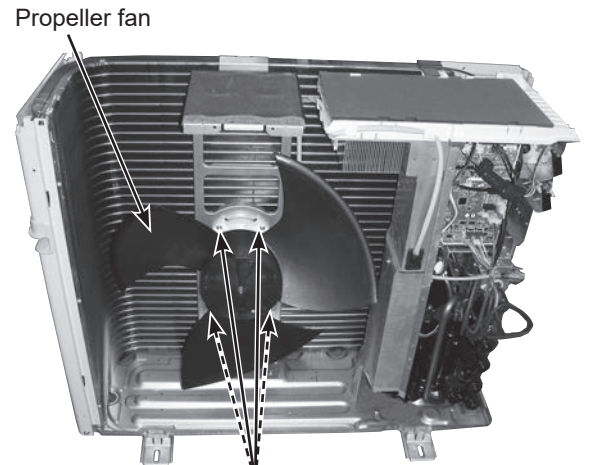

Propeller fan

Screws of the outdoor fan motor

OPERATING PROCEDURE

4. Removing the fusible plug (the 4-way valve assembly)

- (1) Remove the top panel, the service panel, and the front panel (Refer to section 1).
- (2) Disconnect the power supply cord and indoor/outdoor connecting wires, and remove the back panel.
- (3) Recover gas from the refrigerant circuit.
NOTE: Recover gas from the pipes until the pressure gauge shows 0 PSIG.
- (4) Disconnect the outdoor control P.C. board connectors: CNF1, CNTH1, CNTH2, CN63H, CN712, CN791, CN792, CN793 (**MXZ-3D, MXZ-4D**), CN794 (**MXZ-3D, MXZ-4D**)
- (5) Remove all the screws fixing the electrical parts, and remove the electrical parts (Photo 15).
- (6) Remove the propeller fan.
- (7) Remove all the screws fixing the separator, and remove the separator.

NOTE: When installing the separator, insert the tabs of the heat exchanger into the separator.

- (8) Remove all the sound proof felts.
- (9) Remove the screws of the 4-way valve assembly and detach the brazed part of the 4-way valve assembly (including fusible plug) (Photo 16).

NOTE 1: Be careful not to expose the fusible plug to the braze torch flame or transfer heat to it. The temperature of the fusible plug must not become 140°F (60°C) or higher while working. Protect the fusible plug with a wet cloth when necessary. (The fusible plug breaks at 158°F [70°C]). (Photo 17)

NOTE 2: After attaching the 4-way valve assembly, be sure to attach a rubber mount below the fusible plug. Make sure that the rubber mount touches the flare nut. (Photo 17)

PHOTOS/FIGURES

Photo 15

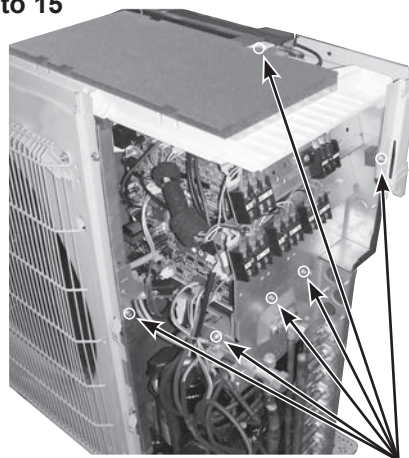

Fixing screws of the electrical parts

Photo 16

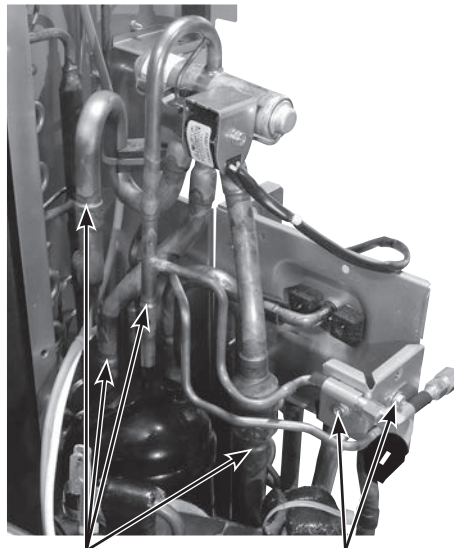

Brazed part of the 4-way valve assembly

Screws of the 4-way valve assembly

Photo 17

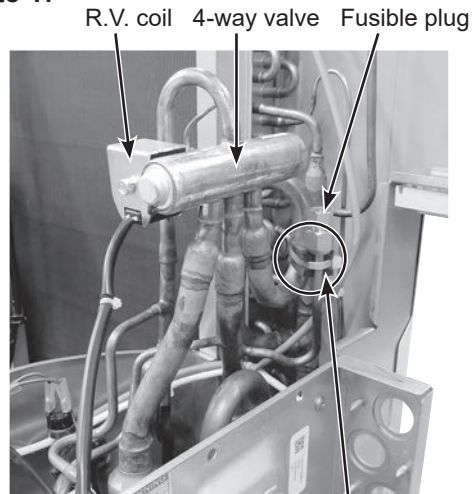

Rubber mount

OPERATING PROCEDURE

5. Removing the compressor and 4-way valve

- (1) Remove the top panel, the service panel, and the front panel (Refer to section 1).
- (2) Disconnect the power supply cord and indoor/outdoor connecting wires, and remove the back panel.
- (3) Recover gas from the refrigerant circuit.
NOTE: Recover gas from the pipes until the pressure gauge shows 0 PSIG.
- (4) Disconnect the outdoor control P.C. board connectors: CNF1, CNTH1, CNTH2, CN63H, CN712, CN791, CN792, CN793 (**MXZ-3D, MXZ-4D**), CN794 (**MXZ-3D, MXZ-4D**)
- (5) Remove all the screws fixing the electrical parts, and remove the electrical parts.
- (6) Remove the propeller fan.
- (7) Remove all the screws fixing the separator, and remove the separator.
- (8) Remove the sound proof felt.
- (9) Remove the terminal cover, and remove thermal protector (TRS) (Photo 18).
- (10) Disconnect the compressor lead wire from the terminal of the compressor (U, V, W).
- (11) Detach all the brazed parts of the compressor suction and discharge pipes (Photo 19).
- (12) Remove all the compressor nuts and remove the compressor (Photo 19).
- (13) Detach all the brazed parts of 4-way valve and pipes.

NOTE: Be careful not to expose the fusible plug to the braze torch flame or transfer heat to it. The temperature of the fusible plug must not become 140°F (60°C) or higher while working. Protect the fusible plug with a wet cloth when necessary.
(The fusible plug breaks at 158°F [70°C]).

PHOTOS/FIGURES

Photo 18

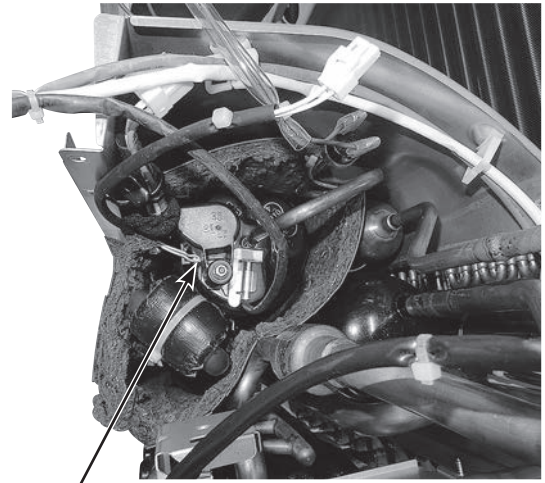

Thermal protector

6. Removing the expansion valve

NOTE: Gas recovery is not required if the unit is pumped down.

- (1) Remove the top panel and the service panel (Refer to section 1).
- (2) Disconnect the power supply cord and indoor/outdoor connecting wires.
- (3) Remove all the LEV coils.
NOTE: When reassembling, to secure the LEV coils on the pipe, make sure to use the metal clips for proper positioning.
- (4) Detach all the brazed parts of the expansion valves and pipes.

Photo 19

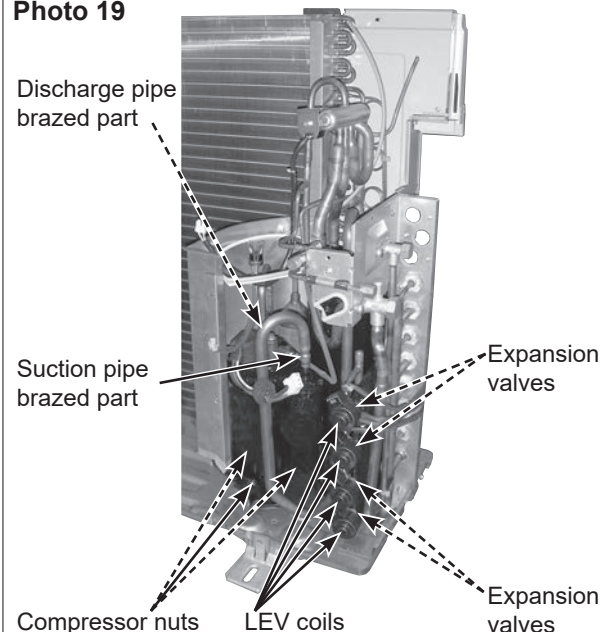

13-3. MXZ-5D36NL MXZ-5D42NL MXZ-3D24NLHZ MXZ-3D30NLHZ

NOTE: Turn OFF the power supply before disassembly.

Photos: MXZ-5D36NL

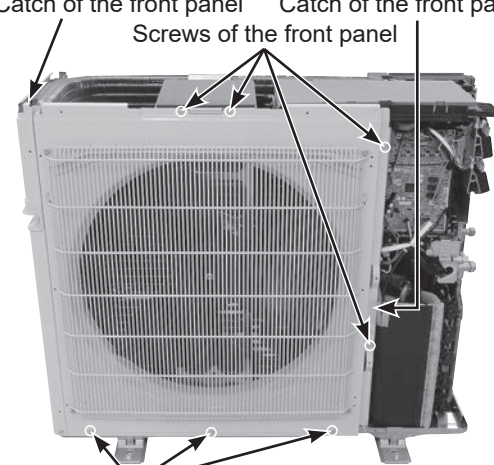
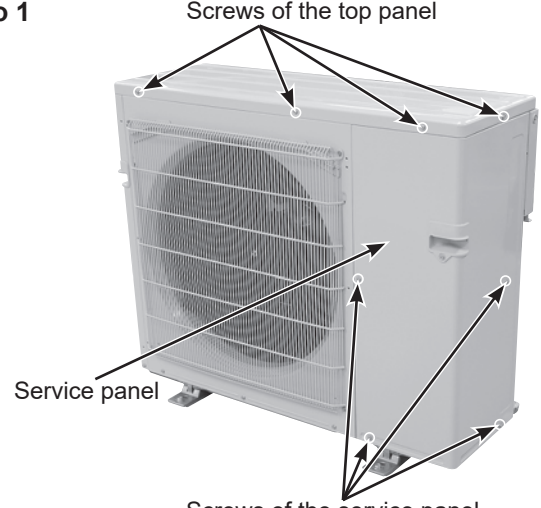
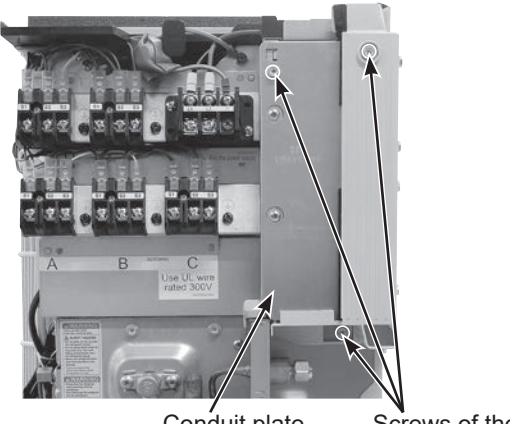
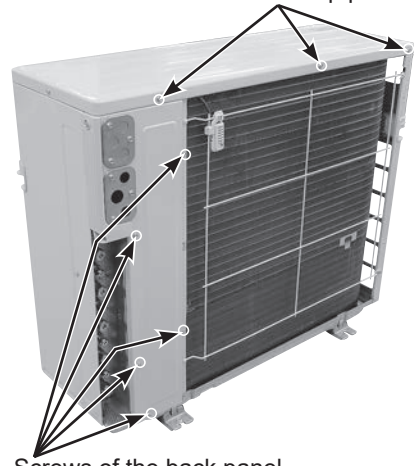
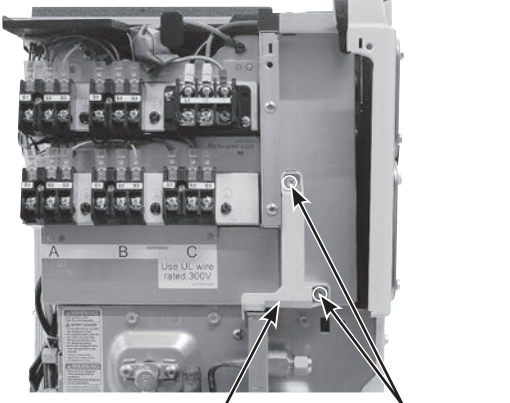
OPERATING PROCEDURE	PHOTOS/FIGURES
<p>1. Removing the panels</p> <ol style="list-style-type: none"> (1) Remove all the screws fixing the top panel, and remove the top panel. (2) Remove all the screws fixing the service panel. (3) Pull down on the service panel, and remove the service panel. (4) Remove all the screws fixing the conduit panel, and remove the conduit panel. (5) Remove all the screws fixing the cable guide, and remove the cable guide. (6) Disconnect the power supply cord and indoor/outdoor connecting wires. (7) Remove all the screws fixing the front panel, and remove the front panel. (8) Remove all the screws fixing the back panel, and remove the back panel. 	<p>Photo 3</p>  <p>Catch of the front panel Catch of the front panel Screws of the front panel</p> <p>Screws of the front panel</p>
<p>Photo 1</p>  <p>Screws of the top panel</p> <p>Service panel</p> <p>Screws of the service panel</p>	<p>Photo 4</p>  <p>Conduit plate</p> <p>Screws of the conduit plate</p>
<p>Photo 2</p>  <p>Screws of the top panel</p> <p>Screws of the back panel</p>	<p>Photo 5</p>  <p>Cable guide</p> <p>Screws of the cable guide</p>

OPERATING PROCEDURE

2. Removing the outdoor control P.C. board, the reactor, the outdoor power P.C. board, and the heatsink

- (1) Remove the top panel, the service panel, conduit panel and cable guide (Refer to section 1).
- (2) Disconnect the power supply cord and indoor/outdoor connecting wires.
- (3) Disconnect the wire-to-wire connector of the compressor lead wire (Photo 6).
- (4) Disconnect all the connectors on the outdoor control P.C. board.
- (5) Remove the releasable cable tie securing the lead wires of core, TBE1, CNTH2, and CNAC2 (Photo 6).
- (6) Remove all the screws fixing the outdoor control P.C. board holder (Photo 6).
- (7) Remove the lead wires of TBE1, CNTH2, and CNAC2 from the right hook on the top of the outdoor control P.C. board holder (Photo 6, Ⓐ).
- (8) Remove the lead wires of CN151 and CN152 from the left hooks on the top and the bottom of the outdoor control P.C. board holder (Photo 6, Ⓑ and 7).
- (9) Remove the outdoor control P.C. board holder.
- (10) Disengage all the catches of the outdoor control P.C. board holder, and remove the outdoor control P.C. board (Photo 8).
- (11) Disconnect all the lead wires from the reactor (Photo 9).
- (12) Remove all the screws fixing the reactor, and remove the reactor (Photo 9).

NOTE: When exchanging the reactor, make sure to exchange all the reactor.

- (13) Remove all the lead wires from the clamps on the separator.

PHOTOS/FIGURES

Photo 8

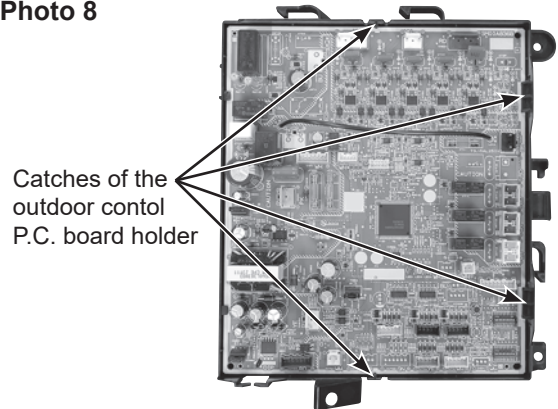

Photo 9

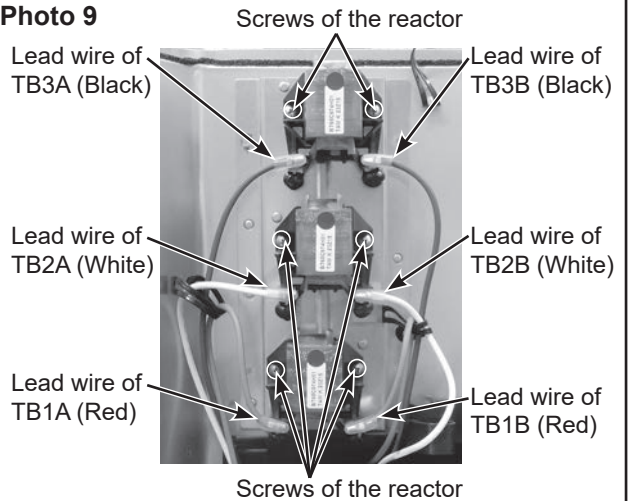

Photo 6

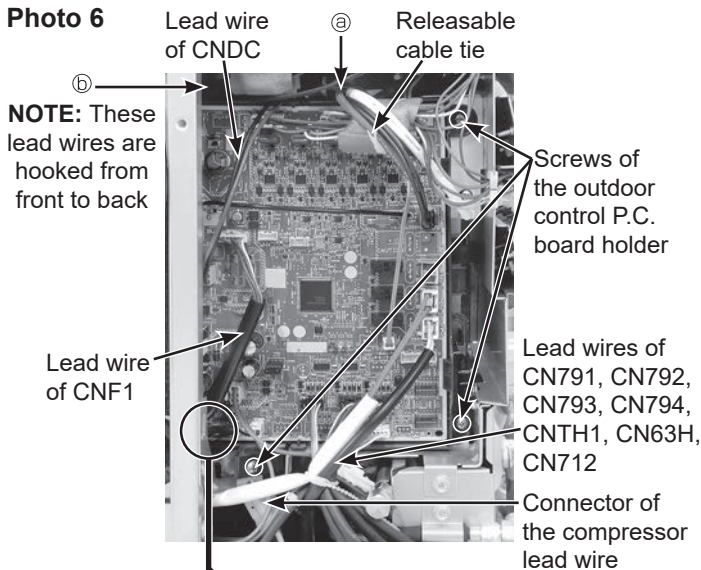
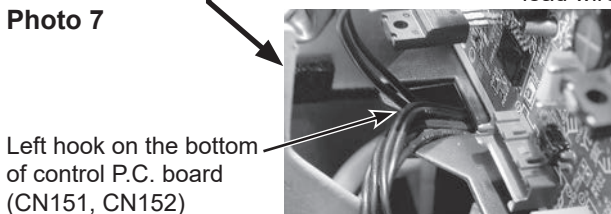

Photo 7



OPERATING PROCEDURE

- (14) Disengage all the catches of the PB cover, and remove the PB cover (Photo 10).
 - (15) Remove the screw fixing the outdoor power P.C. board and all the screws fixing the outdoor power P.C. board and the heatsink (Photo 11).
 - (16) Disengage all the catches of the outdoor power P.C. board, and lift the outdoor power P.C. board (Photo 11).
 - (17) While lifting the outdoor power P.C. board, disconnect the lead wires, the connectors, and the earth wires; then remove the outdoor power P.C. board (Photo 12).
- NOTE:** When reassembling, pass the lead wire of the CN171 through the notch and behind the lead wire of the compressor (Photo 13).
- (18) Remove all the screws of the heatsink fixing parts and remove the heatsink fixing parts (Photo 14).
 - (19) Remove the heatsink.

PHOTOS/FIGURES

Photo 10

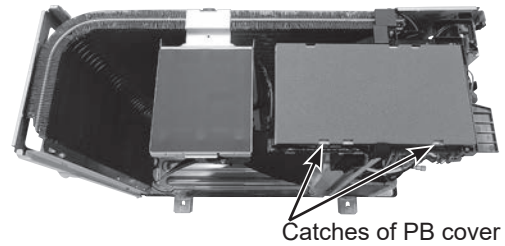

Photo 11

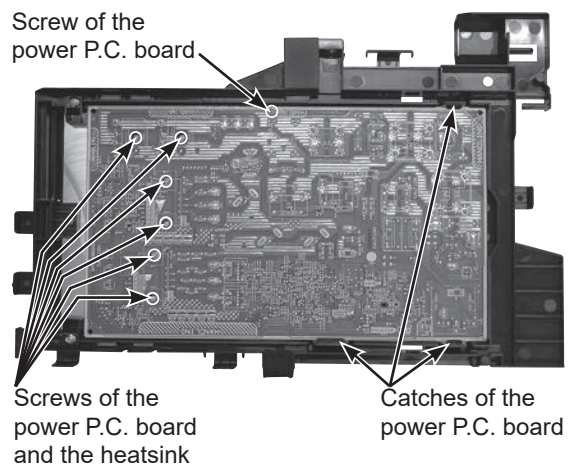
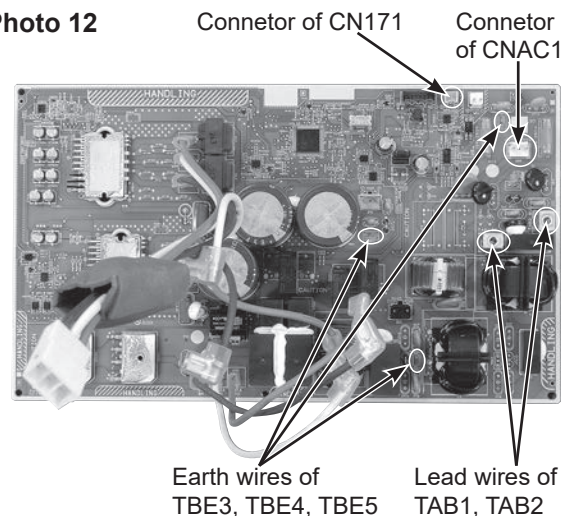
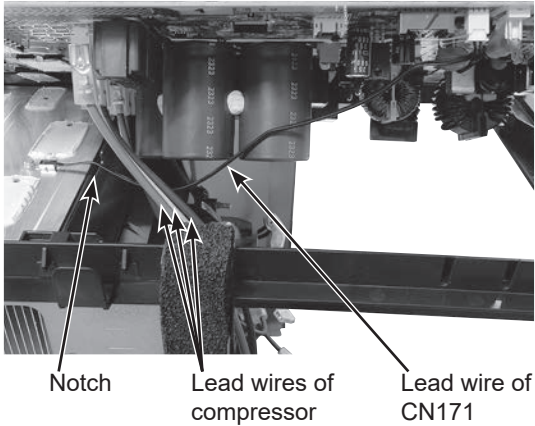

Photo 12



OPERATING PROCEDURE

Photo 13



PHOTOS/FIGURES

Photo 14

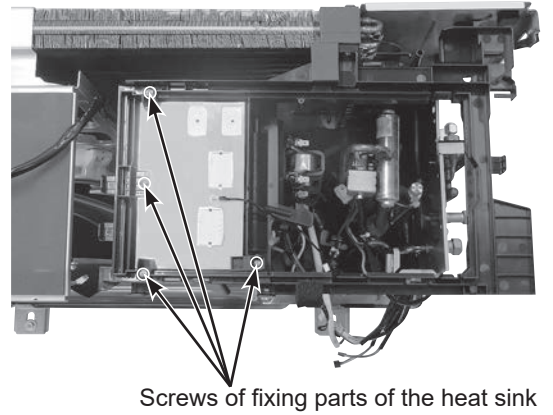

3. Removing the fan motor

- (1) Remove the top panel, the service panel, conduit panel and cable guide (Refer to section 1).
- (2) Disconnect the power supply cord and indoor/outdoor connecting wires.
- (3) Disconnect the connector of CNF1 on the outdoor control P.C. board.
- (4) Remove the propeller fan.
- (5) Remove the fan motor.

NOTE: The propeller fan nut is a reverse thread.

Photo 15

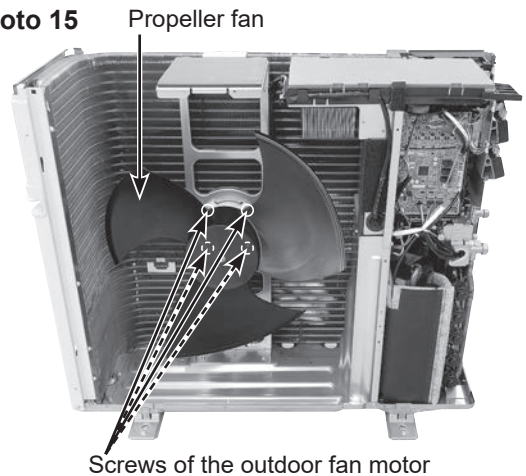

OPERATING PROCEDURE

4. Removing the fusible plug (the 4-way valve assembly)

- (1) Remove the top panel, the service panel, conduit panel and cable guide (Refer to section 1).
- (2) Disconnect the power supply cord and indoor/outdoor connecting wires, and remove the back panel.
- (3) Recover gas from the refrigerant circuit.

NOTE: Recover gas from the pipes until the pressure gauge shows 0 PSIG.

- (4) Disconnect the outdoor control P.C. board connectors: CNF1, CNTH1, CNTH2, CN63H, CN712, CN713, CN714 (**MXZ-3D**), CN791, CN792, CN793, CN794 (**MXZ-5D**), CN795 (**MXZ-5D**).

- (5) Remove all the screws fixing the electrical parts, and remove the electrical parts (Photo 16).

- (6) Remove the propeller fan.

- (7) Remove all the screws fixing the separator, and remove the separator.

NOTE: When installing the separator, insert the tabs of the heat exchanger into the separator.

- (8) Remove all the sound proof felts.

- (9) Remove the screws of the 4-way valve assembly and detach the brazed part of the 4-way valve assembly (including fusible plug) (Photo 17).

NOTE 1: Be careful not to expose the fusible plug to the braze torch flame or transfer heat to it. The temperature of the fusible plug must not become 140°F (60°C) or higher while working. Protect the fusible plug with a wet cloth when necessary. (The fusible plug breaks at 158°F [70°C]). (Photo 18)

NOTE 2: After attaching the 4-way valve assembly, be sure to attach a rubber mount below the fusible plug. Make sure that the rubber mount touches the flare nut. (Photo 18)

PHOTOS/FIGURES

Photo 16

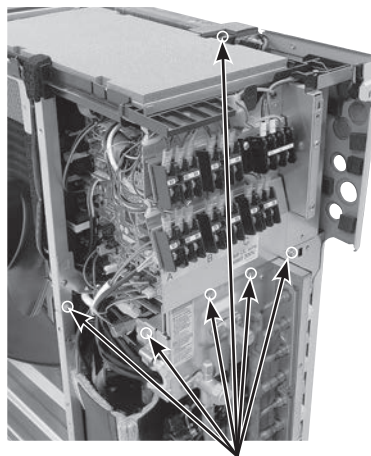

Fixing screws of the electrical parts

Photo 17

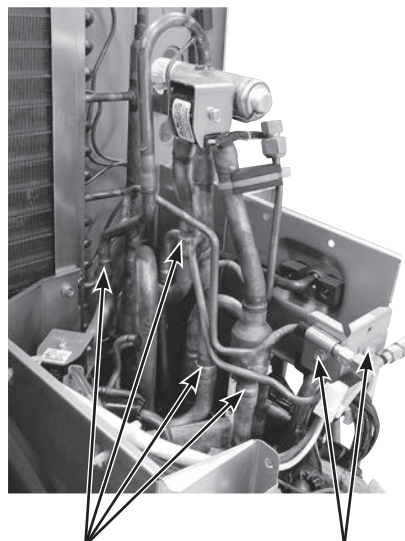

Brazed part of the 4-way valve assembly

Screws of the 4-way valve assembly

Photo 18

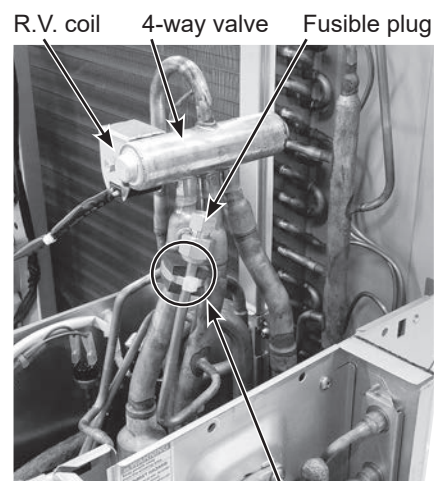

Rubber mount

OPERATING PROCEDURE

5. Removing the compressor and 4-way valve

- (1) Remove the top panel, the service panel, conduit panel and cable guide (Refer to section 1).
- (2) Disconnect the power supply cord and indoor/outdoor connecting wires, and remove the back panel.
- (3) Recover gas from the refrigerant circuit.
NOTE: Recover gas from the pipes until the pressure gauge shows 0 PSIG.
- (4) Disconnect the outdoor control P.C. board connectors: CNF1, CNTH1, CNTH2, CN63H, CN712, CN713, CN714 (**MXZ-3D**), CN791, CN792, CN793, CN794 (**MXZ-5D**), CN795 (**MXZ-5D**).
- (5) Remove all the screws fixing the electrical parts, and remove the electrical parts.
- (6) Remove the propeller fan.
- (7) Remove all the screws fixing the separator, and remove the separator.
- (8) Remove the sound proof felt.
- (9) Remove the terminal cover, and remove thermal protector (TRS) (Photo 19).
- (10) Disconnect the compressor lead wire from the terminal of the compressor (U, V, W).
- (11) Remove the rubber mount and rubber tube attached to the suction pipe.
- (12) Detach all the brazed parts of the compressor suction and discharge pipes (Photo 20).
- (13) Remove all the compressor nuts and remove the compressor (Photo 19).
- (14) Detach all the brazed parts of 4-way valve and pipes.

NOTE: Be careful not to expose the fusible plug to the braze torch flame or transfer heat to it. The temperature of the fusible plug must not become 140°F (60°C) or higher while working. Protect the fusible plug with a wet cloth when necessary. (The fusible plug breaks at 158°F [70°C]).

6. Removing the expansion valve

- NOTE:** Gas recovery is not required if the unit is pumped down.
- (1) Remove the top panel, the service panel, conduit panel and cable guide (Refer to section 1).
 - (2) Disconnect the power supply cord and indoor/outdoor connecting wires.
 - (3) Remove all the LEV coils.
NOTE: When reassembling, to secure the LEV coils on the pipe, make sure to use the metal clips for proper positioning.
 - (4) Detach all the brazed parts of the expansion valves and pipes.

PHOTOS/FIGURES

Photo 19

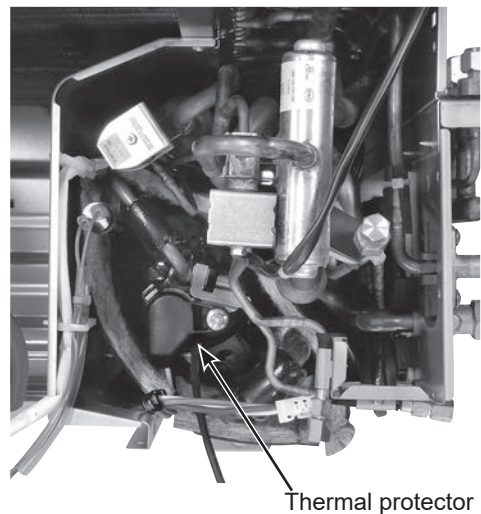
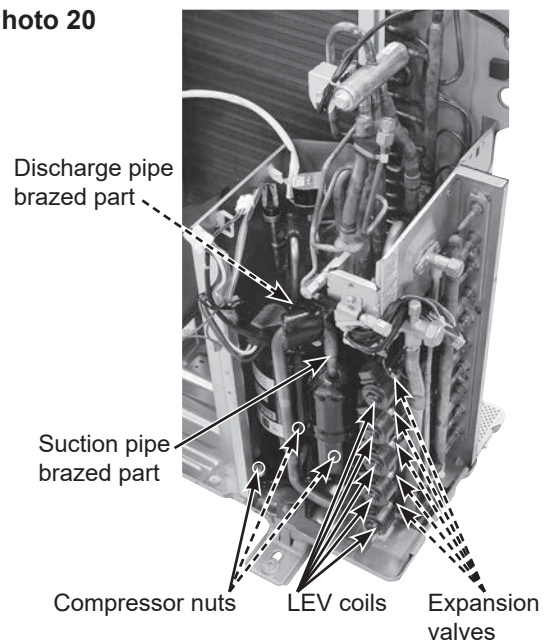

Photo 20



mitsubishi electric corporation

HEAD OFFICE: TOKYO BUILDING, 2-7-3, MARUNOUCHI, CHIYODA-KU, TOKYO 100-8310, JAPAN

© Copyright 2024 MITSUBISHI ELECTRIC CORPORATION

Issued: Nov. 2024. No. OBH949 REVISED EDITION-A

Published: Aug. 2024. No. OBH949

Made in Japan

Specifications are subject to change without notice.