

MICROBLUE™



3 YEAR WARRANTY

PERFORMANCE

17dba

MAX FLOW	MAX HEAD	MAX LIFT
1.3 G/ HOUR	16 FEET	6 FEET

With no additional silencing accessories required, not only is the MicroBlue™ a silent running pump but it can also be mounted in any orientation whilst operating both wet and dry continuously. The MicroBlue™ is a dual voltage pump which uses proven thermistor level sensing technology to remove the risk of stuck or sunken float switches.



SENSING OPTION

MICROBLUE® pump available with:

RESERVOIR	FASCIA KIT
X85-003 (HLA-PACK)	T18-016
	



PUMPS DEBRIS

The MicroBlue™ is the only ductless pump on the market that can remove sediment/debris with no need of filters or regular servicing intervals.



NO SILENCING DEVICES

Smooth flow rate from the MicroBlue™ eliminates the necessity for any pulsating free tubing and silencing devices.

PERFORMANCE

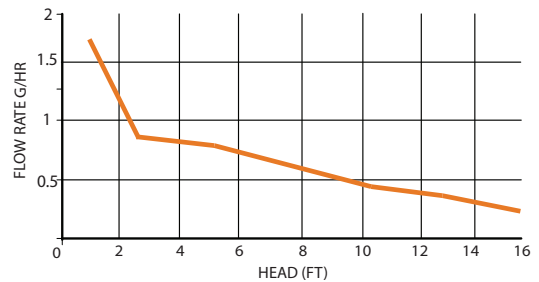

DIMENSIONS (")

CULUS
PLENUM RATED

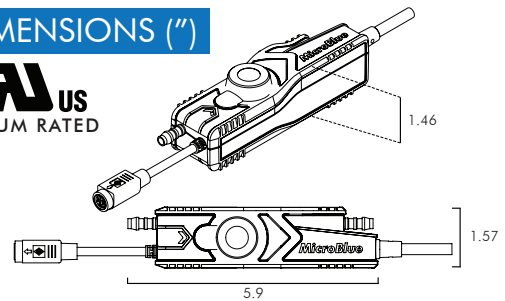

DISCHARGE PIPE RUN



*18000 BTU MAX

V (VERTICAL)	H (HORIZONTAL)
16 FT	0 FT
13 FT	9 FT
9 FT	20 FT
6 FT	30 FT
3 FT	40 FT

The MICROBLUE™ can be mounted in any orientation up to 16FT away from the air conditioning unit.

CONTACT US: +1 770 831 1122

WWW.BLUEDIAMONDPUMP.US

INFO@BLUEDIAMONDPUMP.COM