

PAA-BA30NL
30,000 BTU/H CASSED COIL INDOOR UNIT



Job Name:

System Reference:

Date:



GENERAL FEATURES

- **Furnace Compatible:** Compatible with most gas furnaces, Intelli-HEAT® allows for Intelligent Switchover between the furnace and heat pump operation. *Mitsubishi Electric air-conditioner and heat pump systems should only be connected with ANSI-Z21.47/CSA2.3 certified furnaces
- **Intelligent Switchover:** Intelligent Switchover from electric heat pump to gas furnace operation in extreme cold for consistent comfort. The system can also be set to switch based optimal energy efficiency and to reduce your carbon footprint.
- **High Quality Drain Pan:** High quality drain pan material with high heat tolerance and low moisture absorption
- **Multi-Position Installation:** Versatile installation options, including horizontal (left or right) and vertical (up or down) orientations, with included drain pans to facilitate easy setup for any configuration.
- **Available Widths:** Available in 14.5", 17.5", and 21" widths

SPECIFICATIONS			SYSTEM
UNIT TYPE			PAA-BA30NL
Cooling Capacity (Nominal) ^{1,3}	Cooling Capacity (Nominal)	Btu/h	30000
Heating Capacity (Nominal) ^{2,3}	Heating Capacity (Nominal)	Btu/h	32000
Electrical	Voltage, Phase, Frequency	V AC / V AC , ø , Hz	208 / 230 , 1 , 60
	Voltage: Indoor - Outdoor, S1-S2	V AC	208/230
	Voltage: Indoor - Outdoor, S2-S3	V DC	12-24
	Short-circuit Current Rating [SCCR]	kA	5
Indoor Unit	MCA	A	0.2
	MOCP	A	15
	Rated Airflow, Dry	CFM	875
	Maximum Airflow, Dry	CFM	1024
	Minimum Airflow, Dry	CFM	700
	Internal Static Pressure [at Rated CFM]	in.WG	0.2
	Dual Barrier Coating on Heat Exchanger		No
	Unit Dimensions (W x D x H)	inch x inch x inch [mm x mm x mm]	17-9/16 x 21-7/16 x 27-1/2 [445 x 543 x 697]
	Package Dimensions (W x D x H)	inch x inch x inch [mm x mm x mm]	19-5/16 x 25-5/16 x 33 [491 x 695 x 838]
	Unit Weight [Cased Coil Only]	lbs [kg]	63.9 [29.0]
Control Box Weight	lbs [kg]	5.1 [2.3]	
Package Weight	lbs [kg]	87.1 [39.5]	
Refrigerant	Type		R454B
Piping	Liquid Pipe Size O.D.	inch [mm]	3/8 [9.52]
	Gas Pipe Size O.D.	inch [mm]	5/8 [15.88]
Indoor Unit	Drain Pipe Size O.D.	inch [mm]	3/4 [19.05]

Notes

¹Cooling (Indoor // Outdoor) °F 80 DB, 67 WB // 95 DB, 75 WB - test

²Heating at 47°F (Indoor // Outdoor) °F 70 DB, 60 WB // 47 DB, 43 WB

³Airflow rate 350 CFM per rated ton of cooling at 95°F

*Internal static pressure 0.3 in. WG (According to AHRI Standard - 210/240, where this is the maximum allowable internal static pressure for "Coil Only" systems)

³Nominal capacity only. Actual capacity output varies based on the system specific configuration

INDOOR UNIT ACCESSORIES: PAA-BA30NL

Condensate	Blue Diamond MegaBlue Condensate Pump with Reservoir Sensor 115-230V up to 170k BTU/h	<input type="checkbox"/>	X87-835
	Blue Diamond Sensor Extension Cable 15 Ft	<input type="checkbox"/>	C13-103
	Blue Diamond (MaxiBlue Advanced) Mini Condensate Pump w/ Reservoir & Sensor (110V) up to 48,000 BTU/H [recommended]	<input type="checkbox"/>	X87-711
	Refco Condensate Pump 100-240V up to 120k BTU/h	<input type="checkbox"/>	COMBI
	Sauermann Condensate Pump 120-230V up to 60k BTU/h	<input type="checkbox"/>	SI30-230
	Blue Diamond MaxiBlue Condensate Pump with Reservoir Sensor 115-230V up to 48k BTU/h	<input type="checkbox"/>	X88-721
Control Interface	IT Extender	<input type="checkbox"/>	PAC-WHS01IE-E
	Wireless Interface 2 for Comfrot app	<input type="checkbox"/>	PAC-USWHS002-WF-2
	Procon BACnet® and Modbus® Interface	<input type="checkbox"/>	PAC-UKPRC001-CN-1
	Thermostat Interface	<input type="checkbox"/>	PAC-US446CN-1
	kumo station® for Comfort app	<input type="checkbox"/>	PAC-WHS01HC-E
	Operation and Error Status Output Adapter ¹	<input type="checkbox"/>	PAC-SF40RM-E
Disconnect Switch	30A600VUL fits 2 X 4 utility box - Black	<input type="checkbox"/>	TAZ-MS303
	(30A/600V/UL) [fits 2" X 4" utility box] - White	<input type="checkbox"/>	TAZ-MS303W
Lineset	3/8 x 5/8 Lineset Twin-Tube Insulation - 15 feet	<input type="checkbox"/>	MPLS385812T-15
	3/8 x 5/8 Lineset Twin-Tube Insulation - 50 feet	<input type="checkbox"/>	MPLS385812T-50
	3/8 x 5/8 Lineset Twin-Tube Insulation - 65 feet	<input type="checkbox"/>	MPLS385812T-65
	3/8 x 5/8 Lineset Twin-Tube Insulation - 100 feet	<input type="checkbox"/>	MPLS385812T-100
	3/8 x 5/8 Lineset Twin-Tube Insulation - 10 feet	<input type="checkbox"/>	MPLS385812T-10
	3/8 x 5/8 Lineset Twin-Tube Insulation - 30 feet	<input type="checkbox"/>	MPLS385812T-30
N/A		<input type="checkbox"/>	Unknown
Power Supplies & Auxiliary Components	ERV On/Off Input Adapter for CNER on SVZ PEAD and PVA models	<input type="checkbox"/>	PAC-740
Remote Sensor	Wireless temperature and humidity sensor for Comfrot app	<input type="checkbox"/>	PAC-USWHS003-TH-1
	Wall Mounted Remote Temperature Sensor	<input type="checkbox"/>	PAC-SE41TS-E
	Flush Mount Remote Temperature Sensor for SEZ SLZ SVZ and all P-Series models	<input type="checkbox"/>	PAC-USSEN002-FM-1
Terminal Signal Adapter	3-Pin Wiring Harness	<input type="checkbox"/>	PAC-715AD
	Backup Heat Relay Kit	<input type="checkbox"/>	CN24RELAY-KIT-CM3
	5-Pin Wiring Harness	<input type="checkbox"/>	PAC-725AD
Wired Remote Controller	Simple Direct Wired Remote Controller	<input type="checkbox"/>	PAC-SDW01RC-1
	Deluxe MA Wired Remote Controller	<input type="checkbox"/>	PAR-42MAAUB
	Touch MA Remote Controller	<input type="checkbox"/>	PAR-CT01MAU-SB
	Simple MA Remote Controller	<input type="checkbox"/>	PAC-YT53CRAU-J
Wireless Remote Controller	Wireless RedLINK™ Remote Controller	<input type="checkbox"/>	MHK2
	Universal Wireless Receiver for PAR-FL32MA-E	<input type="checkbox"/>	PAR-FA32MA-W
	Lockdown Bracket for Wireless Handheld Remote Controllers	<input type="checkbox"/>	RCMKP1CB
	Wireless Remote Controller	<input type="checkbox"/>	PAR-SL101A-E
	Universal Wireless Receiver for PAR-FL32MA-E	<input type="checkbox"/>	PAR-FA32MA-E
Notes			

INDOOR UNIT DIMENSIONS: PAA-BA30NL

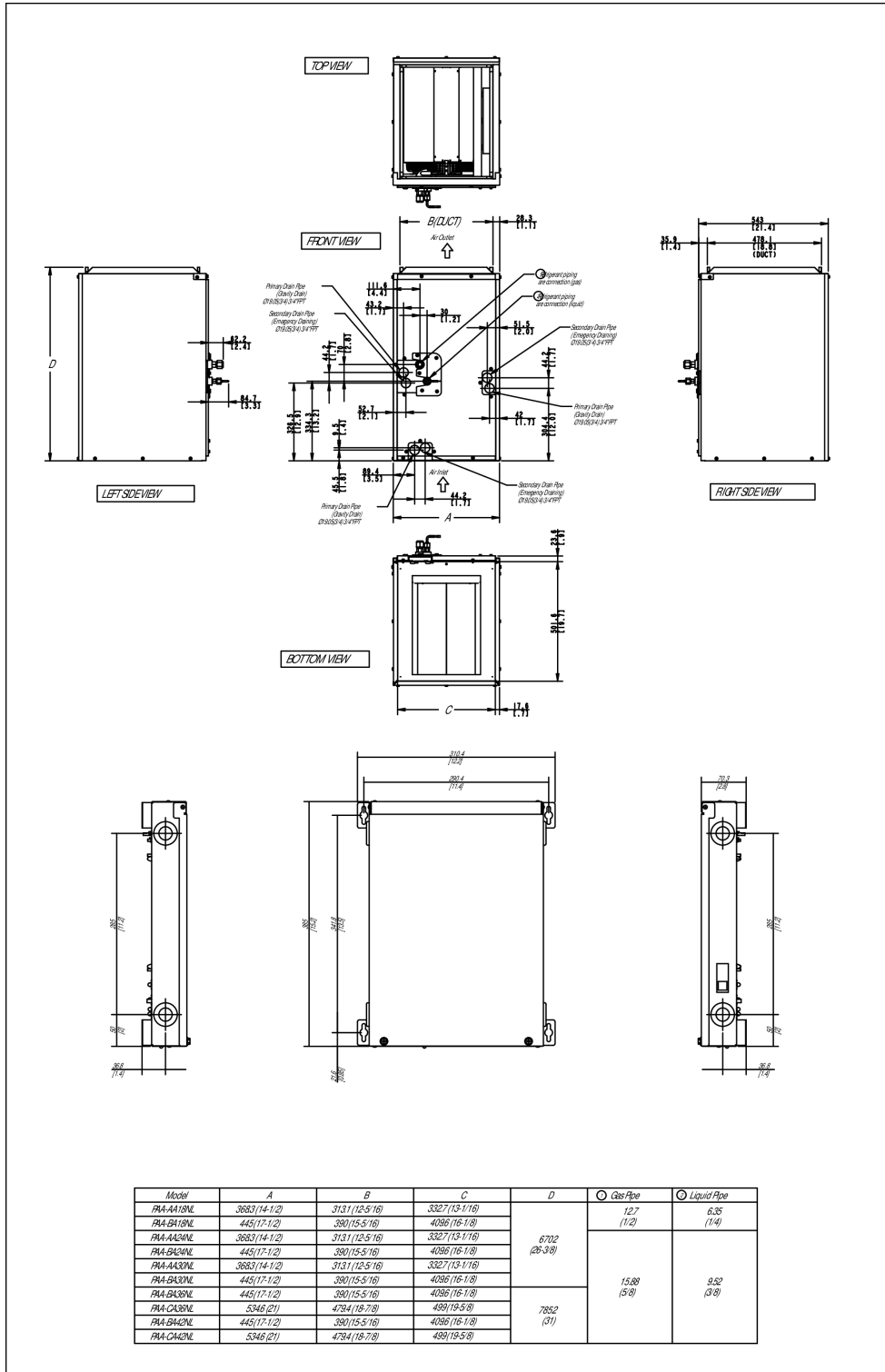

1340 Satellite Boulevard Suwanee, GA 30024
Toll Free: 800-433-4822 · mitsubishicomfort.com