

MFZ-KX18NL & SUZ-AA18NL
18,000 BTU/H FLOOR-MOUNTED INDOOR UNIT
18,000 BTU/H HEAT PUMP OUTDOOR UNIT



Job Name:

System Reference:

Date:



Indoor Unit.....MFZ-KX18NL

Outdoor Unit.....SUZ-AA18NL



INDOOR UNIT FEATURES

- Econo Cool: Temporarily and automatically adjusts the airflow based on heat exchanger temperature. The set temperature is increased slightly, which saves energy, while maintaining comfort.
- Floor front panel access to the filter for ease of cleaning
- Mounts on floor or 5" above floor
- Multi-flow Vane for faster heating
- Multiple control options including: Hand-held Remote Controller (provided with unit), comfort app, third-party interfaces and both wired and wireless controllers
- Multiple fan speed options: Low, Medium, High, Powerful, Auto
- Nano Platinum Filter: This filter has a large capture area and incorporates nanometer-sized platinum-ceramic particles and is designed to reduce the presence of certain nonliving particles, while deodorizing the circulating air.
- Perfect for difficult areas that may be smaller or don't have usable space on the walls
- Powerful Mode: Temporarily drops or raises the set point and fan speed in order to quickly bring the room to the desired temperature.
- Quiet operation: Outdoor units are as quiet as a typical conversation, and most indoor units are whisper quiet.
- Unit can be recessed mounted into wall
- Up and down swing-mode: An indoor unit with this capability can move air up and down throughout the room like an oscillating fan using the horizontal vanes.
- Wi-Fi enabled units pair with the Comfort app for complete control over temperature, fan speeds, modes, schedules, and more.

OUTDOOR UNIT FEATURES

- Blue Fin Coating: An anti-corrosion treatment applied to the aluminum fins of the heat exchanger of the outdoor unit to protect against corrosion caused by salt, sulfur, and other airborne contaminants, especially in coastal and industrial areas.
- High-performance grooved piping: High-performance grooved piping for increased heat exchange efficiency
- Hot-Start Technology: Hot-Start Technology ensures the fan only activates once the heat exchanger is warm, preventing cold air blasts during start-up.
- INVERTER-driven compressor: An inverter-driven compressor generates the precise capacity needed to maintain a temperature set point.
- Joint Lap DC Motor: Innovative Joint Lap DC Motor leads to high efficiency and reliability
- Outdoor unit directed power: The outdoor unit powers the indoor unit, and should a power outage occur, the system is automatically restarted when power returns
- Pulse Amplitude Modulation technology: Pulse Amplitude Modulation technology enhances energy efficiency by adjusting the power supply to optimize compressor performance, ensuring precise capacity control and reduced energy consumption.
- Quiet operation: Quiet operation units are as quiet as a typical conversation, and most indoor units are whisper quiet.
- Single-zone: One outdoor unit connects to one indoor unit to control the comfort in a single space.

SPECIFICATIONS: MFZ-KX18NL & SUZ-AA18NL

Cooling at 95F ¹	Maximum Capacity	Btu/h	18,000	
	Rated Capacity	Btu/h	18,000	
	Minimum Capacity	Btu/h	5,000	
	Maximum Power Input	W	1,450	
	Rated Power Input	W	1,450	
	Moisture Removal	Pints/h	4.1	
	Sensible Heat Factor	-	0.75	
	Power Factor [208V / 230V]	%	98 / 98	
Heating at 47F ²	Maximum Capacity	Btu/h	22,500	
	Rated Capacity	Btu/h	20,000	
	Minimum Capacity	Btu/h	8,400	
	Maximum Power Input	W	2,110	
	Rated Power Input	W	1,690	
	Power Factor [208V / 230V]	%	98 / 98	
Heating at 17F ³	Maximum Capacity	Btu/h	13,400	
	Rated Capacity	Btu/h	13,400	
	Maximum Power Input	W	1,350	
	Rated Power Input	W	1,350	
Heating at 5F ⁴	Maximum Capacity	Btu/h	10,700	
	Maximum Power Input	W	1,045	
Heating at -4F ⁵	Maximum Capacity	Btu/h	8,600	
Efficiency	SEER2		17.2	
	EER2 ¹		12.4	
	HSPF2 [IV]		10.3	
	COP at 47°F ²		3.4	
	COP at 17°F at Maximum Capacity ³		2.9	
	COP at 5°F at Maximum Capacity ⁴		3	
	COP at -4°F at Maximum Capacity ⁵		2.52	
	ENERGY STAR [®] Certified		Yes	
Electrical	Voltage, Phase, Frequency	V AC / V AC, , Hz	208 / 230, 1, 60	
	Guaranteed Voltage Range	V AC	198 - 253	
	Voltage: Indoor - Outdoor, S1-S2	V AC	208/230	
	Voltage: Indoor - Outdoor, S2-S3	V DC	12-24	
	Short-circuit Current Rating [SCCR]	kA	5	
	Recommended Fuse/Breaker Size (Outdoor)	A	30	
	Recommended Wire Size [Indoor - Outdoor]	AWG	14	
	MCA	A	1	
Indoor Unit	Fan Motor Output	W	40	
	Airflow Rate at Cooling, Dry	CFM	198, 254, 328, 420, 491	
	Airflow Rate at Cooling, Wet	CFM	168, 216, 279, 357, 417	
	Airflow Rate at Heating, Dry	CFM	212, 268, 328, 399, 470	
	Sound Pressure Level [Cooling]	dB (A)	28, 33, 39, 45, 50	
	Sound Pressure Level [Heating]	dB (A)	29, 35, 40, 45, 49	
	Dual Barrier Coating on Heat Exchanger		No	
	Unit Dimensions (W x D x H)	inch x inch x inch [mm x mm x mm]	29-1/2 x 8-7/16 x 23-5/8 [750 x 215 x 600]	
	Package Dimensions (W x D x H)	inch x inch x inch [mm x mm x mm]	27-9/16 x 11-3/16 x 32-11/16 [700 x 300 x 830]	
	Unit Weight	lbs [kg]	33 [15]	
	Package Weight	lbs [kg]	40 [18]	
	Fan Motor Type		DC Motor	
	IDU Operating Temp. Range	Cooling Intake Air Temp [Maximum / Minimum]	°FDB, °FWB / °FDB, °FWB	90, 73 / 67, 57
		Heating Intake Air Temp [Maximum / Minimum]	°FDB	80 / 70
NOTES ¹ Cooling at 95°F (Indoor: 80°F DB, 67°F WB // Outdoor: 95°F DB, 75°F WB) ² Heating at 47°F (Indoor: 70°F DB, 60°F WB // Outdoor: 47°F DB, 43°F WB) ³ Heating at 17°F (Indoor: 70°F DB, 60°F WB // Outdoor: 17°F DB, 15°F WB) ⁴ Heating at 5°F (Indoor: 70°F DB, 60°F WB // Outdoor: 5°F DB, 4°F WB) ⁵ Heating at -4°F (Indoor: 70°F DB, 60°F WB // Outdoor: -4°F DB, -5°F WB) * Indoor/Outdoor Unit Operating Temperature Range (Cooling Air Temp [Maximum / Minimum]): • Applications should be restricted to comfort cooling only; equipment cooling applications are not recommended for low ambient temperature conditions. ** Outdoor Unit Operating Temperature Range (Cooling Thermal Lock-out / Re-start Temperatures; Heating Thermal Lock-out / Re-start Temperatures): • System cuts out in heating mode and automatically restarts at these temperatures.				

SPECIFICATIONS: MFZ-KX18NL & SUZ-AA18NL

Outdoor Unit	MCA	A	25
	MOCP	A	42
	Fan Motor Output	W	50
	Airflow Rate Cooling	CFM	2,193
	Airflow Rate Heating	CFM	1,949
	Defrost Method		Reverse Cycle
	Coating on Heat Exchanger (Bluefin, Sea Coast)		Yes, Yes
	Sound Pressure Level, Cooling ¹	dB (A)	54
	Sound Pressure Level, Heating ²	dB (A)	55
	Compressor Type		Twin Rotary
	Compressor Model		SRB172FQHMT
	Compressor Oil [Type // Charge]	Type // oz	RM68EH // 14.54
	External Finish Color		Munsell No.3Y 7.8/1.1
	Base Pan Heater		Optional
	Unit Dimensions (W x D x H)	inch x inch x inch [mm x mm x mm]	33-1/16 x 13 x 34-5/8 [840 x 330 x 880]
	Package Dimensions (W x D x H)	inch x inch x inch [mm x mm x mm]	38-5/8 x 16-9/16 x 39 [980 x 420 x 990]
	Unit Weight	lbs [kg]	115 [52.16]
	Package Weight	lbs [kg]	133 [60.33]
	ODU Operating Temp. Range	Cooling Intake Maximum Air Temp [Maximum / Minimum*]	°FDB
Cooling Thermal Lock-out / Re-start Temperatures**		°FDB	-1 / 3
Heating Air Temp [Maximum / Minimum]		°FDB, °FWB / °FDB, °FWB	75, 65 / -4, -5
Heating Thermal Lock-out / Re-start Temperatures**		°FDB	-14 / -4
Refrigerant	Type		R454B
	Pre-Charged Refrigerant Amount	lbs	3
	Maximum Pre-Charged Piping Length	ft [m]	25 [7.60]
	Additional Refrigerant Charge Per Additional Piping Length	oz/ft	0.22
Piping	Gas Pipe Size O.D. [Flared]	inch [mm]	1/2 [12.72]
	Liquid Pipe Size O.D. [Flared]	inch [mm]	1/4 [6.35]
	Maximum Piping Length	ft [m]	100 [30.48]
	Maximum Height Difference	ft [m]	50 [15.24]
	Maximum Number of Bends		10
NOTES ¹ Cooling at 95°F (Indoor: 80°F DB, 67°F WB // Outdoor: 95°F DB, 75°F WB) ² Heating at 47°F (Indoor: 70°F DB, 60°F WB // Outdoor: 47°F DB, 43°F WB) ³ Heating at 17°F (Indoor: 70°F DB, 60°F WB // Outdoor: 17°F DB, 15°F WB) ⁴ Heating at 5°F (Indoor: 70°F DB, 60°F WB // Outdoor: 5°F DB, 4°F WB) ⁵ Heating at -4°F (Indoor: 70°F DB, 60°F WB // Outdoor: -4°F DB, -5°F WB) * Indoor/Outdoor Unit Operating Temperature Range (Cooling Air Temp [Maximum / Minimum]): • Applications should be restricted to comfort cooling only; equipment cooling applications are not recommended for low ambient temperature conditions. ** Outdoor Unit Operating Temperature Range (Cooling Thermal Lock-out / Re-start Temperatures; Heating Thermal Lock-out / Re-start Temperatures): • System cuts out in heating mode and automatically restarts at these temperatures.			

INDOOR UNIT ACCESSORIES: MFZ-KX18NL

Control Interface	Airzone Wired Blueface Controller Black	AZZBSBLUEZEROCN
	Airzone Wired Blueface Controller White	AZZBSBLUEZEROCB
	Airzone Wireless Lite Controller Black	AZZBSLITERN
	Airzone Wireless Lite Controller White	AZZBSLITERB
	Airzone Wireless Think Controller Black	AZZBSTHINKRN
	Airzone Wireless Think Controller White	AZZBSTHINKRB
	IT Extender for kumo station	PAC-WHS01IE-E
	kumo station for the Comfort app	PAC-WHS01HC-E
	M-Net I/O Control Interface for M-Series ²	MAC-334IF-E
	Procon BACnet and Modbus Interface	PAC-UKPRC001-CN-1
	Thermostat Interface for 3rd Party Thermostats	PAC-US445CN-1
	Wireless Interface Adapter for the Comfort app	PAC-USWHS002-WF-2
	Remote Sensor	Remote Temperature Sensor for MFZ MLZ and MSZ models
Wireless temperature and humidity sensor for the Comfort app		PAC-USWHS003-TH-1
Wired Remote Controller	Deluxe Wired MA Remote Controller ¹	PAR-42MAAUB
	Simple Direct Wired Remote Controller	PAC-SDW01RC-1
	Simple MA Remote Controller ¹	PAC-YT53CRAU-J
	Touch MA Wired Remote Controller ¹	PAR-CT01MAU-SB
Filter	Anti-allergy Enzyme Filter	MAC-408FT-E
Condensate	Blue Diamond Advanced Mini Condensate Pump w Reservoir Sensor 208230V recommended	X87-721
	Blue Diamond MaxiBlue Advanced Mini Condensate Pump w Reservoir Sensor 110V up to 48000 BTUH recommended	X87-711
	Blue Diamond MegaBlue Advanced Condensate Pump w Reservoir Sensor	X87-835
	Blue Diamond MicroBlue Mini Condensate Pump 110208230V up to 18000 BTUH	X86-003
	Blue Diamond Sensor Extension Cable 15 Ft	C13-103
	Refco Condensate Pump 100-240 VAC up to 120000 BTUH	COMBI
	Sauermann Condensate Pump	SI30-230
Power Supplies and Auxiliary Components	Backup Heat Relay Kit Adapter for CN24 or CN152 Connector	CN24RELAY-KIT-CM3
Lineset	100 x 1/4 x 100 1/2 Lineset Twin-Tube Insulation	MLS141212T-100
	15 x 1/4 x 15 1/2 Lineset Twin-Tube Insulation	MLS141212T-15
	30 x 1/4 x 30 1/2 Lineset Twin-Tube Insulation	MLS141212T-30
	50 x 1/4 x 50 1/2 Lineset Twin-Tube Insulation	MLS141212T-50
	65 x 1/4 x 65 1/2 Lineset Twin-Tube Insulation	MLS141212T-65
Wireless Remote Controller	Lockdown Bracket for Wireless Handheld Remote Controllers	RCMKP1CB
	RedLINK Wireless Remote Controller	MHK2
Floor Mount Air Guide	Floor Mount Air Guide	MAC-760FD-E
Disconnect Switch	30A600VUL fits 2 X 4 utility box - Black	TAZ-MS303
	30A600VUL fits 2 X 4 utility box - White	TAZ-MS303W
Drain Hose	Flexible Mini-Split Drain Hose	DRX-16
<p>NOTES</p> <p>²Allows IDU Connection to MA Controller: Deluxe MA Remote Controller Simple MA Controller Touch MA Controller ¹Requires MAC-334IF-E Adapter ¹Requires MAC-334IF-E Adapter ¹Requires MAC-334IF-E Adapter</p>		

OUTDOOR UNIT ACCESSORIES: SUZ-AA18NL

Optional Defrost Heater	Base Heater	MAC-660BH-U
	Base Heater	MAC-642BH-U1
Stand	18 Single Fan Stand	QSMS1801M
	24 Single Fan Stand	QSMS2401M
	Condenser Wall Bracket	QSWB2000M-1
	Condenser Wall Bracket - Stainless Steel Finish	QSWBSS
	Outdoor Unit 3-14 inch Mounting Base Pair - Plastic	DSD-400P
	Outdoor Unit Stand 12 High	QSMS1201M
Muffler	Muffler for Connection to MFZ-KX	MAC-002MF-E
Mini-Split Wire	14 Gauge 4 wire Armored MiniSplit Cable250 ft roll	SW144-250
	14 Gauge 4 wire Armored MiniSplit Cable50 ft roll	SW144-50
	14 Gauge 4 wire MiniSplit Cable250 ft roll	S144-250
	14 Gauge 4 wire MiniSplit Cable50 ft roll	S144-50
Air Outlet Guide	Air Outlet Guide	MAC-886SG-E
Drain Socket	Drain Socket	MAC-871DS
Control/Service Tool	M- & P-Series Maintenance Tool Cable Set	M21EC0397
	Maintenance Tool Interface	PAC-USCMS-MN-1
Mounting Pad	Condensing Unit Mounting Pad 16 x 36 x 3	ULTRILITE1
Snow/Rain Diverter	SnowRain Diverter	SRD-3
NOTES		

INDOOR UNIT DIMENSIONS: MFZ-KX18NL

MFZ-KX09NL- U1
 MFZ-KX12NL- U1
 MFZ-KX15NL- U1
 MFZ-KX18NL- U1

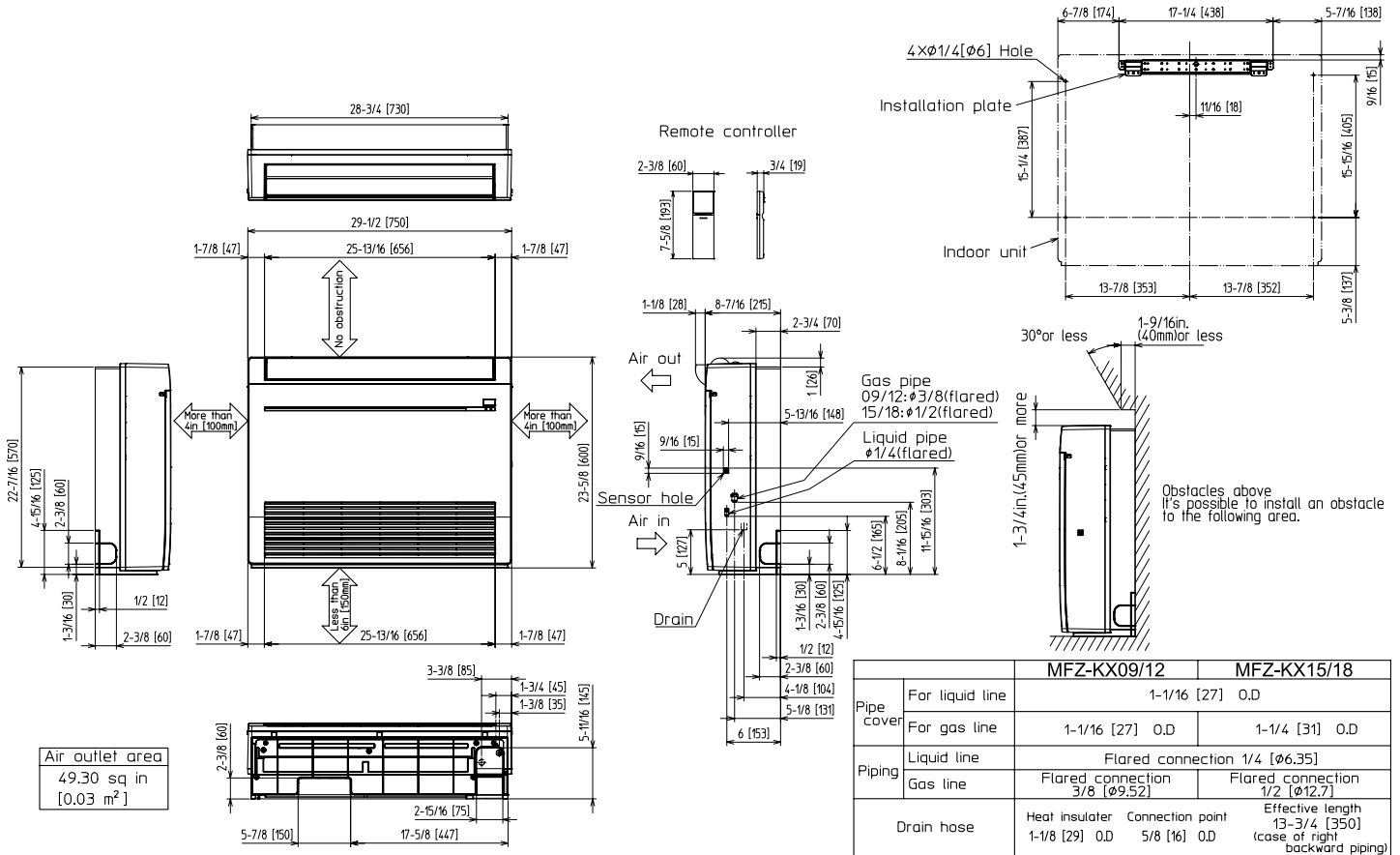

OUTDOOR UNIT DIMENSIONS: SUZ-AA18NL

REQUIRED SPACE

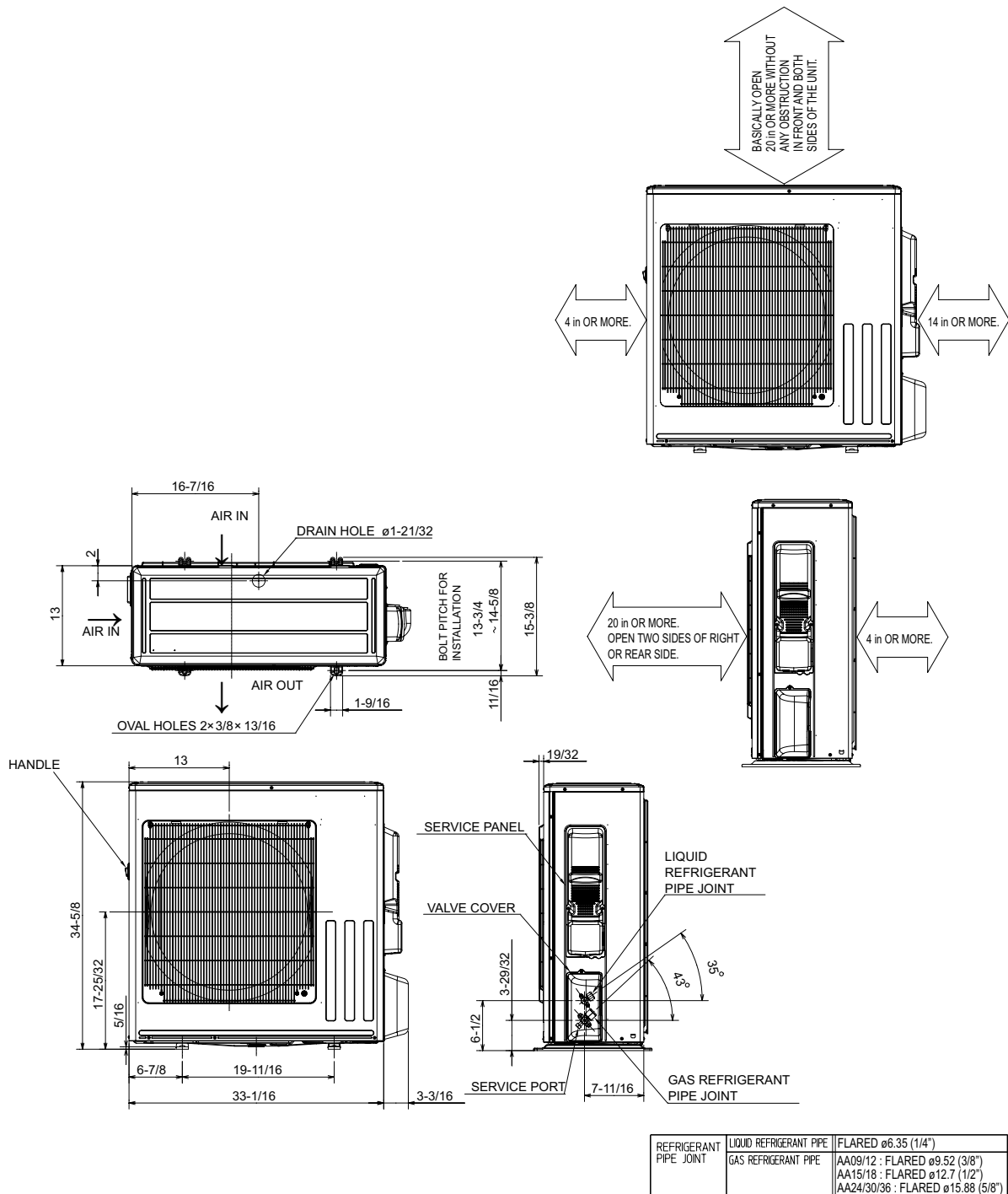

1340 Satellite Boulevard Suwanee, GA 30024
Toll Free: 800-433-4822 <https://mitsubishicomfort.com>