

MBVB***P1X00

BLOWER CABINET

INSTALLATION INSTRUCTIONS

© 2026

Daikin Comfort Technologies Manufacturing, Inc.

19001 Kermier Rd., Waller, TX 77484

www.goodmanmfg.com - www.amana-hac.com

P/N: IO-456F Date: January 2026

QUEBEC DISCLOSURE REGARDING AVAILABILITY OF REPLACEMENT PARTS, REPAIR SERVICES AND INFORMATION FOR MAINTENANCE AND REPAIR: DAIKIN COMFORT TECHNOLOGIES MANUFACTURING, INC. (DAIKIN) DOES NOT GUARANTEE THE AVAILABILITY OF (1) REPLACEMENT PARTS; (2) REPAIR SERVICES; AND (3) INFORMATION NECESSARY TO MAINTAIN OR REPAIR PRODUCTS, WITHIN THE MEANING OF SECTION 39.1 OF THE CONSUMER PROTECTION ACT, CQLR, c P-40.1 AND SECTION 79.18 OF THE REGULATION RESPECTING THE APPLICATION OF THE CONSUMER PROTECTION ACT, CQLR, c P-40.1, R. 3.

AVIS POUR LE QUÉBEC CONCERNANT LA DISPONIBILITÉ DES PIÈCES DE RECHANGE, DES SERVICES DE RÉPARATION ET DES RENSEIGNEMENTS POUR L'ENTRETIEN ET LA RÉPARATION : DAIKIN COMFORT TECHNOLOGIES MANUFACTURING, INC. (DAIKIN) NE GARANTIT PAS LA DISPONIBILITÉ (1) DES PIÈCES DE RECHANGE, (2) DES SERVICES DE RÉPARATION ET (3) DES RENSEIGNEMENTS POUR L'ENTRETIEN ET LA RÉPARATION, AU SENS DE L'ARTICLE 39.1 DE LA LOI SUR LA PROTECTION DU CONSOMMATEUR, RLRQ c P-40.1 ET DE L'ARTICLE 79.18 DU RÈGLEMENT D'APPLICATION DE LA LOI SUR LA PROTECTION DU CONSOMMATEUR, RLRQ c P-40.1, R. 3.



WARNING

ONLY PERSONNEL THAT HAVE BEEN TRAINED TO INSTALL, ADJUST, SERVICE, MAINTENANCE OR REPAIR (HEREINAFTER, "SERVICE") THE EQUIPMENT SPECIFIED IN THIS MANUAL SHOULD SERVICE THE EQUIPMENT.

THIS EQUIPMENT IS NOT INTENDED FOR USE BY PERSONS (INCLUDING CHILDREN) WITH REDUCED PHYSICAL, SENSORY OR MENTAL CAPABILITIES, OR LACK OF EXPERIENCE AND KNOWLEDGE, UNLESS THEY HAVE BEEN GIVEN SUPERVISION OR INSTRUCTION CONCERNING USE OF THE APPLIANCE BY A PERSON RESPONSIBLE FOR THEIR SAFETY.

CHILDREN SHOULD BE SUPERVISED TO ENSURE THAT THEY DO NOT PLAY WITH THE EQUIPMENT.

THE MANUFACTURER WILL NOT BE RESPONSIBLE FOR ANY INJURY OR PROPERTY DAMAGE ARISING FROM IMPROPER SUPERVISION, SERVICE OR SERVICE PROCEDURES. IF YOU SERVICE THIS UNIT, YOU ASSUME RESPONSIBILITY FOR ANY INJURY OR PROPERTY DAMAGE WHICH MAY RESULT. IN ADDITION, IN JURISDICTIONS THAT REQUIRE ONE OR MORE LICENSES TO SERVICE THE EQUIPMENT SPECIFIED IN THIS MANUAL, ONLY LICENSED PERSONNEL SHOULD SERVICE THE EQUIPMENT. IMPROPER SUPERVISION, INSTALLATION, ADJUSTMENT, SERVICING, MAINTENANCE OR REPAIR OF THE EQUIPMENT SPECIFIED IN THIS MANUAL, OR ATTEMPTING TO INSTALL, ADJUST, SERVICE OR REPAIR THE EQUIPMENT SPECIFIED IN THIS MANUAL WITHOUT PROPER SUPERVISION OR TRAINING MAY RESULT IN PRODUCT DAMAGE, PROPERTY DAMAGE, PERSONAL INJURY OR DEATH.

This device, which was assembled by Daikin Comfort Technologies Manufacturing, Inc., contains a component that is classified as an intentional radiator. This intentional radiator has been certified by the FCC: FCC ID QOQBGM111. And this international radiator has an Industry Canada ID: IC 5123A-BGM111.

This device complies with Part 15 of the FCC's Rules. Operation of this device is subject to two conditions:

- (1) This device may not cause harmful interference; and
- (2) This device must accept any interference received, including interference that may cause undesirable operation.

And this device meets the applicable Industry Canada technical specifications.

The manufacturer of the intentional radiator (model no. BGM111) is Silicon Laboratories Finland Oy, which can be contacted by calling 617-951-0200. (www.silabs.com)

The FCC responsible party is Daikin Comfort Technologies Manufacturing, Inc., and may be contacted by calling (713)-816-2500, or at 19001 Kermier Rd., Waller, TX 77484. (www.daikincomfort.com)

This equipment complies with FCC radiation exposure limits. To ensure compliance, human proximity to the antenna shall not be less than 20cm during normal operations.

Changes or modifications not expressly approved by the party responsible for compliance could void the user's authority to operate the equipment.



WARNING

DO NOT BYPASS SAFETY DEVICES.



is a registered trademark of Maytag Corporation or its related companies and is used under license. All rights reserved.



CONTENTS

INTRODUCTION.....	2
ELECTROSTATIC DISCHARGE (ESD) PRECAUTIONS	2
CHECKING PRODUCT RECEIVED.....	2
REPLACEMENT PARTS.....	2
ORDERING PARTS	2
IMPORTANT SAFETY INSTRUCTIONS	3
RECOGNIZE SAFETY SYMBOLS, WORDS, AND LABELS	3
GENERAL INFORMATION.....	4
FEATURES.....	4
ACHIEVING LESS AIR LEAKAGE.....	4
CLEARANCES AND ACCESSIBILITY	4
INSULATION	4
INSTALLATION INSTRUCTIONS	4
BLOWER WITH CASED EVAPORATOR COIL INSTALLATION.....	4
UPFLOW INSTALLATION	4
COUNTERFLOW INSTALLATION	5
HORIZONTAL INSTALLATION	5
COUNTERFLOW AND HORIZONTAL APPLICATIONS.....	5
ELECTRICAL CONNECTIONS	6
208/230 VOLT LINE CONNECTIONS.....	6
LOW VOLTAGE WIRING.....	6
OPERATION ON 208 VOLT SUPPLY.....	6
24 VOLT THERMOSTAT WIRING	6
COOLCLOUD HVAC PHONE APPLICATION.....	6
QUICK START GUIDE FOR COMMUNICATING OUTDOOR UNITS.....	7
CHARGING INSTRUCTIONS FOR AN INVERTER OUTDOOR UNIT.....	8
CHARGING INSTRUCTIONS FOR A TWO-STAGE OUTDOOR UNIT.....	9
QUICK START GUIDE FOR NON-COMMUNICATING OUTDOOR UNITS..	9
CHARGING	10
ELECTRIC HEAT KIT TESTING	10
DEHUMIDIFICATION	10
AUXILIARY ALARM SWITCH	12
7-SEGMENT DISPLAY AND PUSH BUTTONS.....	12
ACCESSORY CONTROL	12
DEHUMIDIFICATION CONTROL OPTIONS	12
RAMPING PROFILES	12
ELECTRIC AIR CLEANER	13
TROUBLESHOOTING	13
TROUBLESHOOTING MATRIX.....	14
PUSH BUTTON MENUS	16
SYSTEM STATUS DISPLAY.....	18
AIRFLOW LABEL	19
WIRING DIAGRAM.....	20
HOMEOWNERS ROUTINE MAINTENANCE RECOMMENDATIONS....	21
START UP CHECKLIST.....	22

THIS PRODUCT CONTAINS ELECTRONIC COMPONENTS WHICH REQUIRE A DEFINITE GROUND. PROVISIONS ARE MADE FOR CONNECTION OF THE GROUND. A DEDICATED GROUND FROM THE MAIN POWER SUPPLY OR AN EARTH GROUND MUST BE PROVIDED.

INTRODUCTION

This booklet contains the installation and operating instructions for your modular blower cabinet. All warnings and precautions within this booklet must be observed. Improper installation can result in problems ranging from noisy operation to property or equipment damages, dangerous conditions that could result in injury or personal property damage and that are not covered by the warranty. Read this booklet and any instructions packaged with accessories prior to installation. Give this booklet to the user and explain its provisions. The user should retain this booklet for future reference.

ELECTROSTATIC DISCHARGE (ESD) PRECAUTIONS

NOTE: Discharge body's static electricity before touching unit. An electrostatic discharge can adversely affect electrical components.

Use the following precautions during modular blower installation and servicing to protect the integrated control module from damage. By putting the modular blower, the control, and the person at the same electrostatic potential, these steps will help avoid exposing the integrated control module to electrostatic discharge. This procedure is applicable to both installed and uninstalled (ungrounded) blowers.

1. Disconnect all power to the blower. Do not touch the integrated control module or any wire connected to the control prior to discharging your body's electrostatic charge to ground.
2. Firmly touch a clean, unpainted, metal surface of the modular blower near the control. Any tools held in a person's hand during grounding will be discharged.
3. Service integrated control module or connecting wiring following the discharge process in step 2. Use caution not to recharge your body with static electricity; (i.e., do not move or shuffle your feet, do not touch ungrounded objects, etc.). If you come in contact with an ungrounded object, repeat step 2 before touching control or wires.
4. Discharge your body to ground before removing a new control from its container. Follow steps 1 through 3 if installing the control on a blower. Return any old or new controls to their containers before touching any ungrounded object.

CHECKING PRODUCT RECEIVED

Upon receiving the unit, inspect it for damage from shipment. Claims for damage, either shipping or concealed, should be filed immediately with the shipping company. Check the unit model number, specifications, electrical characteristics and accessories to determine if they are correct. In the event an incorrect unit is shipped, it must be returned to the supplier and must NOT be installed. The manufacturer assumes no responsibility for installation of incorrectly shipped units.

REPLACEMENT PARTS

ORDERING PARTS

When reporting shortages or damages, or ordering repair parts, give the complete unit model and serial numbers as stamped on the unit's nameplate.

Replacement parts for this appliance are available through your contractor or local distributor. For the location of your nearest distributor contact:

HOMEOWNER SUPPORT

DAIKIN COMFORT TECHNOLOGIES MANUFACTURING, INC.

19001 KERMIER ROAD

WALLER, TEXAS 77484

(877) 254-4729

IMPORTANT SAFETY INSTRUCTIONS

RECOGNIZE SAFETY SYMBOLS, WORDS, AND LABELS

The following symbols and labels are used throughout this manual to indicate immediate or potential hazards. It is the owner's responsibility to read and comply with all safety information and instructions accompanying these symbols. Failure to heed safety information increases the risk of property damage, product damage, personal injury or death.

	WARNING
HIGH VOLTAGE!	
DISCONNECT ALL POWER BEFORE SERVICING.	
MULTIPLE POWER SOURCES MAY BE PRESENT. FAILURE TO DO SO MAY CAUSE PROPERTY DAMAGE, PERSONAL INJURY OR DEATH.	
	

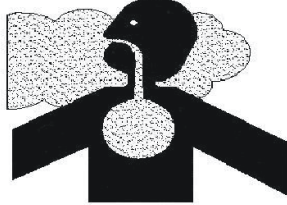
	DANGER PELIGRO
	
CARBON MONOXIDE POISONING HAZARD	
Special Warning for Installation of Furnace or Air Handling Units in Enclosed Areas such as Garages, Utility Rooms or Parking Areas	
Carbon monoxide producing devices (such as an automobile, space heater, gas water heater, etc.) should not be operated in enclosed areas such as unventilated garages, utility rooms or parking areas because of the danger of carbon monoxide (CO) poisoning resulting from the exhaust emissions. If a furnace or air handler is installed in an enclosed area such as a garage, utility room or parking area and a carbon monoxide producing device is operated therein, there must be adequate, direct outside ventilation.	
This ventilation is necessary to avoid the danger of CO poisoning which can occur if a carbon monoxide producing device continues to operate in the enclosed area. Carbon monoxide emissions can be (re)circulated throughout the structure if the furnace or air handler is operating in any mode.	
CO can cause serious illness including permanent brain damage or death. B10259-216	
RIESGO DE INTOXICACIÓN POR MONÓXIDO DE CARBONO	
Advertencia especial para la instalación de calentadores ó manejadoras de aire en áreas cerradas como estacionamientos ó cuartos de servicio.	
Los equipos ó aparatos que producen monóxido de carbono (tal como automóvil, calentador de gas, calentador de agua por medio de gas, etc) no deben ser operados en áreas cerradas debido al riesgo de envenenamiento por monóxido de carbono (CO) que resulta de las emisiones de gases de combustión. Si el equipo ó aparato se opera en dichas áreas, debe existir una adecuada ventilación directa al exterior.	
Esta ventilación es necesaria para evitar el peligro de envenenamiento por CO, que puede ocurrir si un dispositivo que produce monóxido de carbono sigue operando en el lugar cerrado.	
Las emisiones de monóxido de carbono pueden circular a través del aparato cuando se opera en cualquier modo.	
El monóxido de carbono puede causar enfermedades severas como daño cerebral permanente ó muerte. B10259-216	
RISQUE D'EMPOISONNEMENT AU MONOXYDE DE CARBONE	
Avertissement special au sujet de l'installation d'appareils de chauffage ou de traitement d'air dans des endroits clos, tels les garages, les locaux d'entretien et les stationnements.	
Évitez de mettre en marche les appareils produisant du monoxyde de carbone (tels que les automobile, les appareils de chauffage autonome, etc.) dans des endroits non ventilés tels que les d'empoisonnement au monoxyde de carbone. Si vous devez faire fonctionner ces appareils dans un endroit clos, assurez-vous qu'il y ait une ventilation directe provenant de l'exterieur.	
Cette ventilation est nécessaire pour éviter le danger d'intoxication au CO pouvant survenir si un appareil produisant du monoxyde de carbone continue de fonctionner au sein de la zone confinée.	
Les émissions de monoxyde de carbone peuvent être recirculés dans les endroits clos, si l'appareil de chauffage ou de traitement d'air sont en marche.	
Le monoxyde de carbone peut causer des maladies graves telles que des dommages permanents au cerveau et même la mort. B10259-216	

GENERAL INFORMATION

The MBVB Blower Cabinets are used in combination with a cased evaporator coil. This combination of blower and coil functions as the indoor part of a split air-conditioning system, and may be matched with a remote condensing or heat pump unit. The blower cabinet can also function as an electric furnace when used with an electric heater.

NOTE: The electric heating elements for electric furnace installation are not shipped with the cabinet and are field-installed.

Systems should be properly sized by heat gain and loss calculations made according to methods of the Air Conditioning Contractors Association (ACCA) or equivalent. It is the contractor's responsibility to ensure the system has adequate capacity to heat or cool the conditioned space.

FEATURES

This modular blower is a part of the ComfortBridge™ Technology family of products. The Modular Blower can operate as a digitally communicating system requiring only simple 24VAC thermostat inputs to function (Y for cooling, W for heating, G for fan operations). Internal algorithms will provide 2 stage or inverter Air Conditioner or Heat Pump functionality based on these simple inputs. With built-in Bluetooth® operation, the **CoolCloud™** HVAC phone application is available for commissioning, software and shared data updates and troubleshooting. The Modular Blower can support non-communicating outdoor unit installations as well. See wiring sections for more details. The ComfortBridge™ Technology system simplifies wiring, provides enhanced setup features and elevates diagnostics capabilities.

ACHIEVING LESS AIR LEAKAGE:

Ensure all the gaskets remain intact on surfaces as shipped with the unit. Ensure upon installation that the plastic breaker cover is flush with the access panel and access panel is flush with the cabinet. With these requirements satisfied, the unit achieves less airflow leakage when tested in accordance with ASHRE Standard 193.

- Cabinet air leakage less than 2.0% at 1.0 inch H₂O when tested in accordance with ASHRAE standard 193.
- Cabinet air leakage less than 1.4% at 0.5 inch H₂O when tested in accordance with ASHRAE standard 193.

CLEARANCES AND ACCESSIBILITY

The unit can be positioned for upflow, counterflow, horizontal right or horizontal left operation. Zero clearance is allowed on all sides for combustible materials. Thirty-six inches should be allotted on the door side for maintenance and service.

To reduce risk of rusting, do not install the unit directly on the ground or on a floor that is likely to be wet. In such environments, the unit must be elevated by use of a sturdy, nonporous material.

NOTE: This unit should be installed in a manner so that it is not accessible to the public.

INSULATION

To ensure efficient operation, review the following precautions.

- If the unit is located in an area with high ambient temperature and/or high humidity, the air handler may be subject to nuisance sweating of the casing. On these installations, a wrap of 2" fiberglass insulation with a vapor barrier is recommended.
- The factory recommends insulating the duct running through any unconditioned spaces.

To reduce operating sound and vibration transmission use flexible canvas duct connections at the cabinet.

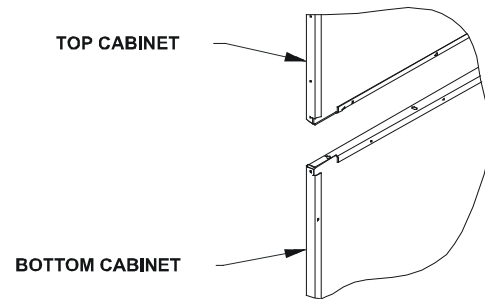

Figure 1 - Coil and Blower Connection

INSTALLATION INSTRUCTIONS

NOTE: This appliance is designed for indoor installation only at max. altitude of 10,500 feet above sea level & a min altitude of -184 feet below sea level.

BLOWER WITH CASSED EVAPORATOR COIL INSTALLATION

Secure the coil and blower together with the two connector plates and screws supplied in the blower bag assembly. Use one connector plate and six screws on each side of the unit.

If accessory electric heat is to be added, install now per the instructions shipped with the heater kit.

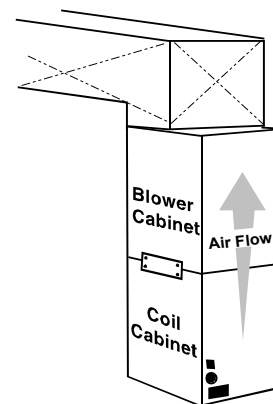

Figure 2 - Upflow Application

UPFLOW INSTALLATION

For upflow installations, the blower cabinet must sit on top of the coil cabinet (Figure 2).

NOTE: All panels should be in place before installing the cabinet.

1. Place the blower and coil cabinet assembly upright on the return duct or duct opening. Ensure that there is ample support for the cabinet assembly and all attached ductwork.
2. Connect refrigerant and condensate drain connections per the evaporator coil installation instructions. Ensure refrigerant and drain lines do not interfere with service access to the unit.
3. Attach supply ductwork. Seal connections between unit and ductwork as required to reduce/eliminate air leakage.
4. Make electrical connections as specified in *Electrical Connections* section of this manual.

COUNTERFLOW INSTALLATION

For counterflow installations, the evaporator coil cabinet must sit on top of the blower cabinet (Figure 3). **NOTE:** All panels should be in place when installing the unit.

NOTE: Supply ductwork for counterflow applications, must be Class I. However, if combustible ductwork is used, sheet metal protection is required.

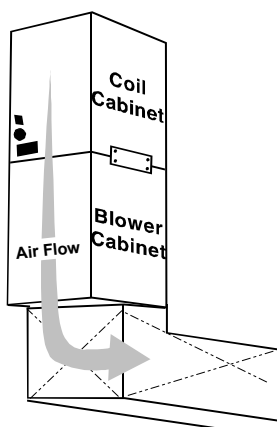

Figure 3 - Counterflow Application

1. Place the blower and coil cabinet assembly supply outlet on the supply duct or duct opening. Ensure there is ample support for the unit and all attached ductwork.
2. Connect refrigerant and condensate drain connections per the evaporator coil installation instructions. Ensure refrigerant and drain lines do not interfere with service access to the unit.
3. Attach return ductwork. Seal connections between unit and ductwork as required to reduce/eliminate air leakage.
4. Make electrical connections as specified in *Electrical Connections* section of this manual.

HORIZONTAL INSTALLATION

For horizontal installations, the coil cabinet must be upstream of the blower cabinet (Figures 4 and 5). **NOTE:** All panels should be in place when installing the unit.

1. Set the unit near its final installation place. The unit must be supported along the entire length of the unit. Rubber isolation pads may be used to reduce sound and vibration transmission. Ensure there is ample support for the unit and all attached ductwork.

NOTE: Unit must be mounted with access panel facing the front as shown in following diagrams.

2. If installed above a finished ceiling or living space, be sure to put a secondary drain pan under the entire unit, and pipe the drain separately from the main condensate drain.
3. Connect refrigerant and condensate drain connections per the coil section installation instructions. Ensure refrigerant and drain lines do not interfere with service access to the unit.

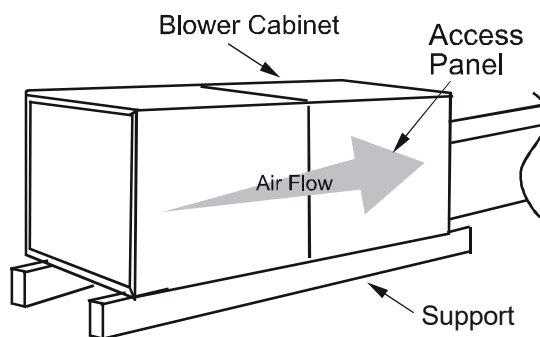

Figure 4 - Attic Installation

4. Attach return and supply ductwork. Seal connections.
5. Make electrical connections as specified in *Electrical Connections* section of this manual.

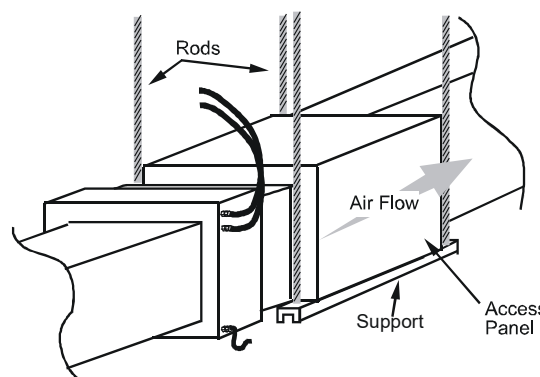

Figure 5 - Hanging Installation

COUNTERFLOW AND HORIZONTAL APPLICATIONS

Loosen motor mount and rotate motor (See Figure 6). Be sure motor is oriented with the female connections on the casing pointing down. If the motor is not oriented with the connections pointing down, water could collect in the motor and cause premature failure.

NOTE: After rotating motor, tighten motor mount to secure motor. Be sure that the gap between the motor and the insulation is the same as it was before loosening the motor mount. This will ensure that the blower wheel is properly spaced inside the blower housing.

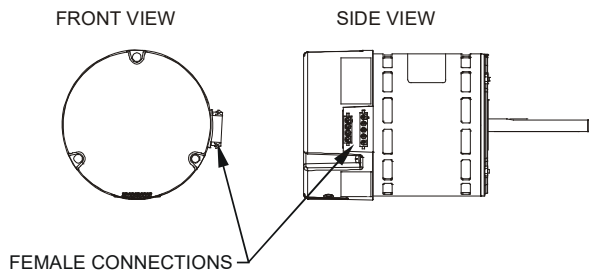

Figure 6 - MBVB Motor Orientation

ELECTRICAL CONNECTIONS

If this modular blower is matched up with a cased coil from the CAPEA, CAPE, CHPE, or CXTQ product families, the cased coil PCB must be supplied with 24VAC from an appropriately powered transformer. A transformer has been included with the cased coil. Refer to the cased coil installation & operation instruction manual regarding transformer parts and installation. A disconnect should be incorporated in the field wiring in accordance with wiring codes. Consult the local power company and local codes before installing this unit. All wiring must be in accordance with the National Electrical Code as well as all local codes. Knockouts have been provided on side and top of the cabinet for the installation of the electrical conduit. If the knockouts on the cabinet sides are used for electrical conduit, an adapter ring must be used in order to meet UL60335-2-40 safety requirements. Use Minimum Circuit Ampacity and type of wire to determine proper wire size. The unit MUST be properly grounded. A ground lug is provided in the unit.

Check all factory connections before connecting electrical power to unit to ensure none were loosened or disconnected during shipping and handling.

208/230 VOLT LINE CONNECTIONS

If heater kits will not be installed, remove the proper size knockout for the electrical conduit connection. Connect electrical conduit to the unit using two washers to make an approved connection. If the high voltage knockout is removed, please use the provided foam tape to seal the opening with the conduit.

The power supply wires must be connected to the red and black power wiring. Two wire nuts are provided in the bag assembly for this connection. Wrap the wire nuts with electrical tape. (Insulated crimp type connectors, field supplied, may be substituted for the wire nuts and electrical tape provided proper size connectors are used.) A ground wire MUST be connected to the ground lug inside the unit.

LOW VOLTAGE WIRING

A 24V-control voltage connects the air handler to the room thermostat and condenser and must use low voltage wiring with copper conductors. A minimum 18 AWG wire must be used for installations up to 150 feet. Low voltage wiring must be connected through the top of the cabinet or either side. If the low voltage opening is being used, please replace the pre-installed cap with the bushing provided in the literature kit.

WARNING

HIGH VOLTAGE!

TO PREVENT PERSONAL INJURY OR DEATH DUE TO ELECTRICAL SHOCK, DISCONNECT THE ELECTRICAL POWER BEFORE ELECTRICALLY CONNECTING THE UNIT.



WARNING

TO AVOID THE RISK OF FIRE OR EQUIPMENT DAMAGE, USE COPPER CONDUCTORS.

CAUTION

TO AVOID THE RISK OF PERSONAL INJURY, WIRING TO THE UNIT MUST BE PROPERLY POLARIZED AND GROUNDED.

WARNING

ALL WIRING MUST COMPLY WITH APPLICABLE LOCAL AND NATIONAL CODES. TYPE AND LOCATION OF FUSED DISCONNECT SWITCH(ES) MUST COMPLY WITH ALL APPLICABLE CODES AND PROVIDE OVERCURRENT PROTECTION AS SHOWN ON THE NAMEPLATE.

OPERATION ON 208 VOLT SUPPLY

The unit transformer is factory connected for 230 V operation. If unit is to operate on 208 V, disconnect the red wire from terminal 3 of the unit transformer and connect them to terminal 2 of the unit transformer.

24 VOLT THERMOSTAT WIRING

NOTE: Removable connectors are provided with the control to make thermostat wire connections. The connectors may be removed, wire connections made and the connector replaced. It is **STRONGLY** recommended that you do not connect multiple wires into a single terminal. Wire nuts are recommended to ensure one wire is used for each terminal. Typical 18 AWG thermostat wire may be used to wire the system components. 150 feet is the maximum recommended length of wire recommended between indoor and outdoor unit, or between indoor unit and thermostat.

NOTE: Wire routing must not interfere with the circulator blower operation or routine maintenance.

COOLCLOUD™ HVAC PHONE APPLICATION

NOTE: This equipment has been tested and found to comply with the limits for a Class B digital device, pursuant to part 15 of the FCC Rules. These limits are designed to provide reasonable protection against harmful interference in a residential installation. This equipment generates, uses and can radiate radio frequency energy and, if not installed and used in accordance with the instructions, may cause harmful interference to radio communications. However, there is no guarantee that interference will not occur in a particular installation. If this equipment does cause harmful interference to radio or television reception, which can be determined by turning the equipment off and on, the user is encouraged to try to correct the interference by one or more of the following measures:

- Reorient or relocate the receiving antenna.
- Increase the separation between the equipment and receiver.

- Connect the equipment into an outlet on a circuit different from that to which the receiver is connected.
- Consult the dealer or an experienced radio/ TV technician for help.

Actual screens may look different based on the mobile device being used.

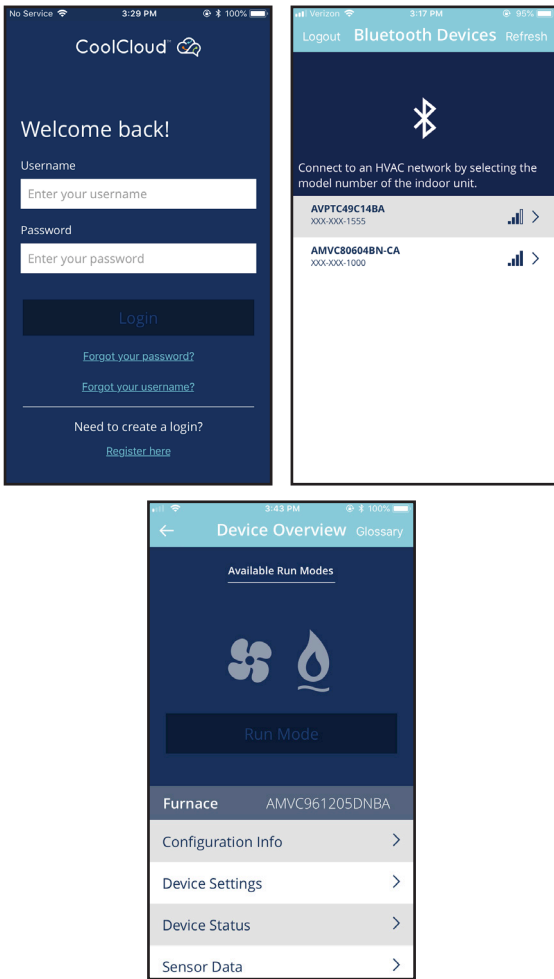

Figure 7

This air handler is Bluetooth® ready and functions with the Cool Cloud HVAC phone application designed to improve the contractor’s setup / diagnostic experience. Users can see specific model information, review active diagnostic error codes, observe system menu testing of all operational modes (heat / cool / fan) directly from the phone. The phone application is also capable of directly updating the air handler software anytime updates are available. The application will automatically notify the user.

NOTE: The software update may take up to 20 minutes to complete.

The Bluetooth® word mark and logos are registered trademarks owned by Bluetooth SIG, Inc., and any use of such marks are under license.

QUICK START GUIDE FOR COMMUNICATING OUTDOOR UNITS

EXTREMELY IMPORTANT: For all cooling calls the system only requires a single Y input from the thermostat. For all heating calls (including applications with backup electric heater kits) the system only requires a single W input from the thermostat. Internal algorithms will control all available cooling and heating stages based on these inputs. Any single-stage 24VAC thermostat can be used. For proper operation, the thermostat must be setup to control a single stage AC outdoor unit and to control single stage electric heat operation. The control board does not accommodate an O wire thermostat input (reversing valve signal). If a heat pump is installed, the thermostat should be setup as stated above. Setting the thermostat for the heat pump control or multistage control may result in incorrect performance.

1. Connect all necessary thermostat wires to the thermostat connector on the air handler control as instructed by the applicable wiring diagrams shown in this section.
2. Connect the 1 & 2 wires between the indoor and outdoor unit for communicating operation.

Note: Verify two stage outdoor units include a 24VAC transformer (for outdoor control board power). Two stage outdoor units may not behave properly without this 24 VAC transformer.

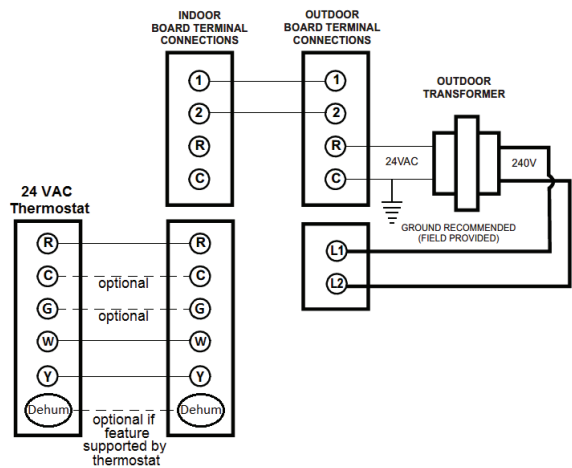

Communicating Two Stage Air Conditioner or Heat Pump

Figure 8

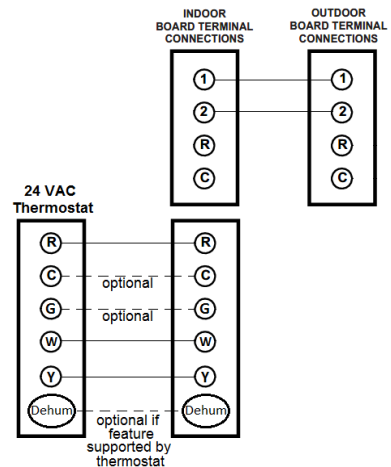

Communicating Inverter Air Conditioner or Heat Pump

Figure 9

- Download the **CoolCloud** HVAC phone application for charging and to configure /test system.

NOTE: When new versions of Bluetooth Communication Software and Air Handler Control Software are available, the phone application notifies the user. Software updates are classified as either optional or mandatory and installed by using the phone application. Ensure all mandatory software updates have been installed. Review notes for optional software updates and install if necessary.

NOTE: If an E11 code exists for the inverter system immediately after line voltage is applied (code displayed on the outdoor inverter control), the System Verification Test needs to be completed before any other operation. See the following procedure.

- Provide Line Voltage to the Inverter and MBVB systems
- Allow the system to remain idle for 5 minutes
- Apply a G call (FAN CALL) to the MBVB control. Do not provide any other 24VAC thermostat call. Confirm the blower starts running. This step is critical. The MBVB blower must be running before continuing to step 4.

NOTE: The following steps must be completed on the outdoor inverter control board. Not on the MBVB control.

- Locate the 3 push buttons under the 3 seven segment displays.

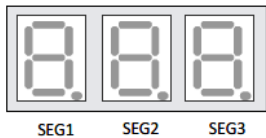

DISPLAY BUTTON LAYOUT

The display buttons shown can be used to navigate and select items:

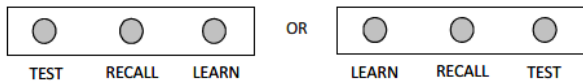

Examples of button layout are shown above. Identify correct display buttons on your unit PCB.

- The 7 Segment display should be showing E 1 1.
- Press and hold the RECALL button for 5 seconds. The 7 Segment display should show 1.00. Release the RECALL button.
- Press and hold the RECALL button again for another 5 seconds. The 7 Segment display should show 2.0 1. Release the RECALL button.
- Press and hold BOTH the RECALL AND TEST buttons for 5 seconds. The 7 Segment display should show 4.0 1. Release the RECALL AND TEST buttons. Note, if you only hold the RECALL button during this step the display will show 3.0 1. You will then need to press the LEARN button and then start over from step 5.
- Press and release the RECALL button (do not hold it down) 3 times until the 7 Segment display shows 4.04.
- Press and Release the TEST button. The 7 Segment display will show - .0 1.
- Press and release the RECALL button. The 7 Segment display will show - .00. Note: the display will be flashing at this time.
- Press and release the TEST button to stop the flashing.

- Press and release the TEST button again to exit this menu.
- Step 13 successfully enable the mandatory system test. Press the LEARN button to return to the main screen. The 7 Segment display will show E 1 1. The outdoor Inverter will start up momentarily. Once the system test has completed, any errors seen during the test will be displayed. If the test passed, E 1 1 will clear, the system will shut down by itself and you can proceed to charging.

CHARGING INSTRUCTIONS FOR AN INVERTER OUTDOOR UNIT

- Apply a G call (FAN CALL) to the MBVB control. Do not provide any other 24VAC thermostat call. Confirm the blower starts running. This step is critical. The MBVB blower must be running before continuing on.

NOTE: The following steps must be completed on the outdoor inverter control board. Not on the MBVB control.

- Locate the three push buttons under the three 7 Segment displays.



DISPLAY BUTTON LAYOUT

The display buttons shown can be used to navigate and select items:

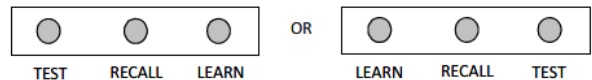

Examples of button layout are shown above. Identify correct display buttons on your unit PCB.

- The 7 Segment display should not be displaying anything at this point
- Press and hold the RECALL button for 5 seconds. The 7 Segment display should show 1.00. Release the RECALL button.
- Press and hold the RECALL button again for another 5 seconds. The 7 Segment display should show 2.0 1. Release the RECALL button.
- Press and hold BOTH the RECALL AND TEST buttons for 5 seconds. The 7 Segment display should show 4.0 1. Release the RECALL AND TEST buttons. Note, if you only hold the RECALL button during the step the display will show 3.0 1. You will then need to press the LEARN button and then start over from step 5.
- Press and release the RECALL button (do not hold it down) until the 7 Segment display shows 4.09.
- Press and release the TEST button. The 7 Segment display will show - .0 1.
- Press and release the RECALL button. The 7 Segment display will show - .00. Note: The display will be flashing at this time.
- Press and release the TEST button to stop the flashing
- Press and release the TEST button again to exit this menu
- Step 12 successfully enabled charge mode. Press the LEARN button to return to the main screen. The 7 Segment display will be blank again. The Outdoor Inverter will start up momentarily in charge mode and will remain in charge mode for 1 hour.

NOTE: the installer must manually shut off charge mode once complete. To do so, follow the same push button procedures as shown above (steps 2-7). After pressing the RECALL button at step 8, if the 7 Segment display shows -.01 it means the system has already terminated charge mode. Pressing the LEARN button will exit the menus. If after pressing the RECALL button at step 8, the 7 Segment displays still show -.00, press RECALL to change the display to -.01 then press the TEST button two times and finally the LEARN button to exit the menus. The system will shut down after a couple of minutes meaning charge mode is off.

CHARGING INSTRUCTIONS FOR A TWO-STAGE OUTDOOR UNIT

1. Two-stage outdoor units using the **CoolCloud** HVAC application:
 - a. Using the cooling icon after entering the outdoor unit menus, energize the outdoor unit to 49% capacity or lower.
 - b. Charge the outdoor unit as required using the charging information provided with the outdoor equipment.

QUICK START GUIDE FOR NON-COMMUNICATING OUTDOOR UNITS

When setting up a ComfortBridge air handler for use with a Non-Communicating outdoor unit you must set airflow in the “ton” menu on the PCB or in the **CoolCloud** HVAC APP. Failure to do so will result in the air handler PCB displaying “i dL” and the blower will not operate with a call for cooling. The Board does not need to be replaced, you **MUST** set the airflow first.

EXTREMELY IMPORTANT: For two stage electric heat kit control the system only needs a single W input. Internal algorithms will control staging automatically based on the single W input. For non-communicating outdoor unit wiring, see instructions below:

1. Use the wiring diagrams on the next page to connect low voltage thermostat wires.

NOTE: When installing the air handler with a non-communicating heat pump, wire directly to the “O” terminal on the non-communicating heat pump. See the following figures.

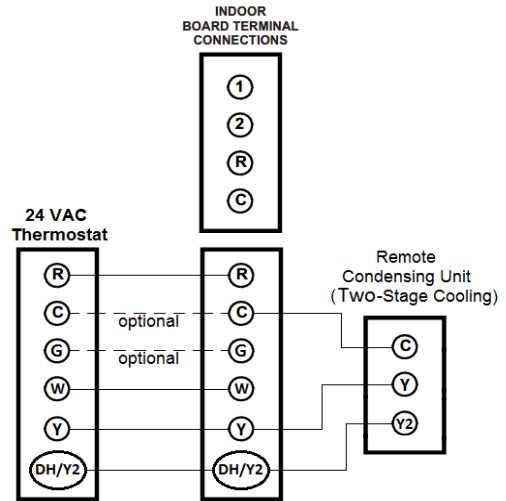

Non-Communicating Two Stage A/C
Figure 11

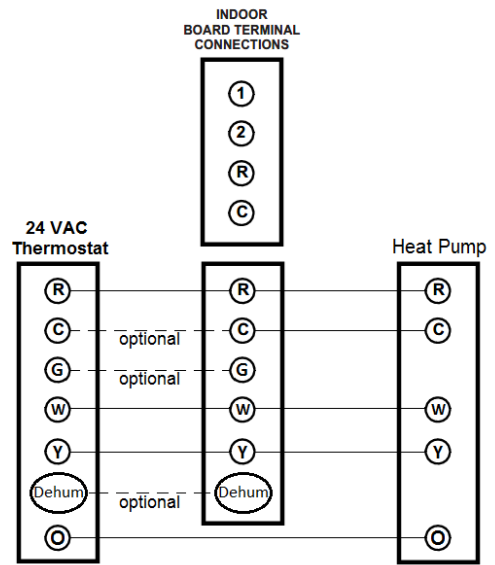

Non-Communicating Single Stage Heat Pump
Figure 12

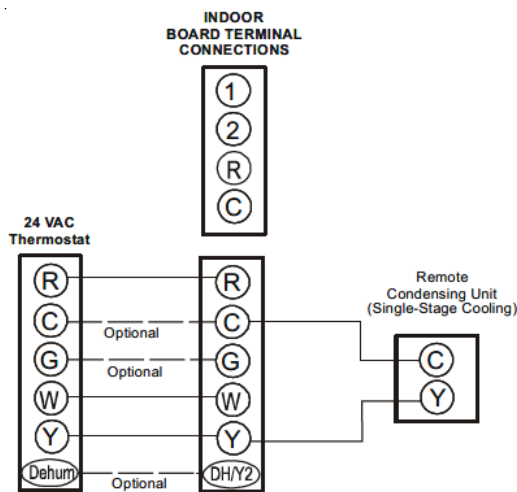

Non-Communicating Single Stage A/C
Figure 10

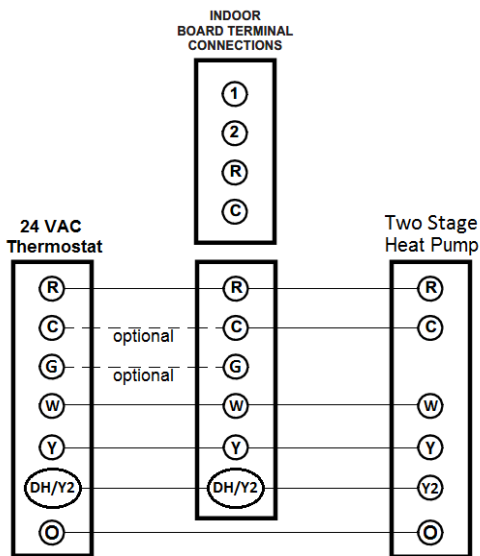

Non-Communicating Two Stage Heat Pump
Figure 13

Model	MAX CFM
MBVB12BP1400	1200
MBVB16CP1400	1600
MBVB20DP1400	2000

- Use the **CoolCloud** HVAC phone application to configure/ test **air handler** operations.

NOTE: The phone application cannot test a non-communicating **outdoor unit**. The thermostat will be required for outdoor unit testing.

CHARGING

- Two-stage outdoor units:
 - Provide a low stage cooling call from the thermostat and charge accordingly.
- Single-stage outdoor units:
 - Provide a cooling call from the thermostat and charge accordingly.

ELECTRIC HEAT KIT TESTING

- Select the electric heat icon after entering the air handler menus in the **CoolCloud** HVAC phone application.
- Select any value less than 50% for low stage operation and any value greater than 50% for high stage operation.

Confirm thermostat heating and cooling calls function properly with equipment.

DEHUMIDIFICATION

Dehumidification allows the air handler's circulator blower to operate at a reduced speed during a combined thermostat call for cooling and a dehumidification call from the thermostat or humidistat. This lower blower speed increases dehumidification of the conditioned air as it passes through the indoor coil. The control board is equipped with a 24 volt dehumidification input (DH) located on the thermostat wiring connector. The terminal can be configured to enable dehumidification when the input is energized or de-energized. When using an external dehumidistat, connect it between the R and DH terminals. If the humidistat closes on humidity rise or the thermostat energizes this terminal when dehumidification is required, set the control board Dehum Logic Menu (*dHL*) to "Hi" using the push buttons or **CoolCloud** HVAC phone application. If the humidistat opens on humidity or the thermostat de-energizes this terminal when dehumidification is required, set the Dehum Logic Menu to "Lo" using the push buttons or **CoolCloud** HVAC phone application.

- Download the **CoolCloud** HVAC phone application.

Note: When new versions of Bluetooth Communication Software and Air Handler Control Software are available, the phone application notifies the user. Software updates are classified as either optional or mandatory and installed by using the phone application. Ensure all mandatory software updates have been installed. Review notes for optional software updates and install if necessary.

- Go to the Non-Comm Outdoor Setting Menu (*OdS*) using the on board push buttons or the **CoolCloud** HVAC phone application. Select "IAC" for single stage Air Conditioners, "IHP" for single stage Heat Pumps, "2AC" for two stage Air Conditioners and "2HP" for 2 stage Heat Pumps.
- Go to the Tonnage Units Menu (*TON*) and select the tonnage value that corresponds to the desired airflow for the outdoor unit. See the following table.

NOTE: For the two stage non-communicating outdoor units, system will stage airflow automatically for low stage operation.

Tonnage Selection	Airflow	Tonnage Selection	Airflow	Tonnage Selection	Airflow	Tonnage Selection	Airflow
1	400	2.3	920	3.6	1440	4.9	1960
1.1	440	2.4	960	3.7	1480	5	2000
1.2	480	2.5	1000	3.8	1520	5.1	2040
1.3	520	2.6	1040	3.9	1560	5.2	2080
1.4	560	2.7	1080	4	1600	5.3	2120
1.5	600	2.8	1120	4.1	1640	5.4	2160
1.6	640	2.9	1160	4.2	1680	5.5	2200
1.7	680	3	1200	4.3	1720	5.6	2240
1.8	720	3.1	1240	4.4	1760	5.7	2280
1.9	760	3.2	1280	4.5	1800	5.8	2320
2	800	3.3	1320	4.6	1840	5.9	2360
2.1	840	3.4	1360	4.7	1880	6	2400
2.2	880	3.5	1440	4.8	1920		

NOTE: The system will not provide airflows above the max Airflow Value.

Dehumidification Control Options

Key Mitigations:

1. Full featured TS (dehum & overcool)
2. Connect G and dehum wire correctly
3. Dehumidistat

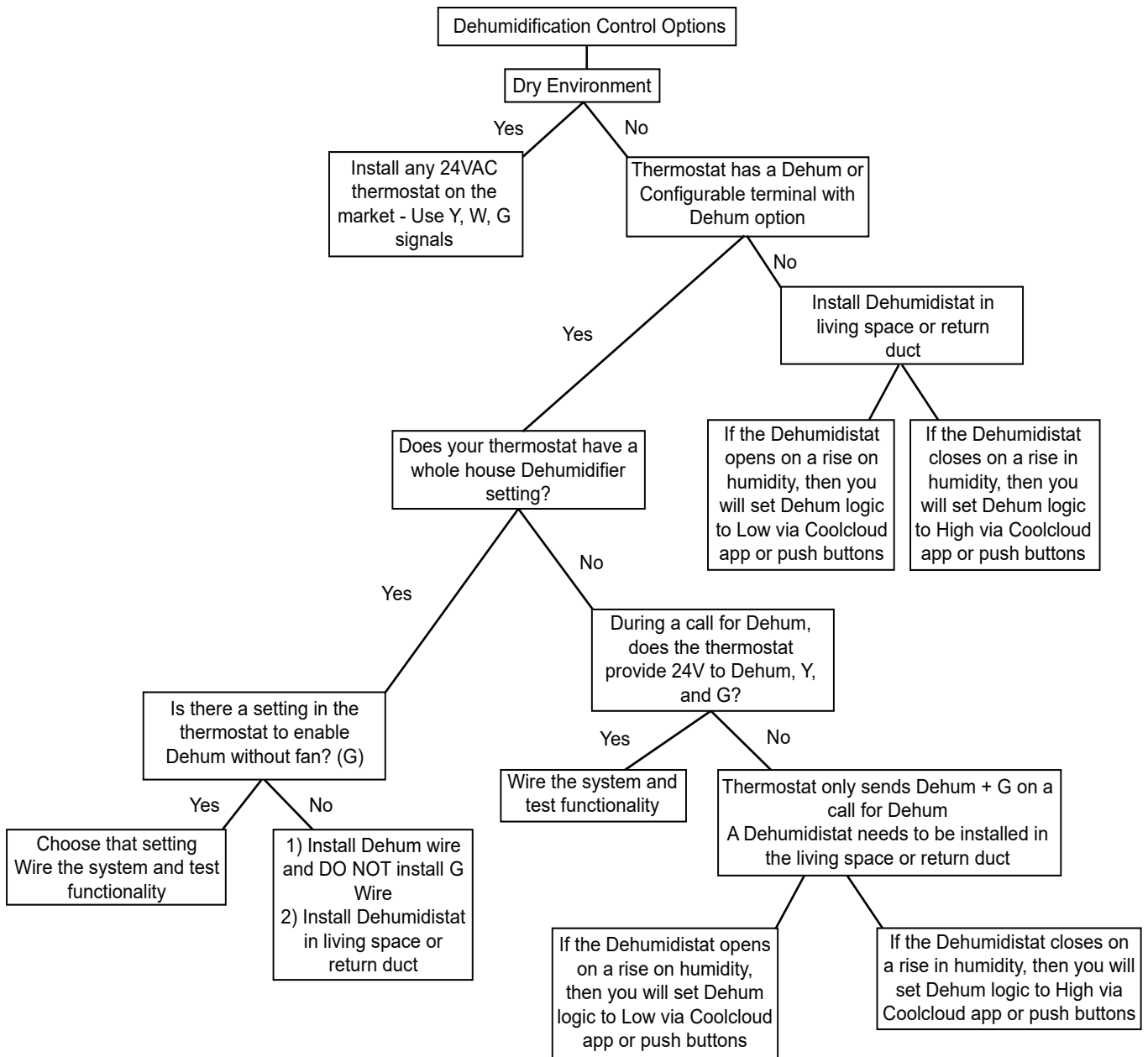

AUXILIARY ALARM SWITCH

The control is equipped with a 24VAC Aux Alarm to be used for a condensate switch install (designated by CONDENSATE IN/OUT on the control). By default, the connected AUX switch is normally closed and opens when the water level in the evaporator coil base pan reaches an undesirable level. The control responds by displaying a "E₁F" error code and turning off the outdoor condensing unit. If the AUX switch is detected to be in the closed position for 30 seconds, normal operation resumes and the error message is no longer displayed.

7-SEGMENT DISPLAY AND PUSH BUTTONS

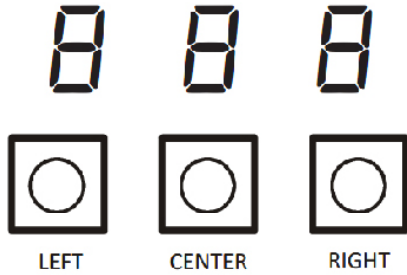

Figure 14

The air handler includes three on-board push buttons allowing users to navigate indoor and outdoor system menus. The Right and Left buttons allow the user to scroll through the main menu and to then scroll through available options within specific menus. The Center button is used to enter into a main menu and to then permanently select options within those menus.

NOTE: After scrolling to the desired option within a menu, that option may be flashing on the 7-segment displays. This indicates the option has not been officially selected. Pressing the Center button two times will select that option. The first press will stop the flashing. The second will make the selection official and return you to the main menu.

ACCESSORY CONTROL (HUMIDIFIERS, DEHUMIDIFIERS, VENTILATORS)

If an external humidifier, dehumidifier or ventilator is installed, it may require airflow from the HVAC system to function properly.

1. Make sure the installed Non-Communicating thermostat is capable of controlling the accessory or accessories.
2. Connect the appropriate accessory control wires to the accessory devices from the thermostat (see thermostat manual for connection and setup instructions).
3. If the thermostat is capable of providing a continuous fan call (G signal) during accessory operation: Make sure to connect the thermostat G terminal to the G terminal on the indoor unit. Setup thermostat to ensure G signal is energized during accessory operation.

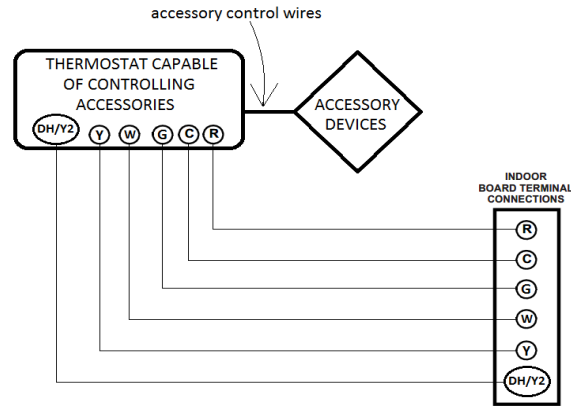

Figure 15

4. Select the appropriate fan only airflow for the accessory using the indoor unit push button menus or the **CoolCloud** HVAC phone application.
5. Using the thermostat, independently test each accessory in addition to independently testing continuous fan mode.

RAMPING PROFILES

The variable-speed circulator offers four different ramping profiles. These profiles may be used to enhance cooling performance and increase comfort level. Select the desired ramping profile using the **CoolCloud** phone application or the push button menus.

When used with communicating outdoor units the cooling profile must be selected in the outdoor unit menus.

When used with non-communicating outdoor units the cooling profiles must be selected in the indoor unit menus.

- Profile A provides only an OFF delay of one (1) minute at 100% of the cooling demand airflow.

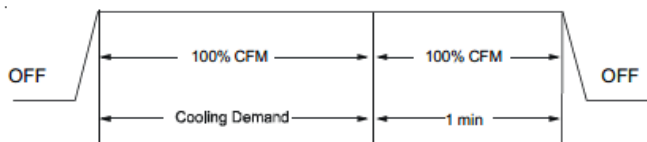

- Profile B ramps up to full cooling demand airflow by first stepping up to 50% of the full demand for 30 seconds. The motor then ramps to 100% of the required airflow. A one (1) minute OFF delay at 100% of the cooling airflow.

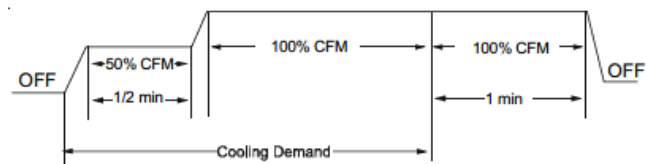

- Profile C ramps up to 82% of the full cooling demand airflow and operates there for approximately 7 1/2 minutes. The motor then steps up to the full demand airflow. Profile C also has a one (1) minute 100% OFF delay.

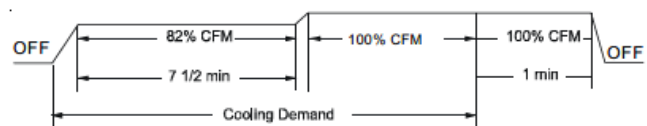

- Profile D ramps up to 50% of the demand for 1/2 minute, then ramps to 82% of the full cooling demand airflow and operates there for approximately 7 1/2 minutes. The motor then steps up to the full demand airflow. Profile D has a 1/2 minute at 50% airflow OFF delay.

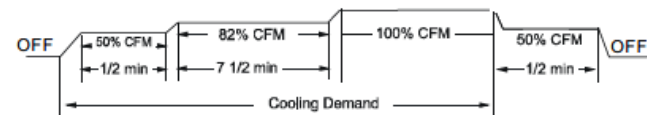

Figure 16

ELECTRIC AIR CLEANER

The control is equipped with an Accessory Relay and a pair of ¼ inch accessory terminals which is normally open, labeled EAC-IN and EAC-OUT (see accessory contacts graphic). The Accessory Relay is configured to close anytime the blower is running. A closed relay means the two terminals will have continuity between them (the control does not energize these contacts). It is recommended to utilize 24VAC with these terminals and limit the current to 1A.

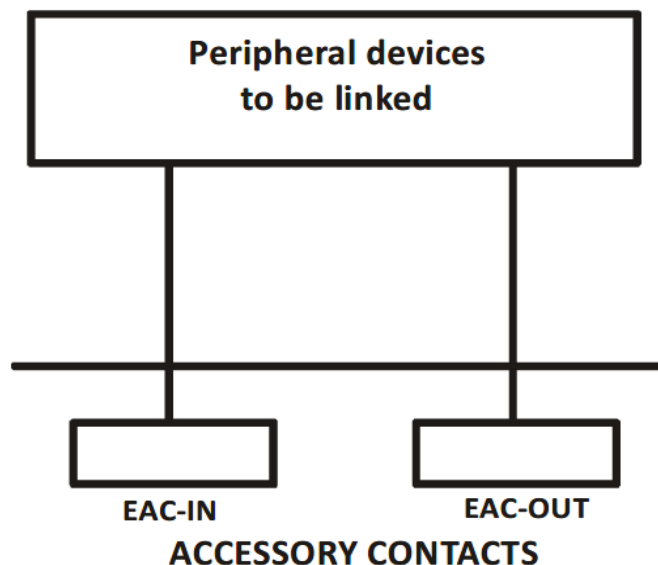

Figure 17

TROUBLESHOOTING

ELECTROSTATIC DISCHARGE (ESD) PRECAUTIONS

NOTE: Discharge body's static electricity before touching unit. An electrostatic discharge can adversely affect electrical components.

Use the following precautions during modular blower installation and servicing to protect the integrated control module from damage. By putting the modular blower, the control, and the person at the same electrostatic potential, these steps will help avoid exposing the integrated control module to electrostatic discharge. This procedure is applicable to both installed and uninstalled (ungrounded) blowers.

1. Disconnect all power to the blower. Do not touch the integrated control module or any wire connected to the control prior to discharging your body's electrostatic charge to ground.
2. Firmly touch a clean, unpainted, metal surface of the modular blower near the control. Any tools held in a person's hand during grounding will be discharged.
3. Service integrated control module or connecting wiring following the discharge process in step 2. Use caution not to recharge your body with static electricity; (i.e., do not move or shuffle your feet, do not touch ungrounded objects, etc.). If you come in contact with an ungrounded object, repeat step 2 before touching control or wires.
4. Discharge your body to ground before removing a new control from its container. Follow steps 1 through 3 if installing the control on a blower. Return any old or new controls to their containers before touching any ungrounded object.

TROUBLESHOOTING MATRIX

Symptoms of Abnormal Operation	Diagnostic / Status LED Codes	Fault Description	Possible Causes	Corrective Actions
No outdoor unit operations	EC1	Communication error with outdoor unit	Improper low voltage wiring between the indoor and outdoor unit Outdoor control board lost power during operation	Locate and correct improper low voltage wiring issue Identify reason outdoor control board lost power during operation
No Air Handler operation	E05	Open fuse	Short in low voltage wiring	Locate and correct short in low voltage wiring Replace fuse with 3-amp automotive type
No Air Handler operation	E0F	Auxiliary switch (condensate switch) open or open fuse	High water level in the evaporation coil or short in low voltage wiring	Check evaporator drain pan, trap, piping Replace fuse with 3-amp automotive type
No Air Handler operation	Ed0	Data not yet on network	No network data	Populate shared data set using Cool Cloud App
No Air Handler operation	Ed1	Invalid shared data	Air Handler blower does not contain an appropriate shared data set	Populate correct shared data using Cool Cloud App
Operation different than expected or no operation	Ed4	Invalid shared data	Shared data set on Cool Cloud App card has been rejected by integrated control module	Verify shared data set is correct for the specific model. Re-populate data using correct shared data if required
No Air Handler operation	Eb0	Circulator blower motor not running with demand present	Loose or disconnected wiring connection at circulator motor power leads Loose or disconnected wiring connection at PCB Board Connector Failed circulator blower motor	Tighten or correct wiring connection at motor power leads. Tighten or correct wiring connection at PCB Board Check circulator blower motor and Replace if necessary
No Air Handler operation	Eb1	Integrated control module has lost communications with circulator blower motor	Loose wiring connection at circulator motor control leads Failed circulator blower motor Failed integrated control module	Tighten or correct wiring connection Check circulator blower motor, replace if necessary Check integrated control module, replace if necessary
No Air Handler operation	Eb2	Circulator blower motor horse power in shared data set does not match circulator blower motor horse power	Incorrect circulator blower motor in Air Handler Incorrect shared data set in integrated control module	Verify circulator blower if motor horse power is the same specified for the specific Air Handler model, replace if necessary Verify shared data set is correct for the specific model, re-populate data using correct shared data if required
Air Handler operates at reduced performance Airflow delivered is less than expected	Eb3	Circulator blower motor is operating in a power, temperature, or speed limiting condition	Blocked filters Restrictive or undersized ductwork High ambient temperatures	Check filters for blockage, clean filters or remove obstruction Check ductwork for blockage, remove obstruction and verify all registers are fully open Verify ductwork is appropriately sized for system and resize/replace as needed

TROUBLESHOOTING MATRIX (CONTINUED)

Symptoms of Abnormal Operation	Diagnostic / Status LED Codes	Fault Description	Possible Causes	Corrective Actions
No Air Handler operation	Eb4	Circulator blower motor senses a loss of rotor control Circulator blower motor senses high current	Abnormal motor loading, sudden change in speed or torque, sudden blockage of air handler air inlet or outlet	Check filters, filter grills/registers, duct system and air handler inlet/outlet for blockages
No Air Handler operation	Eb5	Circulator blower motor fails to start 10 consecutive times	Obstruction in circulator blower housing Seized Circulator blower motor bearings Failed circulator blower motor	Check circulator blower for obstructions Remove and repair/replace wheel/motor if necessary Check circulator blower motor shaft rotation and motor, replace motor if necessary
No Air Handler operation	Eb6	Circulator blower motor shuts down for over or under voltage condition Circulator blower motor shuts down due to over temperature condition on power module	High or low AC line voltage to air handler High ambient temperatures	Check power to air handler Verify line voltage is within the range specified on the rating plate
No Air Handler operation	Eb7	Circulator blower motor does not have enough information to operate properly Motor fails to start 40 consecutive times	Error with integrated control module shared data	Verify control is populated with the correct shared data
Air Handler operates at reduced performance or operates on low stage when high stage is expected	Eb9	Airflow is lower than demanded	Blocked filters or restrictive ductwork Undersized ductwork	Check filters for blockage, clean filters or remove obstruction Check ductwork for blockage, remove obstruction and verify all registers are fully open Verify ductwork is appropriately sized for system, resize/replace ductwork if necessary

PUSH BUTTON MENUS

Note: When installed with an inverter outdoor unit, any change made to the inverter default settings must be made using the push button on the outdoor unit control board. See inverter unit installation manual for push button menu instructions.

LED Display	Menu Description
L6F	View 6 most recent fault codes and Clear Fault Codes if desired (furnace)
Lrn	Restart communications between the indoor and outdoor unit.
Cr	Control Firmware Revision Number
Sr	Control Shared Data Revision Number
F5d	Constant Fan Speed as percent of maximum airflow. Default = 30%
EHE	Electric Heater Kit Wattage (kW)
EFD	Electric Heat Off Delay (seconds)
End	Electric Heat On Delay (seconds)
ETF	Electric Heat Airflow Trim (percentage)
Est	Percentage of high stage electric heating airflow to run during low stage electric heat operation
CF5	1 = system will try to satisfy the thermostat quickly. 5 (default) = system will try to satisfy the thermostat more slowly.
dHL	Select "Hi" to enable dehumidification when the thermostat DH terminal is energized. Select "Lo" to enable dehumidification when the thermostat DH terminal is de-energized. (default = Hi)
QdS	Select number of stages for the non-communicating outdoor unit. (IRC for single-stage Air Conditioners, IHP for single stage Heat Pumps, 2RC for two stage Air Conditioners or 2HP for two stage heat pumps)
ton	Indoor Airflow for non-communicating outdoor units. (values based on 400CFM per ton) (default = 3.0 Ton)
ETF	Cooling Airflow Trim (default 0%)
CRP	Cooling Airflow Profile setting (default = profile D shown as 4)
Cnd	Cooling Airflow On Delay Time (default = 5 seconds)
CFd	Cooling Airflow Off Delay Time. (default = 60 seconds)
CSt	Percentage of high stage cooling airflow to run during low stage operation. (default = 70%)
dHS	Electric heat operation during defrost. 1 = low stage 2 (default) = high stage
HtF	Heat Pump Indoor Airflow Trim (default = 0%)
HFD	Heat Pump Heating Airflow Off Delay Time (default = 60 seconds)
Hnd	Heat Pump Heating Airflow On Delay Time (default = 5 seconds)
HSt	Percentage of high stage heat pump heating airflow to run during low stage operation. (default = 70%)
EHR	When heat pump heating and electric heat are running at the same time, this percentage is used for additional airflow trim
dHE	Enables or disables dehumidification feature in the outdoor unit. (default = Enabled)
CbP	Balance point temperature. The Compressor will not operate below temperature. (Default = 0°F)
EbP	Backup Heat Balance Points
Hdi	Compressor run time between defrost cycles. (default = 30 minutes) (2 stage units)
CdL	Compressor off delay at the beginning and end of a defrost cycle. (default = 30 seconds)

PUSH BUTTON MENUS (CONTINUED)

LED Display	Menu Description
FCL	View 6 most recent fault codes and Clear Fault Codes if desired (outdoor communicating units)
t9t	Menu is enabled if the CF5 menu is set to 6. Select the target time the system will attempt to satisfy the thermostat.
SUP	Menu is enabled if the CF5 menu is set to 6. Select the percentage past the target time when the system will enable electric heat operation during heat mode.
0tt	Menu is enabled if the CF5 is set to 6. (Electric heat will run during the next heat call if the heat pump fails to satisfy the custom target time for this number of consecutive cycles) (default = 20 cycles)
utt	Menu is enabled if the CF5 menu is set to 6. (if the addition of low stage electric heat is able to consecutively satisfy the thermostat under the set target time for this number of cycles, the system will transition to the heat pump for primary heating)
SDP	Menu is enabled if the CF5 menu is set to 6. (this percentage will help determine when switching back to heat pump only operation is appropriate. Default = 20%. If target time = 20 minutes, the addition of low stage electric heat must satisfy the thermostat by less than 16 minutes. (target time - 20% default = 16 minutes).

SYSTEM STATUS DISPLAY

LED Display	Description of System Status
<i>IDL</i>	Idle
<i>FAN</i>	Constant Fan
<i>AC</i>	Compressor Cooling, Single-Stage (non-comm units)
<i>1AC</i>	Compressor Cooling, Low Stage (non-comm units)
<i>2AC</i>	Compressor Cooling, High Stage (non-comm units)
<i>AC 1</i>	Compressor Cooling, Low Stage (comm units)
<i>AC 2</i>	Compressor Cooling, High Stage (comm units)
<i>HP</i>	Compressor Heat, Single-Stage (non-comm. units)
<i>1AC</i>	Compressor Heat, Low Stage (non-comm units)
<i>2AC</i>	Compressor Heat, High Stage (non-comm units)
<i>HP 1</i>	Compressor Heat, Low Stage (Comm Units)
<i>HP 2</i>	Compressor Heat, High Stage (Comm Units)
<i>HE</i>	Electric Heat, Single Stage
<i>HE 1</i>	Electric Heat, Low Stage
<i>HE 2</i>	Electric Heat, High Stage
<i>*dFt</i>	Defrost, Single Stage Electric Heat (non-comm units)
<i>dF 1</i>	Defrost, Low Stage Electric Heat
<i>dF 2</i>	Defrost, High Stage Electric Heat
<i>dHU</i>	Dehumidification

* If a system is a heat pump connected legacy, then a DFT will show on the board in 2 instances.

1. If the heat pump calls for a defrost, Y and a W will be energized resulting in a DFT code on the air-handler display.
2. If the heat pump calls for auxiliary heat, Y and a W will be energized resulting in a DFT code on the air-handler display.

AIRFLOW LABEL

Menu Navigation and Selection Instructions

Using Phone Application over Bluetooth Network:

- 1) Connect to the air handler (instructions provided by phone during connection process).
- 2) Select desired settings menu
- 3) Select item that requires adjustment and make necessary selection
- 4) Submit Changes

Using On-Board Push Buttons:

- 1) Use the Right and Left Buttons to scroll between menus
- 2) Use the Center Button to select desired menu when menu code is shown on 7-segment displays
- 3) Use the Left and Right Buttons to scroll through options within the desired menu (the display will flash while scrolling through options for selection)
- 4) Use the Center Button to select the displayed option (when selected the display will stop flashing)
- 5) Use the Center Button to finalize selection and return to the main menu

Profiles	Pre-Run	Short-Run	OFF Delay
1	-----	-----	60 sec/100%
2	-----	30 sec/50%	60 sec/100%
3	-----	7.5 min/82%	60 sec/100%
4	30 sec/50%	7.5 min/82%	60 sec/100%

Airflow Settings Instructions

- 1) For non-communicating installations, select the type of unit installed in the OdS menu (1AC = single-stage air conditioner, 1HP = single-stage heat pump, 2AC = 2 stage air conditioner, 2HP = 2 stage heat pump) Default = OFF (no outdoor unit).
- 2) Use the Tonnage Menu (ton) to select Cooling/Heat Pump Airflow (non-communicating installation). Tonnage selection options and corresponding airflow CFM can be found to the right.
[Airflow = Tonnage Selection x 400] Default selection is 6.0 tons.
- 3) [Optional] Use the Cooling Trim Menu (CtF) to adjust the cooling airflow from -10% to +10% (2% increments). This applies for 2 stage communicating outdoor units and single or 2 stage non-communicating outdoor units. For inverter outdoor units use Cooling Trim Factor High, Intermediate and Low menus (CtH, CtI, and CtL) for trim adjustment.
- 4) [Optional] Use the Heating Trim Menu (HtF) to adjust the heat pump airflow from -10% to +10% (2% increments). This applies for 2 stage communicating outdoor units and single or 2 stage non-communicating outdoor units. For inverter outdoor units use Heating Trim Factor High, Intermediate and Low menus (HtH, HtI, and HtL) for trim adjustment.
- 5) [Optional] Use the Constant Fan Menu (FSD) to select the percentage of maximum airflow for continuous fan
- 6) [Optional] Use the Cooling Airflow Profile Menu (CAP) to select between 4 cooling airflow profiles. Profile options 1-4 are listed above. See installation manual for further details

Tonnage Menu (t o n)

Tonnage Selection	Airflow	Tonnage Selection	Airflow
1.0	400	3.5	1400
1.1	440	3.6	1440
1.2	480	3.7	1480
1.3	520	3.8	1520
1.4	560	3.9	1560
1.5	600	4.0	1600
1.6	640	4.1	1640
1.7	680	4.2	1680
1.8	720	4.3	1720
1.9	760	4.4	1760
2.0	800	4.5	1800
2.1	840	4.6	1840
2.2	880	4.7	1880
2.3	920	4.8	1920
2.4	960	4.9	1960
2.5	1000	5.0	2000
2.6	1040	5.1	2040
2.7	1080	5.2	2080
2.8	1120	5.3	2120
2.9	1160	5.4	2160
3.0	1200	5.5	2200
3.1	1240	5.6	2240
3.2	1280	5.7	2280
3.3	1320	5.8	2320
3.4	1360	5.9	2360
3.5	1400	6.0	2400

Maximum Airflow Output

MBVB12BP1X00	MBVB16CP1X00	MBVB20DP1X00
1400	2000	2000

*If airflow is set above the model's maximum value, the output will be the maximum value

Electric Heat Airflow Table

Htr Kw	MBVB12BP1X00	MBVB16CP1X00	MBVB20DP1X00
3	600	800	800
5	600	800	800
6	635	800	800
8	740	1000	1000
10	1000	1000	1200
15	1400	1500	1500
19	NR	NR	NR
20	NR	NR	NR
21	NR	NR	NR
25	NR	NR	NR

Selecting Heater Kit: Use the Electric Heating Wattage Menu (EHT) to select heater kit size. See "Menu Navigation and Selection Instructions" above. Default selection is 0 (No Heat Kit). Select installed heater kit for heater kit operation.

NR - Not Rated



0140A01297-A

AIR HANDLER

AIR HANDLER HOMEOWNER'S ROUTINE MAINTENANCE RECOMMENDATIONS

We strongly recommend a bi-annual maintenance checkup be performed before the heating and cooling seasons begin by a qualified servicer.

REPLACE OR CLEAN FILTER

IMPORTANT NOTE: Never operate unit without a filter installed as dust and lint will build up on internal parts resulting in loss of efficiency, equipment damage and possible fire.

An indoor air filter must be used with your comfort system. A properly maintained filter will keep the indoor coil of your comfort system clean. A dirty coil could cause poor operation and/or severe equipment damage.

Your air filter or filters could be located in your furnace, in a blower unit, or in "filter grilles" in your ceiling or walls. The installer of your air conditioner or heat pump can tell you where your filter(s) are, and how to clean or replace them.

Check your filter(s) at least once a month. When they are dirty, replace or clean as required. Disposable type filters should be replaced. Reusable type filters may be cleaned.

You may want to ask your dealer about high efficiency filters. High efficiency filters are available in both electronic and non-electronic types. These filters can do a better job of catching small airborne particles.

**WARNING**



HIGH VOLTAGE!
DISCONNECT ALL POWER BEFORE SERVICING OR
INSTALLING THIS UNIT. MULTIPLE POWER SOURCES MAY BE
PRESENT. FAILURE TO DO SO MAY CAUSE PROPERTY DAMAGE,
PERSONAL INJURY OR DEATH.

MOTORS

Indoor and outdoor fan motors are permanently lubricated and do not require additional oiling.

ALUMINUM INDOOR COIL CLEANING

(QUALIFIED SERVICER ONLY)

This unit is equipped with an aluminum tube evaporator coil. The safest way to clean the evaporator coil is to simply flush the coil with water. This cleaning practice remains as the recommended cleaning method for both copper tube and aluminum tube residential evaporator coils.

It has been determined that many coil cleaners and drain pan tablets contain corrosive chemicals that can be harmful to aluminum tube and fin evaporator coils. Even a one-time application of these corrosive chemicals can cause premature aluminum evaporator coil failure. Any cleaners that contain corrosive chemicals including, but not limited to, chlorine and hydroxides, should not be used.

An alternate cleaning method is to use one of the products listed in TP-109* to clean the coils. The cleaners listed are the only agents deemed safe and approved for use to clean round tube aluminum coils. TP-109 is also available on the web site in Partner Link > Service Toolkit.

NOTE: Ensure coils are rinsed well after use of any chemical cleaners.

**CAUTION**

TO AVOID THE RISK OF EQUIPMENT DAMAGE OR FIRE, INSTALL THE SAME AMPERAGE BREAKER OR FUSE AS YOU ARE REPLACING. IF THE CIRCUIT BREAKER OR FUSE SHOULD OPEN AGAIN WITHIN THIRTY DAYS, CONTACT A QUALIFIED SERVICER TO CORRECT THE PROBLEM.
IF YOU REPEATEDLY RESET THE BREAKER OR REPLACE THE FUSE WITHOUT HAVING THE PROBLEM CORRECTED, YOU RUN THE RISK OF SEVERE EQUIPMENT DAMAGE.

BEFORE YOU CALL YOUR SERVICER

- Check the thermostat to confirm that it is properly set.
- Wait 15 minutes. Some devices in the outdoor unit or in programmable thermostats will prevent compressor operation for awhile, and then reset automatically. Also, some power companies will install devices which shut off air conditioners for several minutes on hot days. If you wait several minutes, the unit may begin operation on its own.
- Check the electrical panel for tripped circuit breakers or open fuses. Reset the circuit breakers or replace fuses as necessary.
- Check the disconnect switch near the indoor furnace or blower to confirm that it is closed.
- Check for obstructions on the outdoor unit. Confirm that it has not been covered on the sides or the top. Remove any obstruction that can be safely removed. If the unit is covered with dirt or debris, call a qualified servicer to clean it.
- Check for blockage of the indoor air inlets and outlets. Confirm that they are open and have not been blocked by objects (rugs, curtains or furniture).
- Check the filter. If it is dirty, clean or replace it.
- Listen for any unusual noise(s), other than normal operating noise, that might be coming from the outdoor unit. If you hear unusual noise(s) coming from the unit, call a qualified servicer.

Air Handler / Coil

Model Number _____

Serial Number _____

ELECTRICAL

Line Voltage (Measure L1 and L2 Voltage)

L1 - L2 _____

Secondary Voltage (Measure Transformer Output Voltage)

R - C _____

Blower Amps _____

Heat Strip 1 - Amps _____

Heat Strip 2 - Amps _____

BLOWER EXTERNAL STATIC PRESSURE

Return Air Static Pressure _____ IN. W.C.

Supply Air Static Pressure _____ IN. W.C.

Total External Static Pressure (Ignoring +/- from the reading above, add total here) _____ IN. W.C.

TEMPERATURES

Return Air Temperature (Dry bulb / Wet bulb) _____ DB °F _____ WB °F

Cooling Supply Air Temperature (Dry bulb / Wet bulb) _____ DB °F _____ WB °F

Heating Supply Air Temperature _____ DB °F

Temperature Rise _____ DB °F

Delta T (Difference between Supply and Return Temperatures) _____ DB °F

Air Handler / Coil - (Inverter Matched)

INVERTER AH / COIL ONLY

Check EEV and EEV wiring is secure (no adjustment required) _____

Additional Checks

Check wire routings for any rubbing _____

Check product for proper draining _____

Check screw tightness on blower wheel _____

Check factory wiring and wire connections _____

Check product for proper clearances as noted by installation instructions _____

°F to °C formula: (°F - 32) divided by 1.8 = °C °C to °F formula: (°C multiplied by 1.8) + 32 = °F

THIS PAGE INTENTIONALLY LEFT BLANK

CUSTOMER FEEDBACK

We are very interested in all product comments.

Please fill out the feedback form on one of the following links:

Goodman® Brand Products: (<http://www.goodmanmfg.com/about/contact-us>).

Amana® Brand Products: (<http://www.amana-hac.com/about-us/contact-us>).

You can also scan the QR code on the right for the product brand you purchased to be directed to the feedback page.



GOODMAN® BRAND



AMANA® BRAND

NOTE: SPECIFICATIONS AND PERFORMANCE DATE LISTED HEREIN ARE SUBJECT TO CHANGE WITHOUT NOTICE.

Visit our website at www.goodmanmfg.com or www.amana-hac.com for information on:

- Products
- Warranties
- Customer Services
- Parts
- Contractor Programs and Training
- Financing Options

Daikin Comfort Technologies Manufacturing, Inc.

19001 Kermier Rd., Waller, TX 77484

©2026

Amana is a registered trademark of Maytag or its related companies and is used under license. All rights reserved.