

INSTALLATION MANUAL

AIR CONDITIONER

Floor type

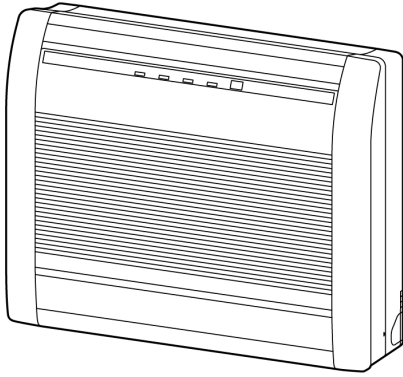

For authorized service personnel only.

- Branch box which is specified in this manual is the equipment to support the indoor unit of multi-connection type.
- All products are manufactured to metric units and tolerances. United States customary units are provided for reference only. In cases where exact dimensions and tolerances are required, always refer to metric units.

Contents

1. SAFETY PRECAUTIONS.....	1
1.1. IMPORTANT! Please read before starting.....	1
1.2. Special precautions.....	1
2. PRODUCT SPECIFICATION.....	2
2.1. Precautions for using R32 refrigerant.....	2
2.2. Refrigerant leakage sensor.....	4
2.3. Installation tools.....	4
2.4. For authorized service personnel only.....	5
2.5. Accessories.....	5
2.6. Pipe requirement.....	5
2.7. Electrical requirement.....	5
2.8. Optional parts.....	5
3. INSTALLATION WORK.....	5
3.1. Selecting an installation location.....	5
3.2. Side panel L, R removal and installation.....	6
3.3. Pipe installation.....	6
3.4. Electrical wiring.....	9
4. OPTIONAL INSTALLATION WORK.....	10
4.1. Before install optional wired remote controller.....	10
4.2. External input/output wire modification.....	10
4.3. Side panel L and control cover removal.....	10
4.4. Connecting cable to control board connector.....	11
4.5. Side panel L and control cover installation.....	12
4.6. Group control.....	12
5. FUNCTION SETTING.....	12
5.1. Function details.....	12
5.2. Temperature correction.....	14
6. TEST RUN.....	15
7. FINISHING.....	15
8. CUSTOMER GUIDANCE.....	15
9. ERROR CODES.....	15
10. REFRIGERANT LEAK DETECTION FUNCTION.....	16

The original language of this document is English.



PART No. 9378533127-01

1. SAFETY PRECAUTIONS

1.1. IMPORTANT! Please read before starting

This air conditioning system meets strict safety and operating standards. As the installer or service person, it is an important part of your job to install or service the system so it operates safely and efficiently.

For safe installation and trouble-free operation, you must:

- Carefully read this instruction booklet before beginning.
- Follow each installation or repair step exactly as shown.
- Observe all local, state, and national electrical codes.
- Pay close attention to all warning and caution notices given in this manual.



WARNING

This symbol refers to a hazard or unsafe practice which can result in severe personal injury or death.

CAUTION

This symbol refers to a hazard or unsafe practice which can result in personal injury and the potential for product or property damage.

• Hazard alerting symbols

Electrical	Safety/alert
	

If Necessary, Get Help

These instructions are all you need for most installation sites and maintenance conditions. If you require help for a special problem, contact our sales/service outlet or your certified dealer for additional instructions.

In Case of Improper Installation

The manufacturer shall in no way be responsible for improper installation or maintenance service, including failure to follow the instructions in this document.

1.2. Special precautions

● **When Wiring**

ELECTRICAL SHOCK CAN CAUSE SEVERE PERSONAL INJURY OR DEATH. ONLY A QUALIFIED, EXPERIENCED ELECTRICIAN SHOULD ATTEMPT TO WIRE THIS SYSTEM.

- Do not supply power to the unit until all wiring and tubing are completed or reconnected and checked.
- Highly dangerous electrical voltages are used in this system. Carefully refer to the wiring diagram and these instructions when wiring. Improper connections and inadequate grounding (earthing) can cause accidental injury or death.
- Ground (earth) the unit following local electrical codes.
- Connect all wiring tightly. Loose wiring may cause overheating at connection points and a possible fire hazard.

● **When Transporting**

Be careful when picking up and moving the indoor and outdoor units. Get a partner to help, and bend your knees when lifting to reduce strain on your back. Sharp edges or thin aluminum fins on the air conditioner can cut your fingers.

● **When Installing...**

...In a Ceiling or Wall

Make sure the ceiling/wall is strong enough to hold the unit's weight. It may be necessary to construct a strong wood or metal frame to provide added support.

...In a Room

Properly insulate any tubing run inside a room to prevent "sweating" that can cause dripping and water damage to walls and floors.

...In an Area with High Winds

Securely anchor the outdoor unit down with bolts and a metal frame. Provide a suitable air baffle.

...In a Snowy Area (for Heat Pump-type Systems)

Install the outdoor unit on a raised platform that is higher than drifting snow.

● **When Connecting Refrigerant Tubing**

- Keep all tubing runs as short as possible.
- Use the flare method for connecting tubing.
- Apply refrigerant lubricant to the matching surfaces of the flare and union tubes before connecting them, then tighten the nut with a torque wrench for a leak-free connection.
- Check carefully for leaks before opening the refrigerant valves.

● **When Servicing**

- Turn the power OFF at the main circuit breaker panel before opening the unit to check or repair electrical parts and wiring.
- Keep your fingers and clothing away from any moving parts.
- Clean up the site after you finish, remembering to check that no metal scraps or bits of wiring have been left inside the unit being serviced.
- After installation, explain correct operation to the customer, using the operation manual.

WARNING

- Never touch electrical components immediately after the power supply has been turned off. Electric shock may occur. After turning off the power, always wait 10 minutes before touching electrical components.
- Installation of this product must be done by experienced service technicians or professional installers only in accordance with this manual. Installation by non-professional or improper installation of the product might cause serious accidents such as

⚠ WARNING

injury, water leakage, electric shock, or fire. If the product is installed in disregard of the instructions in this manual, it will void the manufacturer's warranty.

- Do not turn on the power until all work has been completed. Turning on the power before the work is completed can cause serious accidents such as electric shock or fire.
- If refrigerant leaks while work is being carried out, ventilate the area. If the refrigerant comes in contact with a flame, it produces a toxic gas.
- Installation must be performed in accordance with regulations, codes, or standards for electrical wiring and equipment in each country, region, or the installation place.
- Do not use means to accelerate the defrosting process or to clean, other than those recommended by the manufacturer.
- This appliance is not intended for use by persons (including children) with reduced physical, sensory or mental capabilities, or lack of experience and knowledge, unless they have been given supervision or instruction concerning use of the appliance by a person responsible for their safety. Children should be supervised to ensure that they do not play with the appliance.
- To avoid danger of suffocation, keep the plastic bag or thin film used as the packaging material away from young children.
- The appliance shall be stored in a room without continuously operating ignition sources (for example: open flames, an operating gas appliance or an operating electric heater).
- Do not pierce or burn.
- Be aware that refrigerants may not contain an odor.
- Keep any required ventilation openings clear of obstruction.
- If the power cable or the connection cable is damaged, it must be replaced by the manufacturer, its service agent or similar qualified persons in order to avoid a safety hazard.
- After servicing, check for refrigerant leak before turning on the unit.
- Cancer and Reproductive Harm - www.P65Warnings.ca.gov.

⚠ CAUTION

- Read carefully all safety information written in this manual before you install or use the air conditioner.
- Do not attempt to install the air conditioner or a part of the air conditioner by yourself.
- This product must be installed by qualified personnel with a capacity certificate for handling refrigerant fluids. Refer to regulation and laws in use on installation place.
- Install the product by following local codes and regulations in force at the place of installation, and the instructions provided by the manufacturer.
- This product is part of a set constituting an air conditioner. The product must not be installed alone or be installed with a device not authorized by the manufacturer.
- Always use a separate power supply line protected by a circuit breaker operating on all wires with a distance between contact of 1/8 in (3 mm) for this product.
- To protect the persons, ground (earth) the product correctly, and use the power cable combined with an Earth Leakage Circuit Breaker (ELCB).
- This product is not explosion proof, and therefore should not be installed in an explosive atmosphere.
- To avoid getting an electric shock, never touch the electrical components soon after the power supply has been turned off. After turning off the power, always wait 5 minutes or more before you touch the electrical components.
- This product contains no user-serviceable parts. Always consult experienced service technicians for repairing.
- When moving or relocating the air conditioner, consult experienced service technicians for disconnection and reinstallation of the product.
- Do not touch the aluminum fins of heat exchanger built-in the indoor or outdoor unit to avoid personal injury when you install or maintain the unit.
- Do not place any other electrical products or household belongings under the product. Condensation dripping from the product might get them wet, and may cause damage or malfunction to the property.
- Do not use flammable substances (such as pesticides and hair sprays). Doing so may cause an electric shock, fire or wrong detection by the refrigerant sensor.
- This product is equipped with a refrigerant leakage sensor. Do not install the product at a location filled with smoke, gases or chemicals.
- After installation is complete, explain to the customer that the breaker must be always turned on to ensure the operation of the refrigerant leakage sensor.
- When connecting the pipes, be careful not to allow the refrigerant to be leaked. If the refrigerant is sprayed directly onto the sensor, the sensor may fail.
- Be careful not to scratch the air conditioner when handling it.

2. PRODUCT SPECIFICATION

2.1. Precautions for using R32 refrigerant

The basic installation work procedures are the same as conventional refrigerant (R410A, R22) models.

However, pay careful attention to the following points:

Since the working pressure is 1.6 times higher than that of refrigerant R22 models, some of the piping and installation and service tools are special. (Refer to "2.3. Installation tools".)

Especially, when replacing a refrigerant R22 model with a new refrigerant R32 model, always replace the conventional piping and flare nuts with the R32 and R410A piping and flare nuts on the outdoor unit side.

For R32 and R410A, the same flare nut on the outdoor unit side and pipe can be used.

Models that use refrigerant R32 and R410A have a different charging port thread diameter to prevent erroneous charging with refrigerant R22 and for safety. Therefore, check beforehand. [The charging port thread diameter for R32 and R410A is 1/2-20 UNF.]

Be more careful than R22 so that foreign matter (oil, water, etc.) does not enter the piping. Also, when storing the piping, securely seal the opening by pinching, taping, etc. (Handling of R32 is similar to R410A.)

When charging the refrigerant, take into account the slight change in the composition of the gas and liquid phases. And always charge from the liquid phase where refrigerant composition is stable.

This manual includes requirements of clauses according to Table DD.1 (Installation, Maintenance and repair, Decommissioning)

⚠ WARNING

- Auxiliary devices which may be a potential ignition source shall not be installed in the duct work.
- Examples of such potential ignition sources are hot surfaces with a temperature exceeding 1292°F (700°C) and electric switching devices.
- Minimum room area is corrected by multiplying by an altitude adjustment factor (AF) based on for building site ground level altitude (H_{alt}) in meters.

H_{alt}	0	200	400	600	800	1000	1200	1400	1600
AF	1.00	1.00	1.00	1.00	1.02	1.05	1.07	1.10	1.12
H_{alt}	1600	1800	2000	2200	2400	2600	2800	3000	3200
AF	1.12	1.15	1.18	1.21	1.25	1.28	1.32	1.36	1.40

- The appliance shall not be installed in an unventilated space, if that space is smaller than minimum installation area.
- **RISK OF FIRE:** This unit is equipped with a refrigerant leak detection system for safety and with electrically powered safety measures. To be effective, the unit must be electrically powered at all times after installation, other than when servicing.
- If the ducted air conditioner is used to condition more than one room, then the minimum installation area on table below shall apply to the smallest room.
- Regarding the installation area for safety measures, if the desired minimum ceiling height is less than 7.2 ft (2.2 m), the minimum installation area must be re-calculated accordingly.
- When the safety measure is enabled, the safety measure-compatible installation area will be applied.
- For more information about safety measure settings, refer to "5. FUNCTION SETTING".

(UL60335-2-40) Without safety measures

Amount of refrigerant charge M [lbs (kg)]	Minimum room area X [ft ² (m ²)]
$M \leq 4.05(1.836)$	-
$4.05(1.836) < M \leq 4.19(1.90)$	222.79(20.70)
$4.19(1.90) < M \leq 4.41(2.00)$	234.51(21.79)
$4.41(2.00) < M \leq 4.63(2.10)$	246.24(22.88)
$4.63(2.10) < M \leq 4.85(2.20)$	257.97(23.97)
$4.85(2.20) < M \leq 5.07(2.30)$	269.69(25.06)
$5.07(2.30) < M \leq 5.29(2.40)$	281.42(26.15)
$5.29(2.40) < M \leq 5.51(2.50)$	293.14(27.24)
$5.51(2.50) < M \leq 5.73(2.60)$	304.87(28.33)
$5.73(2.60) < M \leq 5.95(2.70)$	316.59(29.42)
$5.95(2.70) < M \leq 6.17(2.80)$	328.32(30.51)
$6.17(2.80) < M \leq 6.39(2.90)$	340.04(31.60)
$6.39(2.90) < M \leq 6.61(3.00)$	351.77(32.68)
$6.61(3.00) < M \leq 6.83(3.10)$	363.50(33.77)
$6.83(3.10) < M \leq 7.05(3.20)$	375.22(34.86)
$7.05(3.20) < M \leq 7.28(3.30)$	386.95(35.95)
$7.28(3.30) < M \leq 7.50(3.40)$	398.67(37.04)
$7.50(3.40) < M \leq 7.72(3.50)$	410.40(38.13)
$7.72(3.50) < M \leq 7.94(3.60)$	422.12(39.22)
$7.94(3.60) < M \leq 8.16(3.70)$	433.85(40.31)
$8.16(3.70) < M \leq 8.38(3.80)$	445.57(41.40)
$8.38(3.80) < M \leq 8.60(3.90)$	457.30(42.49)
$8.60(3.90) < M \leq 8.82(4.00)$	469.02(43.58)

⚠ WARNING**(UL60335-2-40) With safety measures**

This table shows the minimum floor area required for installation in ceiling height of 7.2 ft (2.2 m) or higher.

Amount of refrigerant charge M [lbs (kg)]	Minimum room area X [ft ² (m ²)]
M ≤ 4.05(1.836)	-
4.05(1.836) < M ≤ 4.19(1.90)	60.76(5.65)
4.19(1.90) < M ≤ 4.41(2.00)	63.96(5.95)
4.41(2.00) < M ≤ 4.63(2.10)	67.16(6.24)
4.63(2.10) < M ≤ 4.85(2.20)	70.36(6.54)
4.85(2.20) < M ≤ 5.07(2.30)	73.56(6.84)
5.07(2.30) < M ≤ 5.29(2.40)	76.75(7.14)
5.29(2.40) < M ≤ 5.51(2.50)	79.95(7.43)
5.51(2.50) < M ≤ 5.73(2.60)	83.15(7.73)
5.73(2.60) < M ≤ 5.95(2.70)	86.35(8.03)
5.95(2.70) < M ≤ 6.17(2.80)	89.55(8.32)
6.17(2.80) < M ≤ 6.39(2.90)	92.74(8.62)
6.39(2.90) < M ≤ 6.61(3.00)	95.94(8.92)
6.61(3.00) < M ≤ 6.83(3.10)	99.14(9.21)
6.83(3.10) < M ≤ 7.05(3.20)	102.34(9.51)
7.05(3.20) < M ≤ 7.28(3.30)	105.53(9.81)
7.28(3.30) < M ≤ 7.50(3.40)	108.73(10.11)
7.50(3.40) < M ≤ 7.72(3.50)	111.93(10.40)
7.72(3.50) < M ≤ 7.94(3.60)	115.13(10.70)
7.94(3.60) < M ≤ 8.16(3.70)	118.33(11.00)
8.16(3.70) < M ≤ 8.38(3.80)	121.52(11.29)
8.38(3.80) < M ≤ 8.60(3.90)	124.72(11.59)
8.60(3.90) < M ≤ 8.82(4.00)	127.92(11.89)

- Ducts connected to this product shall not contain a potential ignition source such as hot surfaces, flames or current carrying devices that can be the source of arcing or sparking.
- Where the indoor unit is connected via an air duct system to one or more rooms, the supply and return air shall be directly ducted to the space. Open areas such as false ceilings must not be used as a return air duct. And when using auxiliary devices, it shall be installed that is declared suitable with R32 refrigerant in connecting ductwork.

⚠ CAUTION**1. General****1-1 Installation**

- That pipe work including piping material, pipe routing, and installation shall include protection from physical damage in operation and service, and be in compliance with national and local codes and standards, such as ASHRAE 15, ASHRAE 15.2, IAPMO Uniform Mechanical Code, ICC International Mechanical Code, or CSA B52. All field joints shall be accessible for inspection prior to being covered or enclosed.
- That after completion of field piping for split systems, the field pipework shall be pressure tested with an inert gas and then vacuum tested prior to refrigerant charging, according to the following requirements:
The minimum test pressure for the low side of the system shall be the low side design pressure and the minimum test pressure for the high side of the system shall be the high side design pressure, unless the high side of the system, cannot be isolated from the low side of the system in which case the entire system shall be pressure tested to the low side design pressure.

- Field-made refrigerant joints indoors shall be tightness tested. The test method shall have a sensitivity of 5 grams per year of refrigerant or better under a pressure of at least 0.25 times the maximum allowable pressure. No leak shall be detected;

1-2 Unventilated areas

- When installing this product to an unventilated area, pay attention to prevent fire and explosion caused by the stagnated gas in case of refrigerant leakage. (For products which contain more than 1.836 kg refrigerant.)
- The appliance shall be stored so as to prevent mechanical damage from occurring.

1-3 Qualification of workers

- As this product uses flammable refrigerant, its installation, repair, maintenance, removal, and deposition must be performed by dedicated service personnel who completed trainings and obtained relevant certificates provided by the domestic training facilities or manufactures certified for obtaining relevant national certificate stipulated by the applicable law.

2. Information on servicing

(Checks to the area)

- Prior to beginning work on systems containing flammable refrigerants, safety checks are necessary to ensure that the risk of ignition is minimized.
- For repair to the refrigerating system, 2-1 to 2-5 shall be completed prior to conducting work on the system

2-1 Work procedure

- Work shall be undertaken under a controlled procedure so as to minimize the risk of a flammable gas or vapor being present while the work is being performed.

2-2 General work area

- All maintenance staff and others working in the local area shall be instructed on the nature of work being carried out.
- Work in confined spaces shall be avoided.

2-3 Checking for presence of refrigerant

- The area shall be checked with an appropriate refrigerant detector prior to and during work, to ensure the technician is aware of potentially toxic or flammable atmospheres.

⚠ CAUTION

- Ensure that the leak detection equipment being used is suitable for use with all applicable refrigerants, i.e. non-sparking, adequately sealed or intrinsically safe.

2-4 Presence of fire extinguisher

- If any hot work is to be conducted on the refrigerating equipment or any associated parts, appropriate fire extinguishing equipment shall be available to hand.
- Have a dry powder or CO₂ fire extinguisher adjacent to the charging area.

2-5 No ignition sources

- No person carrying out work in relation to a refrigerating system which involves exposing any pipe work shall use any sources of ignition in such a manner that it may lead to the risk of fire or explosion.
- All possible ignition sources, including cigarette smoking, should be kept sufficiently far away from the site of installation, repairing, removing and disposal, during which refrigerant can possibly be released to the surrounding space. Prior to work taking place, the area around the equipment is to be surveyed to make sure that there are no flammable hazards or ignition risks. "No Smoking" signs shall be displayed.

2-6 Ventilated area

- Ensure that the area is in the open or that it is adequately ventilated before breaking into the system or conducting any hot work.
- A degree of ventilation shall continue during the period that the work is carried out.
- The ventilation should safely disperse any released refrigerant and preferably expel it externally into the atmosphere.

2-7 Checks to the refrigerating equipment

- Where electrical components are being changed, they shall be fit for the purpose and to the correct specification.
- At all times the manufacturer's maintenance and service guidelines shall be followed. If in doubt, consult the manufacturer's technical department for assistance.
- The following checks shall be applied to installations using flammable refrigerants :
 - the actual refrigerant charge is in accordance with the room size within which the refrigerant containing parts are installed;
 - the ventilation machinery and outlets are operating adequately and are not obstructed;
 - if an indirect refrigerating circuit is being used, the secondary circuit shall be checked for the presence of refrigerant;
 - marking to the equipment continues to be visible and legible. Markings and signs that are illegible shall be corrected;
 - refrigerating pipe or components are installed in a position where they are unlikely to be exposed to any substance which may corrode refrigerant containing components, unless the components are constructed of materials which are inherently resistant to being corroded or are suitably protected against being so corroded.

2-8 Checks to electrical devices

- Repair and maintenance to electrical components shall include initial safety checks and component inspection procedures.
- If a fault exists that could compromise safety, then no electrical supply shall be connected to the circuit until it is satisfactorily dealt with.
- If the fault cannot be corrected immediately but it is necessary to continue operation, an adequate temporary solution shall be used.
- This shall be reported to the owner of the equipment so all parties are advised.
- Initial safety checks shall include :
 - that capacitors are discharged: this shall be done in a safe manner to avoid possibility of sparking;
 - that there no live electrical components and wiring are exposed while charging, recovering or purging the system;
 - that there is continuity of earth bonding.

3. Repairs to sealed components

Sealed electrical components shall be replaced.

4. Repair to intrinsically safe components

Intrinsically safe components must be replaced.

5. Cabling

- Check that cabling will not be subject to wear, corrosion, excessive pressure, vibration, sharp edges or any other adverse environmental effects.
- The check shall also take into account the effects of aging or continual vibration from sources such as compressors or fans.

6. Detection of flammable refrigerants

- Under no circumstances shall potential sources of ignition be used in the searching for or detection of refrigerant leaks.
- A halide torch (or any other detector using a naked flame) shall not be used.

7. Leak detection methods

The following leak detection methods are deemed acceptable for all refrigerant systems.

- Electronic leak detectors may be used to detect refrigerant leaks but, in the case of flammable refrigerants, the sensitivity may not be adequate, or may need recalibration. (Detection equipment shall be calibrated in a refrigerant-free area.)
- Ensure that the detector is not a potential source of ignition and is suitable for the refrigerant used.

- Leak detection equipment shall be set at a percentage of the LFL of the refrigerant and shall be calibrated to the refrigerant employed, and the appropriate percentage of gas (25 % maximum) is confirmed.

- Leak detection fluids are also suitable for use with most refrigerants but the use of detergents containing chlorine shall be avoided as the chlorine may react with the refrigerant and corrode the copper pipe-work.

NOTE:

- Examples of leak detection fluids are
 - bubble method,
 - fluorescent method agents.
- If a leak is suspected, all naked flames shall be removed / extinguished.
- If a leakage of refrigerant is found which requires brazing, all of the refrigerant shall be recovered from the system, or isolated (by means of shut off valves) in a part of the system remote from the leak.

8. Removal and evacuation

- When breaking into the refrigerant circuit to make repairs – or for any other purpose – conventional procedures shall be used. However, for flammable refrigerants it is important that best practice is followed since flammability is a consideration.

The following procedure shall be adhered to :

- safely remove refrigerant following local and national regulations;
- evacuate;

⚠ CAUTION

- purge the circuit with inert gas (optional for R32);
- evacuate (optional for R32);
- continuously flush or purge with inert gas when using flame to open circuit; and
- open the circuit.
- The refrigerant charge shall be recovered into the correct recovery cylinders if venting is not allowed by local and national codes.
- For appliances containing flammable refrigerants, the system shall be purged with oxygen-free nitrogen to render the appliance safe for flammable refrigerants.
- This process might need to be repeated several times.
- Compressed air or oxygen shall not be used for purging refrigerant systems.
- For appliances containing flammable refrigerants, refrigerants purging shall be achieved by breaking the vacuum in the system with oxygen-free nitrogen and continuing to fill until the working pressure is achieved, then venting to atmosphere, and finally pulling down to a vacuum (optional for R32).
- This process shall be repeated until no refrigerant is within the system (optional for R32).
- When the final oxygen-free nitrogen charge is used, the system shall be vented down to atmospheric pressure to enable work to take place.
- The outlet for the vacuum pump is not close to any potential ignition sources and that ventilation is available.

9. Charging procedures

- In addition to conventional charging procedures, the following requirements shall be followed.
 - Ensure that contamination of different refrigerants does not occur when using charging equipment. Hoses or lines shall be as short as possible to minimize the amount of refrigerant contained in them.
 - Cylinders shall be kept in an appropriate position according to the instructions.
 - Ensure that the refrigerating system is earthed prior to charging the system with refrigerant.
 - Extreme care shall be taken not to overfill the refrigerating system.
- Prior to recharging the system, it shall be pressure tested with the appropriate purging gas.
- The system shall be leak tested on completion of charging but prior to commissioning.
- A follow up leak test shall be carried out prior to leaving the site.

10. Decommissioning

- Before carrying out this procedure, it is essential that the technician is completely familiar with the equipment and all its detail.
- It is recommended good practice that all refrigerants are recovered safely.
- Prior to the task being carried out, an oil and refrigerant sample shall be taken in case analysis is required prior to re-use of recovered refrigerant.
- It is essential that electrical power is available before the task is commenced.
 - a) Become familiar with the equipment and its operation.
 - b) Isolate system electrically.
 - c) Before attempting the procedure, ensure that:
 - mechanical handling equipment is available, if required, for handling refrigerant cylinders;
 - all personal protective equipment is available and being used correctly;
 - the recovery process is supervised at all times by a competent person;
 - recovery equipment and cylinders conform to the appropriate standards.
 - d) Pump down refrigerant system, if possible.
 - e) If a vacuum is not possible, make a manifold so that refrigerant can be removed from various parts of the system.
 - f) Make sure that cylinder is situated on the scales before recovery takes place.
 - g) Start the recovery machine and operate in accordance with instructions.
 - h) Do not overfill cylinders (no more than 80% volume liquid charge).
 - i) Do not exceed the maximum working pressure of the cylinder, even temporarily.
 - j) When the cylinders have been filled correctly and the process completed, make sure that the cylinders and the equipment are removed from site promptly and all isolation valves on the equipment are closed off.
 - k) Recovered refrigerant shall not be charged into another refrigerating system unless it has been cleaned and checked.





11. Labelling

- Equipment shall be labelled stating that it has been de-commissioned and emptied of refrigerant.
- The label shall be dated and signed.
- For appliances containing flammable refrigerants, ensure that there are labels on the equipment stating the equipment contains flammable refrigerant.

12. Recovery

- When removing refrigerant from a system, either for servicing or decommissioning, it is recommended good practice that all refrigerants are removed safely.
- When transferring refrigerant into cylinders, ensure that only appropriate refrigerant recovery cylinders are employed.
- Ensure that the correct number of cylinders for holding the total system charge are available.
- All cylinders to be used are designated for the recovered refrigerant and labelled for that refrigerant (i.e. special cylinders for the recovery of refrigerant).
- Cylinders shall be complete with pressure relief valve and associated shut-off valves in good working order.
- Empty recovery cylinders are evacuated and, if possible, cooled before recovery occurs.
- The recovery equipment shall be in good working order with a set of instructions concerning the equipment that is at hand and shall be suitable for the recovery of the flammable refrigerant. If in doubt, the manufacturer should be consulted. In addition, a set of calibrated weighing scales shall be available and in good working order.
- Hoses shall be complete with leak-free disconnect couplings and in good condition.
- The recovered refrigerant shall be returned to the refrigerant supplier in the correct recovery cylinder, and the relevant Waste Transfer Note arranged.
- Do not mix refrigerants in recovery units and especially not in cylinders.
- If compressors or compressor oils are to be removed, ensure that they have been evacuated to an acceptable level to make certain that flammable refrigerant does not remain within the lubricant.
- The compressor body shall not be heated by an open flame or other ignition sources to accelerate this process.
- When oil is drained from a system, it shall be carried out safely.

Explanation of symbols displayed on the indoor unit or outdoor unit.

	Refrigerant Safety Group A2L	WARNING This symbol shows that this product uses a low burning velocity material. If the refrigerant is leaked and exposed to an external ignition source, there is a risk of fire.
		CAUTION This symbol shows that the operation manual should be read carefully.
		CAUTION This symbol shows that a service personnel should be handling this equipment with reference to the installation manual.
		CAUTION This symbol shows that information is available such as the operation manual or installation manual.

2.2. Refrigerant leakage sensor

⚠ CAUTION

- This product is equipped with a refrigerant leakage sensor. Do not install the product at a location filled with smoke, gases or chemicals.
- When connecting the pipes, be careful not to allow the refrigerant to be leaked. If the refrigerant is sprayed directly onto the sensor, the sensor may fail.
- After installation is complete, explain to the customer that the breaker must be always turned on to ensure the operation of the refrigerant leakage sensor.
- Do not use flammable substances (such as pesticides and hair sprays). Doing so may cause an electric shock, fire or wrong detection by the refrigerant sensor.
- Do not use silicone fillers or sprays. Otherwise, it may cause sensor failure.
- When installing or refrigerant piping or drain piping, do not subject the sensor to shock or expose it to refrigerant or water. Otherwise, it may cause sensor failure.

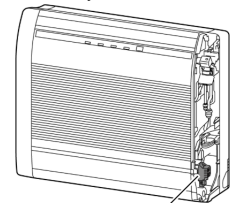

Refrigerant leakage sensor (located inside the side panel R)

Refrigerant leakage sensor have an expiration date

- The expiration date is 13 years, provided the sensor element is not affected by substances that degrade it.
- If the expiry date of the sensor is approaching or has passed, an error code will be shown. Refer to "9. ERROR CODES".
- Refrigerant leakage sensor that have passed their expiration date must be replaced.

Request replacement of the refrigerant leakage sensor to your dealer or authorized service personnel.

2.3. Installation tools

Tool name	Change from R22 to R32 (R410A)
Gauge manifold	Pressure is high and cannot be measured with a R22 gauge. To prevent erroneous mixing of other refrigerants, the diameter of each port has been changed. It is recommended to use gauge with seals -0.1 to 5.3 MPa (-1 to 53 bar) for high pressure. -0.1 to 3.8 MPa (-1 to 38 bar) for low pressure.
Charge hose	To increase pressure resistance, the hose material and base size were changed. (R32/R410A)
Vacuum pump	A conventional vacuum pump can be used by installing a vacuum pump adapter. (Use of a vacuum pump with a series motor is prohibited.)
Gas leakage detector	Special gas leakage detector for HFC refrigerant R410A or R32.

● Copper pipes

It is necessary to use seamless copper pipes and it is desirable that the amount of residual oil is less than 0.004 oz/100 ft. (40 mg/10 m).
Do not use copper pipes having a collapsed, deformed or discolored portion (especially on the interior surface).
Otherwise, the expansion valve or capillary tube may become blocked with contaminants.
As an air conditioner using R32 (R410A) incurs pressure higher than when using R22, it is necessary to choose adequate materials.

⚠ WARNING

- Do not use the existing (for R22) piping and flare nuts. If the existing materials are used, the pressure inside the refrigerant cycle will rise and cause failure, injury, etc. (Use the special R32/R410A materials.)
- Use (refill or replace with) specified refrigerant (R32) only. Use of unspecified refrigerant can cause product malfunction, burst, or injury.
- Do not mix any gas or impurities except specified refrigerant (R32). Inflow of air or application of unspecified material makes the internal pressure of the refrigerant cycle too high, and may cause product malfunction, burst of piping, or injury.
- For installation purposes, be sure to use the parts supplied by the manufacturer or other prescribed parts. The use of non-prescribed parts can cause serious accidents such as the unit falling, water leakage, electric shock, or fire.

⚠ WARNING

- Do not turn on the power until all work has been completed.

⚠ CAUTION

This manual describes how to install the indoor unit only. To install the outdoor unit or branch box, (if any), refer to the installation manual included in each product.

2.4. For authorized service personnel only.

⚠ WARNING

- For appropriate working of the air conditioner, install it as outlined in this manual.
- To connect the indoor unit and outdoor unit or branch box, use air conditioner piping and cables available through your local distributor. This manual describes proper connections using such installation set.
- Do not reconnect the power until all work has been completed.







⚠ CAUTION

This installation manual describes how to install the indoor unit only. To install the outdoor unit or branch box, refer to the installation manual included with the outdoor unit or branch box.

- Be careful not to scratch the air conditioner when handling it.
- After installation, explain correct operation to the customer, using the operation manual.

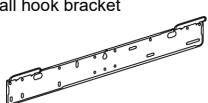
2.5. Accessories

The following installation accessories are supplied. Use them as required.

Name and Shape	Qty	Name and Shape	Qty
 Operation manual	1	 Installation manual (This manual)	1
 Self-tapping screw	9	 Wall hook bracket	1
 Cloth tape	1	 Cable tie	1
 Ion deodorization filter (light blue)	1	 Apple-catechin filter (White)	1

The following items are necessary to install this air conditioner. (The items are not included with the air conditioner and must be purchased separately.)

Additional materials

Connection pipe assembly	Wall cap	Connection cable (4-conductor)
Saddle	Wall pipe	Drain hose
Decorative tape	Self-tapping screws	Vinyl tape
Putty	Sealant	Refrigeration (armored) tape
Insulated staples or clamps for connecting wire (refer to your electrical cables.)	Clamps or saddles to secure refrigerant piping	Refrigeration lubricant

2.6. Pipe requirement

⚠ CAUTION

Refer to the installation manual for the outdoor unit for description of allowable pipe length and height difference.

Liquid pipe size [thickness]	Gas pipe size [thickness]
Ø 1/4 in (Ø 6.35 mm) [0.031 in (0.80 mm)]	Ø 3/8 in (Ø 9.52 mm) [0.031 in (0.80 mm)]

⚠ CAUTION

Install heat insulation around both the gas and liquid pipes. Failure to do so may cause water leaks.
Use heat insulation with heat resistance above 248 °F (120 °C). Reverse cycle model only.
In addition, if the humidity level at the installation location of the refrigerant piping is expected to exceed 70%, install heat insulation around the refrigerant piping. If the expected humidity level is 70-80%, use heat insulation that is 3/4 in (15 mm) or thicker and if the expected humidity exceeds 80%, use heat insulation that is 13/16 in (20 mm) or thicker.

⚠ CAUTION

If heat insulation is used that is not as thick as specified, condensation may form on the surface of the insulation. In addition, use heat insulation with heat conductivity of 0.045 W/(m·K) or less (at [68 °F (20 °C)]).

2.7. Electrical requirement

The indoor unit is powered from the outdoor unit or branch box. Do not power indoor unit from separate power source.

⚠ WARNING

- Standard for electrical wiring and equipment differs in each country or region. Before you start electrical working, confirm related regulations, codes, or standards.
- Be sure to install a breaker of the specified capacity (for outdoor unit).

Cable	Conductor size	Remarks
Connection Cable	14AWG	3 cable + Ground (Earth)

Max. Cable Length: Limit the voltage drop to less than 2%. Increase the cable diameter if voltage drop is 2% or more.

2.8. Optional parts

Refer to each installation manual for the method of installing optional parts.

Parts name	Model No.	Application
Wireless remote controller	UTY-LNXUZ1	For air conditioner operation
Wired remote controller (*1)	UTY-RVRU UTY-RNRUZ*	For air conditioner operation (2-wired type)
Simple remote controller (*1)	UTY-RSRY UTY-RSRYZ* UTY-RHRY UTY-RHRYZ*	For air conditioner operation (2-wired type)
External connect kit	UTY-XWZX5 UTY-XWZX	For control input/output port
Communication kit	UTY-TWRXZ3	For the installation of 2-wired remote controller
Half concealed kit	UTR-STA	For air conditioner operation
Thermostat convertor (*1)	UTY-TTRXZ*	For air conditioner operation
Network converter (*1)	UTY-VTGX	For air conditioner operation
Modbus converter	UTY-VMSX	Only one communication converter can be connected.
External switch controller (*1)	UTY-TERX	For air conditioner operation

* Optional parts are subject to change without notice.

*1: Optional Communication kit (UTY-TWRXZ3) is necessary for installation.

3. INSTALLATION WORK

3.1. Selecting an installation location

Decide the mounting position with the customer as follows:

- Install the indoor unit level on a strong wall which is not subject to vibration.
- The inlet and outlet ports should not be obstructed: the air should be able to blow all over the room.
- Install the unit a dedicated electrical branch circuit.
- Do not install the unit where it will be exposed to direct sunlight.
- Install the unit where connection to the outdoor unit is easy.
- Install the unit where the drain pipe can be easily installed.
- Take servicing, etc. into consideration and leave the spaces shown in "3.1.1. Installation dimensions". Also install the unit where the filter can be removed.

Correct initial installation location is important because it is difficult to move the unit after it is installed.

⚠ WARNING

- Install the air conditioner in a location which can withstand a load of at least 3 times the weight of the main unit and which will not amplify sound or vibration. If the installation location is not strong enough, the indoor unit may fall and cause injuries.

Withstandable weight (Unit weight x 3*)
93 lbs (42 kg)

*In accordance with UL standards.

- Since this product is equipped with a refrigerant leakage sensor, embedded installation (with grating) is prohibited.
- Installing a grating may not be able to agitate the refrigerant sufficiently when the refrigerant is leaked.

⚠ CAUTION

- Do not install the unit in the following areas:
 - Area with high salt content, such as at the seaside. It will deteriorate metal parts, causing the parts to fail or the unit to leak water.
 - Area filled with mineral oil or containing a large amount of splashed oil or steam, such as a kitchen. It will deteriorate plastic parts, causing the parts to fail or the unit to leak water.
 - Area where is close to heat sources.
 - Area that generates substances that adversely affect the equipment, such as sulfuric gas, chlorine gas, acid, or alkali. It will cause the copper pipes and brazed joints to corrode, which can cause refrigerant leakage.
 - Area that can cause combustible gas to leak, contains suspended carbon fibers or flammable dust, or volatile in flammables such as paint thinner or gasoline.
 - If gas leaks and settles around the unit, it can cause a fire.

⚠ CAUTION

- Area where animals may urinate on the unit or ammonia may be generated.
- Do not use the unit for special purposes, such as storing food, raising animals, growing plants, or preserving precision devices or art objects. It can degrade the quality of the preserved or stored objects.
- Install the unit where drainage does not cause any trouble.
- Install the indoor unit, outdoor unit, power supply cable, transmission cable, and remote control cable at least 40 in (1m) away from a television or radio receivers. The purpose of this is to prevent TV reception interference or radio noise. (Even if they are installed more than 40 in (1m) apart, you could still receive noise under some signal conditions.)
- If children under 10 years old may approach the unit, take preventive measures so that they cannot reach the unit.

3.1.1. Installation dimensions

Keep the distance between the wall hook bracket or indoor unit to the surrounding walls as indicated in the following figure.

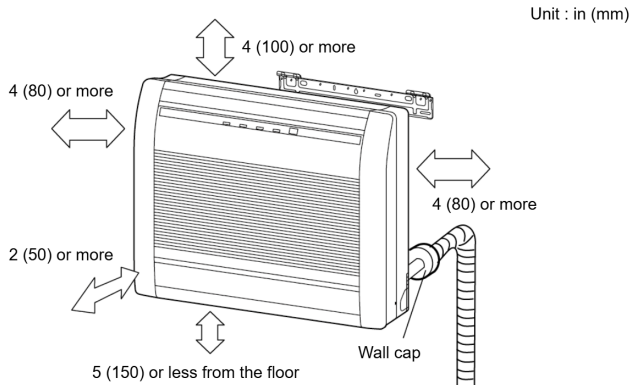

3.1.2. Embedding the indoor unit in a wall

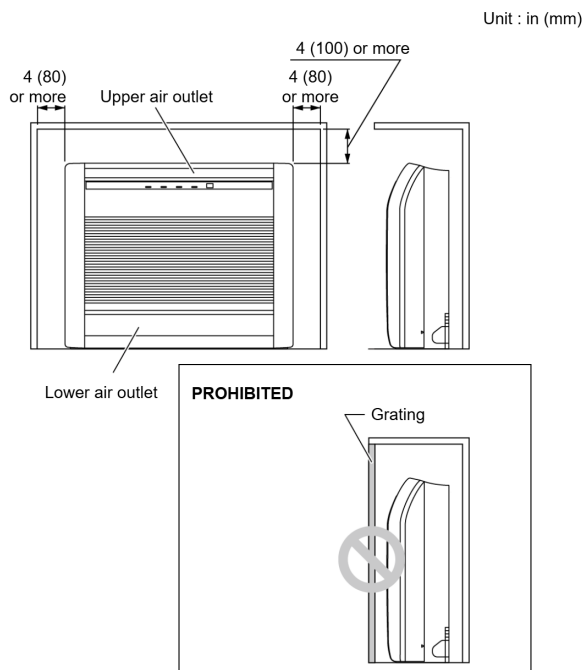

When embedding the indoor unit in a wall, restrict the movement of the horizontal louver for the upper air outlet so that it only operates horizontally. If this setting is not performed, heat will build up in the wall and the room will not be cooled or warmed properly.

NOTE:

- Explain the louver setting of direction only horizontally to the customer.

3.1.3. How to setting louver

Perform the "FUNCTION SETTING" according to the installation condition using the remote controller. Please refer to "5. FUNCTION SETTING".

3.2. Side panel L, R removal and installation

■ The intake grille removal

- (1) Open the intake grille.
- (2) Remove the rope.
- (3) Lay down the intake grille, until the axle at the bottom of the intake grille is removed.

■ The intake grille installation

- (1) The fixing axle of the intake grille is installed on the Panel.
- (2) Lift the intake grille upward.

■ The side panel L, R removal

- (1) Remove intake grille (Reference the intake grille removal.)
- (2) Remove 4 screws.
- (3) The middle finger is hung on the lower part as shown in the figure, and it pulls to the front, pushing [▶] mark, and bottom hooks (2 position) is removed from Base.
- (4) The side panel is pulled to the front, raising the upper surface, and a side panel is removed.

■ The side panel L, R installation

- (1) Firstly, fit the top part of the side panel, and insert top and bottom hooks.
- (2) 4 screws is attached.
- (3) The intake grille is attached.

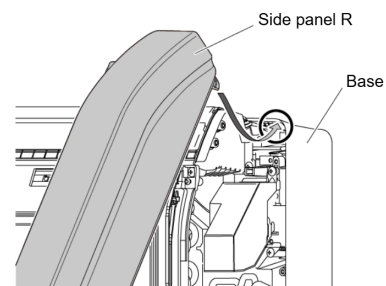
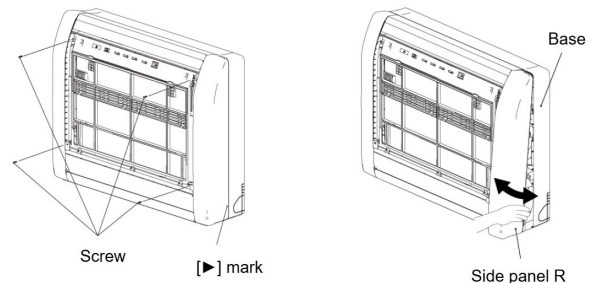
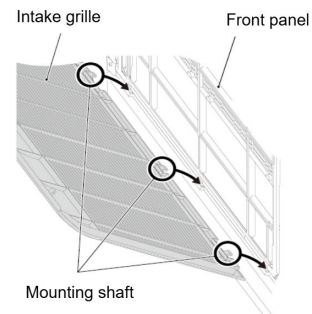
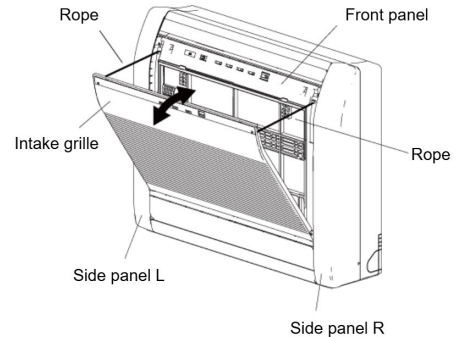

⚠ CAUTION

Install the side panel L, R and intake grille securely. If installation is imperfect, the side panel L, R or intake grille may fall off and cause injury.

3.3. Pipe installation

3.3.1. Indoor unit piping direction

The piping can be connected in the 6 directions indicated by (1), (2), (3), (4), (5) and (6) in the figure. When the piping is connected in direction (2) or (5), cut along the piping groove in the side of the base with a hacksaw.

When connecting the piping in direction (3), (6) cut a notch in the thin wall at the front bottom of the base.

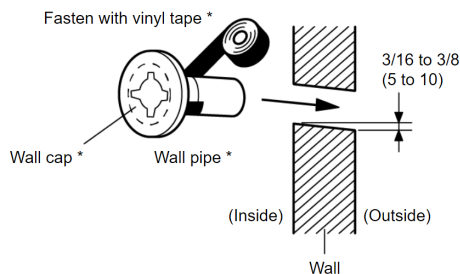
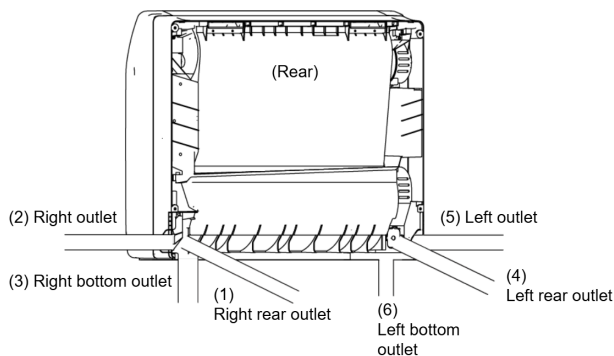

*Locally purchased

3.3.2. Cutting the hole in the wall for connecting the pipes

- (1) Cut a 2-5/16 in (65 mm) diameter hole in the wall at the position shown in the following.
- (2) Cut the hole so that the outside end is lower (3/16 to 3/8 in [5 to 10 mm]) than the inside end.
- (3) Always align the center of the wall hole. If misaligned, water leakage will occur.
- (4) Cut the wall pipe to match the wall thickness, stick it into the wall cap, fasten the cap with vinyl tape, and stick the pipe through the hole.
- (5) For the left piping and the right piping, cut the hole a little lower so that drain water will flow freely.

■ For right rear or left rear piping

(The following figure is a front view of the indoor unit installation location.)

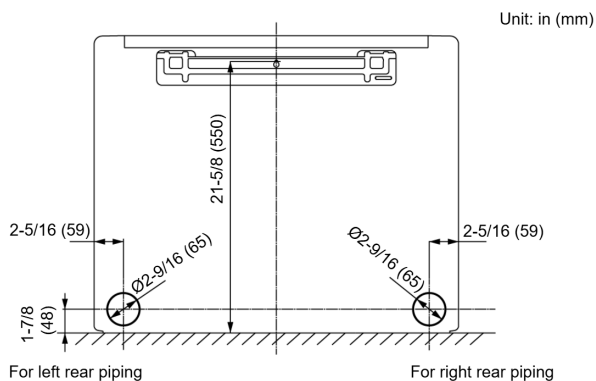

■ For right or left piping

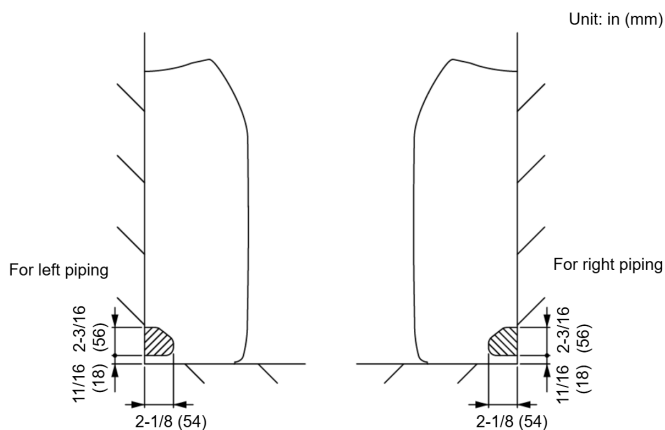

■ For right bottom or left bottom piping

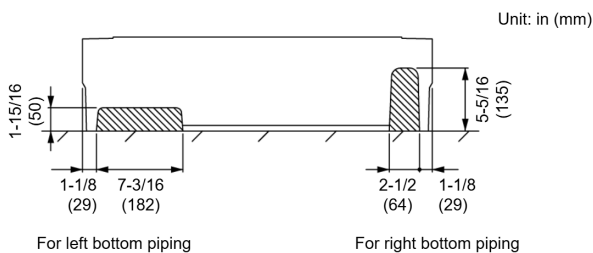

⚠ WARNING

Always use the wall pipe. If the wall pipe is not used, the cable that is connected between the indoor unit and the outdoor unit may touch metal, and cause an electric leak.

3.3.3. Indoor unit installation

- Use the included and fasten the indoor unit at 4 locations (→) each at top and the middle of the unit.
- When the unit is set to the wall, use the wall hook bracket and hook the top of the indoor unit on the indoor unit wall hook bracket.

Unit: in (mm)

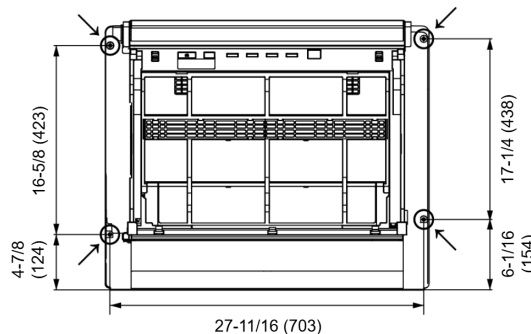

⚠ WARNING

- Fix the indoor unit with 4 screws surely. If improperly installed, might cause to injury due to the toppling or falling.
- Install the indoor unit at the place that has adequate strength. Install the indoor unit so that the installed unit can withstand the weight of adult body weight. If improperly installed, might cause accidental injury due to the toppling or falling.

3.3.4. Installing the wall hook bracket

- (1) Install the wall hook bracket so that it is correctly positioned horizontally and vertically. If the wall hook bracket is tilted, water will drip to the floor.
 - (2) Install the wall hook bracket so that it is strong enough to support the weight of the unit.
- Fasten the wall hook bracket to the wall with 5 or more screws through the holes near the outer edge of the bracket.
 - Check that there is no rattle at the wall hook bracket.

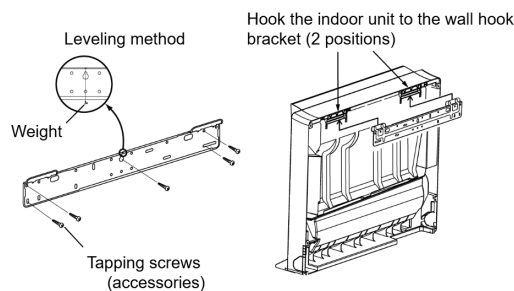

⚠ CAUTION

Install the wall hook bracket level, both horizontally and vertically.

3.3.5. Forming the drain hose and pipe

⚠ CAUTION

- Insert drain hose and drain cap securely. Drain should slope down to avoid water leakage.
- When inserting the drain hose, no other material than water should be applied. Application of other material than water will cause deterioration of the hose, and may cause water leakage.
- After you remove a drain hose, be sure to attach the drain cap.
- When you secure the piping and drain hose with tape, arrange the drain hose so that it is at the bottom of the piping.
- For drain hose piping in low temperature environment, you need to apply freeze protection to prevent a frozen drain hose. After cooling operation is performed in low temperature environment (when outdoor temperature under 32 °F [0 °C]), water in the drain hose could be frozen. Frozen drain water will block the water flow in the hose, and may cause water leakage at the indoor unit.

- (1) Pass the refrigerant pipe through the piping hole to indoor side.

(2) Arrange the pipes according to the direction of piping.

● **Rear piping**

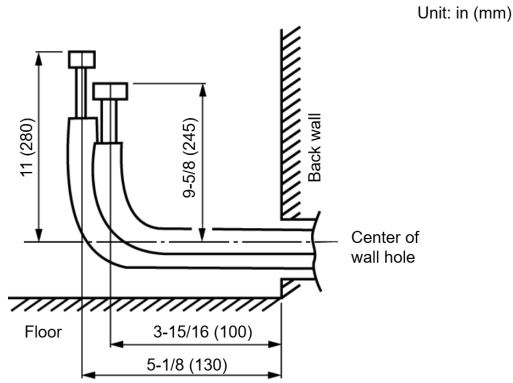

■ **Installing the drain cap**

Use a hexagonal wrench 4 mm at opposite side to insert the drain cap, till the drain cap contacts the tip of the drain cock.

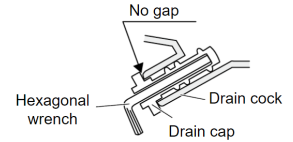

CAUTION

Insert the drain hose and drain cap into the drain port, making sure that it comes in contact with the back of the drain port, and then mount it. If the drain hose is not connected properly, leaking will occur.

3.3.6. **Pipe connection**

CAUTION

Tighten the flare nuts with a torque wrench using the specified tightening method. Otherwise, the flare nuts could break after a prolonged period, causing refrigerant to leak and generate hazardous gas if the refrigerant comes into contact with a flame.

■ **Flaring**

Use special pipe cutter and flare tool designed for R410A or R32 pipework.

- (1) Cut the connection pipe to the necessary length with a pipe cutter.
- (2) Hold the pipe downward so that cuttings will not enter the pipe and remove any burrs.
- (3) Insert the flare nut (always use the flare nut attached to the indoor unit(s) and outdoor unit or branch box respectively) onto the pipe and perform the flare processing with a flare tool. Use the special R410A or R32 flare tool, or the conventional flare tool. Leakage of refrigerant may result if other flare nuts are used.
- (4) Protect the pipes by pinching them or with tape to prevent dust, dirt, or water from entering the pipes.

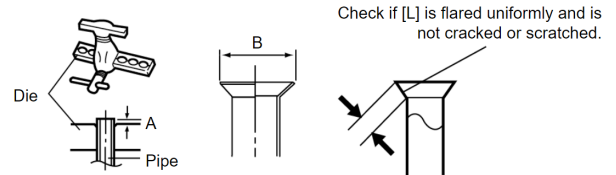

● **Left piping**

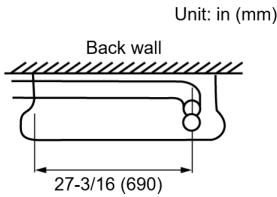

● **Right piping**

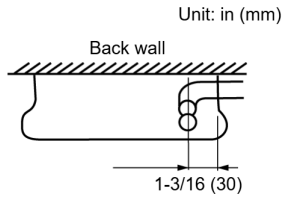

■ **Left and right replacement of drain hose**

The drain hose can be connected at either side of the indoor unit. The unit has been shipped with the drain hose connected at left (viewed from the back of the unit) and the drain cap applied at right.

- (1) Remove the both side panels.
- (2) Remove the screw and remove the drain holder from drain pan.
- (3) Pull out the drain cap.
- (4) Connect the drain hose to the right, attach the screw and insert the drain cap to the left.

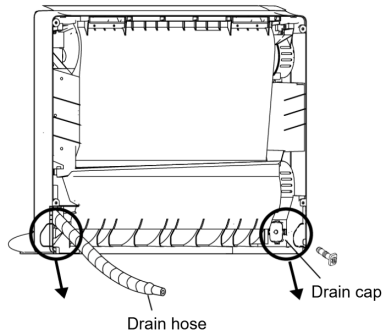

Pipe outside diameter [in (mm)]	Dimension A [in (mm)]	Dimension B [in (mm)]
	Flare tool for R32, clutch type	
1/4 (6.35)	0 to 0.020 (0 to 0.5)	3/8 (9.1)
3/8 (9.52)	0 to 0.020 (0 to 0.5)	1/2 (13.2)
1/2 (12.70)	0 to 0.020 (0 to 0.5)	5/8 (16.6)
5/8 (15.88)	0 to 0.020 (0 to 0.5)	3/4 (19.7)
3/4 (19.05)	0 to 0.020 (0 to 0.5)	15/16 (24.0)

When using conventional flare tools to flare R32 pipes, the dimension A should be approximately 0.5 mm more than indicated in the table (for flaring with R32 flare tools) to achieve the specified flaring. Use a thickness gauge to measure the dimension A.

Width across flats



Pipe outside diameter [in (mm)]	Width across flats of flare nut [in (mm)]
1/4 (6.35)	11/16 (17)
3/8 (9.52)	7/8 (22)
1/2 (12.70)	1 (26)
5/8 (15.88)	1-1/8 (29)
3/4 (19.05)	1-7/16 (36)

NOTE: The flare nut specification is compliant with ISO14903.

■ **Bending pipes**

CAUTION

- To prevent breaking of the pipe, avoid sharp bends.
- If the pipe is bent repeatedly at the same place, it will break.

- The pipes are shaped by your hands. Be careful not to collapse them.
- Bend R2-3/4 in (R70 mm) or more with a pipe bender.
- Do not bend the pipes in an angle more than 90°.
- When pipes are repeatedly bent or stretched, the material will harden, making it difficult to bend or stretch them anymore.
- Do not bend or stretch the pipes more than 3 times.
- When bending the pipe, do not bend it as is. The pipe will be collapsed. In this case, cut the insulating pipe with a sharp cutter as shown on the right, and bend it after exposing the pipe. After bending the pipe as you want, be sure to put the heat insulating pipe back on the pipe, and secure it with tape.

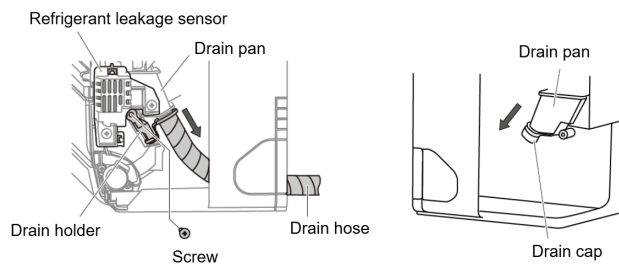
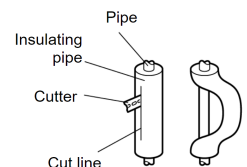

NOTE:

- When attaching/removing the drain holder and drain hose on the refrigerant leakage sensor side, be very careful not to give a shock to the sensor.

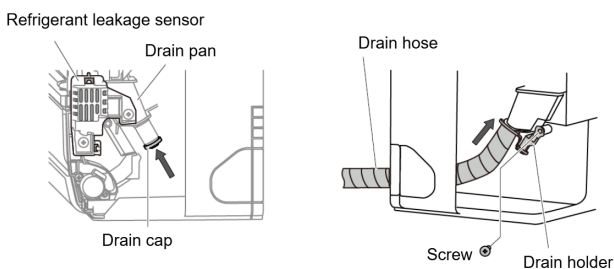

■ Flare connection

CAUTION

- Be sure to install the pipe against the port on the indoor unit correctly. If the centering is improper, the flare nut cannot be tightened smoothly. If the flare nut is forced to turn, the threads will be damaged.
- Do not remove the flare nut from the indoor unit pipe until immediately before connecting the connection pipe.
- Hold the torque wrench at its grip, keeping it in the right angle with the pipe, in order to tighten the flare nut correctly.
- Tighten the flare nuts with a torque wrench using the specified tightening method. Otherwise, the flare nuts could break after a prolonged period, causing refrigerant to leak and generate hazardous gas if the refrigerant comes into contact with a flame.
- Connect the piping so that the control box cover can easily be removed for servicing when necessary.
- In order to prevent water from leaking into the control box, make sure that the piping is well insulated.

When the flare nut is tightened properly by your hand, hold the body side coupling with a wrench, then tighten with a torque wrench. (Refer to the following table for the flare nut tightening torques.)

Tighten with 2 wrenches.

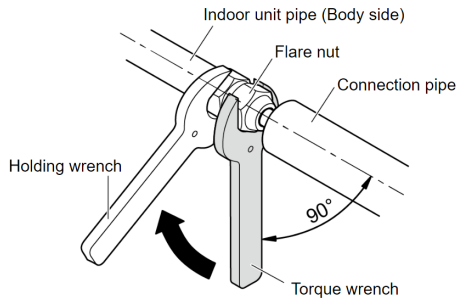

Flare nut [in (mm)]	Tightening torque [lbf-ft (N·m)]
1/4 (6.35) dia.	11.8 to 13.3 (16 to 18)
3/8 (9.52) dia.	23.6 to 31.0 (32 to 42)
1/2 (12.70) dia.	36.1 to 45.0 (49 to 61)
5/8 (15.88) dia.	46.5 to 55.3 (63 to 75)
3/4 (19.05) dia.	66.4 to 81.1 (90 to 110)

Do not remove the cap from the connection pipe before connecting the pipe.

3.4.1. Wiring system diagram

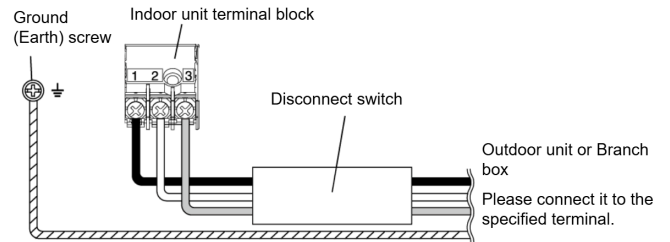
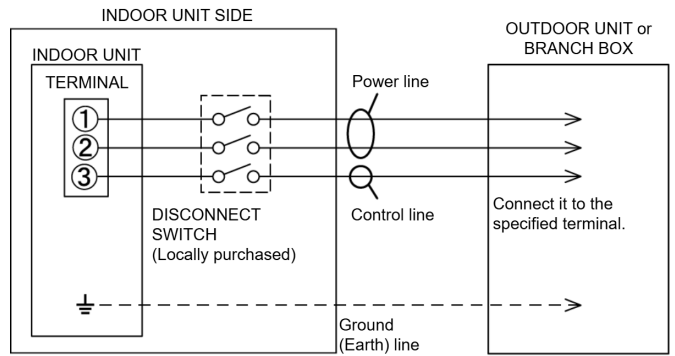

- To connect the indoor unit wires to the terminal correctly, refer to the figure for proper length.

Unit: in (mm)

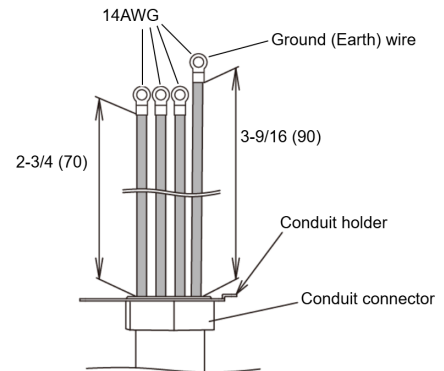

3.4.2. How to install the connection cable

- (1) Fasten the indoor unit wire harness to the conduit holder using the lock nut.
IMPORTANT: Refer to 3.4.1. Wiring system diagram about the length of indoor unit wire harness.
- (2) Remove the screws, then remove the cable clamer.
- (3) Connect indoor unit wire harness to the terminal.
Refer to 3.4.1. Wiring system diagram.
- (4) Use the screws to install the cable clamer.

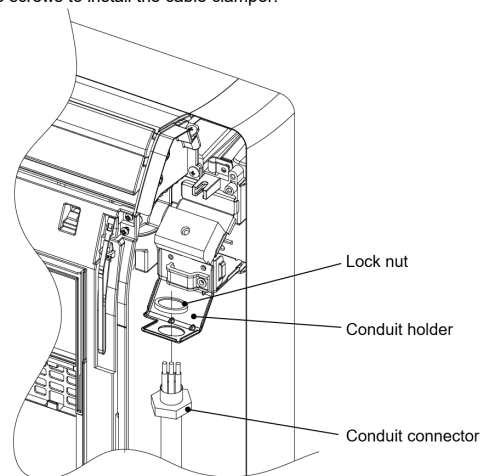

3.4.3. Indoor unit wiring

- (1) Remove the terminal cover.
- (2) Remove the cable clamer.
- (3) Bend the end of the connection cable as shown in the figure.
- (4) Connect the end of the connection cable fully into the terminal block.
- (5) Fasten the connection cable with a cable clamp.

3.4. Electrical wiring

WARNING

- Before wiring, make sure the power supply is OFF.
- Every wire must be connected firmly.
- No wire should be allowed to touch refrigerant tubing, the compressor, or any moving part.
- Loose wiring may cause the terminal to overheat or result in unit malfunction. A fire hazard may also exist. Therefore, be sure all wiring is tightly connected.
- Connect wires to the matching numbers of terminals.

CAUTION

- Be careful not to generate a spark as follows for using a flammable refrigerant.
- Do not remove the fuse while the power is on.
- Do not disconnect the wiring while the power is on.
- It is recommended to position the outlet connection in a high position. Place the cords so that they do not get tangled.

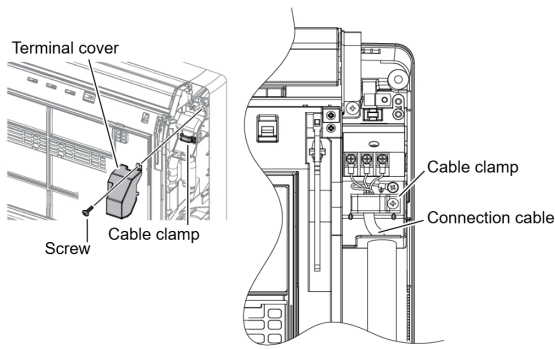

3.4.4. How to connect wiring to the terminals

■ Caution when wiring cable

To strip off the insulation of a lead wire, always use a special tool such as a wire stripper. If there is no special tool, carefully strip off the insulation by using a knife or other utensil.

- (1) Use ring terminals with insulating sleeves as shown in the figure to connect to the terminal block.
- (2) Securely clamp the ring terminals to the wires by using an appropriate tool so that the wires do not come loose.

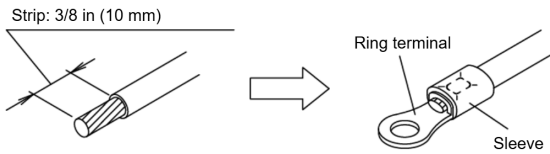

- (3) Use the specified wires, connect them securely, and fasten them so that there is no stress placed on the terminals.
- (4) Use an appropriate screwdriver to tighten the terminal screws. Do not use a screwdriver that is too small, otherwise, the screw heads may be damaged and prevent the screws from being properly tightened.
- (5) Do not tighten the terminal screws too much, otherwise, the screws may break.

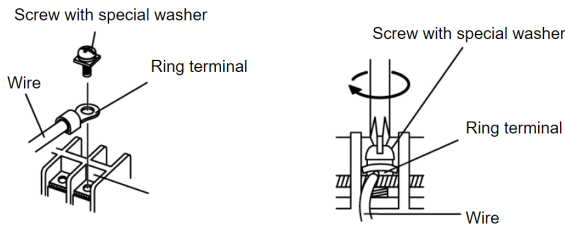

- (6) Refer to the table for the terminal screw tightening torques.

Tightening torque [lbf-in (N·m)]	
M3.5 screw	7.0 to 8.8 (0.8 to 1.0)
M4 screw	10.6 to 15.9 (1.2 to 1.8)
M5 screw	17.7 to 26.5 (2.0 to 3.0)

⚠ CAUTION

- Attach the cable clamp firmly by holding the connection cable, and make sure that the clamp is fixed securely. Incomplete attachment of the cable clamp might cause a malfunction of the open panel.
- Match the terminal block numbers and connection cable colors with those of the outdoor unit or branch box. Erroneous wiring may cause burning of the electric parts.
- Connect the connection cables firmly to the terminal block. Imperfect installation may cause a fire.
- Always fasten the outside covering of the connection cable with the cable clamp. (If the insulator is chafed, electric discharge may occur.)
- Always connect the ground (earth) wire.
- Do not use the ground (earth) screw of the indoor unit for the connection other than a specified outdoor unit.

- (7) Fix the conduit with the supporters as shown below.

Unit: in (mm)

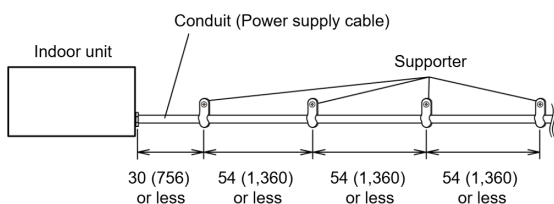

4. OPTIONAL INSTALLATION WORK

4.1. Before install optional wired remote controller

- When you use optional wired remote controller, some functions may not be used.
- Please use the recommended optional wired remote controller.

⚠ CAUTION

- Before installing, be sure to disconnect all power supply.
- Don't touch the heat exchanger.
- During installing or removing operation, be sure not to have wire caught by parts or draw it hard. Or it may result troubles to the air-conditioner.
- Avoid place in direct sunlight.
- Select place that will not be affected by the heat from a stove, etc.
- Before setting up the optional kit, please confirm whether air-conditioner can receive the signal.
- Do not connect the optional wired remote controller to the terminal for power supply.
- When connecting the optional wired remote controller with the indoor unit, please use the connecting cable packaged up with the optional wired remote controller.
- Recommended cable length of optional wired remote controller is 33 ft (10 m). Make sure to do insulate of connecting part when extended the cable.

4.2. External input/output wire modification

- (1) Remove insulation from wire attached to wire kit connector. Remove insulation from locally purchased cable. Use crimp type insulated butt connector to join the cable and wire kit wire.
- (2) Connect the wire and locally purchased wire. (supplied with external connect kit)

Important: Be sure to solder wires to connect. Be sure to insulate the connection between the wires.

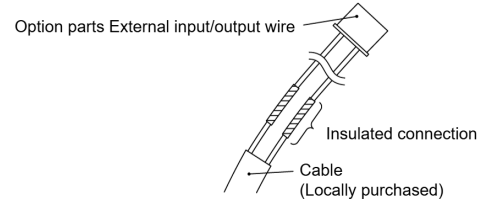

4.3. Side panel L and control cover removal

- (1) Remove the side panel L.
Refer to [3.2. Side panel L, R removal and installation](#).
- (2) Remove the control cover.
(Remove the connection cable from connection number P210 of the circuit board.)
- (3) Remove the control inner cover.

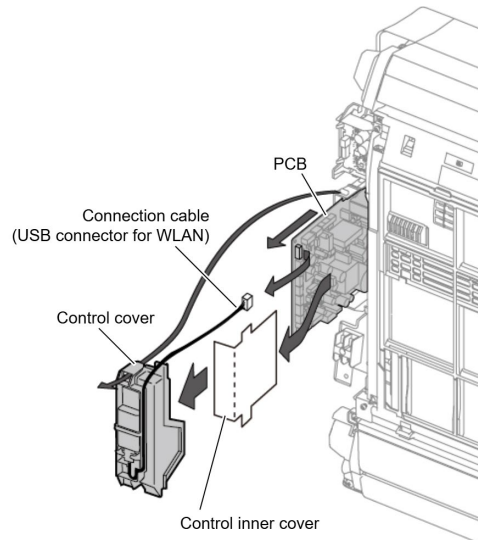

4.4. Connecting cable to control board connector

Connect the cable the circuit board.

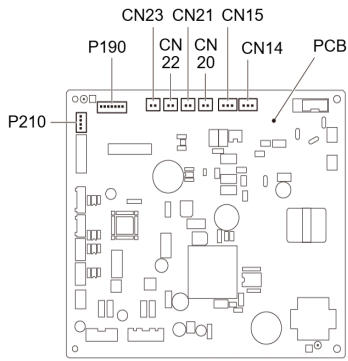

This air conditioner can be connected with the following optional type. For details on how to install optional parts, refer to the installation manual included in each item.

Connector No.	Option type
P190	<ul style="list-style-type: none"> Wired remote controller (via the Communication kit) Simple remote controller (via the Communication kit)
CN14*	External input 1
CN15*	External input 2
CN20*	External output 1
CN21*	External output 2
CN22*	External output 3
CN23*	External output 4
P210	Modbus converter can be connectable. *Cannot be used simultaneously with the WLAN adapter.

*: For external input and external output setting, refer to "5.1. Function details ■ Combination of external input and output".

4.4.1. Wired or Simple remote controller wiring method

The optional parts wiring method for "Wired remote controller" or "Simple remote controller" is as follows.

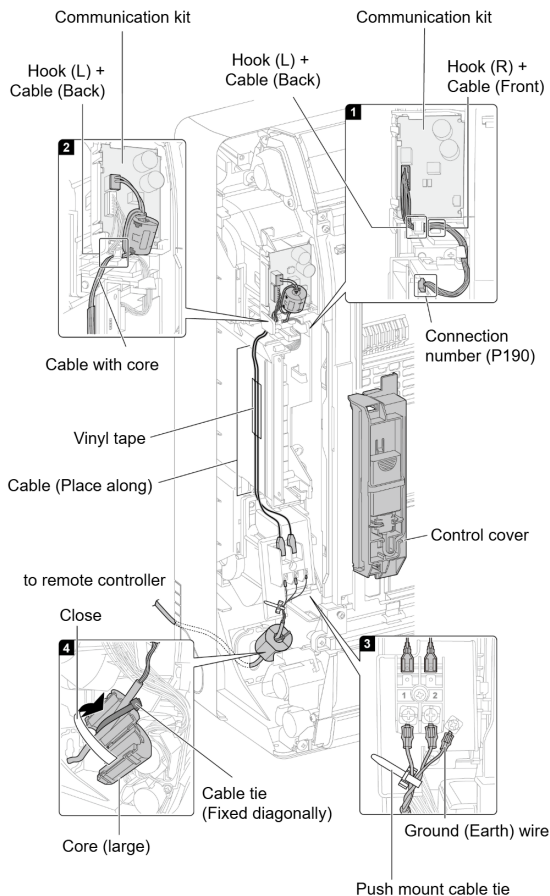

4.4.2. External input and output

External input

- Indoor unit functions such as Operation/Stop or Forced stop can be done by using indoor unit terminals.
- "Operation/Stop" mode or "Forced stop" mode can be selected with function setting of indoor unit.
- A twisted pair cable (22 AWG) should be used. Maximum length of cable is 492 ft. (150 m).
- Use an external input and output cable with appropriate external dimension, depending on the number of cables to be installed.
- The wire connection should be separate from the power cable line.

Dry contact terminal

When a power supply is unnecessary at the input device you want to connect, use the Dry contact terminal.

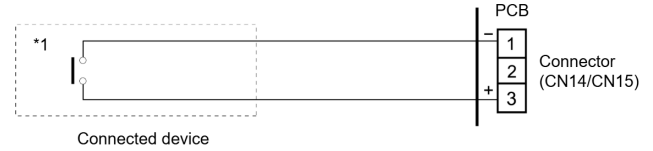

*1: The switch can be used on the following condition: DC 12 V to 24 V, 1 mA to 15 mA.

Operation behavior

Input signal type

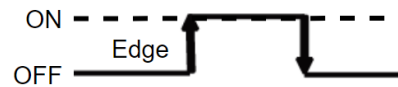

When function setting is "Operation/Stop" mode 1.

Input signal	Command
OFF → ON	Operation
ON → OFF	Stop

When function setting is "Forced stop" mode.

Input signal	Command
OFF → ON	Forced stop
ON → OFF	Normal

When the forced stop is triggered, indoor unit stops and Operation/Stop operation by a remote controller is restricted.

When function setting is "Operation/Stop" mode 2.

Input signal	Command
OFF → ON	Operation
ON → OFF	Stop (R.C. disabled)

NOTE:

- For details, refer to "5.1. Function details ■ Combination of external input and output".

External output

- A twisted pair cable (22AWG) should be used. Maximum length of cable is 82 ft. (25 m).
- Use an external input and output cable with appropriate external dimension, depending on the number of cables to be installed.
- Output voltage: Hi DC12 V±2 V, Lo 0 V.
- Permissible current: 50 mA

Output select

When interlocking with external device

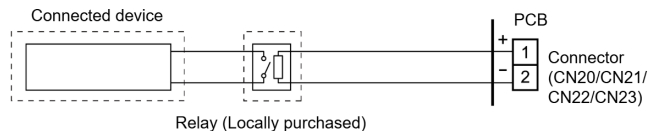

or

When displaying "Operation/Stop"

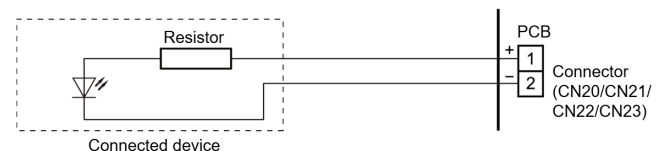

Operation behavior

*If function setting "60" is set to "00", refer to "5. FUNCTION SETTING".

4.5. Side panel L and control cover installation

Install side panel L and control cover by the reverse procedures as stated in [4.3. Side panel L and control cover removal](#).

4.6. Group control

NOTE: Group control cannot be used together with WLAN adapter.

4.6.1. Group control system

A number of indoor units can be operated at the same time using a single remote controller.

*When different types of indoor units (such as wall mounted type and cassette type, cassette type and duct type, or other combinations) are connected using group control system, some functions may no longer be available.

- (1) Connect up to 16 indoor units in a system.

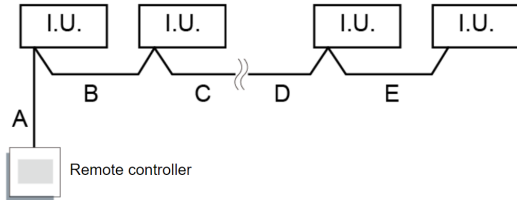

I.U. : Indoor unit
A, B, C, D, E : Remote controller cable.
 $A+B+C+D+E \leq L$

Model	L[yd(m)]
Except UTY-RVRU	546.8 (500)
UTY-RVRU	76.5 (70)

Example of wiring method

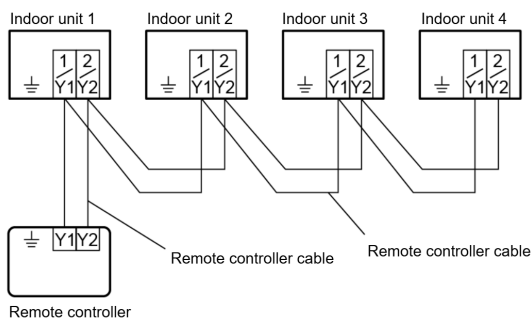

"1 / Y1": 1 or Y1
"2 / Y2": 2 or Y2

- (2) Automatic address setting
- After the remote controller connection in the system, the automatic address setting runs in the initial starting up. Do not change the remote controller address for the indoor unit.

5. FUNCTION SETTING

Perform the Function Setting according to the installation conditions using the remote controller.

CAUTION

- Confirm whether the wiring work for outdoor unit has been finished.
- Confirm that the cover for the electrical enclosure on the outdoor unit is in place.
- This procedure changes to the function settings used to control the indoor unit according to the installation conditions. Incorrect settings can cause the indoor unit to malfunction.
- If the air conditioner is operating, stop the operation. Perform the function setting according to the installation conditions using the remote controller.
- The settings may be selected between the following two: Function number or Setting value.
- Settings will not be changed if invalid numbers or setting values are selected.
- Refer to the installation manual enclosed with the remote controller (option).

5.1. Function details

Filter sign

Select appropriate intervals for displaying the filter sign on the indoor unit according to the estimated amount of dust in the air of the room.

If the indication is not required, select "No indication" (03).

Function number: 11

Setting value	Setting description
00	Standard (400 hours)
01	Long interval (1000 hours)
02	Short interval (200 hours)
03◆	No indication

(◆: Factory setting)

Vertical airflow direction range control

In a concealed installation, change the setting to "Fixed" (02) to restrict the movement of the upper air outlet so that the airflow is only towards the horizontal direction.

Function number: 23

Setting value	Setting description
00◆	Standard
01	(Setting prohibited)
02	Fixed (Concealed)

(◆: Factory setting)

Auto restart

Enable or disable automatic restart after a power interruption.

Function number: 40

Setting value	Setting description
00◆	Enable
01	Disable

(◆: Factory setting)

* Auto restart is an emergency function such as for power outage etc. Do not attempt to use this function in normal operation. Be sure to operate the unit by remote controller or external device.

Room temperature sensor switching

(Only for wired remote controller)

When using the wired remote controller temperature sensor, change the setting to "Both" (01).

Function number: 42

Setting value	Setting description
00◆	Indoor unit
01	Both

(◆: Factory setting)

00: Sensor on the indoor unit is active.

01: Sensors on both indoor unit and wired remote controller are active.

* Remote controller sensor must be turned on by using the remote controller.

Remote controller custom code

(Only for wireless remote controller)

The indoor unit custom code can be changed. Select the appropriate custom code.

Function number: 44

Setting value	Setting description
00◆	A
01	B
02	C
03	D

(◆: Factory setting)

■ Combination of external input and output

By combining the function setting of the indoor unit, you can select various combinations of functions.

Combination examples of external input and output are as follows:

Function number: 46

Setting value	Setting description	
	External input control	
	CN14	CN15
00◆	Operation/Stop mode 1 (R. C. enabled)	Forced thermostat Off
01	(Setting prohibited)	
02	Forced stop mode	Forced thermostat Off
03	Operation/Stop mode 2 (R. C. disabled)	Forced thermostat Off

Function number: 60

Setting value	Setting description					
	External input control		External output control			
	CN14	CN15	CN20	CN21	CN22	CN23
00◆	Follow the setting of 46	Forced thermostat Off	Operation/Stop	Error status	Indoor unit fan operation status	External heater output
01 to 08	Other status (Refer to the Design & technical manual.)					
09	Follow the setting of 46	Forced thermostat Off	Error status	Operation/Stop	Indoor unit fan operation status	External heater output
10	Follow the setting of 46	Forced thermostat Off	Indoor unit fan operation status	Operation/Stop	Error status	External heater output
11	Follow the setting of 46	Forced thermostat Off	External heater output	Operation/Stop	Indoor unit fan operation status	Error status
13 (*1)	Follow the setting of 46	Forced thermostat Off	Alarm	Operation/Stop	Error status	Indoor unit fan operation status
14 (*2)	Ventilation on fan status	Follow the setting of 46	Ventilation	Operation/Stop	Error status	Indoor unit fan operation status
15 (*2)	Ventilation on fan status	Follow the setting of 46	Ventilation	Alarm	Error status	Indoor unit fan operation status

(◆: Factory setting)

*1: This function operates only when Function 81 is set to "02" or "04"

*2: This function operates only when Function 81 is set to "04"

■ Room temperature sensor switching (Aux.)

To use the temperature sensor on the wired remote controller only, change the setting to "Wired remote controller" (01).

This function will only work if the function setting 42 is set at "Both" (01).

Function number: 48

Setting value	Setting description
00◆	Both
01	Wired remote controller

(◆: Factory setting)

■ Indoor unit fan control for energy saving for cooling

Enables or disables the power-saving function by controlling the indoor unit fan rotation when the outdoor unit is stopped during cooling operation.

Function number: 49

Setting value	Setting description
00	Disable
01	Enable
02◆	Remote controller

(◆: Factory setting)

00: When the outdoor unit is stopped, the indoor unit fan operates continuously following the setting on the remote controller.

01: When the outdoor unit is stopped, the indoor unit fan operates intermittently at a very low speed.

02: Enable or disable this function by remote controller setting.

*When using a wired remote controller without Indoor unit fan control for energy saving for cooling function, or when connecting the Network converter, the setting cannot be made by using the remote controller. Set to (00) or (01). To confirm if the remote controller has this function, refer to the operation manual of each remote controller.

■ Control switching of external heaters

Sets the control method for the external heater being used. For details of the control method, refer to the Design & Technical Manual.

Function number: 61

Setting value	Setting description
00◆	Auxiliary heater control 1
01	Auxiliary heater control 2
02	Heat pump prohibition control
03	Heater selection control using outdoor temperature 1
04	Heater selection control using outdoor temperature 2
05	Heater selection control using outdoor temperature 3
06	Auxiliary heat pump control
07	Auxiliary heat pump control by outdoor temperature 1
08	Auxiliary heat pump control by outdoor temperature 2
09	Auxiliary heat pump control by outdoor temperature 3

(◆: Factory setting)

■ Standby time for auxiliary equipment operation

Sets the standby time until the auxiliary equipment operation starts during primary equipment operation.

Function number: 71

Setting value	Setting description
00◆	Disable
01	1 minutes
02 to 98	2 minutes to 98 minutes
99	99 minutes

(◆: Factory setting)

■ Heat pump backup setting

Enables or disables the heat pump backup instruction from the outdoor unit.

This function will be usable provided that the corresponding outdoor unit is connected.

Function number: 72

Setting value	Setting description
00◆	Disable
01	Enable

(◆: Factory setting)

■ Emergency heat for external output terminal

Enables or disables emergency heat input.

To use this function, select "External heater output" after entering function number 60. For more information, refer to the Design & technical manual.

Function number: 73

Setting value	Setting description
00◆	Disable
01	Enable

(◆: Factory setting)

■ Safety measures setting for refrigerant leakage

Sets the safety measures operation in case of refrigerant leakage.

Function number: 81

Setting value	Setting description
00◆	No safety measure
01	Air circulation
02	Air circulation, Alarm
03	(Setting prohibited)
04	Air circulation, Alarm, Mechanical ventilation

(◆: Factory setting)

- To activate the safety measures operation for the indoor unit in case of refrigerant leakage, set the setting value to "01", "02" or "04" (Air circulation).
- When the indoor unit detects refrigerant leakage or the refrigerant leakage sensor failure, the indoor unit operates as follows.
 - The indoor unit operates the fan at high speed to diff use the refrigerant, according to UL60335-2-40.

NOTE:

- Remote controller cannot stop this fan operation for safety reasons.
 - The indoor unit stops cooling or heating operation. Also, Forced cooling operation is not allowed.
 - The indoor unit or wired remote controller (option) indicates error code 45 or A8.

■ Wired remote controller function extension setting

Enables the "Powerful", "Minimum heat", or "Outdoor Unit Low Noise" operation when connecting the Wired Remote Controller (UTY-RVRU).

Function number: 84

Setting value	Setting description
00◆	Disable
01	Enable

(◆: Factory setting)

- Refer to the operation manual of the air conditioner to check whether it supports each function.
- All indoor units must have the same setting value in a Group Control system.

■ Setting record

Record any changes to the settings in the following table.

Function number	Setting description	Setting value
11	Filter sign	
23	Vertical airflow direction range control	
40	Auto restart	
42	Room temperature sensor switching	
44	Remote controller custom code	
46	External input control	
48	Room temperature sensor switching (Aux.)	
49	Indoor unit fan control for energy saving for cooling	
60	External output control	
61	Control switching of external heaters	
71	Standby time for auxiliary equipment operation	
72	Heat pump backup setting	
73	Emergency heat for external output terminal	
81	Safety measures setting for refrigerant leakage	
84	Wired remote controller function extension setting	

After completing the function setting, be sure to disconnect the power supply and then re-connect it.

5.2. Temperature correction

NOTE:

- When changing Function 95, perform this setting before other Room temp. control settings (Function 30, 31, 35, 36).

If Function 95 is not set first, Room temperature control settings (Function 30, 31, 35, 36) will be reset and you must re-do them again.

■ Heat Insulation condition (building insulation)

Heat insulation conditions differ according to the installed environment.

"Standard insulation" (00) allows system to rapidly respond to the cooling or heating load changes.

"High insulation" (01) is when the heat insulation structure of the building is high and does not require system to rapidly respond to cooling or heating load changes.

When "High insulation" (01) is selected;

- Overheating (overcooling) is prevented at the start-up.
- All room temp. control settings (Function 30, 31, 35, 36) will reset to "No correction" [0.0°F (0.0°C)].

Function number: 95

Setting value	Setting description
00◆	Standard insulation
01	High insulation

(◆: Factory setting)

■ Room temperature control for indoor unit sensor

Depending on the installed environment, correction of the room temperature sensor may be required.

Select the appropriate control setting according to the installed environment.

The temperature of the room temperature sensor is corrected as follows:

Corrected temp. = Temp. of room temp. sensor – correction temp. value

Example of correction:

When the temperature of room temp. sensor is 79 °F (26 °C) and the setting value is "03" [-2 °F (-1.0 °C)], the corrected temp. will be 81 °F [79 °F - (-2 °F)] (27 °C [26 °C - (-1.0 °C)]).

The temperature correction values show the difference from the "Standard setting" (00) (manufacturer's recommended value).

Function number: 30 (For cooling) / 31 (For heating)

Setting value	Setting description
00◆	Standard setting
01	No correction 0 °F (0.0 °C)
02	-1 °F (-0.5 °C)
03	-2 °F (-1.0 °C)
04	-3 °F (-1.5 °C)
05	-4 °F (-2.0 °C)
06	-5 °F (-2.5 °C)
07	-6 °F (-3.0 °C)
08	-7 °F (-3.5 °C)
09	-8 °F (-4.0 °C)
10	+1 °F (+0.5 °C)
11	+2 °F (+1.0 °C)
12	+3 °F (+1.5 °C)
13	+4 °F (+2.0 °C)
14	+5 °F (+2.5 °C)
15	+6 °F (+3.0 °C)
16	+7 °F (+3.5 °C)
17	+8 °F (+4.0 °C)

(◆: Factory setting)

Setting value 02-09: More Cooling Less Heating

Setting value 10-17: Less Cooling More Heating

■ Room temperature control for wired remote controller sensor

Depending on the installed environment, correction of the wired remote temperature sensor may be required.

Select the appropriate control setting according to the installed environment.

To change this setting, set Function 42 to "Both" (01).

Ensure that the Thermo Sensor icon is displayed on the remote controller screen.

Function number: 35 (For cooling) / 36 (For heating)

Setting value	Setting description
00◆	No correction
01	No correction 0 °F (0.0 °C)
02	-1 °F (-0.5 °C)
03	-2 °F (-1.0 °C)
04	-3 °F (-1.5 °C)
05	-4 °F (-2.0 °C)
06	-5 °F (-2.5 °C)
07	-6 °F (-3.0 °C)
08	-7 °F (-3.5 °C)
09	-8 °F (-4.0 °C)
10	+1 °F (+0.5 °C)
11	+2 °F (+1.0 °C)
12	+3 °F (+1.5 °C)
13	+4 °F (+2.0 °C)
14	+5 °F (+2.5 °C)
15	+6 °F (+3.0 °C)
16	+7 °F (+3.5 °C)
17	+8 °F (+4.0 °C)

(◆: Factory setting)

Setting value 02-09: More Cooling Less Heating

Setting value 10-17: Less Cooling More Heating

■ **Setting record**

Record any changes to the settings in the following table.

Function number	Setting description	Setting value
95	Heat Insulation condition (building insulation)	
30	Room temperature control for indoor unit sensor (Cooling)	
31	Room temperature control for indoor unit sensor (Heating)	
35	Room temperature control for wired remote controller sensor (Cooling)	
36	Room temperature control for wired remote controller sensor (Heating)	

After completing the function setting, be sure to disconnect the power supply and then reconnect it.

6. TEST RUN

⚠ WARNING

Do not turn on the power until all installation work is complete.

⚠ CAUTION

When restarting after a long period of disuse in the winter, turn the power switch on at least 12 hours before starting the unit.

■ **Check items**

- (1) Is operation of each button on the remote controller normal?
- (2) Does each lamp light normally?
- (3) Do airflow direction louvers operate normally?
- (4) Is the drain normal?
- (5) Do not have an abnormal noise and vibration during operation?

Do not operate the air conditioner in test run for a long time.

NOTES:

- After test run, a buzzer beeps.
- If the indoor unit fan rotates and the ECONOMY lamp blinks, refrigerant leakage may have occurred.
- Open the windows to ventilate the room and contact an authorized service personnel.

■ **Operation method**

Depending on your installation, choose from the following:

● **By the wireless remote controller (with [TEST RUN])**

- (1) To start test run, press [START/STOP] and [TEST RUN] on the remote controller.
- (2) To end test run, press [START/STOP] on the remote controller.

● **By the indoor unit**

- (1) To start test run, press [MANUAL AUTO] of the unit for more than 10 seconds (forced cooling).
- (2) To end test run, press [MANUAL AUTO] for more than 3 seconds or press [START/STOP] on the remote controller.

● **By the wired remote controller**

- (1) For the operation method, refer to the installation manual and the operating manual of the wired remote controller.

When the air conditioner is running the test run, the "OPERATION" Lamp and "TIMER" Lamp will simultaneously flash slowly.

Heating test run will begin in a few minutes when HEAT is selected by the remote controller [reverse cycle model only].

7. FINISHING

- (1) Insulate between pipes.
 - Overlap the connection pipe heat insulation and indoor unit pipe heat insulation.
 - Wrapping the connection pipe with cloth tape over the range within which they fit into the rear piping housing section.
 - Fasten the pipe bracket with the screw.
- (2) Fill the gap between the outside wall pipe hole and the pipe with sealer so that rain water and wind cannot blow in.
- (3) Fasten the drain hose to the outside wall, etc.

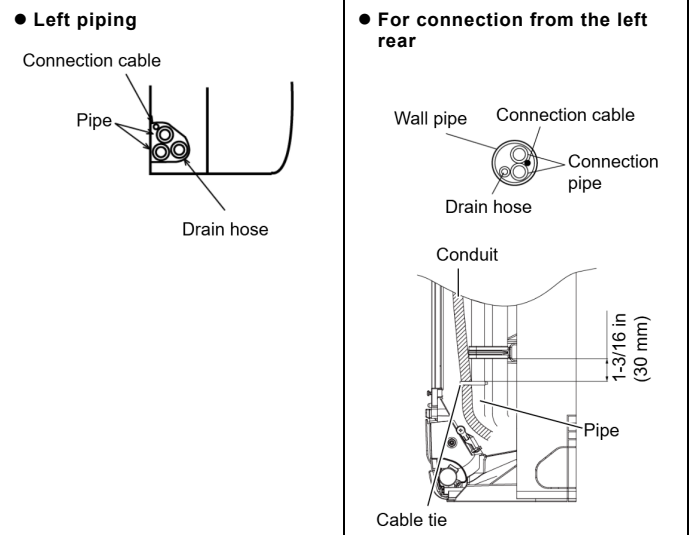
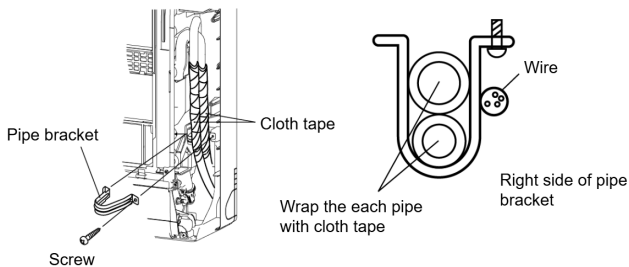

● **Check the following:**

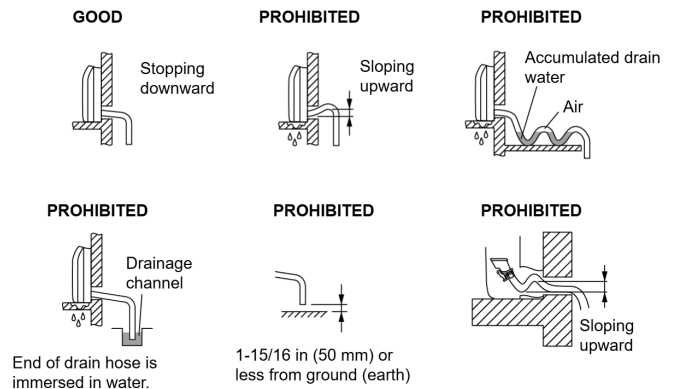

8. CUSTOMER GUIDANCE

Explain the following to the customer in accordance with the operation manual:

- (1) Starting and stopping method, operation switching, temperature adjustment, timer, airflow switching, and other remote control unit operations.
- (2) Air filter removal and cleaning, and how to use the air louvers.
- (3) Give the operation manual to the customer.

9. ERROR CODES

If you use a wireless remote controller, the lamp on the photo detector unit will output error codes by way of blinking patterns.

If you use a wired remote controller, error codes will appear on the remote control display. Refer to the lamp blinking patterns and error codes in the table. An error display is displayed only during operation.

The error code table contains errors irrelevant to this product as well.

■ **Error display on the indoor unit**

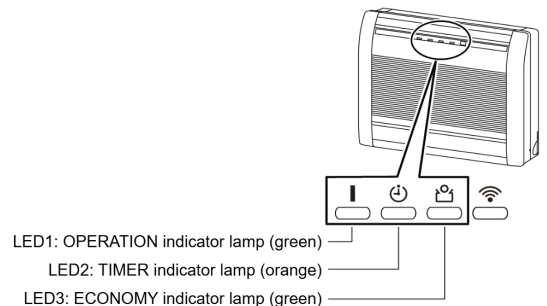

If error code 24 is indicated.



- [LED1]: 2 times
- [LED2]: 4 times
- [LED3]: Always blinking

The first and second digits of the error code are indicated by the number of times the lamp blinks.

[Blinking interval]

- LED1,2 : 0.5s ON / 0.5s OFF
- LED3 : 0.1s ON / 0.1s OFF (Always blinking)

*The alphabet is indicated by the following number of times the lamp blinks.
A:10 times C:11 times J:13 times U:15 times

Error code	Description
11	Serial communication error
12	Wired remote controller communication error
15	Check run unfinished Automatic airflow adjustment error
16	Peripheral unit transmission PCB connection error
18	External communication error
21	Unit number or Refrigerant circuit address setting error [simultaneous multi-split type]
22	Indoor unit capacity error
23	Combination error
24	<ul style="list-style-type: none"> • Connection unit number error (indoor secondary unit) [simultaneous multi-split type] • Connection unit number error (indoor unit or branch unit) [flexible multi-split type]
26	Indoor unit address setting error
27	Primary unit, secondary unit setup error [simultaneous multi-split type]
29	Connection unit number error in wired remote controller system
31	Power supply interruption error
32	Indoor unit PCB model information error
33	Indoor unit motor electricity consumption detection error
35	Manual auto switch error
39	Indoor unit power supply error for fan motor
3A	Indoor unit communication circuit (wired remote controller) error
41	Room temp. sensor error
42	Indoor unit heat ex. middle temp. sensor error
44	Occupancy sensor error
45	Refrigerant leakage sensor error
51	Indoor unit fan motor error
53	Drain pump error
54	Electric air cleaner reverse VDD error
55	Filter set error
57	Damper error
58	Intake grille error
59	Indoor unit fan motor 2 error (Lower fan)
5A	Indoor unit fan motor 3 error (Right side fan)
5U	Indoor unit error
61	Outdoor unit reverse/missing phase and wiring error
62	Outdoor unit main PCB model information error or communication error
63	Inverter error
64	Active filter error, PFC circuit error
65	<ul style="list-style-type: none"> • Trip terminal L error • IPM temp error
68	Outdoor unit rush current limiting resistor temp. rise error
6A	Display PCB microcomputers communication error
71	Discharge temp. sensor error
72	Compressor temp. sensor error
73	Outdoor unit Heat Ex. liquid temp. sensor error
74	Outdoor temp. sensor error
75	Suction Gas temp. sensor error
76	<ul style="list-style-type: none"> • 2-way valve temp. sensor error • 3-way valve temp. sensor error
77	Heat sink temp. sensor error
82	<ul style="list-style-type: none"> • Sub-cool Heat Ex. gas inlet temp. sensor error • Sub-cool Heat Ex. gas outlet temp. sensor error
83	Liquid pipe temp. sensor error
84	Current sensor error
86	<ul style="list-style-type: none"> • Discharge pressure sensor error • Suction pressure sensor error • High pressure switch error
94	Trip detection
95	Compressor rotor position detection error (permanent stop)
97	Outdoor unit fan motor 1 error
98	Outdoor unit fan motor 2 error
99	4-way valve error
9A	Coil (expansion valve) error
A1	Discharge temp. error
A3	Compressor temp. error
A4	High pressure error
A5	Low pressure error
A8	Refrigerant leak detection
AC	Heat sink temp error
J2	Branch boxes error [flexible multi-split type]
J7	External device error

■ Error code on the wired remote controller (option)

Check the error

- (1) If an error occurs, an error icon appears on the "Monitor mode screen".
Touch the [Status] on the "Monitor mode screen". The "Status" screen is displayed.
- (2) Touch the [Error Information] on the "Status" screen. The "Error Information" screen is displayed. (If there are no errors, the [Error Information] will not be displayed.)
- (3) 2-digit numbers correspond to the error code in the table. Touch the [Next page] (or [Previous page]) to switch to other connected indoor units.

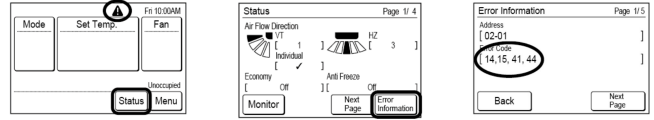

■ How to check the error memory

When an error occurs, the operation lamp (Green) and the timer lamp (Orange) indicate the error content by blinking. To check the error memory, follow the procedures below.

- (1) Stop the operation of the air conditioner, and then disconnect the power supply.
- (2) Reconnect the power supply.
- (3) In one of the following two methods, the memorized error is only displayed during the "3 minutes ST"* state period.
 - Start the operation and then press [TEST RUN] on the wireless remote controller (option).
 - or
 - Press hold [MANUAL AUTO] on the indoor unit for 10 seconds or more.

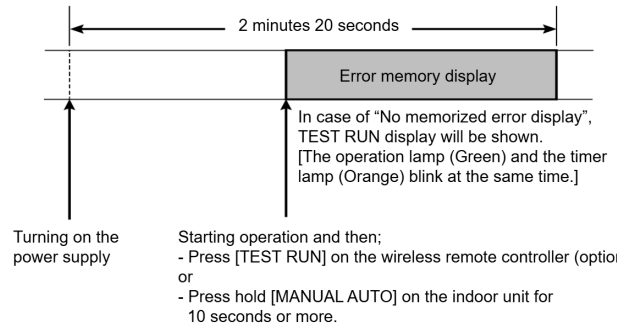

*: The "3 minutes ST" period lasts 2 minutes and 20 seconds after turning on the power supply.

■ How to erase the error memory

Manual erase: Pressing [MANUAL AUTO] on the indoor unit while the "Error memory display" is being shown. (Short beep emits for about 3 seconds.)

10. REFRIGERANT LEAK DETECTION FUNCTION

■ System operation after refrigerant leak detection:

- Indoor unit starts diffusion operation by high fan speed.
- Due to safety reasons, a remote controller cannot stop this operation.
- Indoor unit indicates Error code A8 (OPERATION lamp [10], TIMER lamp [8]).
[]: Number of flashing
- Indoor unit makes a warning beep. (Only when Function 81 is set to "02" or "04".)
The beep stops by pressing [START/STOP] of the remote controller or [MANUAL AUTO] on the indoor unit.
- System stops the cooling/heating operation. Forced cooling operation is not available.