



Installation and Operation Manual

Condensing Units

5TTX5018 – 060

ALL phases of this installation must comply with NATIONAL, STATE AND LOCAL CODES

IMPORTANT – This Document is customer property and is to remain with this unit. Please return to service information pack upon completion of work.

These instructions do not cover all variations in systems or provide for every possible contingency to be met in connection with the installation. Should further information be desired or should particular problems arise which are not covered sufficiently for the purchaser's purposes, the matter should be referred to your installing dealer or local distributor.

Note: The manufacturer recommends installing only approved matched indoor and outdoor systems. Some of the benefits of installing approved matched indoor and outdoor split systems are maximum efficiency, optimum performance and the best overall system reliability.

Note: R-454B refrigerant is an "A2L" refrigerant meaning: A = non-toxic, 2 = flammable, L = low burning velocity. The term "A2L" is used throughout this document.

Table of Contents

Section 1. Safety.....	2
Section 2. Unit Location Considerations.....	3
Section 3. Unit Preparation.....	4
Section 4. Setting the Unit.....	4
Section 5. Refrigerant Line Considerations.....	4
Section 6. Refrigerant Line Routing.....	5
Section 7. Refrigerant Line Brazing.....	7
Section 8. Refrigerant Line Leak Check.....	8
Section 9. Evacuation.....	8
Section 10. Service Valves.....	8
Section 11. Electrical – Low Voltage.....	9
Section 12. Electrical – High Voltage.....	11
Section 13. Start Up.....	11
Section 14. System Charge Adjustment.....	12
Section 15. Checkout Procedures.....	16
Section 16. Refrigeration Circuits.....	18
Section 17. Wiring Diagrams.....	20
Section 18. Pressure Curves.....	23

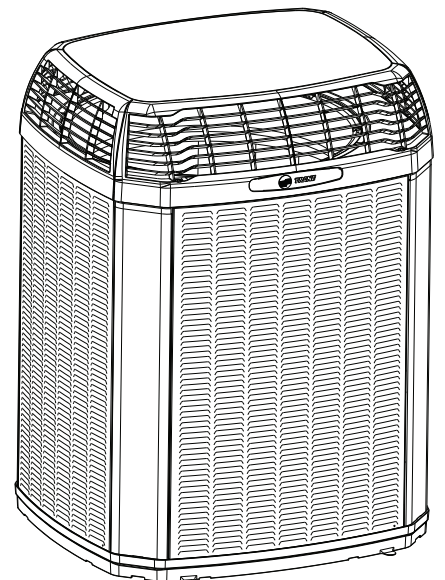

Section 1. Safety

WARNING

Only qualified personnel should install and service the equipment. The installation, starting up, and servicing of heating, ventilating, and air-conditioning equipment can be hazardous and requires specific knowledge and training. Improperly installed, adjusted or altered equipment by an unqualified person could result in death or serious injury. When working on the equipment, observe all precautions in the literature and on the tags, stickers, and labels that are attached to the equipment.

WARNING

RISK OF FIRE!

Flammable refrigerant used. To be repaired only by trained service personnel. Do not puncture refrigerant tubing.

Dispose of properly in accordance with federal or local regulations. Flammable refrigerant used.

WARNING

This information is intended for use by individuals possessing adequate backgrounds of electrical and mechanical experience. Any attempt to repair a central air conditioning product may result in personal injury and/or property damage. The manufacture or seller cannot be responsible for the interpretation of this information, nor can it assume any liability in connection with its use.

WARNING

UNIT CONTAINS R-454B REFRIGERANT!
Proper service equipment is required. Failure to use proper service tools may result in equipment damage or personal injury.

SERVICE

USE ONLY R-454B REFRIGERANT AND APPROVED COMPRESSOR OIL.

WARNING

Extreme caution should be exercised when opening the Liquid Line Service Valve. Turn counterclockwise until the valve stem just touches the rolled edge. No torque is required. Failure to follow this warning will result in abrupt release of system charge and may result in personal injury and /or property damage.

WARNING

Ensure that the area is in the open or that it is adequately ventilated before breaking into the system or conducting any hot work.

WARNING

The appliance shall be stored in a room without continuously operating ignition sources (for examples: open flames, an operating gas appliance or an operating electric heater). Do not pierce or burn. Be aware that refrigerants may not contain an odour.

WARNING

LIVE ELECTRICAL COMPONENTS!

During installation, testing, servicing, and troubleshooting of this product power should be disconnected. It may be necessary to work with live electrical components. Failure to follow all electrical safety precautions when exposed to live electrical components could result in death or serious injury.

WARNING

The appliance is not to be used by persons (including children) with reduced physical, sensory or mental capabilities, or lack of experience and knowledge, unless they have been given supervision or instruction.

WARNING

Children should be supervised to ensure that they do not play with the appliance.

CAUTION

If using existing refrigerant lines should be brazed not soldered. Solder alloys with a melting temperature less than 427°C are not acceptable.

CAUTION

Scroll compressor dome temperatures may be hot. Do not touch the top of compressor; it may cause minor to severe burning.

WARNING

WARNING!

This product can expose you to chemicals including lead, which are known to the State of California to cause cancer and birth defects or other reproductive harm. For more information go to www.P65Warnings.ca.gov

Table 1. Operating Range

Mode	Model	Operating Range
Cooling	1.5 – 5 Ton	55°F – 120°F

Section 2. Unit Location Considerations

2.1 Unit Dimensions and Weight

Table 2.1

Unit Dimensions and Weight		
Models	H x D x W (in)	Weight* (lb)
5TTX5018A	42 x 30 x 33	193
5TTX5024A	38 x 30 x 33	165
5TTX5030A	42 x 30 x 33	195
5TTX5036A	38 x 30 x 33	165
5TTX5042A	44 x 34 x 37	221
5TTX5048A	52 x 34 x 37	261
5TTX5060A	52 x 34 x 37	261

* Weight values are estimated.

When mounting the outdoor unit on a roof, be sure the roof will support the unit's weight.

Properly selected isolation is recommended to alleviate sound or vibration transmission to the building structure.

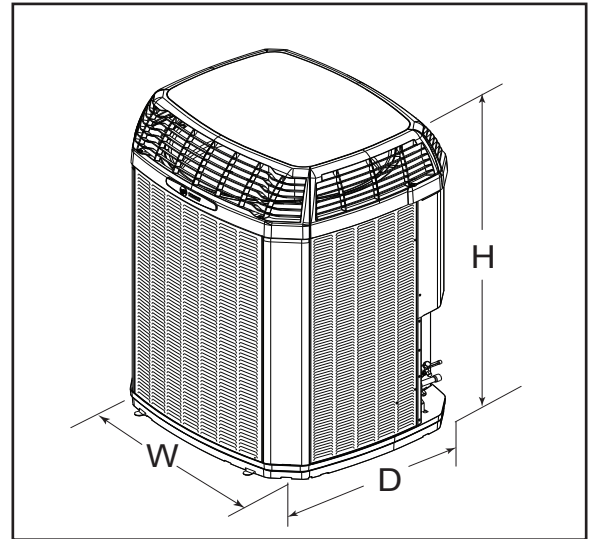

2.2 Refrigerant Piping Limits

1. The maximum TOTAL length of refrigerant lines from outdoor to indoor unit should NOT exceed 150 feet (including lift).
2. The maximum vertical change should not exceed 50 feet.
3. Service valve connection diameters are shown in Table 5.1.

Note: For other line lengths, refer to Refrigerant Piping Application Guide, SS-APG006-EN or Refrigerant Piping Software Program, 32-3312-03 (or latest revision).

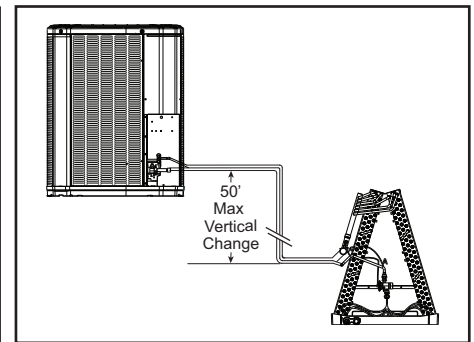
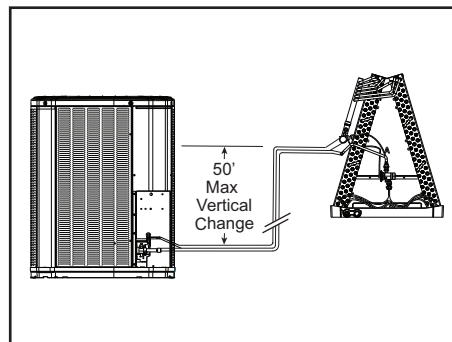
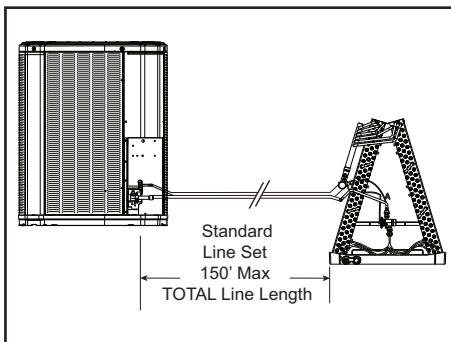

2.3 Suggested Locations for Best Reliability

Ensure the top discharge area is unrestricted for at least five (5) feet above the unit.

Three (3) feet clearance must be provided in front of the control box (access panels) and any other side requiring service.

Do not locate close to bedrooms as operational sounds may be objectionable.

Position the outdoor unit a minimum of 12" from any wall or surrounding shrubbery to ensure adequate airflow.

Outdoor unit location must be far enough away from any structure to prevent excess roof runoff water from pouring directly on the unit.

Please reference Indoor Unit Installer's Guide for correct specifications on indoor unit install.

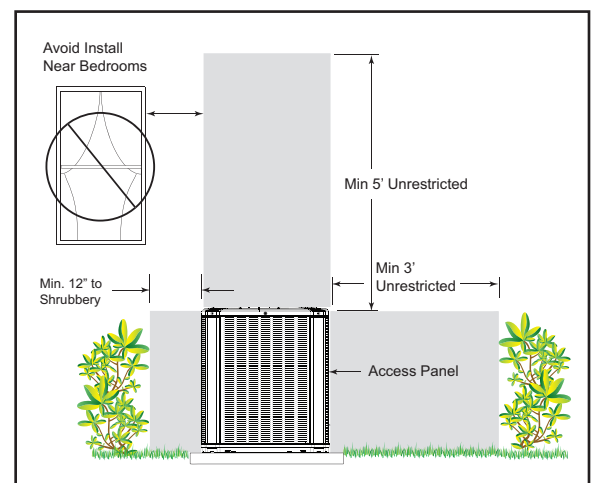

2.4 Coastal Considerations

If installed within one mile of salt water, including seacoasts and inland waterways, models without factory supplied Seacoast Salt Shields require the addition of BAYSEAC001 (Seacoast Kit) at installation time.

Section 3. Unit Preparation

3.1 Prepare The Unit For Installation

STEP 1 - Check for damage and report promptly to the carrier any damage found to the unit.

STEP 2 - To remove the unit from the pallet, remove tabs by cutting with a sharp tool.

Section 4. Setting the Unit

4.1 Pad Installation

When installing the unit on a support pad, such as a concrete slab, consider the following:

- The pad should be at least 1" larger than the unit on all sides.
- The pad must be separate from any structure.
- The pad must be level.
- The pad should be high enough above grade to allow for drainage.
- The pad location must comply with National, State, and Local codes.

Section 5. Refrigerant Line Considerations

5.1 Refrigerant Line and Service Valve Connection Sizes

Table 5.1

Model	Rated Line Sizes		Alternate Line Sizes	Service Valve Connection Sizes	
	Vapor Line	Liquid Line	Liquid Line	Vapor Line Connection	Liquid Line Connection
5TTX5018A	3/4	5/16	3/8	3/4	5/16
5TTX5024A	3/4	5/16	3/8	3/4	5/16
5TTX5030A	3/4	5/16	3/8	3/4	5/16
5TTX5036A	3/4	5/16	3/8	3/4	5/16
5TTX5042A	3/4	5/16	3/8	3/4	5/16
5TTX5048A	7/8	5/16	3/8	7/8	5/16
5TTX5060A	1-1/8	5/16	3/8	7/8	5/16

5.2 Factory Charge

The outdoor condensing units are factory charged with the system charge required for the outdoor condensing unit, ten (10) feet of tested connecting line, and the smallest rated indoor evaporative coil match. Always verify proper system charge via subcooling (TXV/EEV) or superheat (fixed orifice) per the unit nameplate.

5.3 Required Refrigerant Line Length

Determine required line length and lift. You will need this later in STEP 2 of Section 14.

Total Line Length = _____ Ft.

Total Vertical Change (lift) = _____ Ft.

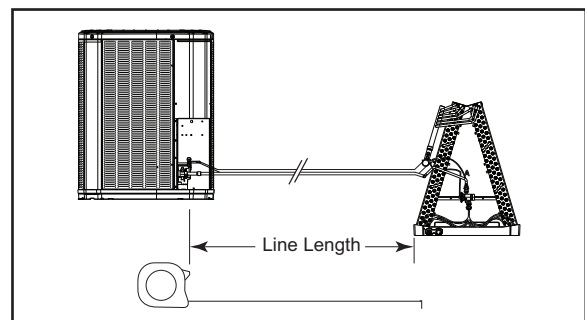

5.4 Refrigerant Line Insulation

Important: The Vapor Line must always be insulated. DO NOT allow the Liquid Line and Vapor Line to come in direct (metal to metal) contact.

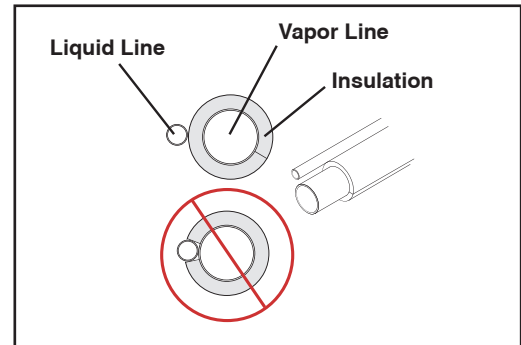

5.5 Reuse Existing Refrigerant Lines

⚠ CAUTION

REFRIGERANT!

Failure to inspect or use proper service tools may result in equipment damage or personal injury. If using existing refrigerant lines make certain that all joints are brazed, not soldered.

For retrofit applications, where the existing indoor evaporator coil and/or refrigerant lines will be used, the following precautions should be taken:

- Ensure that the indoor evaporator coil and refrigerant lines are the correct size.
- Ensure that the refrigerant lines are free of leaks, acid, and oil.

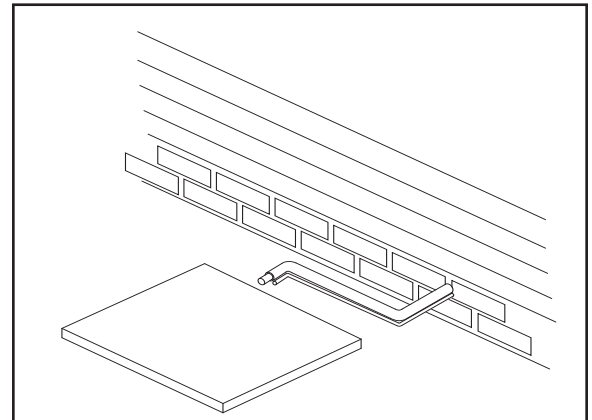

Section 6. Refrigerant Line Routing

6.1 Precautions

Important: Comply with National, State, and Local Codes when isolating line sets from joists, rafters, walls, or other structural elements.

Important: For buried linesets, see publication number SS-APG006-EN.

Important: Take precautions to prevent noise within the building structure due to vibration transmission from the refrigerant lines.

Important: Take care that piping material, pipe routing, and installation shall include protection from physical damage in operation and service, and be in compliance with national and local codes and standards, such as ASHRAE 15, ASHRAE 15.2, IAPMO Uniform Mechanical Code, ICC International Mechanical Code, or CSA B52. All field joints shall be accessible for inspection prior to being covered or enclosed.

Important: Take care to account for expansion and contraction of long runs of piping.

For Example:

- When the refrigerant lines must be fastened to floor joists or other framing in a structure, use isolation type hangers.
- Isolation hangers should also be used when refrigerant lines are run in stud spaces or enclosed ceilings.
- Where the refrigerant lines run through a wall or sill, they should be insulated, isolated and servicable.
- Isolate the lines from all duct work.
- Minimize the number of 90° turns.

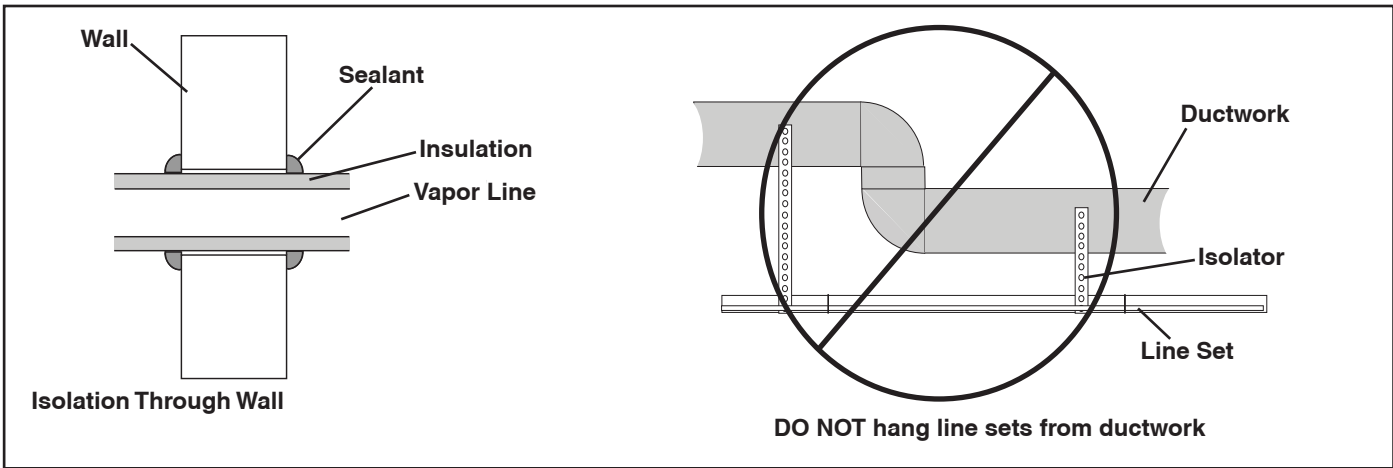
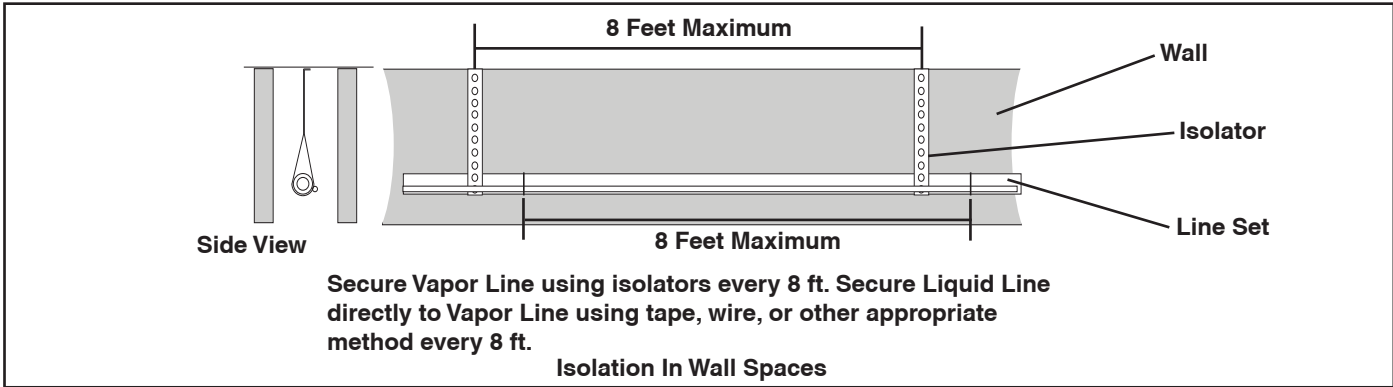
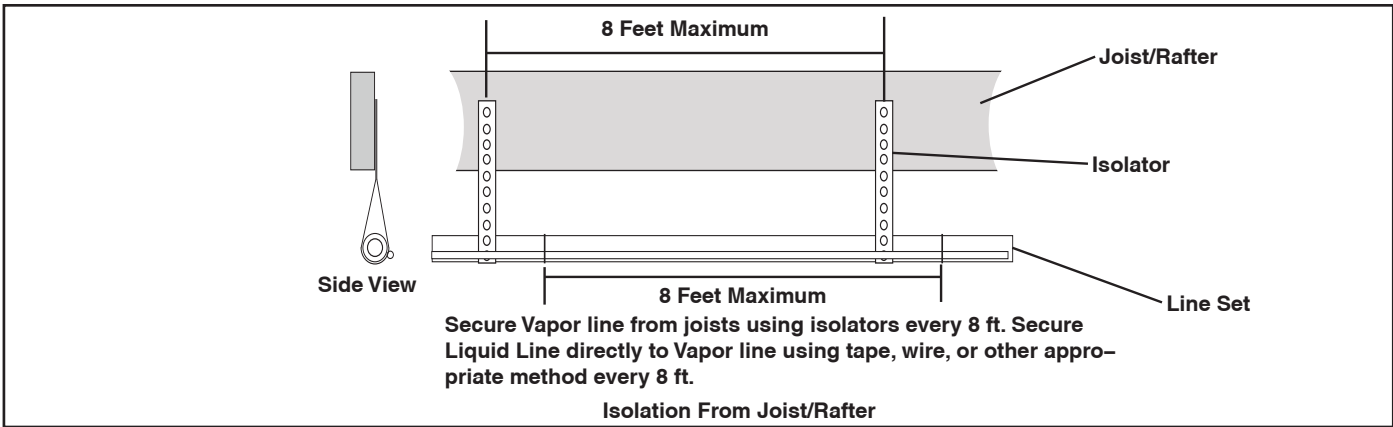

Section 7. Refrigerant Line Brazing

7.1 Braze The Refrigerant Lines

STEP 1 - Remove caps or plugs. Use a deburring tool to deburr the pipe ends. Clean both internal and external surfaces of the tubing using an emery cloth.

STEP 2 - Remove the pressure tap cap and valve cores from both service valves.

STEP 3 - Purge the refrigerant lines and indoor coil with dry nitrogen.

Purge the refrigerant lines and indoor coil with dry nitrogen.

Note: A2L equipment shall have red marked service ports and pipes through which refrigerant is serviced.

STEP 4 - Wrap a wet rag around the valve body to avoid heat damage and continue the dry nitrogen purge. Braze the refrigerant lines to the service valves.

For units shipped with a field-installed external drier, check liquid line filter drier's directional flow arrow to confirm correct direction of refrigeration flow (away from outdoor unit and toward evaporator coil) as illustrated. Braze the filter drier to the Liquid Line.

Continue the dry nitrogen purge. Do not remove the wet rag until all brazing is completed.

Important: Remove the wet rag before stopping the dry nitrogen purge.

Note: Install drier in Liquid Line.

NOTE: Precautions should be taken to avoid heat damage to basepan during brazing. It is recommended to keep the flame directly off of the basepan.

STEP 5 - Replace the pressure tap valve cores and plastic tabs after the service valves have cooled.

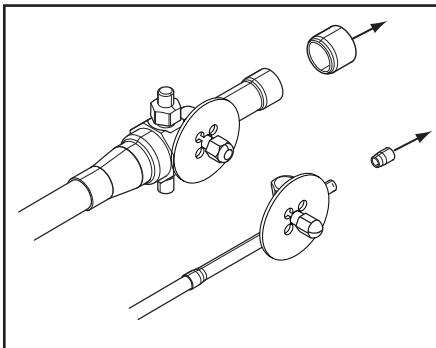

STEP 1

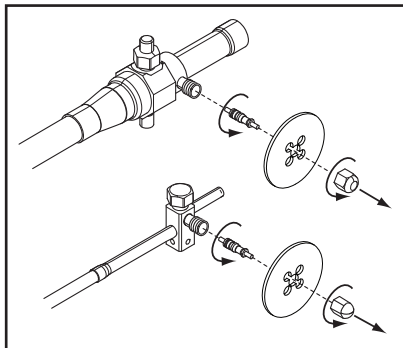

STEP 2

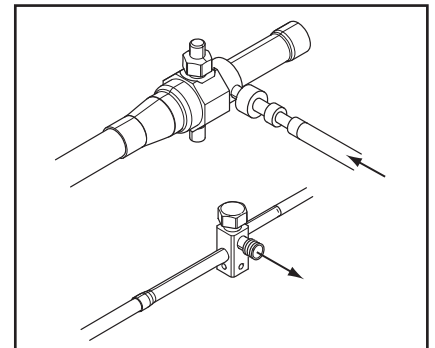

STEP 3

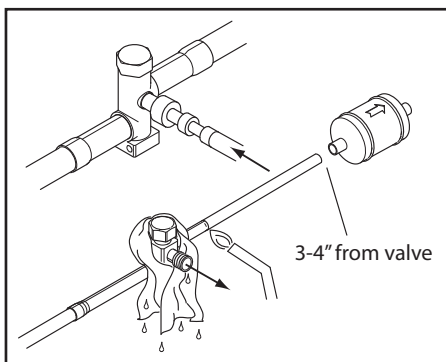

STEP 4

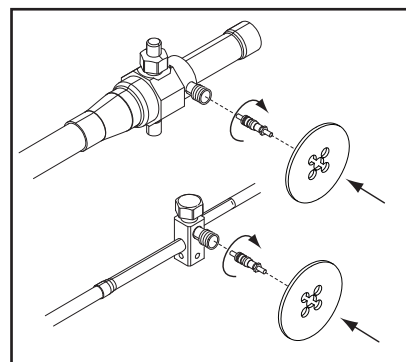

STEP 5

Section 8. Refrigerant Line Leak Check

8.1 Check For Leaks

After completion of field piping for split systems, the field pipework shall be pressure tested with nitrogen and then vacuum tested prior to refrigerant charging, according to the following requirements:

1. The minimum leak test pressure of the lineset and indoor coil shall be the high side design pressure, unless the high side of the system, cannot be isolated from the low side of the system in which case the entire system shall be pressure tested to the low side design pressure.
2. The test pressure after removal of pressure source shall be maintained for at least 1 hour with no decrease of pressure indicated by the test gauge, with test gauge resolution not exceeding 5% of the test pressure.

Important: Under no circumstances shall potential sources of ignition be used in the searching for or detection of refrigerant leaks.

Important: The following leak detection methods are deemed acceptable for all refrigerant systems:

- Electronic leak detectors calibrated for R454B
- Bubble method

STEP 1 - Pressurize the refrigerant lines and evaporator coil to 150 PSIG using dry nitrogen.

STEP 2 - Check for leaks by using a soapy solution or bubbles at each brazed location.

Note: Remove nitrogen pressure and repair any leaks before continuing.

STEP 3 - Once the initial leak check is complete, complete a system pressure test. Pressurize the system to the design pressure of the system for a minimum of 60 minutes. Do not add additional refrigerant or test gas after reaching the design pressure. The system should show no loss of pressure once pressurized. Once the pressure test is complete follow the steps for evacuation.

Section 9. Evacuation

9.1 Evacuate the Refrigerant Lines and Indoor Coil

Important: Do not open the service valves until the refrigerant lines and indoor coil leak check and evacuation are complete.

STEP 1 - Evacuate until the micron gauge reads no higher than 350 microns, then close off the valve to the vacuum pump.

STEP 2 - Observe the micron gauge. Evacuation is complete, if the micron gauge does not rise above 500 microns in one (1) minute and 1500 microns in ten (10) minutes.

Once evacuation is complete, blank off the vacuum pump and micron gauge, and close the valve on the manifold gauge set.

Section 10. Service Valves

10.1 Open the Gas Service Valve

Important: Leak check and evacuation must be completed before opening the service valves.

NOTE: Do not vent refrigerant gases into the atmosphere.

STEP 1 - Remove valve stem cap.

STEP 2 - Using an adjustable wrench, turn valve stem 1/4 turn counterclockwise to the fully open position.

STEP 3 - Replace the valve stem cap to prevent leaks. Tighten finger tight plus an additional 1/6 turn.

10.2 Open the Liquid Service Valve

⚠ WARNING

Extreme caution should be exercised when opening the Liquid Line Service Valve. Turn counterclockwise until the valve stem just touches the rolled edge. No torque is required. Failure to follow this warning will result in abrupt release of system charge and may result in personal injury and /or property damage.

Important: Leak check and evacuation must be completed before opening the service valves.

STEP 1 - Remove service valve cap.

STEP 2 - Fully insert 3/16" hex wrench into the stem and back out counterclockwise until valve stem just touches the rolled edge (approximately five (5) turns.)

STEP 3 - Replace the valve cap to prevent leaks. Tighten finger tight plus an additional 1/6 turn.

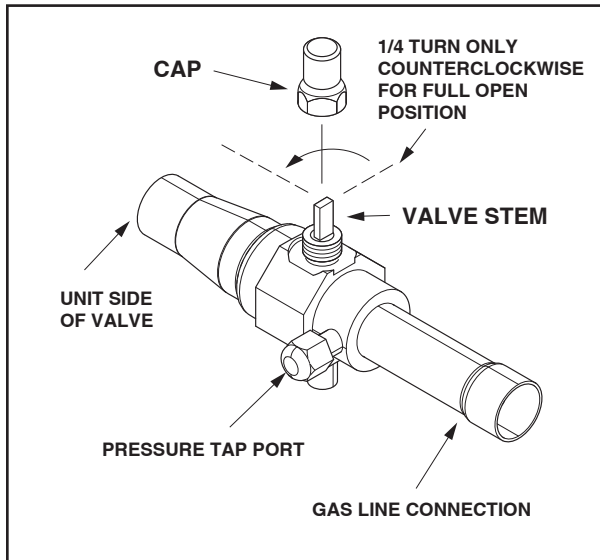

Gas Service Valve

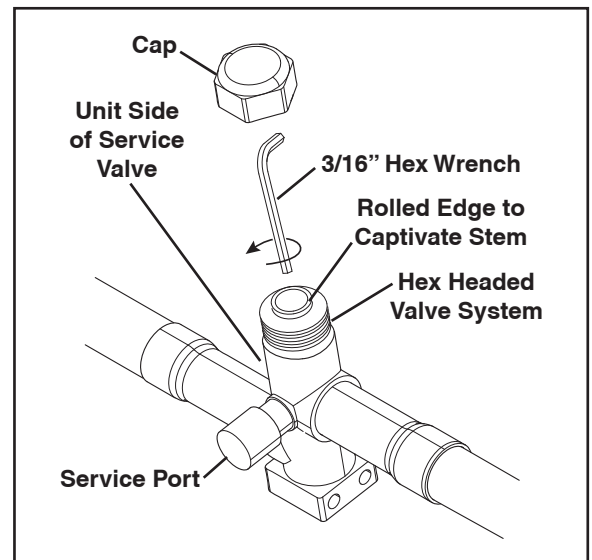

Liquid Service Valve

Section 11. Electrical – Low Voltage

11.1 Low Voltage Maximum Wire Length

Table 11.1 defines the maximum total length of low voltage wiring from the outdoor unit, to the indoor unit, and to the thermostat.

Table 11.1

24 VOLTS	
WIRE SIZE	MAX. WIRE LENGTH
18 AWG	150 Ft.
16 AWG	225 Ft.
14 AWG	300 Ft.

11.2 Low Voltage Hook-up Diagrams

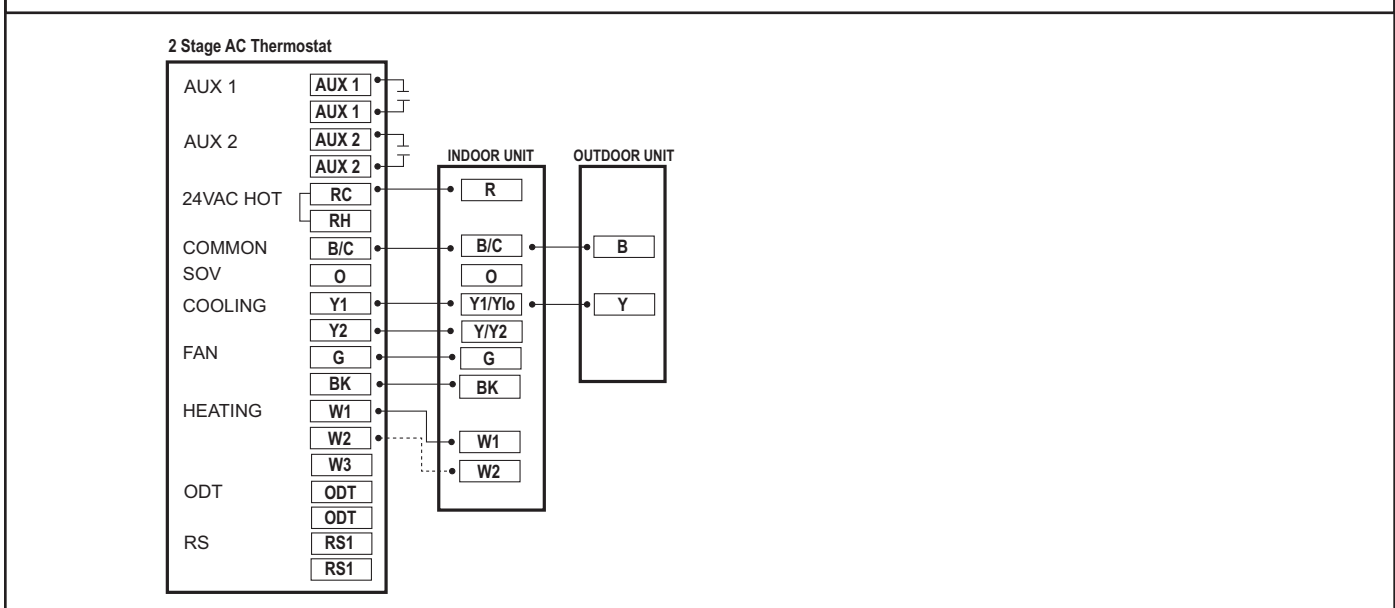
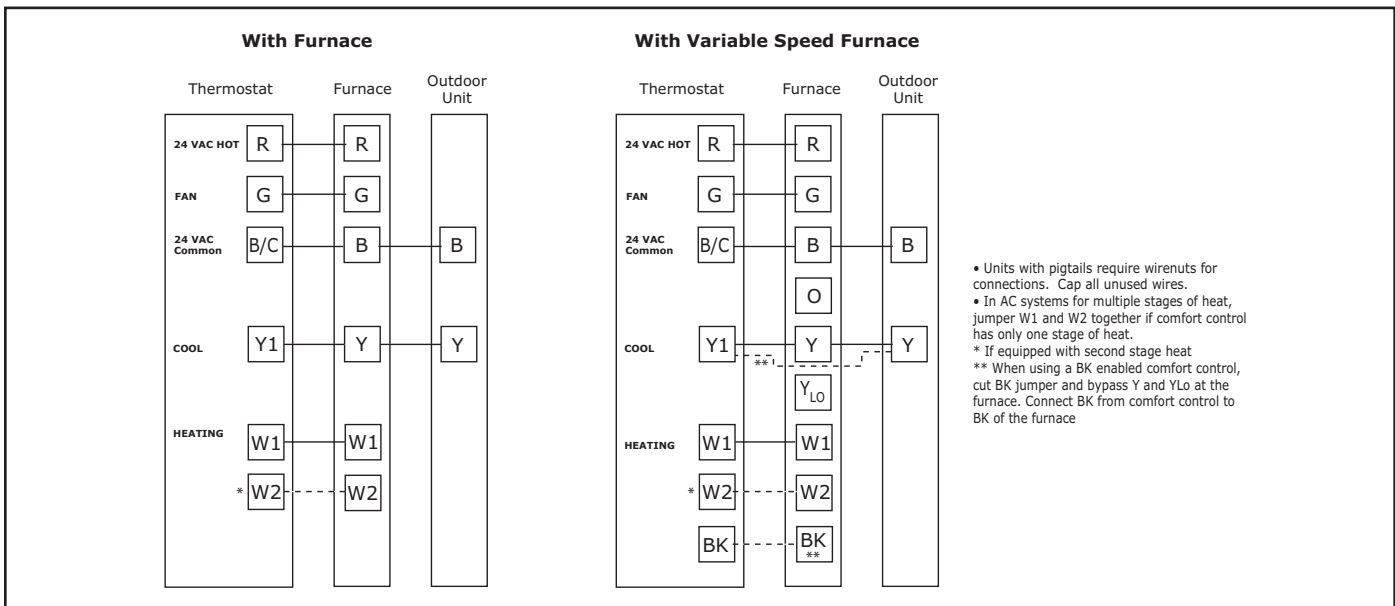
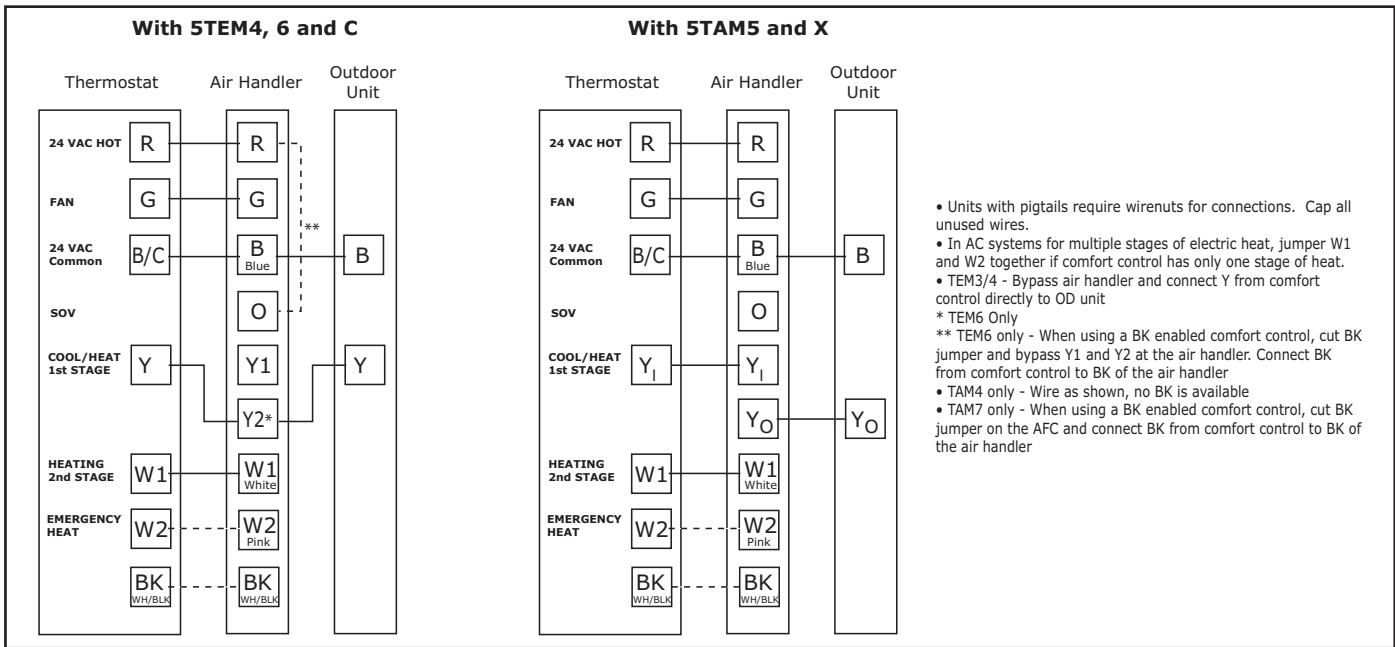

Section 12. Electrical – High Voltage

12.1 High Voltage Power Supply

⚠ WARNING

LIVE ELECTRICAL COMPONENTS!

Failure to follow this Warning could result in property damage, severe personal injury, or death. Follow all electrical safety precautions when exposed to live electrical components. It may be necessary to work with live electrical components during installation, testing, servicing, and troubleshooting of this product.

The high voltage power supply must agree with the equipment nameplate.

Check that cabling will not be subject to wear, corrosion, excessive pressure, vibration, sharp edges or any other adverse environmental effects.

Power wiring must comply with national, state, and local codes.

Follow instructions on unit wiring diagram located on the inside of the control box cover.

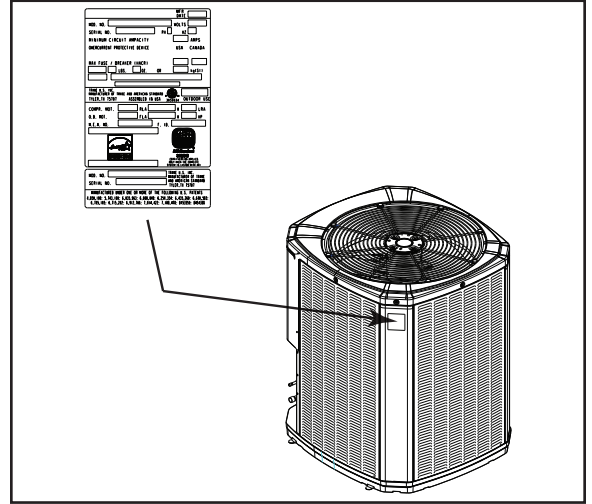

12.2 High Voltage Disconnect Switch

Install a separate disconnect switch at the outdoor unit.

For high voltage connections, flexible electrical conduit is recommended whenever vibration transmission may create a noise problem within the structure.

12.3 High Voltage Ground

Ground the outdoor unit per national, state, and local code requirements.

Section 13. Start Up

13.1 System Start Up

STEP 1 - Ensure Sections 7 through 12 have been completed.

STEP 2 - Set System Thermostat to OFF.

STEP 3 - Turn on disconnect(s) to apply power to the indoor and outdoor units.

STEP 4 - Wait one (1) hour before starting the unit if compressor crankcase heater accessory is used and the Outdoor Ambient is below 70°F.

STEP 5 - Set system thermostat to ON.

Section 14. System Charge Adjustment

14.1 Temperature Measurements (Systems can be rated with TXV, EEV or Piston. Ensure charging method is correct).

Important: Installer must mark/write the total refrigerant charge on the OD unit label after adjusting for indoor coil and lineset. Technicians must have their refrigerant cylinder on a scale during the charging procedure and measure how much additional refrigerant is put in the system (additional over the factory charge). The additional charge must be recorded on the label provided on the outdoor unit as well as the resulting total system charge.

Important: Standard service trucks and vans may not carry more than six 25# cylinders (< 220 lb of A2L refrigerant total)

Important: A2L approved equipment required for leak detection, charge and recovery.

Important: Ensure that contamination of different refrigerants does not occur when using charging equipment.

Important: A set of calibrated weighing scales shall be available and in good working order. Hoses shall be complete with leak-free disconnect couplings and in good condition. Ensure any associated electrical components are sealed.

STEP 1 - Check the outdoor temperatures.

Subcooling (in cooling mode) is the only recommended* method of charging above 55° F ambient outdoor temperature.

Note: For Superheat (In Cooling Mode), refer to the Superheat Charging Table on page 18.

***Weigh-In Method** can be used for initial installation, or system replacement when power is not available or when the desired temperatures for the standard charging method are outside normal bounds. See Section 14.3.

For best results the indoor temperature should be kept between 70° F to 80° F.

Note: It is important to return in the spring or summer to accurately charge the system in the cooling mode when outdoor ambient temperature is above 55° F.

14.2 Subcooling Charging in Cooling (Above 55° F Outdoor Temp.)

STEP 1 - Use the refrigerant line total length and lift measurements from Section 5.3.

Total Line Length = _____ Ft.

Vertical Change (Lift) = _____ Ft.

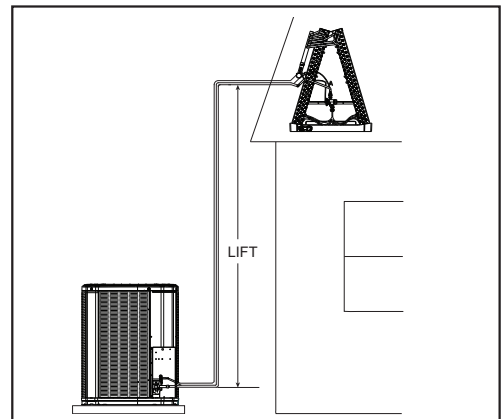

STEP 2 - Determine the final subcooling target using total Line Length and Lift measured in STEP 1 and the charts below.

018 & 030 Models

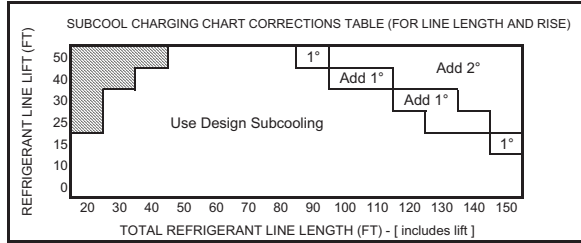

024, 036 & 042 Models

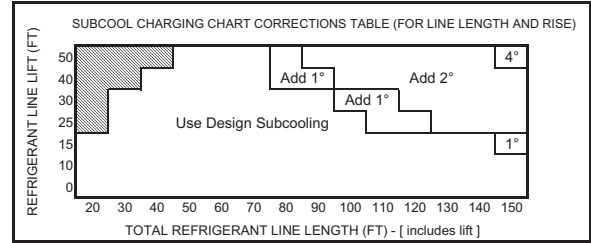

048 & 060 Models

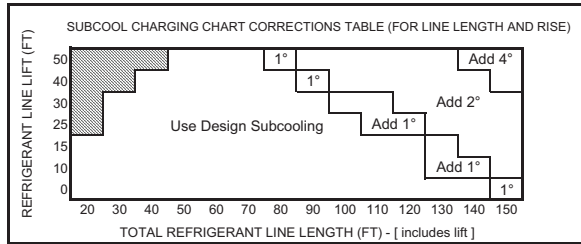

Design Subcooling Value = _____ ° F
(from nameplate or Service Facts)

Final Subcooling Target = _____ ° F

Subcooling Correction = _____ ° F

STEP 3 - Stabilize the system by operating for a minimum of 20 minutes whenever charge is removed or added before accurate measurements can be made.

STEP 4 - Measure the liquid line temperature and pressure at the outdoor unit's service valve.

Measured Liquid Line Temp = _____ ° F

Liquid Gage Pressure = _____ PSI

Final Subcooling Value = _____ ° F

STEP 5 - Use the final subcooling value, refrigerant temperature and pressure from STEP 4, to determine the proper liquid gage pressure using Table 14.2.

Example: Assume a 12° F Final Subcooling value and liquid temp of 90° F.

1. Locate 12° F Final Subcooling in Table 14.2.
2. Locate the Liquid Temperature (90° F) in the left column.
3. The Liquid Gage Pressure should be approximately 327 PSI. (This is the shown as the intersection of the Final Subcooling column and the Liquid Temperature row.)

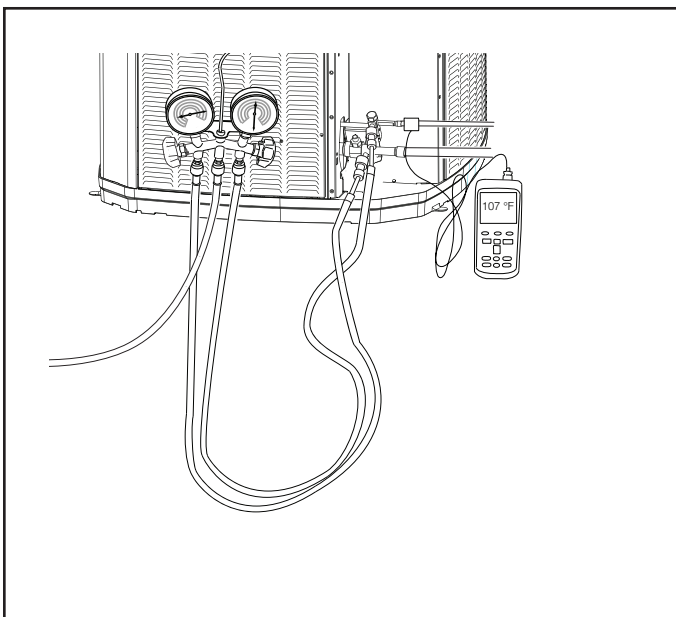

Table 14.2

R-454B REFRIGERANT CHARGING CHART							
LIQUID TEMP (°F)	DESIGN SUBCOOLING (°F)						
	8	9	10	11	12	13	14
LIQUID GAGE PRESSURE (PSI)							
55	170	172	175	178	181	184	187
60	184	187	190	194	197	200	203
65	200	203	206	210	213	217	220
70	217	220	223	227	230	234	238
75	234	238	241	245	249	252	256
80	252	256	260	264	268	272	276
85	272	276	280	284	288	292	297
90	292	297	301	305	309	314	318
95	314	318	323	327	332	336	341
100	336	341	346	351	355	360	365
105	360	365	370	375	380	385	390
110	385	390	396	401	406	412	417
115	412	417	422	428	433	439	445
120	439	445	450	456	462	468	474
125	468	474	480	486	492	498	504

STEP 6 - Adjust refrigerant level to attain proper gage pressure.

Add refrigerant if the Liquid Gage Pressure is lower than the chart value.

1. Connect gages to refrigerant bottle and unit as illustrated.
2. Purge all hoses.
3. Open bottle.
4. Stop adding refrigerant when liquid line temperature and Liquid Gage Pressure matches the charging chart Final Subcooling Target.

Recover refrigerant if the Liquid Gage Pressure is higher than the chart value.

STEP 7 - Stabilize the system.

1. Wait 20 minutes for the system condition to stabilize between adjustments.

Note: When the Liquid Line Temperature and Gage Pressure approximately match the chart, the system is properly charged.

2. Remove gages.
3. Replace service port caps to prevent leaks. Tighten finger tight plus an additional 1/6 turn.

STEP 8 - Verify typical performance.

Refer to System Pressure Curves at the end of the document to verify typical performance.

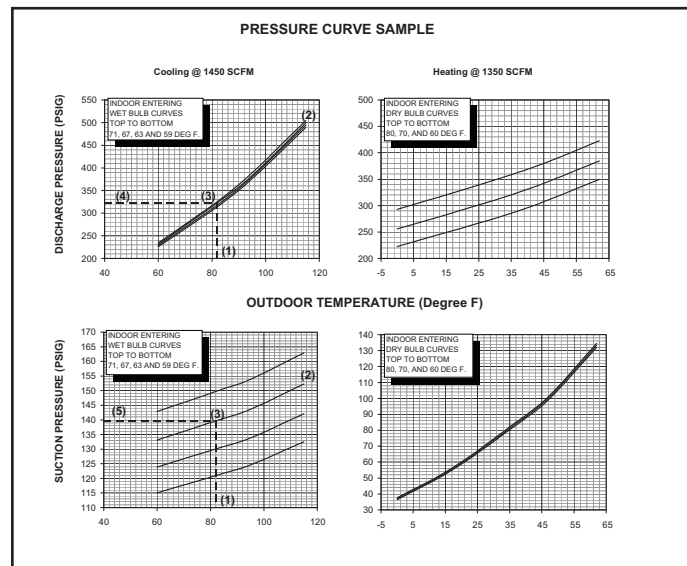
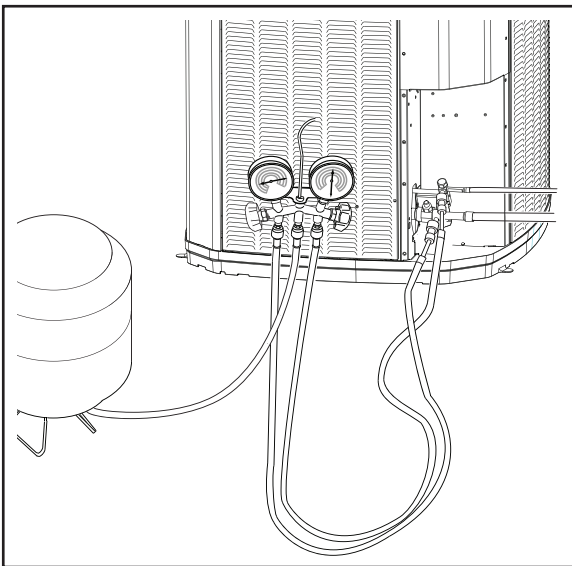

STEP 9 - Record System Information for reference.

Record system pressures and temperatures after charging is complete.

Outdoor model number = _____

Measured Outdoor Ambient = _____ ° F

Measured Indoor Ambient = _____ ° F

Measured Liquid Line Temp = _____ ° F

Measured Suction Line Temp = _____ ° F

Liquid Gage Pressure = _____ PSI

Suction Gage Pressure = _____ PSI

STEP 10 - If repairs must be made after system is charged, properly and safely remove and isolate refrigerant and purge the section of the system needing repair with oxygen free nitrogen prior to opening the circuit.

The refrigerant charge should be recovered into the correctly marked recovery cylinders. Ensure that the correct number of cylinders for holding the total system charge is available. Only use cylinders designated for the recovered refrigerant and labelled for that refrigerant. Cylinders shall be complete with pressure-relief valve and associated shut-off valves in good working order.

Ensure that the outlet for the vacuum pump is not close to any potential ignition sources and that ventilation is available.

The recovered refrigerant shall be returned to the refrigerant supplier in the correct recovery cylinder. Do not mix refrigerants.

If compressors or compressor oils are to be removed, ensure that they have been evacuated to an acceptable level to make certain that **FLAMMABLE REFRIGERANT** does not remain within the lubricant.

Nitrogen Purge Times				
Flow Rate	Lineset Length			
CuFT/Hr	< 50 feet	< 100 feet	< 150 feet	< 200 feet
15	2 Minutes	4 Minutes	6 Minutes	8 Minutes
30	1 Minute	2 Minutes	3 Minutes	4 Minutes
60	1 Minute	1 Minute	2 Minutes	2 Minutes

Fixed Orifice Superheat Charging Table

	Indoor Wet Bulb Temp (F)																														
	50	51	52	53	54	55	56	57	58	59	60	61	62	63	64	65	66	67	68	69	70	71	72	73	74	75	76	77	78		
Outdoor Dry Bulb Temp. (F)	55	7	9	10	11	12	14	15	17	18	20	21	23	24	26	27	29	30													
	60	5	7	8	9	10	12	13	15	16	18	19	21	22	24	25	27	28	30	31											
	65			4	6	8	10	11	13	14	16	17	18	19	21	22	24	25	27	28	27	31									
	70				5	7	8	10	11	13	14	16	17	18	19	21	22	24	25	27	28	30	31								
	75						5	6	7	9	10	12	14	16	18	19	21	22	24	26	28	29	31	32							
	80								4	6	7	9	10	11	12	14	16	18	19	21	23	25	26	28	29	31	33				
	85										4	6	7	9	10	13	14	16	18	20	21	23	24	26	28	29	30	31	32		
	90											4	6	8	10	11	13	14	16	18	20	22	24	25	27	28	30	31			
	95												4	6	8	10	11	13	14	16	18	20	22	23	25	26	28	29			
	100															6	8	10	12	13	16	18	20	21	23	25	27	29			
	105																4	6	7	9	11	13	15	18	20	22	24	26	28		
	110																	4	7	9	11	13	16	18	21	23	26	28			
	115																			6	9	12	14	16	19	21	24	26			

Using a digital psychrometer, measure the return air wet-bulb temperature at the unit just before the coil. Also measure the outdoor dry-bulb temperature. Use these temperatures to locate the target superheat on the charging table. Do not attempt to charge the system if these conditions fall outside of this charging table.

ADD refrigerant to DECREASE total superheat. REMOVE refrigerant to INCREASE total superheat. Always allow 10 to 15 minutes of operation after any refrigerant or air flow change prior to determining the final superheat.

14.3 Weigh-In Method for Charging

Weigh-In Method can be used for the initial installation, or anytime a system charge is being replaced. Weigh-In Method can also be used when power is not available to the equipment site or operating conditions (indoor/outdoor temperatures) are not in range to verify with the subcooling charging method.

Calculating Charge Using the Weigh-In Method

STEP 1 – Measure in feet the distance between the outdoor unit and the indoor unit and record on Line 1. Include the entire length of the line from the service valve to the IDU.

STEP 2 – Enter the charge multiplier (0.47 oz./ft for 3/8" & 0.30 oz./ft for 5/16"). Each linear foot of interconnecting tubing requires the addition of 0.6 oz of refrigerant.

STEP 3 – Multiply the total length of refrigerant tubing (Line 1) times the value on Step 2. Record the result on Line 3 of the Worksheet.

STEP 4 – This is the amount of refrigerant to weigh-in prior to opening the service valves.

- | | |
|----------------------|--|
| 1. Line length (ft) | _____ |
| 2. Charge multiplier | = for 3/8", use 0.47 oz. per foot and for 5/16", use 0.30 oz. per foot |
| 3. Step 1 x Step 2 | = _____ |
| 4. Refrigerant | = _____ |

Section 15. Checkout Procedures

15.1 Operational And Checkout Procedures

Final phases of this installation are the unit Operational and Checkout Procedures. To obtain proper performance, all units must be operated and charge adjustments made.





Important: Perform a final unit inspection to be sure that factory tubing has not shifted during shipment. Adjust tubing if necessary so tubes do not rub against each other when the unit runs. Also be sure that wiring connections are tight and properly secured.

CHECKOUT PROCEDURE

After installation has been completed, it is recommended that the entire system be checked against the following list:

- | | |
|---|--|
| 1. Leak check refrigerant lines. [] | 7. Be sure that indoor coil drain line drains freely. Pour water into drain pan..... [] |
| 2. Properly insulate suction lines and fittings..... [] | 8. Be sure that supply registers and return grilles are open and unobstructed..... [] |
| 3. Properly secure and isolate all refrigerant lines..... [] | 9. Be sure that a return air filter is installed..... [] |
| 4. Seal passages through masonry.
If mortar is used, prevent mortar from coming into direct contact with copper tubing. [] | 10. Be sure that the correct airflow setting is used. (Indoor blower motor) [] |
| 5. Verify that all electrical connections are tight..... [] | 11. Operate complete system in each mode to ensure safe operation..... [] |
| 6. Observe outdoor fan during on cycle for clearance and smooth operation..... [] | 12. Check that MCB or RDS is operational.. [] |

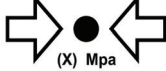
15.2 Markings and Instructions

	[symbol ISO 7010-W021 (2011-05)]	warning; flammable materials
	[symbol ISO 7000-1659 (2004-01)]	service indicator; read technical manual
	A2L symbol	warning; low burning velocity material
	[symbol ISO 7000-1701 (2004-01)]	pressure
	[symbol IEC 60417-6040 2010-08]	ultraviolet radiation, instructional safeguard
	[symbol ISO 7000-1641 (2004-01)]	operator's manual; operating instructions

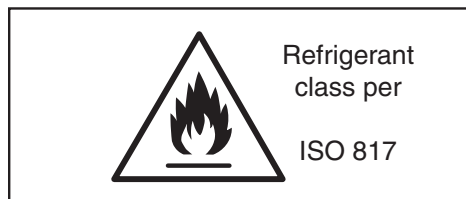

Section 16. Refrigeration Circuits

018, 030 & 042 Models

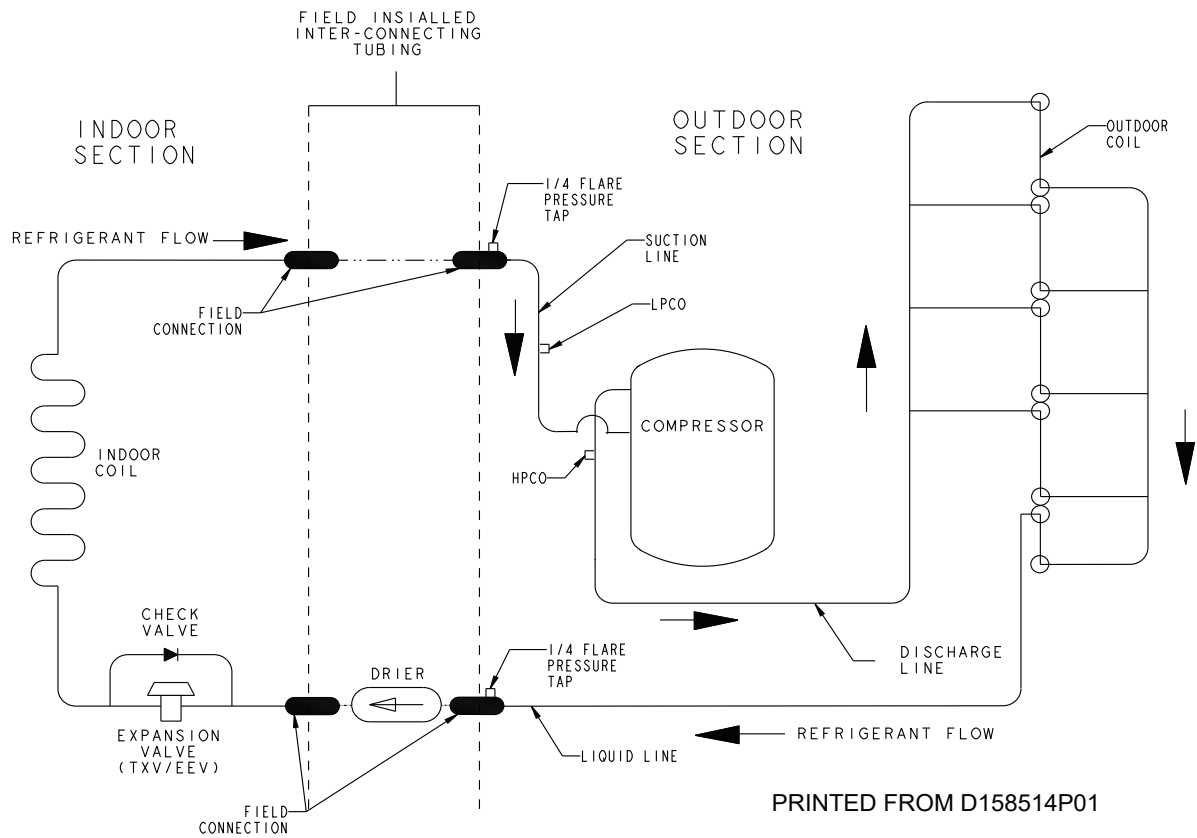

024 & 036 Models

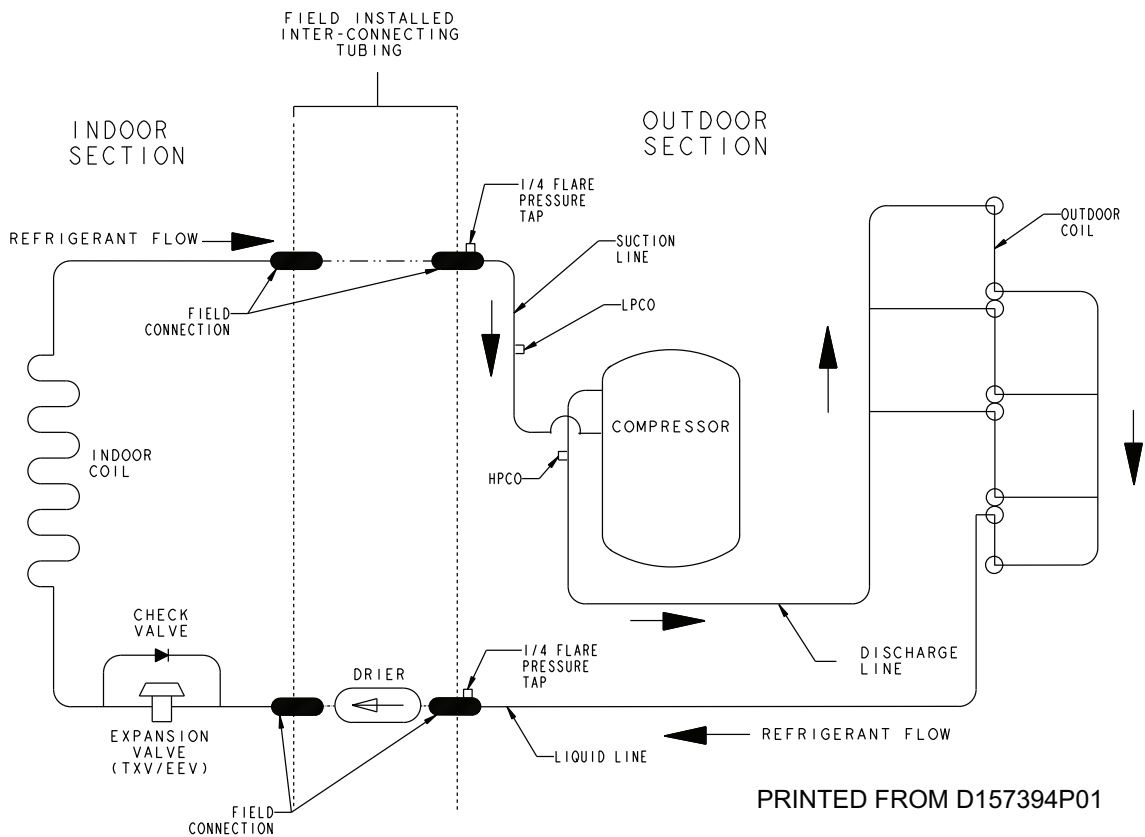

048 & 060 Models

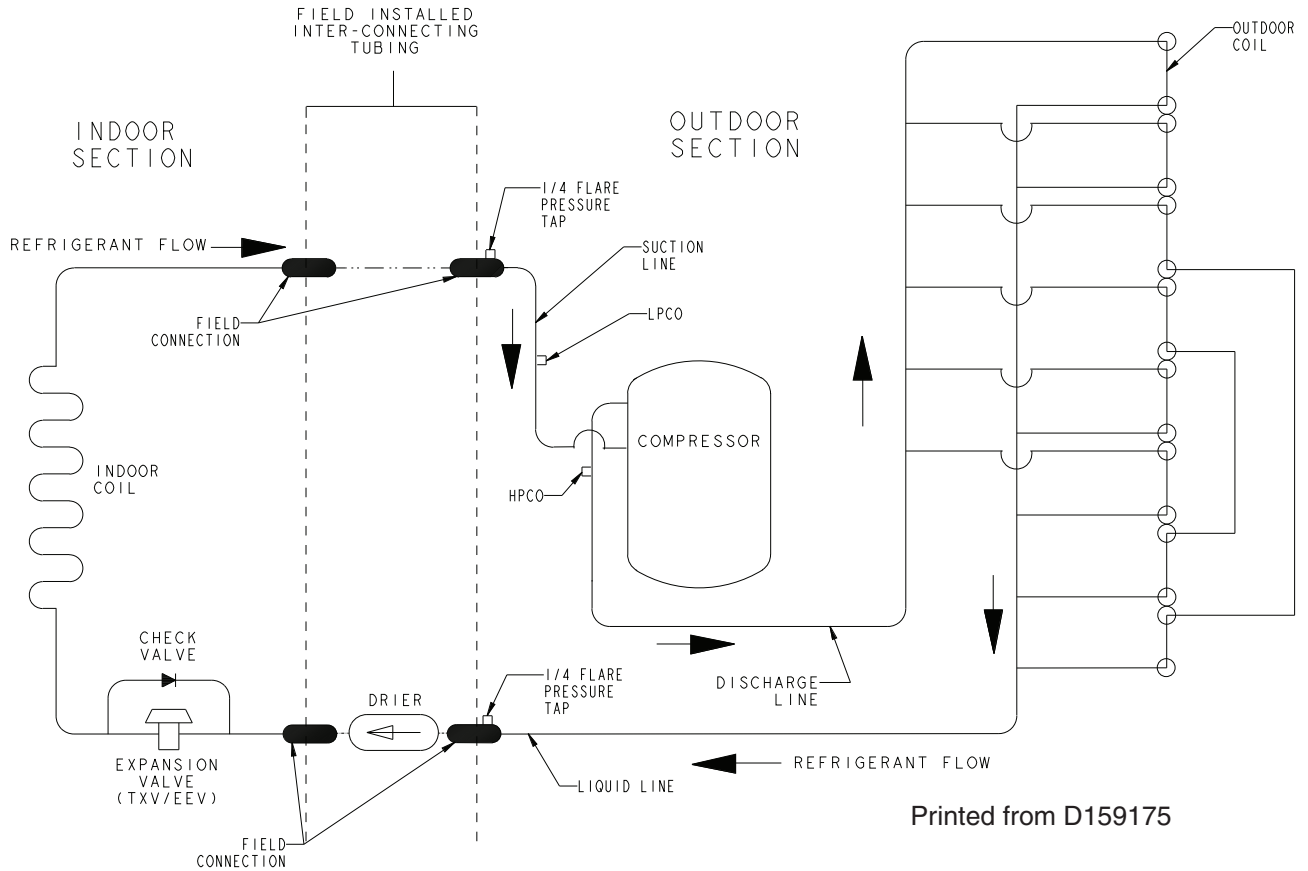

Printed from D159175

16.1 Refrigerant Detection System

The approved ID/OD combination will provide sufficient safe ventilation.

Airflow provided is sufficient to cover minimum room area including adjustments for altitude. All systems require a refrigerant detection system so no altitude adjustment factors are required.

Installer must ensure refrigerant detection system is connected and placed in appropriate orientation per application.

The control system power shall not be interrupted to ensure the refrigerant detection system is always functioning.

Please reference Indoor Unit installers guide for correct specification on refrigerant detection system.

Section 17. Wiring Diagrams

018 – 048 Models

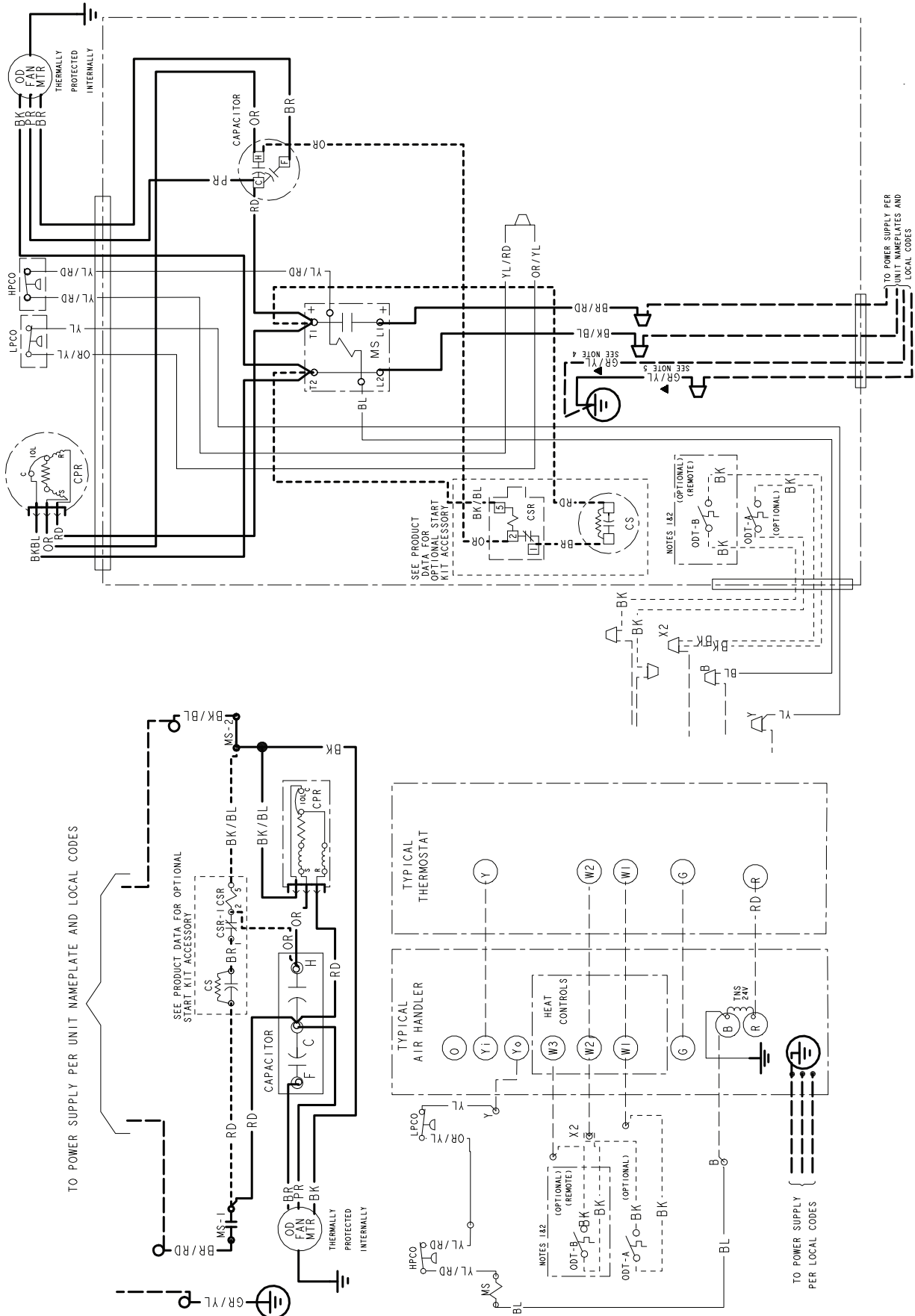

PRINTED FROM DI57362P08 REV C

NOTES:













1. IF ODT-B IS NOT USED. ADD JUMPER BETWEEN W2 & W3 AT AIR HANDLER. IF USED, ODT-B MUST BE MOUNTED REMOTE OF CONTROL BOX IN AN APPROVED WEATHER PROOF ENCLOSURE.
2. IF ODT-A IS NOT USED. ADD JUMPER BETWEEN W1 & W2 AT AIR HANDLER.
3. LOW VOLTAGE (24 V) FIELD WIRING MUST BE 18 AWG MIN.
4. USE COOPER CONDUCTOR ONLY.













FOR CANADIAN INSTALLATIONS
POUR INSTALLATIONS CANADIENNES



CAUTION: NOT SUITABLE FOR USE ON SYSTEMS EXCEEDING 150V-TO-GROUND
ATTENTION: NE CONVIENT PAS AUX INSTALLATIONS DE PLUS DE 150 V A LA TERRE

LEGEND

- CF FAN CAPACITOR
- CN WIRECONNECTOR
- CPR COMPRESSOR
- CR RUN CAPACITOR
- CS STARTING CAPACITOR
- CSR CAPACITOR SWITCHING RELAY
- F INDOOR FAN RELAY
- HPCO HIGH PRESSURE CUTOUT SWITCH
- LPCO LOW PRESSURE CUTOUT SWITCH
- IOL INTERNAL OVERLOAD PROTECTOR
- SM SYSTEM ON-OFF SWITCH
- MS COMPRESSOR MOTOR CONTACTOR
- ODA OUTDOOR ANTICIPATOR
- OFT OUTDOOR FAN THERMOSTAT
- ODS OUTDOOR TEMPERATURE SENSOR
- ODT OUTDOOR THERMOSTAT
- SC SWITCH OVER VALVE SOLENOID
- TDL DISCHARGE LINE THERMOSTAT
- TNS TRANSFORMER

-  MAGNETIC COIL
-  GROUND
-  JUNCTION
-  CAPACITOR
-  WIRE NUT OR TERMINAL
-  TRANSFORMER
-  FUSE
-  TERMINAL BLOCK/BOARD
-  RELAY CONTACT (N.O)
-  RELAY CONTACT (N.C)
-  — X — 24 V } FIELD INSTALLED
-  — X — LINE V } FACTORY WIRING

-  THERMISTOR
-  TEMP ACTUATED SWITCH
-  INTERNAL OVERLOAD PROTECTION
-  PRESSURE ACTUATED SWITCH
-  RESISTER OR HEATING ELEMENT
-  MOTOR WINDING
-  POL. PLUG FEMALE HOUSING (MALE TERMINALS)
-  POL. PLUG MALE HOUSING (FEMALE TERMINALS)
-  24 V } FACTORY WIRING
-  LINE V }
-  24 V } FIELD WIRING
-  LINE V }
-  - - - - - FIELD INSTALLED FACTORY WIRING

 COLOR OF WIRE
 BK/BL
 COLOR OF MARKER

- | | | |
|----------|-----------------|-----------|
| BK BLACK | RD RED | OR ORANGE |
| BL BLUE | WH WHITE | GR GREEN |
| BR BROWN | YL YELLOW | PR PURPLE |
| PK PINK | LTBL LIGHT BLUE | |

▲ NOTE:

- MATERIAL: WHITE POLYPROPYLENE SUITABLE FOR USE IN OUTDOOR ENVIRONMENT.
- ADHESIVE: PRESSURE SENSITIVE ADHESIVE WITH RELEASE PAPER SUITABLE FOR OUTDOOR APPLICATION ON PAINTED OR GALVANIZED SHEET METAL SURFACES.
- SIZE: 8 1/2" X 11"

Section 18. Pressure Curves

COOLING PERFORMANCE CAN BE CHECKED WHEN THE OUTDOOR TEMP IS ABOVE 65 DEG F.

TO CHECK COOLING PERFORMANCE, SELECT THE PROPER INDOOR CFM, ALLOW PRESSURES TO STABILIZE. MEASURE INDOOR WET BULB TEMPERATURE, OUTDOOR TEMPERATURE, LIQUID AND SUCTION PRESSURES. ON THE PLOTS LOCATE OUTDOOR TEMPERATURE (1);

LOCATE INDOOR WET BULB (2); FIND INTERSECTION OF OD TEMP. & ID W.B. (3); READ LIQUID (4) OR SUCTION (5) PRESSURE IN LEFT COLUMN.

EXAMPLE: (1) OUTDOOR TEMP. 82 F.

(2) INDOOR WET BULB 67 F.

(3) AT INTERSECTION

(4) LIQUID PRESSURE @ 600 CFM IS 304 PSIG

(5) SUCTION PRESSURE @ 600 CFM IS 145 PSIG

ACTUAL:

LIQUID PRESSURE SHOULD BE +/- 10 PSI OF CHART

SUCTION PRESSURE SHOULD BE +/- 3 PSIG OF CHART

PRESSURE CURVES (Refer below table for models)

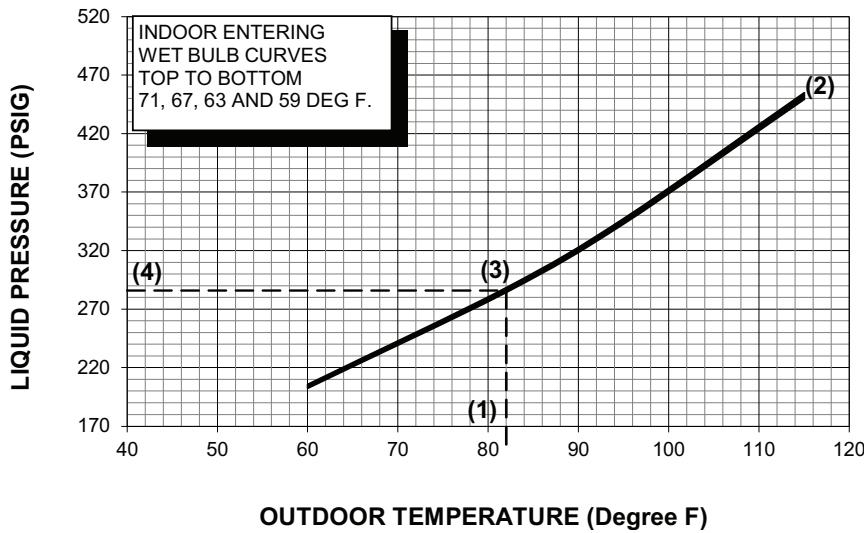

OD Model	Cooling @SCFM
5TTX5018A1	600

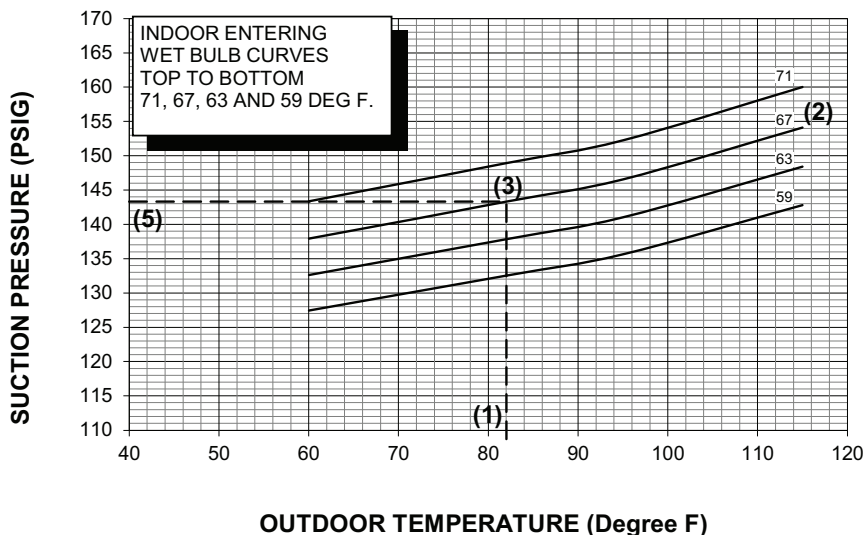

PRESSURE CURVES (Refer below table for models)

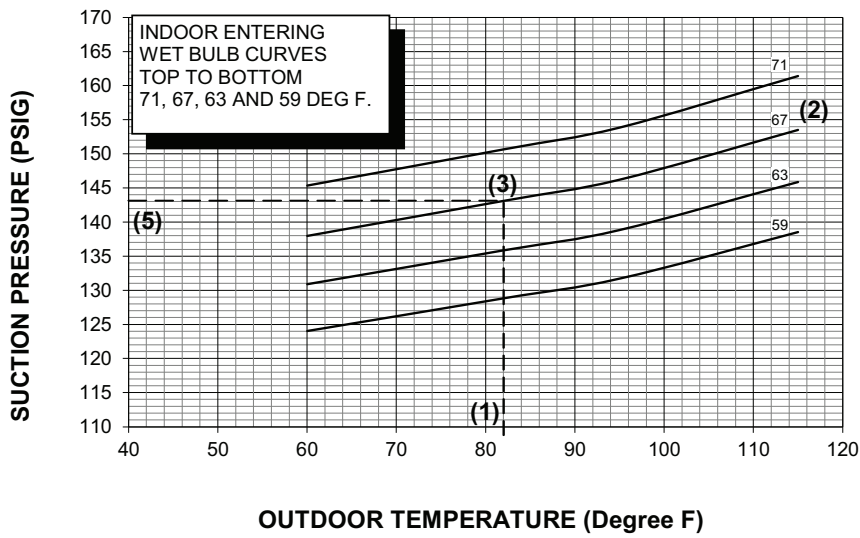
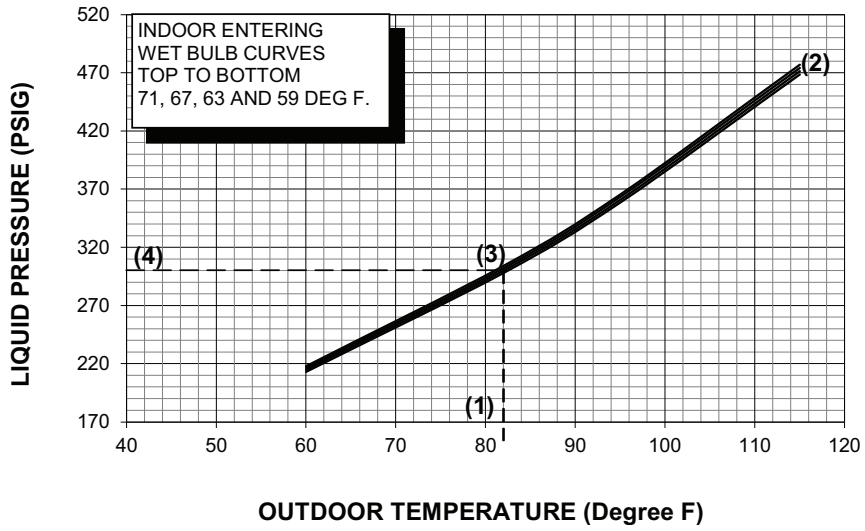

OD Model	Cooling @SCFM
5TTX5024A1	750
5TTX5030A1	850
5TTX5036A1	950
5TTX5042A1	1150
5TTX5048A1	1350

PRESSURE CURVES (Refer below table for models)

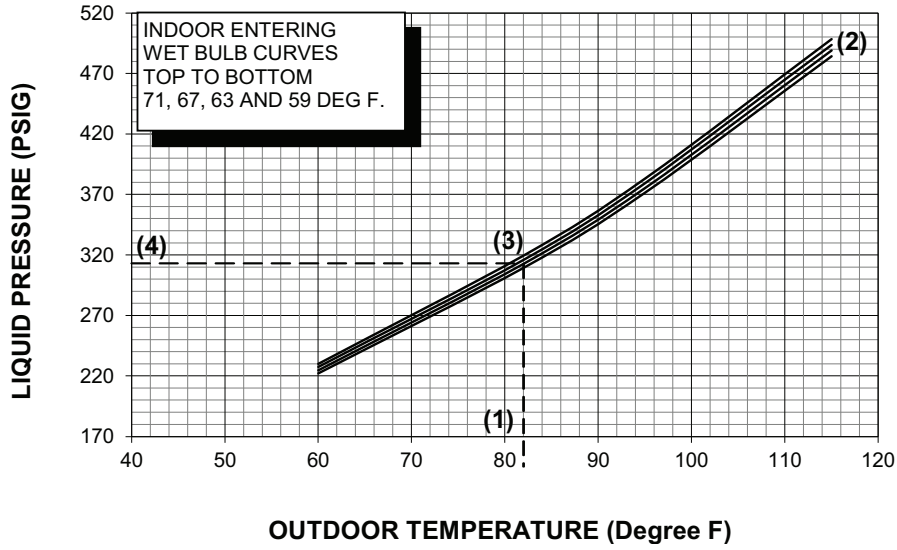

OD Model	Cooling @SCFM
5TTX5060A1	1450

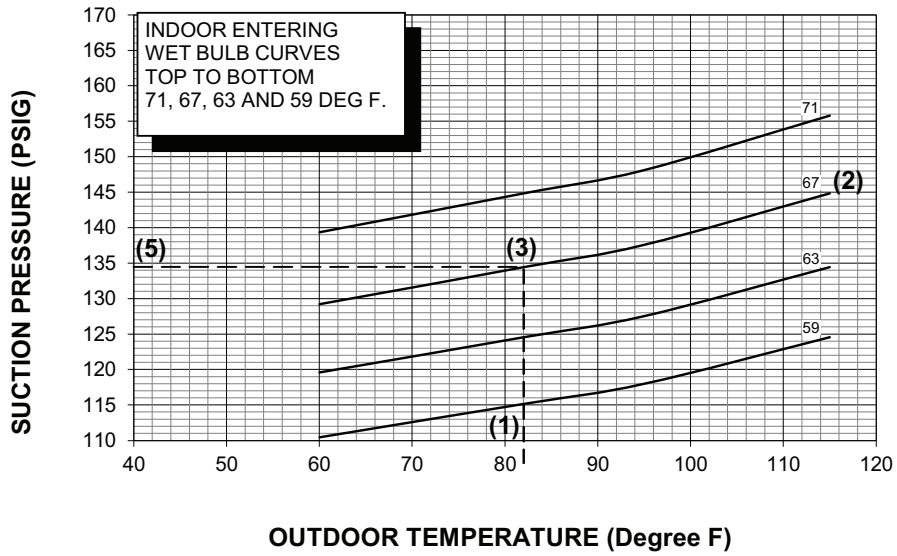



Trane - by Trane Technologies (NYSE: TT), a global climate innovator - creates comfortable, energy efficient indoor environments for commercial and residential applications. For more information, please visit trane.com or tranetechnologies.com.

18-AC130D1-1B-EN 14 Aug 2023
Supersedes 18-AC130D1-1A-EN (February 2023)



The AHRI Certified mark indicates Trane U.S. Inc. participation in the AHRI Certification program. For verification of individual certified products, go to ahridirectory.org.

Trane has a policy of continuous data improvement and it reserves the right to change design and specifications without notice. We are committed to using environmentally conscious print practices.

© 2023 Trane