

Installation, Operation, and Maintenance

Convertible Air Handlers 2 to 5 Ton

5TEM4B02AC21SA
5TEM4B04AC31SA
5TEM4D06AC41SA
5TEM4D07AC51SA



5TEM4B03AC31SA
5TEM4D03AC41SA
5TEM4D05AC41SB

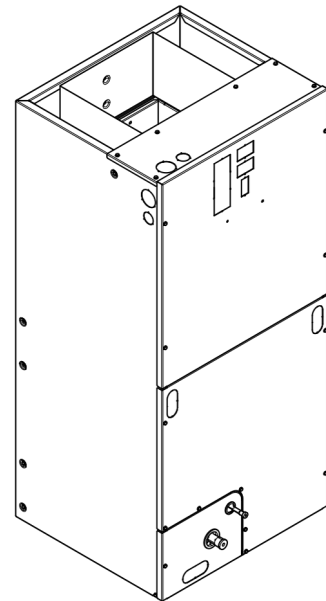

*Note: Graphics in this document are for representation only.
Actual model may differ in appearance.*

⚠ SAFETY WARNING

Only qualified personnel should install and service the equipment. The installation, starting up, and servicing of heating, ventilating, and air-conditioning equipment can be hazardous and requires specific knowledge and training. Improperly installed, adjusted or altered equipment by an unqualified person could result in death or serious injury. When working on the equipment, observe all precautions in the literature and on the tags, stickers, and labels that are attached to the equipment.

Introduction

Read this manual thoroughly before operating or servicing this unit.

This document is customer property and is to remain with this unit. Return to the service information pack upon completion of work.

Warnings, Cautions, and Notices

Safety advisories appear throughout this manual as required. Your personal safety and the proper operation of this machine depend upon the strict observance of these precautions.

The three types of advisories are defined as follows:



Indicates a potentially hazardous situation which, if not avoided, could result in death or serious injury.



Indicates a potentially hazardous situation which, if not avoided, could result in minor or moderate injury. It could also be used to alert against unsafe practices.



Indicates a situation that could result in equipment or property-damage only accidents.

Important Environmental Concerns

Scientific research has shown that certain man-made chemicals can affect the earth's naturally occurring stratospheric ozone layer when released to the atmosphere. In particular, several of the identified chemicals that may affect the ozone layer are refrigerants that contain Chlorine, Fluorine and Carbon (CFCs) and those containing Hydrogen, Chlorine, Fluorine and Carbon (HCFCs). Not all refrigerants containing these compounds have the same potential impact to the environment. Trane advocates the responsible handling of all refrigerants.

Important Responsible Refrigerant Practices

Trane believes that responsible refrigerant practices are important to the environment, our customers, and the air conditioning industry. All technicians who handle refrigerants must be certified according to local rules. For the USA, the Federal Clean Air Act (Section 608) sets forth the requirements for handling, reclaiming, recovering and recycling of certain refrigerants and the equipment that is used in these service procedures. In addition, some states or municipalities may have additional requirements that must also be adhered to for responsible management of refrigerants. Know the applicable laws and follow them.

⚠ WARNING

Proper Field Wiring and Grounding Required!

Failure to follow code could result in death or serious injury.

All field wiring **MUST** be performed by qualified personnel. Improperly installed and grounded field wiring poses **FIRE** and **ELECTROCUTION** hazards. To avoid these hazards, you **MUST** follow requirements for field wiring installation and grounding as described in **NEC** and your local/state/national electrical codes.

⚠ WARNING

Personal Protective Equipment (PPE) Required!

Failure to wear proper PPE for the job being undertaken could result in death or serious injury.

Technicians, in order to protect themselves from potential electrical, mechanical, and chemical hazards, **MUST** follow precautions in this manual and on the tags, stickers, and labels, as well as the instructions below:

- **Before installing/servicing this unit, technicians MUST put on all PPE required for the work being undertaken (Examples; cut resistant gloves/sleeves, butyl gloves, safety glasses, hard hat/bump cap, fall protection, electrical PPE and arc flash clothing). ALWAYS refer to appropriate Safety Data Sheets (SDS) and OSHA guidelines for proper PPE.**
- **When working with or around hazardous chemicals, ALWAYS refer to the appropriate SDS and OSHA/GHS (Global Harmonized System of Classification and Labelling of Chemicals) guidelines for information on allowable personal exposure levels, proper respiratory protection and handling instructions.**
- **If there is a risk of energized electrical contact, arc, or flash, technicians MUST put on all PPE in accordance with OSHA, NFPA 70E, or other country-specific requirements for arc flash protection, PRIOR to servicing the unit. NEVER PERFORM ANY SWITCHING, DISCONNECTING, OR VOLTAGE TESTING WITHOUT PROPER ELECTRICAL PPE AND ARC FLASH CLOTHING. ENSURE ELECTRICAL METERS AND EQUIPMENT ARE PROPERLY RATED FOR INTENDED VOLTAGE.**

⚠ WARNING**Follow EHS Policies!**

Failure to follow instructions below could result in death or serious injury.

- All Tranepersonnel must follow the company's Environmental, Health and Safety (EHS) policies when performing work such as hot work, electrical, fall protection, lockout/tagout, refrigerant handling, etc. Where local regulations are more stringent than these policies, those regulations supersede these policies.
- Non-Tranepersonnel should always follow local regulations.

⚠ WARNING**Cancer and Reproductive Harm!**

This product can expose you to chemicals, including lead, which are known to the State of California to cause cancer and birth defects or other reproductive harm. For more information go to www.P65Warnings.ca.gov.

⚠ WARNING**Safety Hazard!**

Failure to follow instructions below could result in death or serious injury or property damage.

This unit is not to be used by persons (including children) with reduced physical, sensory, or mental capabilities, or lack of experience and knowledge, unless they have been given supervision or instruction concerning the use of the appliance by a person responsible for their safety.

Do not allow children to play or climb on the unit or to clean or maintain the unit without supervision.

⚠ WARNING**Safety Hazard!**

Failure to follow instructions below could result in death or serious injury or property damage.

Connect the air handler to an outdoor unit suitable for use with R-454B refrigerant only.

⚠ WARNING**Hazardous Voltage!**

Failure to disconnect power before servicing could result in death or serious injury.

Disconnect all electric power, including remote disconnects before servicing. Follow proper lockout/tagout procedures to ensure the power can not be inadvertently energized. Verify that no power is present with a voltmeter.

⚠ WARNING**Grounding Required!**

Failure to follow instructions below could result in death or serious injury, or property damage.

- Reconnect all grounding devices.
- All parts of this product that are capable of conducting electrical current are grounded.
- If grounding wires, screws, straps, clips, nuts, or washers used to complete a path to ground are removed for service, they must be returned to their original position and properly fastened.

⚠ WARNING**Risk of Fire — Flammable Refrigerant!**

Failure to follow instructions below could result in death or serious injury, and equipment damage.

- To be repaired only by trained service personnel.
- Do not puncture refrigerant tubing.
- Dispose of properly in accordance with federal or local regulations.

⚠ WARNING**Live Electrical Components!**

Failure to follow all electrical safety precautions when exposed to live electrical components could result in death or serious injury.

When it is necessary to work with live electrical components, have a qualified licensed electrician or other individual who has been properly trained in handling live electrical components perform these tasks.

⚠ WARNING**Refrigerant under High Pressure!**

Failure to follow instructions below could result in an explosion which could result in death or serious injury or equipment damage.

System contains oil and refrigerant under high pressure. Recover refrigerant to relieve pressure before opening the system. See unit nameplate for refrigerant type. Do not use non-approved refrigerants, refrigerant substitutes, or refrigerant additives.

⚠ CAUTION**Sharp Edges!**

Failure to follow instructions below could result in minor to moderate injury.

The service procedure described in this document involves working around sharp edges. To avoid being cut, technicians **MUST** put on all necessary Personal Protective Equipment (PPE), including gloves and arm guards.

⚠ CAUTION

Corrosion Hazard!

Failure to follow instructions below could result in personal injury or equipment damage.

To prevent shortening its service life, do not use air handler during the finishing phases of construction or remodeling. The low return air temperatures can lead to the formation of condensate. Condensate in the presence of chlorides and fluorides from paint and other components creates a corrosive condition which may cause rapid deterioration of the cabinet and internal components.

Copyright

This document and the information in it are the property of Trane, and may not be used or reproduced in whole or in

part without written permission. Trane reserves the right to revise this publication at any time, and to make changes to its content without obligation to notify any person of such revision or change.

Trademark

All trademarks referenced in this document are the trademarks of their respective owners.

Revision History

- Updated the model numbers across the document to remove 5TEM4D04AC31SA and to add 5TEM4D06AC41SB.
- Added a new electrical data table for 5TEM4D06AC41SB.

Table of Contents

General Information	6	AirflowAdjustment.....	13
StandardFeatures.....	6	Verification of Mitigation Actions	13
OptionalAccessories.....	6	Installation Instructions	14
Installation Recommendations.....	6	FieldWiringDiagrams.....	19
InformationonServicing.....	7	External Switches and Accessories	21
PriortoBeginningWork.....	7	Performance and Electrical Data	22
Repairs to Electrical Components	7	Airflow Performance Data.....	22
Detection of Flammable Refrigerants	7	ElectricalData.....	24
RemovalandEvacuation.....	8	MinimumAirflowCFM.....	28
ChargingProcedures.....	8	HeaterPressureDropTable.....	29
Recovery.....	8	Unit Conversion Instructions	30
Decommissioning.....	9	Horizontal Left Sensor Relocation.....	30
DimensionalData.....	10	Downflow.....	31
WiringDiagram.....	11	HorizontalRight.....	34
Refrigerant Leak Detection System	12	CheckoutProcedures.....	39
Minimum Conditioned Space	12		

General Information

Standard Features

- Multi-position upflow, downflow, horizontal left, and horizontal right
- Painted finish on galvanized steel exterior with fully insulated cabinet that meets R4.2 value
- Sturdy polycarbonate drain pans
 - These air handlers have factory installed drain pans and are shipped for upflow applications.
- 208/230 VAC operation
- Multi-speed direct drive blower
- Factory installed R-454B thermal expansion valve
- All aluminum coil
- Bottom return
- Meets the minimum leakage requirements for Florida and California building codes

Optional Accessories

- 4,5,8,10,15,20, and 25 KW single phase electrical heaters
 - Circuit breakers available on single phase 4,5,8, 10, 15, 20, and 25 KW heaters
 - Lugs available on single phase 4,5,8, and 10 KW heaters
 - Lugs available on three phase 10 and 15 KW heaters
- Single point power entry kit (for 15 and 20 KW heaters)
- Supply duct flange kit - BAYTEMSPFG1A
- Downflow sub-base kits - TAYBASE185, TAYBASE235, TAYBASE260
- Slim fit filter box kit - BAYSF1185AAA, BAYSF1235AAA, BAYSF1265AAA
- Breaker seal kit - TEMBRKSEALKT01A
- Downflow condensate management kit - BAYTEMDFKT1A

- CleanEffects whole house air cleaners - EFD175DLAH000B, EFD215DLAH000B, EFD235DLAH000B

Installation Recommendations

The 5TEM4 series air handler is designed for installation in a closet, utility room, alcove, basement, crawlspace or attic. These versatile units are applicable to air conditioning and heat pump applications. Several models are available to meet the specific requirements of the outdoor equipment. Field installed electric resistance heaters are available.

Important: *Installation of this unit shall be made in accordance with the National Electric Code, NFPA No. 90A and 90B, and any other local codes or utilities requirements.*

Notes:

- *Air handlers have been evaluated in accordance with the Code of Federal Regulations, Chapter XX, Part 3280 or the equivalent. "SUITABLE FOR MOBILE HOME USE."*
- *Condensation may occur on the surface of the air handler when installed in an unconditioned space. When units are installed in unconditioned spaces, verify that all electrical and refrigerant line penetrations on the air handler are sealed completely.*
- *The manufacturer recommends installing ONLY A.H.R.I approved, matched indoor and outdoor systems. Some of the benefits of installing approved matched indoor and outdoor split systems are maximum efficiency, optimum performance, and the best overall system reliability.*
- *There is no declared maximum altitude for operating the appliance.*
- *Charging of the refrigerating system shall be according to the instructions provided by the manufacturer of the outdoor unit.*

Information on Servicing

All replacement parts shall be in accordance with the manufacturer's specifications.

Prior to Beginning Work

Prior to beginning work on systems containing flammable refrigerants, safety checks are necessary to ensure that the risk of ignition is minimized. For repair to the refrigerating system, the following shall be completed prior to conducting work on the system:

- Work shall be undertaken under a controlled procedure to minimize the risk of a flammable gas or vapor being present while the work is being performed.
- All maintenance staff and others working in the local area shall be instructed on the nature of work being carried out. Work in confined spaces shall be avoided.
- There shall be checked with an appropriate refrigerant detector prior to and during work, to ensure the technician is aware of potentially toxic or flammable atmospheres. Ensure that the leak detection equipment being used is suitable for use with all applicable refrigerants, i.e., non-sparking, adequately sealed or intrinsically safe.
- If any hot work is to be conducted on the refrigerating equipment or any associated parts, appropriate fire extinguishing equipment shall be available to hand. Have a dry powder or CO₂ fire extinguisher adjacent to the charging area.
- No person carrying out work in relation to a refrigerating system which involves exposing any pipe work shall use any sources of ignition in such a manner that it may lead to the risk of fire or explosion. All possible ignition sources, including cigarette smoking, should be kept sufficiently far away from the site of installation, repairing, removing and disposal, during which refrigerant can possibly be released to the surrounding space. Prior to work taking place, the area around the equipment is to be surveyed to make sure that there are no flammable hazards or ignition risks. "No Smoking" signs shall be displayed.
- Ensure that the area is in the open or that it is adequately ventilated before breaking into the system or conducting any hot work. A degree of ventilation shall continue during the period that the work is carried out. The ventilation should safely disperse any released refrigerant and preferably expel it externally into the atmosphere.
- The following checks shall be applied to installations using flammable refrigerants:
 - marking to the equipment continues to be visible and legible. Markings and signs that are illegible shall be corrected;
 - refrigerating pipe or components are installed in a position where they are unlikely to be exposed to

any substance which may corrode refrigerant containing components, unless the components are constructed of materials which are inherently resistant to being corroded or are suitably protected against being so corroded.

Repairs to Electrical Components

Where electrical components are being changed, they shall be fit for the purpose and to the correct specification. At all times the manufacturer's maintenance and service guidelines shall be followed. If in doubt, consult the manufacturer's technical department for assistance.

Repair and maintenance to electrical components shall include initial safety checks and component inspection procedures. If a fault exists that could compromise safety, then no electrical supply shall be connected to the circuit until it is satisfactorily dealt with. If the fault cannot be corrected immediately but it is necessary to continue operation, an adequate temporary solution shall be used. This shall be reported to the owner of the equipment, so all parties are advised.

Initial safety checks shall include:

- that capacitors are discharged; this shall be done in a safe manner to avoid possibility of sparking;
- that no live electrical components and wiring are exposed while charging, recovering or purging the system;
- that there is continuity of earth bonding.

Check that cabling will not be subject to wear, corrosion, excessive pressure, vibration, sharp edges or any other adverse environmental effects. The check shall also take into account the effects of aging or continual vibration from sources such as compressors or fans.

Detection of Flammable Refrigerants

Under no circumstances shall potential sources of ignition be used in the searching for or detection of refrigerant leaks. A halide torch (or any other detector using a naked flame) shall not be used.

The following leak detection method is deemed acceptable for all refrigerant systems:

- Electronic leak detectors may be used to detect refrigerant leaks but, in the case of flammable refrigerants, the sensitivity may not be adequate, or may need re-calibration. (Detection equipment shall be calibrated in a refrigerant-free area.) Ensure that the detector is not a potential source of ignition and is suitable for the refrigerant used. Leak detection equipment shall be set at a percentage of the LFL of

Information on Servicing

the refrigerant and shall be calibrated to the refrigerant employed, and the appropriate percentage of gas (25 % maximum) is confirmed.

Example of leak detection fluids is **bubble method**.

If a leak is suspected, all naked flames shall be removed/ extinguished.

If a leakage of refrigerant is found which requires brazing, all of the refrigerant shall be recovered from the system, or isolated (by means of shut off valves) in a part of the system remote from the leak.

Removal and Evacuation

When breaking into the refrigerant circuit to make repairs - or for any other purpose - conventional procedures shall be used. However, for flammable refrigerants it is important that best practice be followed, since flammability is a consideration. The following procedure shall be adhered to:

- safely remove refrigerant following local and national regulations;
- evacuate;
- purge the circuit with inert gas (optional for A2L);
- evacuate (optional for A2L);
- continuously flush or purge with inert gas when using flame to open circuit;
- and open the circuit.

The refrigerant charge shall be recovered into the correct recovery cylinders if venting is not allowed by local and national codes. For appliances containing flammable refrigerants, the system shall be purged with oxygen-free nitrogen to render the appliance safe for flammable refrigerants.

This process might need to be repeated several times.

Compressed air or oxygen shall not be used for purging refrigerant systems.

For appliances containing flammable refrigerants, refrigerants purging shall be achieved by breaking the vacuum in the system with oxygen-free nitrogen and continuing to fill until the working pressure is achieved, then venting to atmosphere, and finally pulling down to a vacuum (optional for A2L). This process shall be repeated until no refrigerant is within the system (optional for A2L). When the final oxygen-free nitrogen charge is used, the system shall be vented down to atmospheric pressure to enable work to take place.

The outlet for the vacuum pump shall not be close to any potential ignition sources, and ventilation shall be available.

Charging Procedures

In addition to conventional charging procedures, the following requirements shall be followed.

- Ensure that contamination of different refrigerants does not occur when using charging equipment. Hoses or

lines shall be as short as possible to minimise the amount of refrigerant contained in them.

- Cylinders shall be kept in an appropriate position according to the instructions.
- Ensure that the refrigerating system is earthed prior to charging the system with refrigerant.
- Label the system when charging is complete (if not already).
- Extreme care shall be taken not to overfill the refrigerating system.

Prior to recharging the system, it shall be pressure-tested with the appropriate purging gas. The system shall be leak-tested on completion of charging but prior to commissioning. A follow up leak test shall be carried out prior to leaving the site.

See installation instructions below for further details.

Recovery

When removing refrigerant from a system, either for servicing or decommissioning, it is recommended good practice that all refrigerants are removed safely.

When transferring refrigerant into cylinders, ensure that only appropriate refrigerant recovery cylinders are employed. Ensure that the correct number of cylinders for holding the total system charge is available. All cylinders to be used are designated for the recovered refrigerant and labelled for that refrigerant (i.e., special cylinders for the recovery of refrigerant). Cylinders shall be complete with pressure-relief valve and associated shut-off valves in good working order. Empty recovery cylinders are evacuated and, if possible, cooled before recovery occurs.

The recovery equipment shall be in good working order with a set of instructions concerning the equipment that is at hand and shall be suitable for the recovery of the flammable refrigerant. If in doubt, the manufacturer should be consulted. In addition, a set of calibrated weighing scales shall be available and in good working order. Hoses shall be complete with leak-free disconnect couplings and in good condition.

The recovered refrigerant shall be processed according to local legislation in the correct recovery cylinder, and the relevant waste transfer note arranged. Do not mix refrigerants in recovery units and especially not in cylinders.

If compressors or compressor oils are to be removed, ensure that they have been evacuated to an acceptable level to make certain that flammable refrigerant does not remain within the lubricant. The compressor body shall not be heated by an open flame or other ignition sources to accelerate this process. When oil is drained from a system, it shall be carried out safely.

Decommissioning

Before carrying out this procedure, it is essential that the technician is completely familiar with the equipment and all its detail. It is recommended good practice that all refrigerants are recovered safely. Prior to the task being carried out, an oil and refrigerant sample shall be taken in case analysis is required prior to re-use of recovered refrigerant. It is essential that electrical power is available before the task is commenced.

1. Become familiar with the equipment and its operation.
2. Isolate system electrically.
3. Before attempting the procedure, ensure that:
 - a. mechanical handling equipment is available, if required, for handling refrigerant cylinders;
 - b. all personal protective equipment is available and being used correctly;
 - c. the recovery process is supervised at all times by a competent person;
 - d. recovery equipment and cylinders conform to the appropriate standards.
4. Pump down refrigerant system, if possible.
5. If a vacuum is not possible, make a manifold so that refrigerant can be removed from various parts of the system.
6. Make sure that cylinder is situated on the scales before recovery takes place.
7. Start the recovery machine and operate in accordance with instructions.
8. Do not overfill cylinders (no more than 80% volume liquid charge).
9. Do not exceed the maximum working pressure of the cylinder, even temporarily.
10. When the cylinders have been filled correctly and the process completed, make sure that the cylinders and the equipment are removed from site promptly and all isolation valves on the equipment are closed off.
11. Recovered refrigerant shall not be charged into another refrigerating system unless it has been cleaned and checked.

Equipment shall be labelled stating that it has been decommissioned and emptied of refrigerant. The label shall be dated and signed. For appliances containing flammable refrigerant, ensure that there are labels on the equipment stating the equipment contains flammable refrigerant.

Dimensional Data

Figure 1. Dimensional data

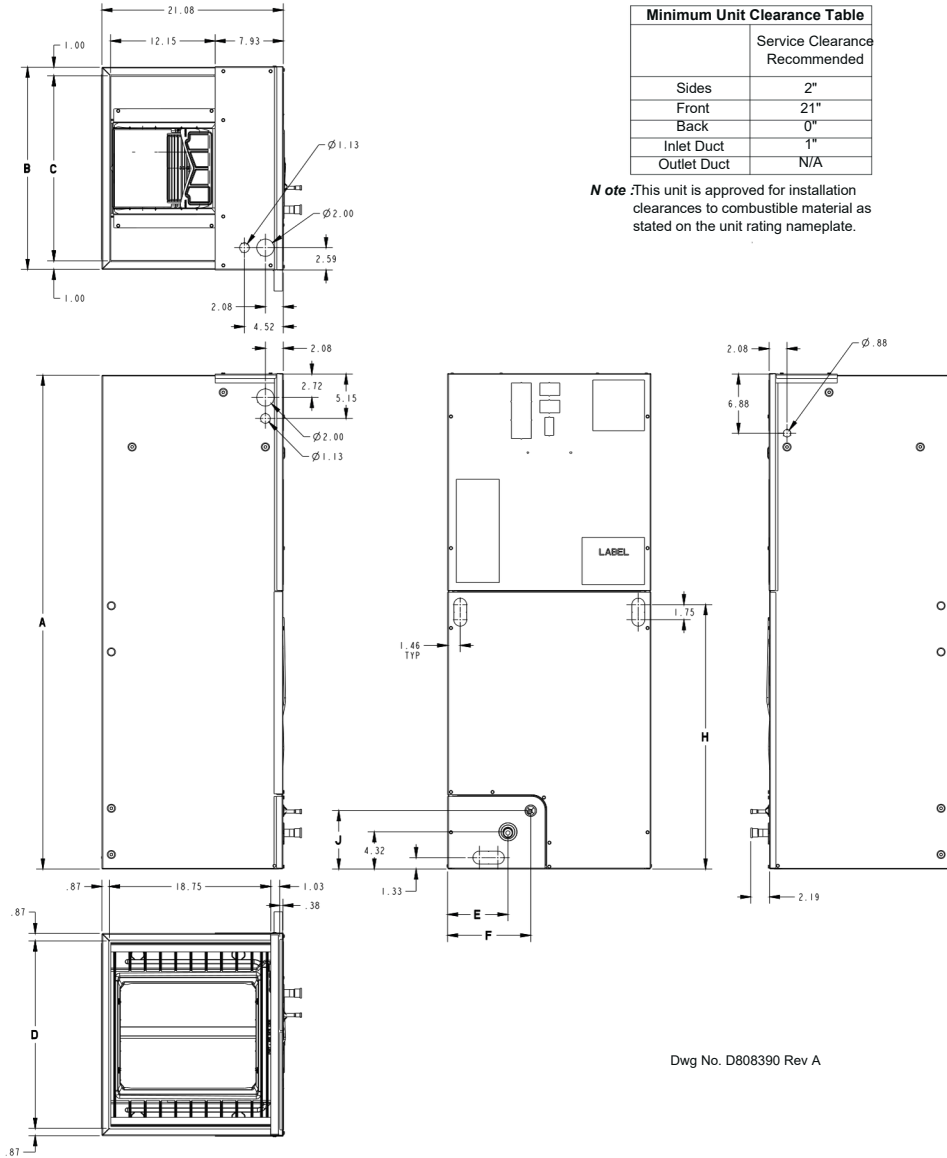

Minimum Unit Clearance Table	
	Service Clearance Recommended
Sides	2"
Front	21"
Back	0"
Inlet Duct	1"
Outlet Duct	N/A

Note: This unit is approved for installation clearances to combustible material as stated on the unit rating nameplate.

Dwg No. D808390 Rev A

Note: All dimensions are reference dimensions.

Table 1. Product dimensions (inch)

Air Handler Model	A	B	C	D	E	F	H	J	Flow Control	Gas Line Braze
5TEM4B02	45.02	18.50	16.50	16.75	5.43	7.08	18.32	5.76	TXV	3/4
5TEM4B03	46.77	18.50	16.50	16.75	5.43	7.08	20.07	5.76	TXV	3/4
5TEM4B04	51.96	18.50	16.50	16.75	5.43	7.08	24.58	5.76	TXV	7/8
5TEM4D05, D06	51.27	23.50	21.50	21.75	7.01	9.66	24.58	6.76	TXV	7/8
5TEM4D07	57.40	23.50	21.50	21.75	7.01	9.66	30.71	6.76	TXV	7/8

Wiring Diagram

Figure 2. Wiring diagram

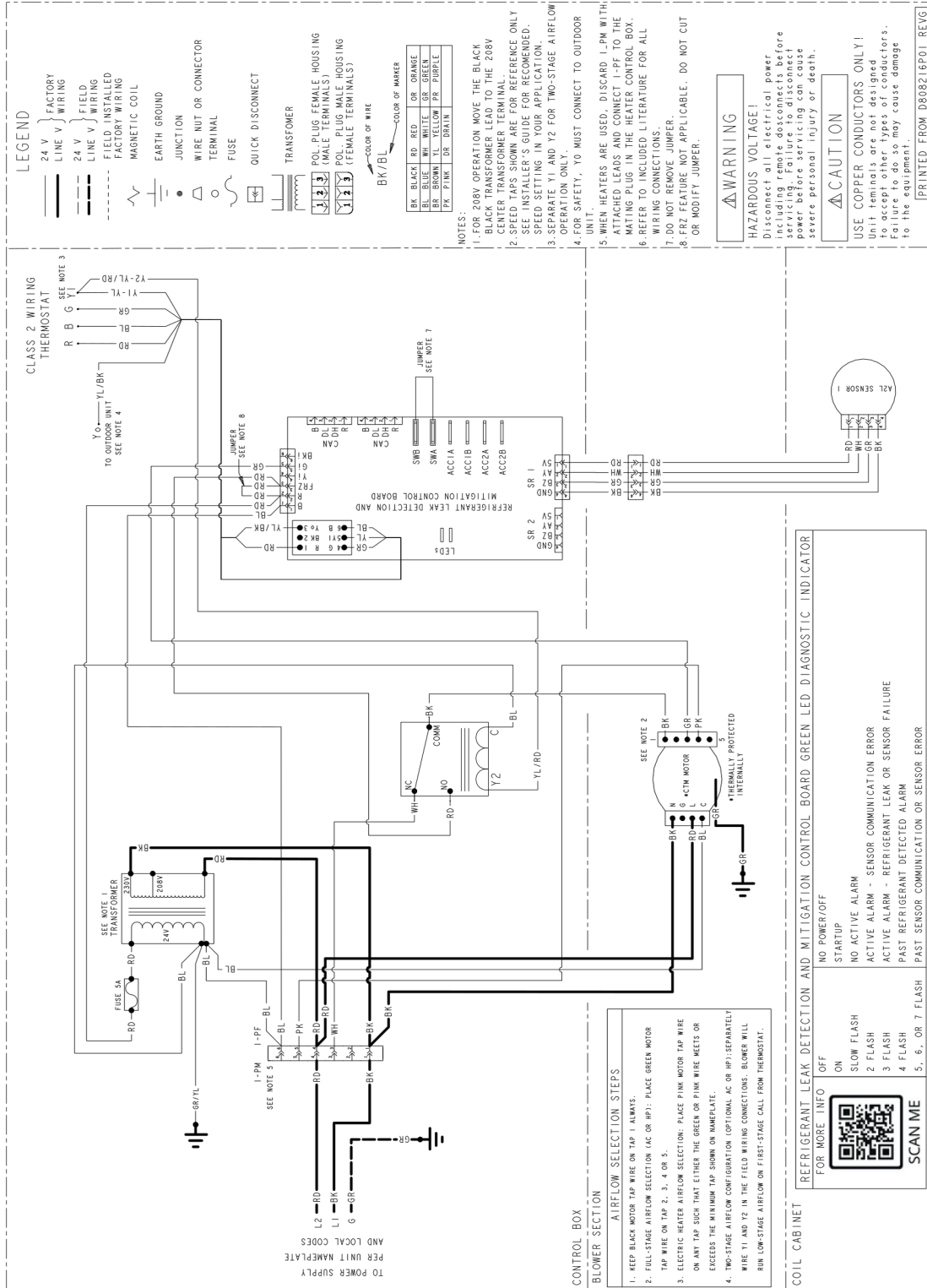

Note: For refrigerant leak detection and mitigation control board diagnostic flash codes, see Table 3, p. 13

Refrigerant Leak Detection System

For all tables contained in this section of the manual, the refrigerant charge is the total system charge which is marked on the system according to the instructions provided by the manufacturer of the outdoor unit.

⚠ WARNING
Risk of Fire — Flammable Refrigerant!
 Failure to follow instructions below could result in death or serious injury, and equipment damage.

- To be repaired only by trained service personnel.
- Do not puncture refrigerant tubing.
- Dispose of properly in accordance with federal or local regulations.

⚠ WARNING
Leak Detection System Installed!
 Failure to follow instructions below could result in death or serious injury or equipment damage. The unit is equipped with electrically powered safety measures and must be powered at all times after installation, except during servicing, to detect any leak.

To ensure safety of the building occupants, the air handler is equipped with a refrigerant leak detection system. The system is comprised of a refrigerant sensor and a mitigation control board. The system automatically detects leaks in the indoor coil and initiates actions to mitigate the risk of ignition of the leaked refrigerant, including:

- Turning on the blower of the indoor unit to dilute leaked refrigerant;

- Fully opening any zoning dampers, when applicable;
- Turning off the compressor of the outdoor unit;
- De-energizing potential sources of ignition connected to the system;
- Energizing an audible alarm, if so equipped.

Examples of potential ignition sources that are de-energized include electronic cleaners.

⚠ WARNING
Risk of Fire!
 Failure to follow instructions below could cause a fire which could result in death, serious injury, and equipment damage. Relocate the refrigerant sensor if installing the unit in any other orientation other than upflow.

Refrigerant sensors for refrigerant leak detection systems shall only be replaced as specified by the manufacturer.

Minimum Conditioned Space

The installer must verify that the total space conditioned by the system is large enough to safely dilute any leaked refrigerant in the event of a refrigerant leak of the indoor coil.

The minimum space conditioned by the appliance shall be according to [Table 2, p. 12](#). The conditioned space includes any parts of the space connected via an air duct system. The altitude of installation is the altitude above sea level of the site where the equipment is installed.

Table 2. Minimum space conditioned by the appliance

Charge (lb)	Altitude (ft)								
	sea level-2,000	2,001-4,000	4,001-6,000	6,001-8,000	8,001-10,000	10,001-12,000	12,001-14,000	14,001-15,000	above 15,000
	Minimum Conditioned Space (ft²)								
4	63	66	70	74	79	85	91	94	98
5	79	83	88	93	99	106	113	118	122
6	95	100	105	112	119	127	136	141	147
7	110	116	123	130	138	148	159	165	171
8	126	133	140	149	158	169	181	188	196
9	142	149	158	167	178	190	204	212	220
10	158	166	175	186	198	211	227	235	245
11	173	183	193	205	218	232	249	259	269
12	189	199	211	223	237	254	272	282	294
13	205	216	228	242	257	275	295	306	318
14	221	232	246	260	277	296	318	330	343
15	236	249	263	279	297	317	340	353	367
16	252	266	281	298	317	338	363	377	392
17	268	282	298	316	336	359	386	400	416
18	284	299	316	335	356	380	408	424	440
19	299	315	333	353	376	402	431	447	465
20	315	332	351	372	396	423	454	471	489

Airflow Adjustment

Note: All 5TEM4 model air handlers have been factory configured to provide sufficient airflow to dilute leaked refrigerant.

Verification of Mitigation Actions

After installation, the installer must verify that the refrigerant leak detection system actuates all mitigating actions listed above.

The test can be initiated by shorting the two test pins on the header of the mitigation control board inside of the unit. The mitigating actions will continue for approximately 5 minutes. See [Figure 3, p. 13](#) below.

Figure 3. Mitigation control board

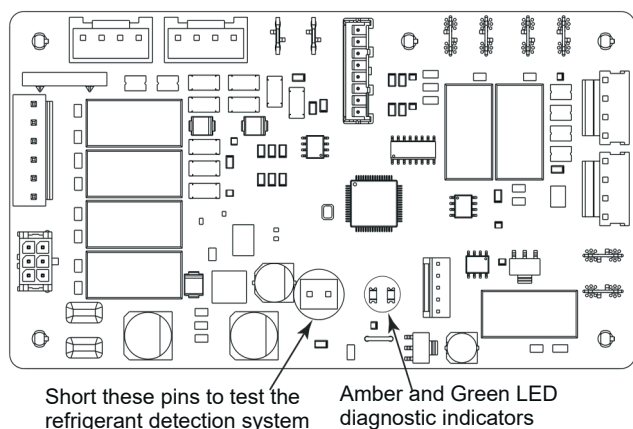

If any of the mitigating actions are not actuated by the system during the test, please check the following:

- All field wiring connections should be checked against the diagrams in the “[Field Wiring Diagrams](#),” p. 19 section of this manual.
- The diagnostic indicators on the mitigation control board should be checked against the diagnostic codes given in below.
- Scan the QR code below for more information on field troubleshooting of the refrigerant leak detection system.

Figure 4. QR code



Table 3. MCB diagnostic code table

For Software V07.1 and earlier

Condition	Green LED
Idle or Off	Off
Startup	On
No Active Alarm	Slow Flash
Active Alarm (Refrigerant Leak, Sensor Communication Error, or Sensor Error)	3 Flash
Past Refrigerant Detected Alarm	4 Flash
Past Sensor Communication Error	5 Flash
Past Sensor Error	6 Flash

For Software V9.1 and later

Condition	Green LED
No Power/Off	Off
Startup	On
Normal Operation	Slow Flash
Active Alarm - Sensor Communication Error	2 Flash
Active Alarm - Refrigerant Leak or Sensor Failure	3 Flash
Past Refrigerant Detected Alarm	4 Flash
Past Sensor Communication or Sensor Error	5, 6, or 7 Flash

Notes:

- *Amber LED diagnostic indicator should always be “ON”.*
- *Software version is printed on label on control board.*

Installation Instructions

1. Unpacking

Carefully unpack the unit and inspect the contents for damage. If any damage is found at the time of delivery, proper notification and claims should be made with the carrier.

Check the rating plate to assure model number and voltage, plus any kits match with what you ordered. The manufacturer should be notified within 5 days of any discrepancy or parts shortage.

2. Location

The air handler should be centrally located and may be installed in a closet, alcove, utility room, basement, crawl space or attic. Minimum clearances must be met.

Important: *The downflow sub-base may be required with electric heat applications. See minimum clearance table.*

Equipment shall be installed in such a way which reduces the likelihood of ignition of leaked refrigerant.

⚠ WARNING

Risk of Fire!

Failure to follow instructions below could cause a fire which could result in death, serious injury, and equipment damage.

Confirm the following requirements apply to the room where the air handler is installed.

- **All combustion appliances located in the same room that have continuous pilot lights must be equipped with an effective flame arrest.**
- **All indoor field-made joints of the field piping must be checked for refrigerant leaks after charging using an electronic leak detector calibrated for R-454B with sensitivity of 5 grams per year or better.**
- **The room must be constructed to avoid stagnation or fire hazard in the event of a refrigerant leak.**

The unit should be installed in a level position to ensure proper condensation drainage. Up to an additional 1/4-in. rise over the width or depth of the unit is allowed to create additional sloping towards the drain. Unit must be positioned between level and 1/4-in. rise, sloping toward the drain connections.

When the unit is installed in a closet or utility room, the room should be large enough, and have an opening to allow replacement of the unit. All servicing is done from the front and a clearance of 21-in. is needed for service unless the closet door aligns with the front of the air handler.

If you are installing the unit in an unconditioned space such as an attic or crawl space, you must ensure that the area provides sufficient air circulation to prevent moisture collection on the cabinet during high dew point conditions. A drain pan must be installed under the

entire unit when it is installed in or above a finished ceiling or in an unconditioned space.

3. Duct Work

⚠ WARNING

Risk of Fire!

Failure to follow the safety precautions could result in serious injury, death, or property damage.

Only approved auxiliary devices listed in this manual and declared suitable with the refrigerant must be installed in the connecting ductwork. Devices that may be potential ignition sources, such as hot surfaces or electric switching devices, must not be installed unless approved by the manufacturer or declared suitable with the refrigerant used.

The duct work should be installed in accordance with the NFPA No. 90A "Installation of Air Conditioning and Ventilating systems" and No. 90B "Residential Type Warm Air Heating and Air Conditioning Installation."

The duct work should be insulated in accordance with the applicable requirements for the particular installation as required by HUD, FHA, VA the applicable building code, local utility or other governing body.

Condensate Drain

4. The unit is supplied with primary and auxiliary condensate drains that have 3/4-in. NPT connections. The primary drain must be trapped outside the unit and piped in accordance with applicable building codes.

The figure shows the operation of a properly designed trap under normal operating conditions when the blower is running and the condensate is draining. Note the difference in height of the water column must at least equal the normal negative static pressure existing during operation between the cooling coil and blower. It is advisable to have the difference in water column height somewhat greater than the normal maximum operating static to allow for greater static caused by dirty filters or for the bounce of the water column on start up.

Figure 5. Condensate drain

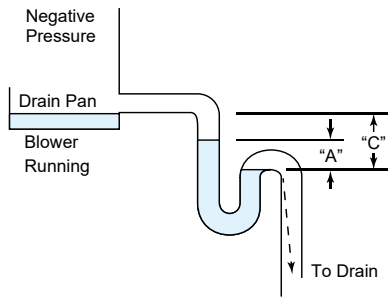

Proper operation of condensate trap under normal operating conditions.

"A" height of water column equals negative static pressure existing in system.
 "C" dimension should at least equal two times the maximum negative static pressure that can occur in system.

Do not reduce the drain line size less than the connection size on the drain pan. Condensate should be piped to an open drain or to the outside. All drains must pitch downward away from the unit a minimum of 1/4-in. per foot of line to ensure proper drainage.

Important:

- If cleanout Tee is used, stand pipe must be sealed/capped.
- If a vent Tee is used, it must be downstream from the trap.

Figure 6. Condensate drain

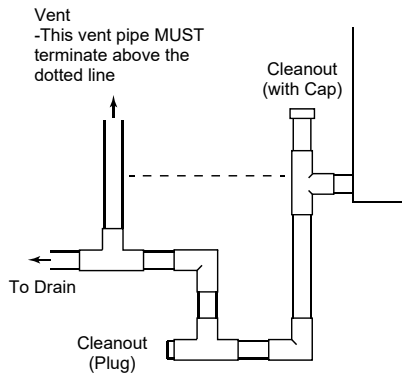

Insulate the primary drain line to prevent sweating where dew point temperatures may be met. (Insulation is optional depending on climate and application needs.)

5. Refrigerant Piping

Pipe-work including piping material, pipe routing, and installation shall include protection from physical damage in operation and service, and be in compliance with national and local codes and standards. All field joints shall be accessible for inspection prior to being covered or enclosed.

There is a holding charge of dry air in the indoor coil that will be evacuated when the sealing plugs are removed.

To protect the TXV, remove the TXV bulb from the tubing inside the unit before brazing the line set connections. Painted areas of the unit must be shielded during brazing to protect the finish.

After brazing, replace the TXV bulb and insulate it using the provided adhesive-backed insulation.

Note: For optimal performance, the TXV bulb can be located and insulated on the vapor line outside the unit. Pass the bulb and line through an opening in the line set panel. Place the bulb at the 10 or 2 o'clock position on the line, relative to the floor.

Figure 7. TXV sensing bulb

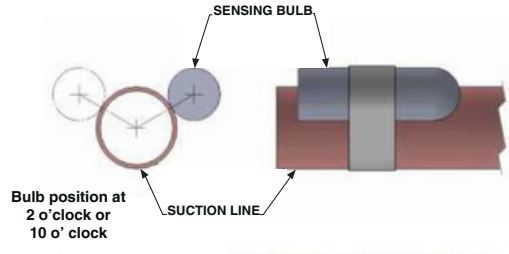

The two flammable refrigerant red warning tags on the line set connections should be removed prior to brazing and replaced once brazing is complete.

After completion of field piping for split systems, the field pipework shall be pressure tested with nitrogen and then vacuum tested prior to refrigerant charging, according to the following requirements:

Pressure test:

- Using dry nitrogen, pressurize the field piping and indoor coil to the lower of the maximum operating pressures listed on the name plates of the indoor and outdoor units (likely 600 psi).

Figure 8. Maximum operating pressure

600 PSIG

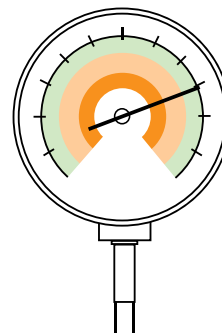

Installation Instructions

- The test pressure after removal of the pressure source shall be maintained for at least one (1) hour with no decrease of pressure indicated by the test gauge, with the test gauge resolution not exceeding 30 psi.
- Check for leaks by using a soapy solution at each field-made joint.

Figure 9. Leak check

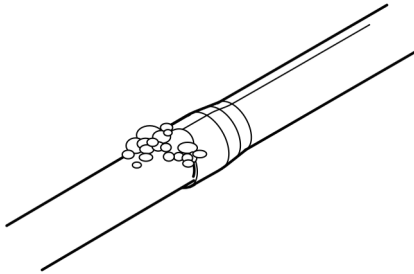

Note: Remove nitrogen pressure and repair any leaks before continuing.

Vacuum test:

Important: Do not open the service valves until the refrigerant lines and indoor coil leak check and evacuation are complete.

- Evacuate until the micron gauge reads no higher than 350 microns, then close off the valve to the vacuum pump.

Figure 10. Micron gauge

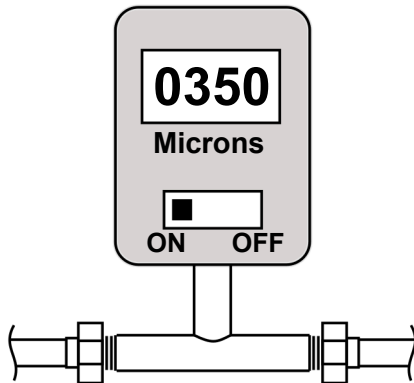

- Observe the micron gauge. Evacuation is complete if the micron gauge does not rise above 500 microns in one (1) minute and 1500 microns in ten (10) minutes.
- Once evacuation is complete, blank off the vacuum pump and micron gauge, and close the valve on the manifold gauge set.

All procedures for charging the system with refrigerant shall be according to the instructions provided by the manufacturer of the outdoor unit.

Important: Under no circumstances shall potential sources of ignition be used in the searching for or detection of refrigerant leaks.

After charging the system, all indoor field-made joints of the field piping shall be checked for refrigerant leaks using an electronic leak detector calibrated for R-454B having a sensitivity of 5 grams per year or better.

6. Metering Device

All units are shipped and installed with an internally-checked, non-bleed TXV designed for air conditioning or heat pump operation. Some outdoor models may require a start assist kit. See outdoor unit for more information.

7. Blower

This unit is supplied with a multi-speed motor with a direct drive blower wheel which can obtain various air flows. The unit is shipped with factory set cooling and heating air flows. Performance tables are available for additional airflow settings. Disconnect all power to the unit before making any adjustments to the airflow settings. Be sure to check the air flow and the temperature drop across the evaporator coil to ensure sufficient air flow.

Note: For optimal performance, seal the seams of the front panels using an appropriate tape to reduce air leakage.

8. Airflow Adjustment

Set indoor airflow as follows:

Full-stage airflow selection using motor taps, AC or HP:

- a. Retain black wire on tap 1 at all times.
- b. Install green wire on tap 2, 3, 4, or 5. See the "Airflow Performance Data," p. 22 for airflow settings.
- c. If electric heater is configured, install the pink wire on any tap. The green or pink wire tap selection must meet or exceed the minimum tap selection shown in "Minimum Airflow CFM," p. 28.

Two-stage airflow configuration (optional) using low-voltage wiring, AC or HP:

Separate Y1 and Y2 wires at the field wiring pigtail connections.

Independently wire Y1 and Y2 to compatible two-stage thermostat. See "Field Wiring Diagrams," p. 19 for wiring instructions.

First-stage airflow is approximately 75% of full-stage airflow setting.

Notes:

- a. *The blower motor is programmed to run the low-stage of the two-stage configuration when Y2 is not energized. (No additional motor tap adjustment is necessary.)*
- b. *The system is configured to consistently provide full-stage airflow when the electric heater is operating, even when the unit is configured for two stages of airflow.*

9. Wiring

Consult all schematic and pictorial wiring diagrams of this unit and the outdoor equipment to determine compatibility of wiring connections and to determine specific requirements.

All field wiring to the air handler should be installed in accordance with the latest edition of the National Electric Code NFPA No. 70 and any local codes. Check rating plates on unit for rated volts, minimum circuit ampacity and maximum over current protection. Supply circuit power wiring must be 75 degree C (167 degree F) minimum copper conductors only. Copper supply wires shall be sized to the National Electric Code or local code requirements, whichever is more stringent.

To allow disconnection of the air handler from the power supply, a disconnection from the supply mains having a contact separation in all poles must be incorporated into the fixed wiring in accordance with national, state, and local codes.

The unit is shipped wired for 230/240 Volt AC 60 HZ 1 Phase Operation. If the unit is to be operated at 208 VAC 60HZ, follow the instructions on the indoor unit wiring diagram to change the low voltage transformer to 208 VAC operation (Ensure unit is properly grounded).

Class 2 low voltage control wiring should not be run in conduit with power wiring and must be separated from power wiring unless class 1 wire with proper voltage rating is used.

Low voltage control wiring should be 18 Awg, color coded (105 degree C minimum). For lengths longer than 100ft., 16 Awg wire should be used. Make certain that separation of control wiring and power wiring has been maintained.

10. Air Filter

To protect the coil, blower and other internal parts from excessive dirt and dust an air filter must be installed before air enters the evaporator coil. A remote filter must be installed. Consult the filter manufacturer for proper sizing and maximum velocity requirements.

Important: *Air filters shall meet the test requirements in UL 900.*

11. Thermostat

Select a single or two-stage thermostat that is commonly used with HP or AC heating/cooling with

electric heat. The thermostat will energize the fan on a demand for heat or cool.

Install the thermostat on an inside wall, away from drafts, lights or other heat sources in a location that has sufficient air circulation from other rooms being controlled by the thermostat.

12. Sequence of Operation Cooling (Cooling only)

When the thermostat calls for cooling, the circuits from R to G is completed. The green wire to the blower motor is energized directly by the 24VAC signal from the thermostat.

The circuit from R to Y is also complete energizing the compressor contactor of the outdoor unit. The contactor will close and start the compressor and condenser fan motor.

Completion of the circuit from R to Y (or R to Y2, if indoor is configured for two-stage airflow) energizes the coil of the relay on the indoor unit. The relay energizes the black wire to the blower motor and activates high-stage airflow.

Cooling (heat pump)

When the thermostat calls for cooling, the circuits from R to G is completed. The green wire to the blower motor is energized directly by the 24VAC signal from the thermostat.

The circuit from R to Y is also complete energizing the compressor contactor of the outdoor unit. The contactor will close and start the compressor and condenser fan motor.

Completion of the circuit from R to Y (or R to Y2, if indoor is configured for two-stage airflow) energizes the coil of the relay on the indoor unit. The relay energizes the black wire to the blower motor and activates high-stage airflow.

Circuit R to O energizes the reversing valve to the cooling position.

Heating (heat pump)

When the thermostat calls for cooling, the circuits from R to G is completed. The green wire to the blower motor is energized directly by the 24VAC signal from the thermostat.

The circuit from R to Y is also complete energizing the compressor contactor of the outdoor unit. The contactor will close and start the compressor and condenser fan motor.

Completion of the circuit from R to Y (or R to Y2, if indoor is configured for two-stage airflow) energizes the coil of the relay on the indoor unit. The relay energizes the black wire to the blower motor and activates high-stage airflow.

In the heating mode, the reversing valve of the outdoor unit is not energized.

Installation Instructions

If the indoor temperature continues to fall, the R to W circuit is completed energizing the electric heat contactor(s).

Heating (electric heat only)

Note: *The thermostat must be setup to bring the blower on when the electric heat is energized.*

When the thermostat calls for heating, the circuit from R to G is completed and the blower motor is energized directly by the 24VAC signal from the thermostat.

Completing the circuit from R to W (or R to W1 if configured for two-stages of electric heat) energizes the black wire to the blower motor and activates high-stage airflow.

Completing the circuit from R to W2 directly energizes the blower motor by the 24VAC signal from the thermostat.

Completing the circuit from R to W energizes the heating contactor(s).

Defrost

Supplemental heat during defrost can be provided by connecting the X2 (black) wire from the outdoor unit to W1 or W2 at the indoor unit. This will prevent cold air from being discharged from the indoor unit during defrost.

13. Operational and Checkout Procedures

To ensure proper function of the Refrigerant Leak Detection System, all procedures in the "[Refrigerant Leak Detection System](#)," p. 12 section of this manual must be verified.

To obtain proper performance, all units must be operated and charge adjustments made in accordance with procedures found in the Service Facts document of the outdoor unit.

After installation has been completed, it is recommended that the entire system be checked against the checkout list located at the back of this document. See "[Checkout Procedures](#)," p. 39.

14. Maintenance

The system air filter(s) should be inspected, cleaned or replaced at least monthly. Make certain that the access panels are replaced and secured properly before placing the unit back in operation. This product is designed for dependable service; however, periodic maintenance should be scheduled and conducted by trained professional service personnel. This service should be conducted at least annually, and should include testing and inspection of electrical and refrigerant components. The heat transfer surface should be cleaned. The blower motor is permanently lubricated for normal operating conditions.

Field Wiring Diagrams

Figure 11. Single stage, cooling only

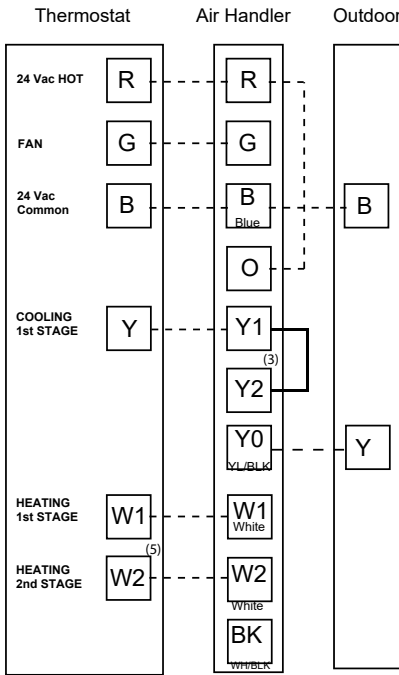
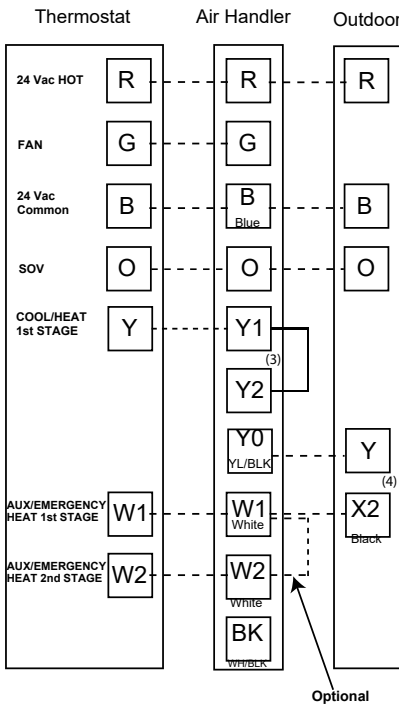

Figure 12. Single stage, HP



Field Wiring Diagrams

Figure 13. 2 Stage indoor airflow, cooling only

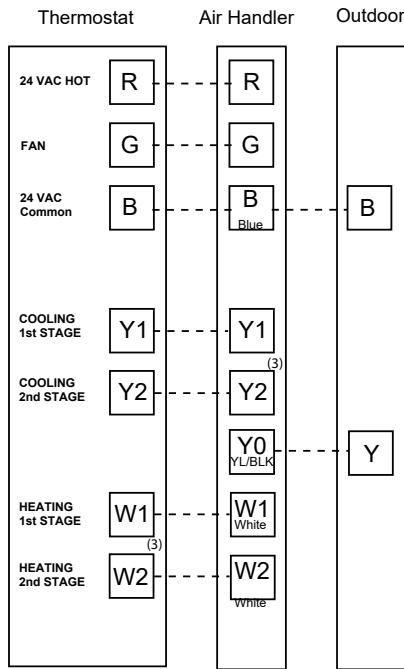
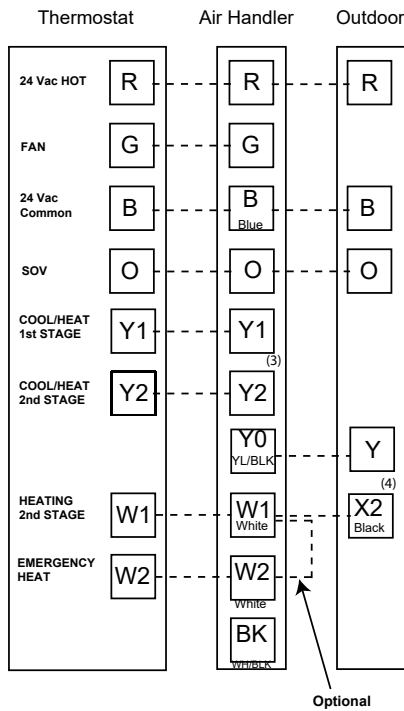

Figure 14. 2 Stage indoor airflow, HP



Notes:

1. Units with pigtails require wirenuts for connections.
2. Cap all unused wires.
3. In AC systems for multiple stages of electric heat, jumper W1 and W2 together if comfort control has only one stage of heat.
4. X2 is only needed if not using certain Trane or American Standard thermostats.

- ACC1andACC2accessoryconnections. Usewhen connecting an accessory to the air handler that could be considered a source of ignition (ex. electronic air cleaner).
- Aoa/Aobaudiblealarmconnections. Usewhen configuring an audible alarm on the refrigerant detection system of the air handler.

ACC1, ACC2, and Aoa/Aob are dry contacts and need source voltage provided from either the accessory or the unit's control wiring.

Connect using field-supplied 3/16-inch (Aoa/Aob) or 1/4-inch (ACC1, ACC2) female spade connections.

External Switches and Accessories

The following optional connections are available on the mitigation control board (see connection diagrams [Figure 15, p. 21](#)):

Figure 15.

Accessories diagram



SCAN ME

Scan QR code to view instructional videos on field wiring for CleanEffects or AccuClean electronic air cleaners.

Electronic Air Cleaner, typical

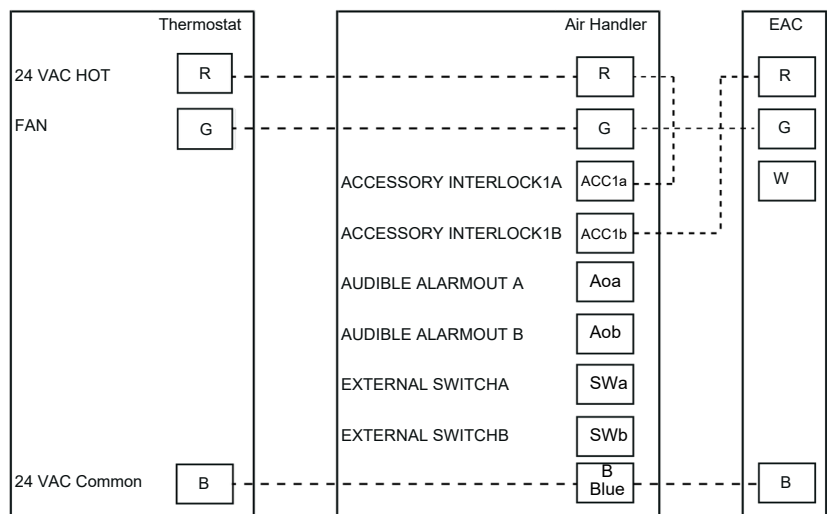

24VAC Audible Alarm, typical

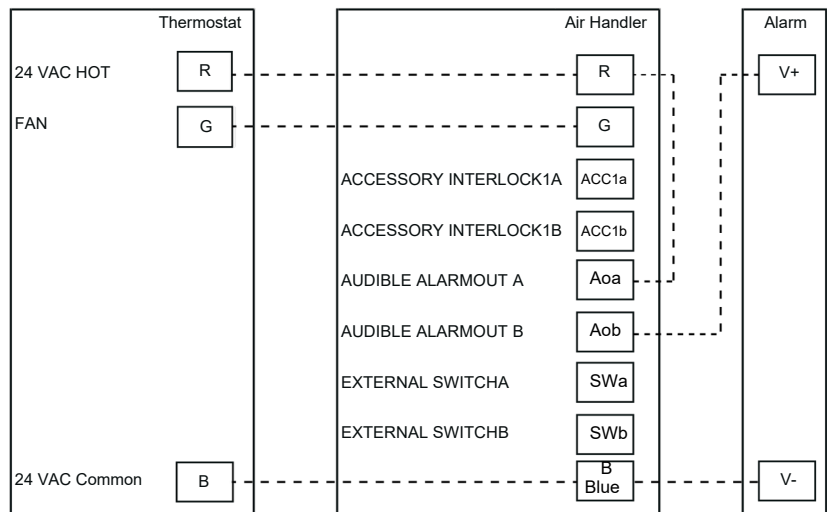

Performance and Electrical Data

Airflow Performance Data

Table 4. Model – 5TEM4B02AC21SA

External Static (in w.g)	Airflow			
	Speed Taps: 208-230 Volts			
	Tap2	Tap3(a)	Tap4	Tap5
0.1	874	978	1045	1134
0.2	824	934	1002	1096
0.3	746	881	955	1056
0.4	676	813	891	1009
0.5	606	746	828	943
0.6	551	681	762	888
0.7	481	627	702	830
0.8	404	578	653	771
0.9	328	519	606	722

Note: In horizontal and downflow applications, airflow should be limited to 1000 CFM due to condensate blowoff.

^(a) Factory setting.

Table 5. Model – 5TEM4B03AC31SA

External Static (in w.g)	Airflow			
	Speed Taps: 208-230 Volts			
	Tap2	Tap3(a)	Tap4	Tap5
0.1	886	1027	1094	1196
0.2	844	989	1059	1164
0.3	791	947	1020	1130
0.4	719	896	978	1094
0.5	660	837	926	1053
0.6	584	778	864	1006
0.7	517	723	813	948
0.8	460	650	753	897
0.9	378	594	694	850

Note: In horizontal and downflow applications, airflow should be limited to 1000 CFM due to condensate blowoff.

^(a) Factory setting.

Table 6. Model – 5TEM4B04AC31SA

External Static (in w.g)	Airflow			
	Speed Taps: 208-230 Volts			
	Tap2	Tap3(a)	Tap4	Tap5
0.1	1183	1267	1347	1390
0.2	1141	1230	1310	1346
0.3	1101	1189	1273	1309
0.4	1053	1149	1237	1275
0.5	1004	1105	1196	1236
0.6	957	1058	1155	1196
0.7	916	1016	1111	1153
0.8	870	974	1072	1113
0.9	828	935	1034	1073

Note: In horizontal and downflow applications, airflow should be limited to 1200 CFM due to condensate blowoff.

^(a) Factory setting.

Table 7. Model – 5TEM4D05AC41SA

External Static (in w.g)	Airflow			
	Speed Taps: 208-230 Volts			
	Tap2	Tap3(a)	Tap4	Tap5
0.1	1266	1340	1425	1577
0.2	1214	1286	1384	1535
0.3	1163	1242	1335	1494
0.4	1114	1195	1290	1452
0.5	1057	1144	1246	1410
0.6	996	1087	1187	1367
0.7	931	1026	1128	1319
0.8	853	961	1071	1268
0.9	779	889	1005	1211

^(a) Factory setting.

Table 8. Model – 5TEM4D06AC41SA and 5TEM4D06AC41SB

External Static (in w.g)	Airflow			
	Speed TapAirflows: 208-230 Volts			
	Tap2	Tap3(a)	Tap4	Tap5
0.1	1550	1592	1804	1971
0.2	1511	1550	1767	1939
0.3	1470	1510	1734	1907
0.4	1426	1469	1697	1867
0.5	1379	1424	1656	1839
0.6	1324	1381	1615	1804
0.7	1278	1338	1575	1766
0.8	1229	1292	1536	1722
0.9	1173	1241	1492	1691

Note: In horizontal and downflow applications, airflow should be limited to 1700 CFM due to condensate blowoff.

^(a) Factory setting.

Table 9. Model – 5TEM4D07AC51SA

External Static (in w.g)	Airflow			
	Speed Taps: 208-230 Volts			
	Tap2	Tap3(a)	Tap4	Tap5
0.1	1574	1648	1781	1935
0.2	1538	1608	1749	1900
0.3	1502	1577	1715	1872
0.4	1466	1542	1685	1842
0.5	1425	1506	1651	1814
0.6	1374	1466	1616	1784
0.7	1328	1423	1576	1749
0.8	1280	1377	1531	1712
0.9	1227	1329	1489	1674

Note: In horizontal and downflow applications, airflow should be limited to 1800 CFM due to condensate blowoff.

^(a) Factory setting.

Performance and Electrical Data

Notes:

- Tap 1 is not an airflow selection. Black wire must always be on Tap 1.
- Values are with wet coil, no filter, and no heaters.
- CFM correction for dry coil = add 3%.
- First-stage airflow is approximately 75% of full-stage airflow setting.

Electrical Data

Table 10. Model – 5TEM4B02AC21SA

Heater Model No.	No. of Circuits/ Phases	240 Volt					208 Volt				
		Capacity		Heater Ampsper Circuit	Minimum Circuit Ampacity	Maximum Overload Protection	Capacity		Heater Ampsper Circuit	Minimum Circuit Ampacity	Maximum Overload Protection
		kW	BTUH				kW	BTUH			
No Heater	—	—	—	2.6(a)	3	15	—	—	2.6(a)	3	15
BAYHTR1504BRK BAYHTR1504LUG	1/1	3.8	13100	16.0	23	25	2.9	9800	13.8	21	25
BAYHTR1505BRK BAYHTR1505LUG	1/1	4.8	16400	20.0	28	30	3.6	12300	17.3	25	25
BAYHTR1508BRK BAYHTR1508LUG	1/1	7.7	26200	32.0	43	45	5.8	19700	27.7	38	40
BAYHTR1510BRK BAYHTR1510LUG	1/1	9.6	32800	40.0	53	60	7.2	24600	34.6	47	50
BAYHTR3510LUG	1/3	9.6	32800	23.1	32	35	7.2	24600	20.0	28	30

(a) Motor Amps.

Table 11. Model – 5TEM4B03AC31SA

Heater Model No.	No. of Circuits/ Phases	240 Volt					208 Volt				
		Capacity		Heater Ampsper Circuit	Minimum Circuit Ampacity	Maximum Overload Protection	Capacity		Heater Ampsper Circuit	Minimum Circuit Ampacity	Maximum Overload Protection
		kW	BTUH				kW	BTUH			
No Heater	—	—	—	3.9(a)	5	15	—	—	3.9(a)	5	15
BAYHTR1504BRK BAYHTR1504LUG	1/1	3.8	13100	16.0	25	25	2.9	9800	13.8	22	25
BAYHTR1505BRK BAYHTR1505LUG	1/1	4.8	16400	20.0	30	30	3.6	12300	17.3	27	30
BAYHTR1508BRK BAYHTR1508LUG	1/1	7.7	26200	32.0	45	45	5.8	19700	27.7	39	40
BAYHTR1510BRK BAYHTR1510LUG	1/1	9.6	32800	40.0	55	60	7.2	24600	34.6	48	50
BAYHTR1517BRK- Circuit 1(b)	2/1	9.6	32800	40.0	55	60	7.2	24600	34.6	48	50
BAYHTR1517BRK- Circuit 2		4.8	16400	20.0	25	25	3.6	12300	17.3	22	25
BAYHTR3510LUG	1/3	9.6	32800	23.1	33	35	7.2	24600	20.0	29	30
BAYHTR3517LUG	1/3	14.4	49100	34.6	48	50	10.8	36900	30.0	42	45

(a) Motor Amps.

(b) MCA and MOP for circuit 1 contains the motor amps.

Table 12. Models – 5TEM4B04AC31SA

Heater Model No.	No. of Circuits/ Phases	240 Volt					208 Volt				
		Capacity		Heater Ampsper Circuit	Minimum Circuit Ampacity	Maximum Overload Protection	Capacity		Heater Ampsper Circuit	Minimum Circuit Ampacity	Maximum Overload Protection
		kW	BTUH				kW	BTUH			
No Heater	—	—	—	3.9(a)	5	15	—	—	3.9(a)	5	15
BAYHTR1504BRK BAYHTR1504LUG	1/1	3.84	13100	16.0	25	25	2.88	9800	13.8	22	25

Table 12. Models – 5TEM4B04AC31SA (continued)

Heater Model No.	No. of Circuits/ Phases	240 Volt					208 Volt				
		Capacity		Heater Amps per Circuit	Minimum Circuit Ampacity	Maximum Overload Protection	Capacity		Heater Amps per Circuit	Minimum Circuit Ampacity	Maximum Overload Protection
		kW	BTUH				kW	BTUH			
BAYHTR1505BRK BAYHTR1505LUG	1/1	4.80	16400	20.0	30	30	3.60	12300	17.3	27	30
BAYHTR1508BRK BAYHTR1508LUG	1/1	7.68	26200	32.0	45	45	5.76	19700	27.7	39	40
BAYHTR1510BRK BAYHTR1510LUG	1/1	9.60	32800	40.0	55	60	7.20	24600	34.6	48	50
BAYHTR1517BRK- Circuit 1(b)	2/1	9.60	32800	40.0	55	60	7.20	24600	34.6	48	50
BAYHTR1517BRK- Circuit 2		4.80	16400	20.0	25	25	3.60	12300	17.3	22	25
BAYHTR1523BRK- Circuit 1(b)	2/1	9.60	32800	40.0	55	60	7.20	24600	34.6	48	50
BAYHTR1523BRK- Circuit 2		9.60	32800	40.0	50	50	7.20	24600	34.6	43	45
BAYHTR3510LUG	1/3	9.60	32800	23.1	33	35	7.20	24600	20.0	29	30
BAYHTR3517LUG	1/3	14.40	49100	34.6	48	50	10.80	36900	30.0	42	45

(a) Motor Amps.

(b) MCA and MOP for circuit 1 contains the motor amps.

Table 13. Model – 5TEM4D05AC41SA

Heater Model No.	No. of Circuits/ Phases	240 Volt					208 Volt				
		Capacity		Heater Amps per Circuit	Minimum Circuit Ampacity	Maximum Overload Protection	Capacity		Heater Amps per Circuit	Minimum Circuit Ampacity	Maximum Overload Protection
		kW	BTUH				kW	BTUH			
No Heater	—	—	—	4.1(a)	5	15	—	—	4.1(a)	5	15
BAYHTR1504BRK BAYHTR1504LUG	1/1	3.8	13100	16.0	25	25	2.9	9800	13.8	22	25
BAYHTR1505BRK BAYHTR1505LUG	1/1	4.8	16400	20.0	30	30	3.6	12300	17.3	27	30
BAYHTR1508BRK BAYHTR1508LUG	1/1	7.7	26200	32.0	45	45	5.8	19700	27.7	40	40
BAYHTR1510BRK BAYHTR1510LUG	1/1	9.6	32800	40.0	55	60	7.2	24600	34.6	48	50
BAYHTR1517BRK- Circuit 1(b)	2/1	9.6	32800	40.0	55	60	7.2	24600	34.6	48	50
BAYHTR1517BRK- Circuit 2		4.8	16400	20.0	25	25	3.6	12300	17.3	22	25
BAYHTR1523BRK- Circuit 1(b)	2/1	9.6	32800	40.0	55	60	7.2	24600	34.6	48	50
BAYHTR1523BRK- Circuit 2		9.6	32800	40.0	50	50	7.2	24600	34.6	43	45
BAYHTR3510LUG	1/3	9.6	32800	23.1	33	35	7.2	24600	20.0	30	30
BAYHTR3517LUG	1/3	14.4	49100	34.6	48	50	10.8	36900	30.0	42	45

(a) Motor Amps.

(b) MCA and MOP for circuit 1 contains the motor amps.

Performance and Electrical Data

Table 14. Model – 5TEM4D06AC41SB

Heater Model No.	No. of Circuits/ Phases	240 Volt					208 Volt				
		Capacity		Heater Amps per Circuit	Minimum Circuit Ampacity	Maximum Overload Protection	Capacity		Heater Amps per Circuit	Minimum Circuit Ampacity	Maximum Overload Protection
		kW	BTUH				kW	BTUH			
No Heater				4.7(a)	6	15			4.7(a)	6	15
BAYHTR1504BRK BAYHTR1504LUG	1/1	3.8	13100	16.0	26	30	2.9	9800	13.8	23	25
BAYHTR1505BRK BAYHTR1505LUG BAYHTR1508BRK	1/1	4.8	16400	20.0	31	35	3.6	12300	17.3	28	30
BAYHTR1508LUG BAYHTR1510BRK	1/1	7.7	26200	32.0	46	50	5.8	19700	27.7	41	45
BAYHTR1510LUG BAYHTR1517BRK-	1/1	9.6	32800	40.0	56	60	7.2	24600	34.6	49	50
Circuit 1(b) BAYHTR1517BRK- Circuit 2	2/1	9.6	32800	40.0	56	60	7.2	24600	34.6	49	50
BAYHTR1523BRK- Circuit 1(b)		4.8	16400	20.0	25	25	3.6	12300	17.3	22	25
BAYHTR1523BRK- Circuit 2 BAYHTR1525BRK- Circuit 1(b) BAYHTR1525BRK-	2/1	9.6	32800	40.0	56	60	7.2	24600	34.6	49	50
		9.6	32800	40.0	50	50	7.2	24600	34.6	43	45
Circuit 2 BAYHTR1525BRK- Circuit 3 BAYHTR1525BRK- Circuit 4 BAYHTR3510LUG BAYHTR3517LUG	4/1	6.0	20500	25.0	37	40	4.5	15400	21.6	33	35
		6.0	20500	25.0	31	35	4.5	15400	21.6	27	30
		6.0	20500	25.0	31	35	4.5	15400	21.6	27	30
		6.0	20500	25.0	31	35	4.5	15400	21.6	27	30
	1/3	9.6	32800	23.1	34	35	7.2	24600	20.0	30	35
	1/3	14.4	49100	34.6	49	50	10.8	36900	30.0	43	45

(a) Motor Amps.

(b) MCA and MOP for circuit 1 contains the motor amps.

Table 15. Models – 5TEM4D06AC41SA and 5TEM4D07AC51SA

Heater Model No.	No. of Circuits/ Phases	240 Volt					208 Volt				
		Capacity		Heater Amps per Circuit	Minimum Circuit Ampacity	Maximum Overload Protection	Capacity		Heater Amps per Circuit	Minimum Ampacity	Maximum Overload Protection
		kW	BTUH				kW	BTUH			
No Heater	—	—	—	6.0(a)	8	15	—	—	6.0(a)	8	15
BAYHTR1504BRK BAYHTR1504LUG	1/1	3.8	13100	16.0	28	30	2.9	9800	13.8	25	25
BAYHTR1505BRK BAYHTR1505LUG	1/1	4.8	16400	20.0	33	35	3.6	12300	17.3	29	30
BAYHTR1508BRK BAYHTR1508LUG	1/1	7.7	26200	32.0	48	50	5.8	19700	27.7	42	45
BAYHTR1510BRK BAYHTR1510LUG	1/1	9.6	32800	40.0	58	60	7.2	24600	34.6	51	60

Table 15. Models – 5TEM4D06AC41SA and 5TEM4D07AC51SA (continued)

Heater Model No.	No. of Circuits/ Phases	240 Volt					208 Volt				
		Capacity		Heater Amps per Circuit	Minimum Circuit Ampacity	Maximum Overload Protection	Capacity		Heater Amps per Circuit	Minimum Ampacity	Maximum Overload Protection
		kW	BTUH				kW	BTUH			
BAYHTR1517BRK-Circuit 1(b)	2/1	9.6	32800	40.0	58	60	7.2	24600	34.6	51	60
BAYHTR1517BRK-Circuit 2		4.8	16400	20.0	25	25	3.6	12300	17.3	22	25
BAYHTR1523BRK-Circuit 1(b)	2/1	9.6	32800	40.0	58	60	7.2	24600	34.6	51	60
BAYHTR1523BRK-Circuit 2		9.6	32800	40.0	50	50	7.2	24600	34.6	43	45
BAYHTR1525BRK-Circuit 1(b)	4/1	6.0	20500	25.0	39	40	4.5	15400	21.6	35	35
BAYHTR1525BRK-Circuit 2		6.0	20500	25.0	31	35	4.5	15400	21.6	27	30
BAYHTR1525BRK-Circuit 3		6.0	20500	25.0	31	35	4.5	15400	21.6	27	30
BAYHTR1525BRK-Circuit 4		6.0	20500	25.0	31	35	4.5	15400	21.6	27	30
BAYHTR3510LUG	1/3	9.6	32800	23.1	36	40	7.2	24600	20.0	32	35
BAYHTR3517LUG	1/3	14.4	49100	34.6	50	50	10.8	36900	30.0	44	45

^(a) Motor Amps.

^(b) MCA and MOP for circuit 1 contains the motor amps.

Minimum Airflow CFM

Table 16. Model — 5TEM4B02AC21SA

Heater	Minimum Heat Speed Tap	
	WithHeatPump	WithoutHeatPump
BAYHTR1504BRK, BAYHTR1504LUG, BAYHTR1505BRK, BAYHTR1505LUG	Tap2	Tap2
BAYHTR1508BRK, BAYHTR1508LUG, BAYHTR1510BRK, BAYHTR1510LUG, BAYHTR3510LUG	Tap5	Tap5

Table 17. Model — 5TEM4B03AC31SA

Heater	Minimum Heat Speed Tap	
	WithHeatPump	WithoutHeatPump
BAYHTR1504BRK, BAYHTR1504LUG, BAYHTR1505BRK, BAYHTR1505LUG	Tap3	Tap3
BAYHTR1508BRK, BAYHTR1508LUG, BAYHTR1510BRK, BAYHTR1510LUG	Tap4	Tap3
BAYHTR1517BRK, BAYHTR3517LUG, BAYHTR3510LUG	Tap5	Tap3

Table 18. Model — 5TEM4B04AC31SA

Heater	Minimum Heat Speed Tap	
	WithHeatPump	WithoutHeatPump
BAYHTR1504BRK, BAYHTR1504LUG, BAYHTR1505BRK, BAYHTR1505LUG	Tap2	Tap2
BAYHTR1508BRK, BAYHTR1508LUG, BAYHTR1510BRK, BAYHTR1510LUG	Tap5	Tap3
BAYHTR1523BRK	Tap5	Tap3
BAYHTR1517BRK, BAYHTR3517LUG, BAYHTR3510LUG	Tap5	Tap3

Table 19. Models — 5TEM4D05AC41SA

Heater	Minimum Heat Speed Tap	
	WithHeatPump	WithoutHeatPump
BAYHTR1504BRK, BAYHTR1504LUG, BAYHTR1505BRK, BAYHTR1505LUG	Tap2	Tap2
BAYHTR1508BRK, BAYHTR1508LUG, BAYHTR1510BRK, BAYHTR1510LUG	Tap4	Tap4
BAYHTR1523BRK	Tap4	Tap3
BAYHTR1517BRK, BAYHTR3517LUG, BAYHTR3510LUG	Tap5	Tap3

Table 20. Model — 5TEM4D06AC41SA and 5TEM4D06AC41SB

Heater	Minimum Heat Speed Tap	
	WithHeatPump	WithoutHeatPump
BAYHTR1504BRK, BAYHTR1504LUG, BAYHTR1505BRK, BAYHTR1505LUG, BAYHTR1508BRK, BAYHTR1508LUG, BAYHTR1510BRK, BAYHTR1510LUG, BAYHTR3510LUG	Tap2	Tap2
BAYHTR1517BRK, BAYHTR3517LUG	Tap4	Tap4
BAYHTR1523BRK, BAYHTR1525BRK	Tap5	Tap4

Table 21. Model — 5TEM4D07AC51SA

Heater	Minimum Heat Speed Tap	
	WithHeatPump	WithoutHeatPump
BAYHTR1504BRK, BAYHTR1504LUG, BAYHTR1505BRK, BAYHTR1505LUG, BAYHTR1508BRK, BAYHTR1508LUG, BAYHTR1510BRK, BAYHTR1510LUG, BAYHTR3510LUG	Tap2	Tap2
BAYHTR1517BRK, BAYHTR3517LUG	Tap3	Tap3
BAYHTR1523BRK, BAYHTR1525BRK	Tap5	Tap3

Heater Pressure Drop Table

Table 22. Heat pressure drop

Airflow CFM	Number of Racks				Heater Racks	
	1	23	4		Heater Model	No. of Racks
	Air Pressure Drop — Inches W.G.					
1800	0.02	0.04	0.06	0.14	BAYHTR1504	1
1700	0.02	0.04	0.06	0.14	BAYHTR1505	2
1600	0.02	0.04	0.06	0.13	BAYHTR1508	2
1500	0.02	0.04	0.06	0.12	BAYHTR1510	2
1400	0.02	0.04	0.06	0.12	BAYHTR1517	3
1300	0.02	0.04	0.05	0.11	BAYHTR3510	3
1200	0.01	0.04	0.05	0.10	BAYHTR3517	3
1100	0.01	0.03	0.05	0.09	BAYHTR1523	4
1000	0.01	0.03	0.04	0.09	BAYHTR1525	4
900	0.01	0.03	0.04	0.08	—	—
800	0.01	0.03	—	—	—	—
700	0.01	0.02	—	—	—	—
600	0.01	0.02	—	—	—	—

Unit Conversion Instructions

⚠ WARNING

Risk of Fire!

Failure to follow instructions below could cause a fire which could result in death, serious injury, and equipment damage.

Relocate the refrigerant sensor if installing the unit in any other orientation other than upflow.

Horizontal Left Sensor Relocation

Important: For horizontal applications, airflow restrictions apply for condensate blow off. See “Airflow Performance Data,” p. 22 Tables in this manual.

Follow the conversion steps when installing the air handler in horizontal left configuration.

1. Remove the front panels from the air handler. The coil and line set panel do not need to be separated.
2. Remove the fasteners on both sides of the coil. Retain the coil containing brackets and screws.
3. Proceed to [Step 11](#) if using coil support brackets as shown in [Figure 18](#), p. 30. Proceed to [Step 4](#) if using coil support brackets shown in [Figure 19](#), p. 31.
4. Remove the two screws holding the center horizontal bracket and rotate out of place. Retain parts.

Figure 16. Horizontal bracket and refrigerant sensor

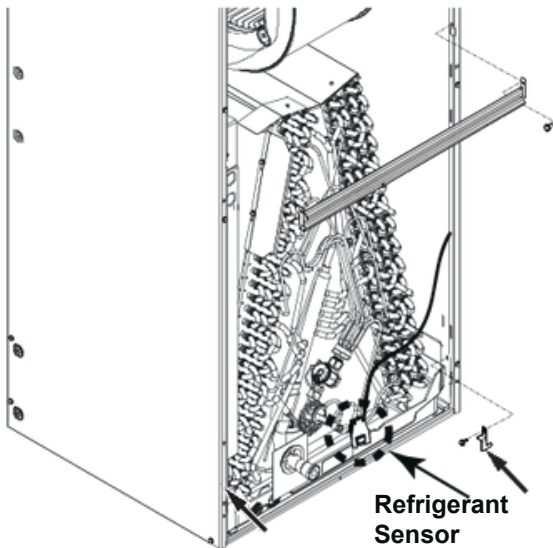

5. Pull refrigerant sensor up and away from the primary drain pan and remove it from the pan. Detach the sensor and clip from the wire harness and move it out of the way.

6. Slide the coil assembly out.

Figure 17. Coil assembly and horizontal drain pan

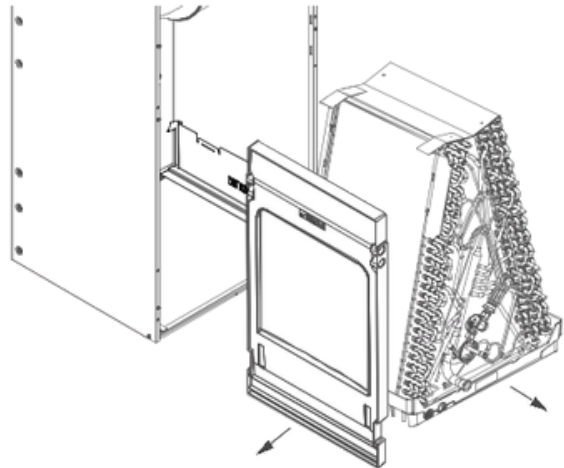

7. Bend the two tabs on the right coil support bracket. Tabs should be bent inward so they are parallel to the bottom flange.

Figure 18. Coil support brackets

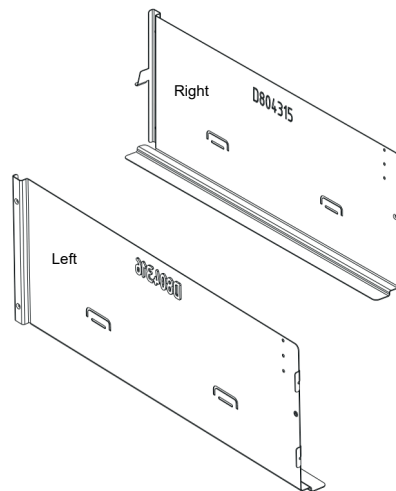
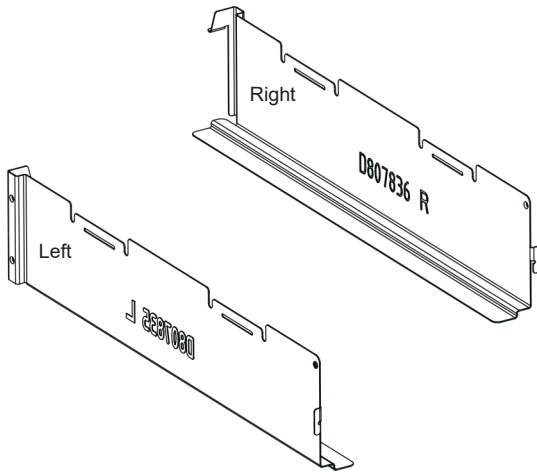

Figure 19. Coil Support Brackets with two large tabs



8. Slide the coil assembly back into the air handler cabinet.

Important: When reinstalling coil in Step 8., it is important that the coil corner locks in place under the rear tab in the side bracket to support the coil weight horizontally. There are 2 additional tabs for added support.

9. Replace the center horizontal bracket from Step 4.

10. Replace coil retaining brackets and screws from Step 2.

11. Secure sensor to secondary pan using provided clip. Sensor should be positioned close to secondary drain lines.

12. Position extra wire length in the secondary drain pan.

Figure 20. Horizontal left refrigerant sensor location

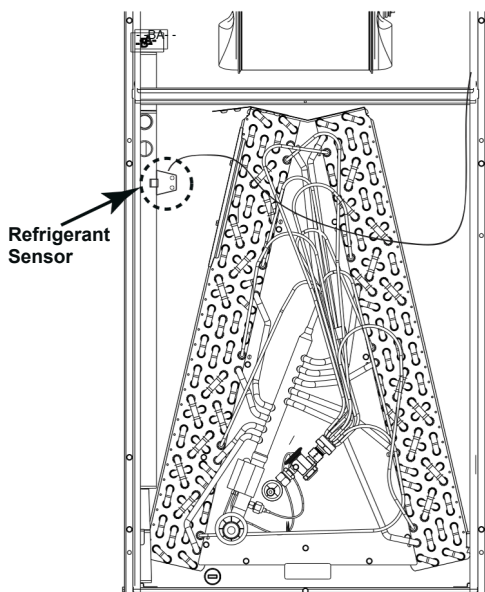

13. Replace all panels.

Downflow

Important: For downflow applications, airflow restrictions apply for condensate blow off. See "Airflow Performance Data," p. 22 Tables in this manual.

Follow the conversion steps when installing the air handler in downflow configuration.

1. Remove the front panels from the air handler. The coil and line set panel do not need to be separated.
2. Remove the fasteners on both sides of the coil.
3. Remove the two screws holding the center horizontal bracket and rotate out of place. Retain parts.

Figure 21. Horizontal bracket and refrigerant sensor

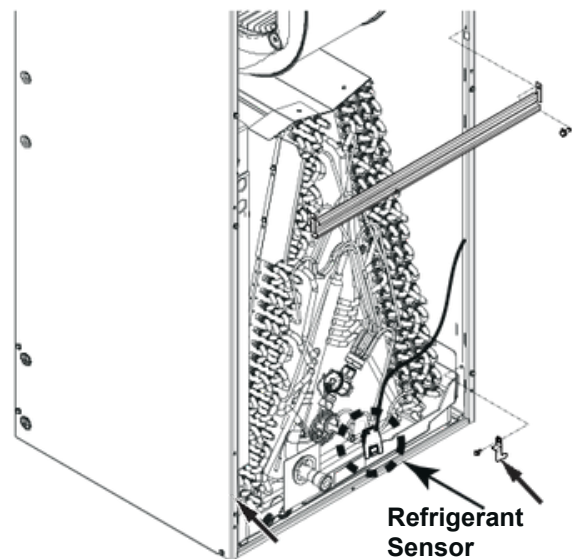

4. Pull refrigerant sensor up and away from the primary drain pan and remove it from the pan. Detach the sensor and clip from the wire harness and move it out of the way.
5. Slide the coil assembly out. Remove and discard the horizontal drain pan.

Unit Conversion Instructions

Figure 22. Coil assembly and horizontal drain pan

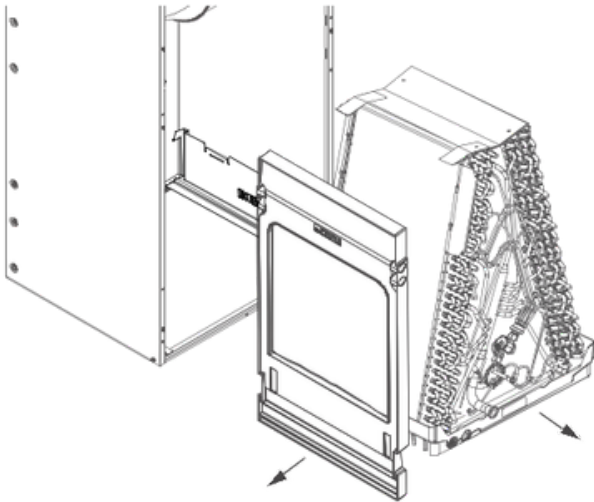

6. On both sides of the cabinet, remove the screws that hold the coil support brackets and retain for later use. Seal the holes to prevent air leakage.
7. Rotate and lift the two coil support brackets to remove from front slots in cabinet.

Figure 23. Coil support brackets

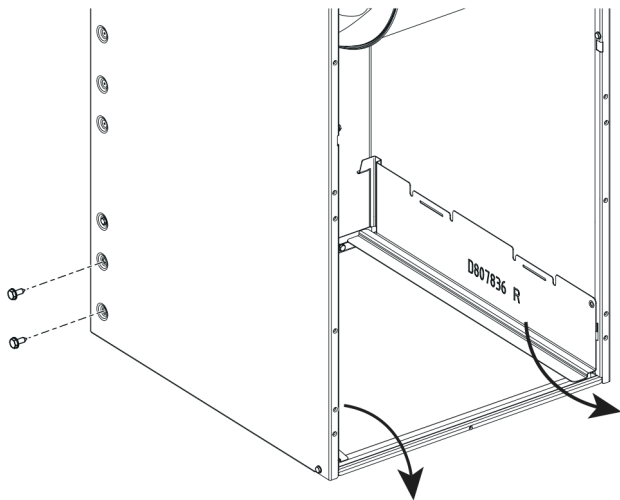

Figure 24. Coil support brackets

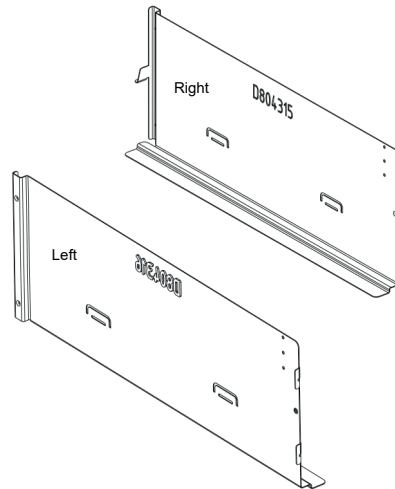
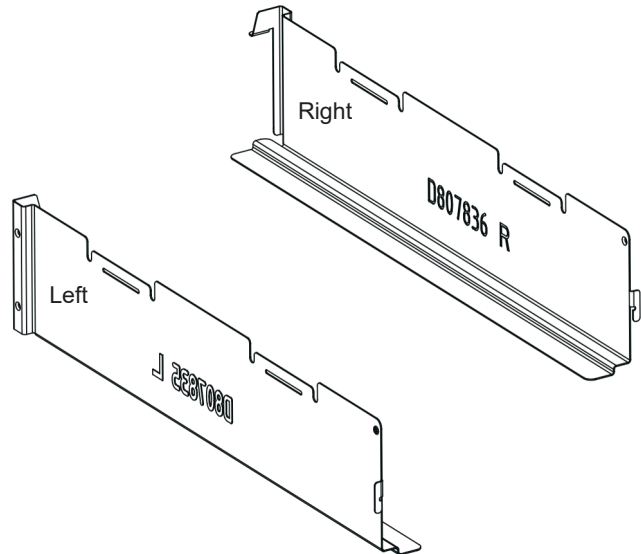
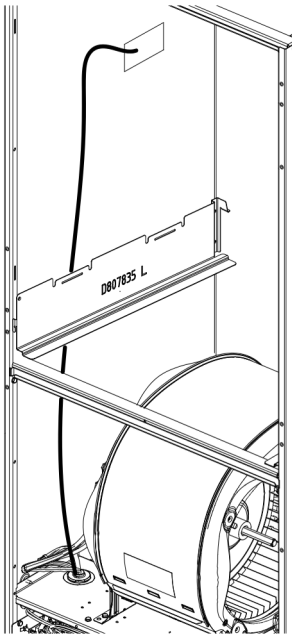

Figure 25. Coil Support Brackets with two large tabs



8. Rotate the unit into the downflow orientation.
9. Pre-drill four clearance holes in the cabinet at dimples located below the location the screws were removed for the coil support brackets. There are two holes per side. See location of holes.
10. Replace the center horizontal bracket removed in [Step 3](#). Use the screws retained from [Step 3](#) to attach.
11. Place coil support brackets into the slots and rotate into place. Push downward to lock into place. Refrigerant sensor wire harness should be routed between coil support bracket and the insulation.

Figure 26. Refrigerant sensor wire harness



12. Secure each bracket with the screws that were previously removed.

Figure 27. Coil support brackets

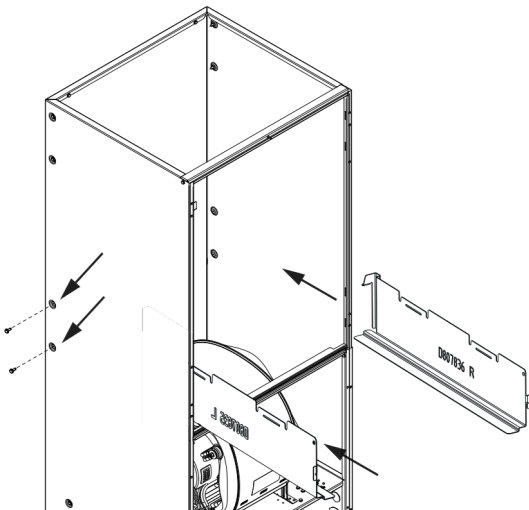

13. Slide the coil assembly back into the air handler cabinet as shown.

Figure 28. Downflow refrigerant sensor location

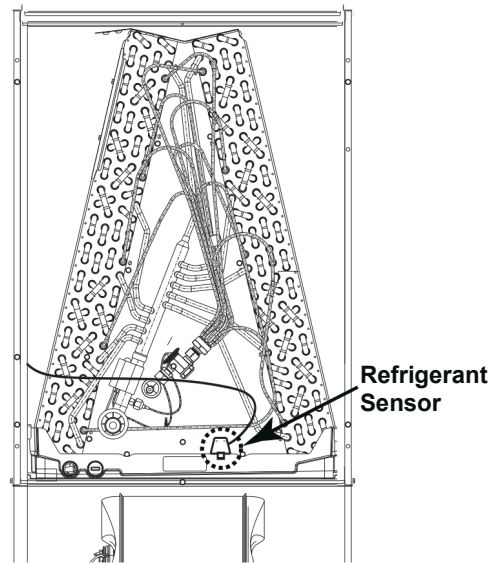

14. Clip refrigerant sensor back onto primary drain pan (as shown in figure above) and reconnect the sensor to the wire harness. Position extra wire length next to the coil.

15. Remove the appropriate knock out for the condensate piping.

Figure 29. Coil assembly

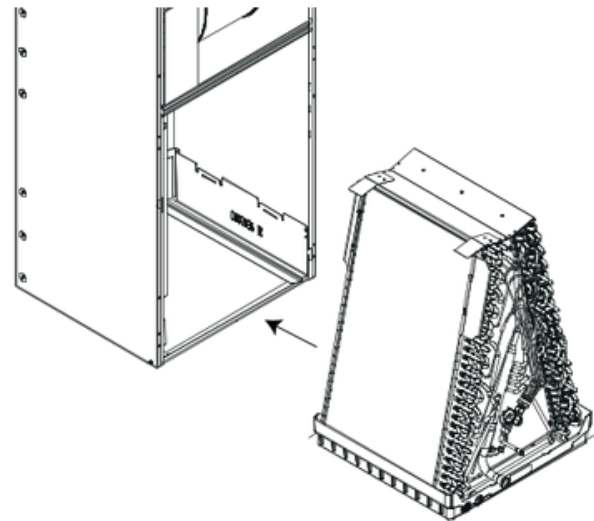

16. Replace all panels.

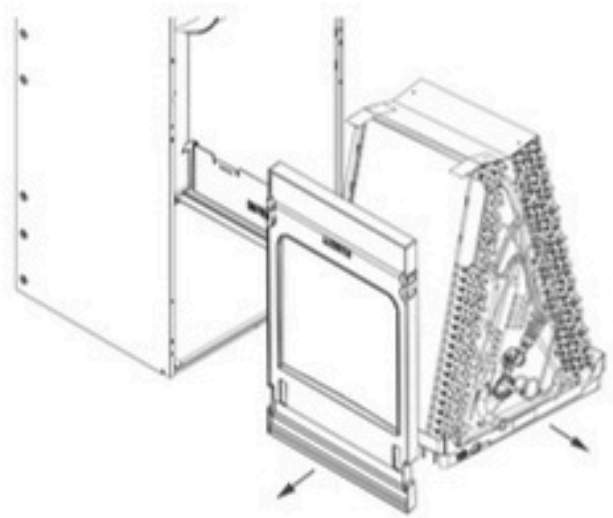
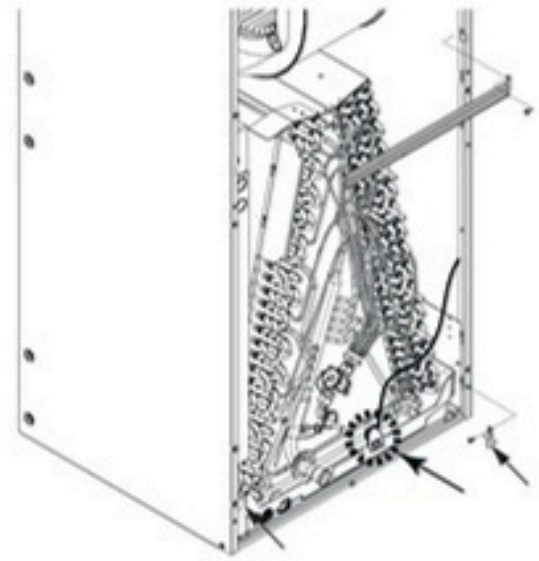
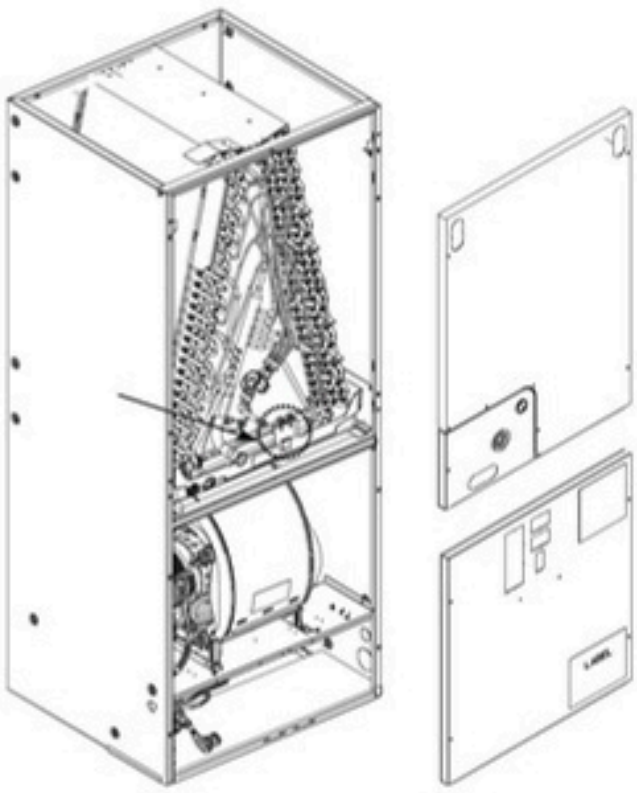

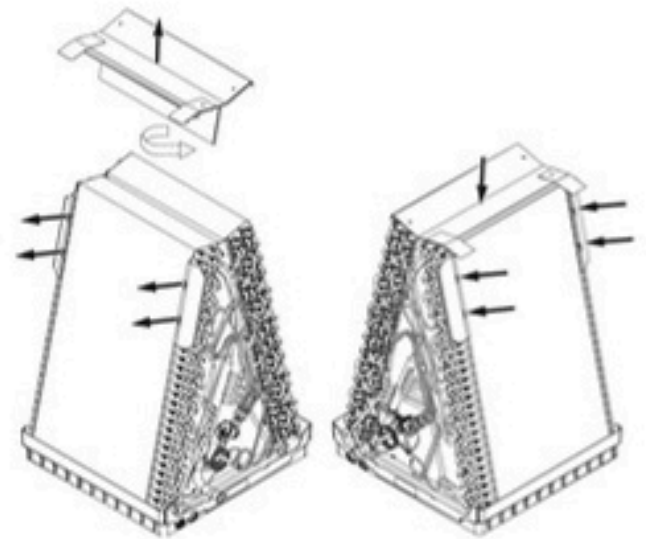

Remove 2 screws
and water diverter
bracket

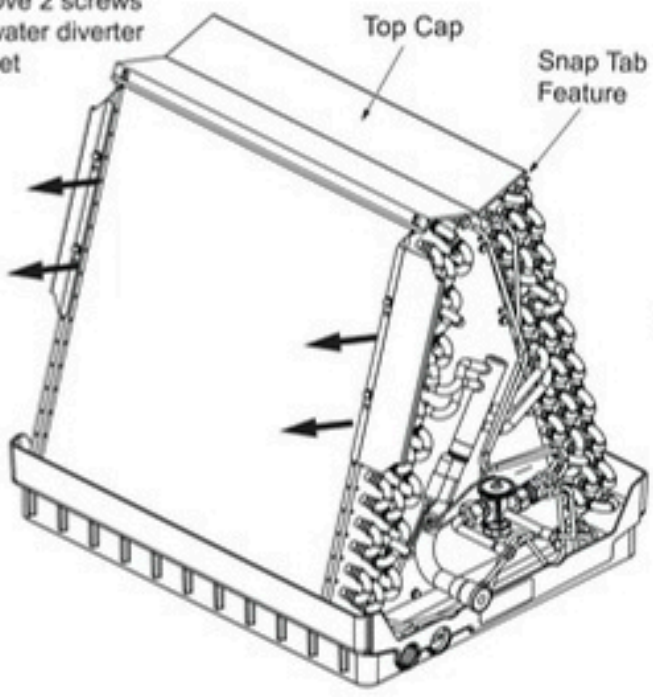

Replace 2 screws
and water diverter
bracket

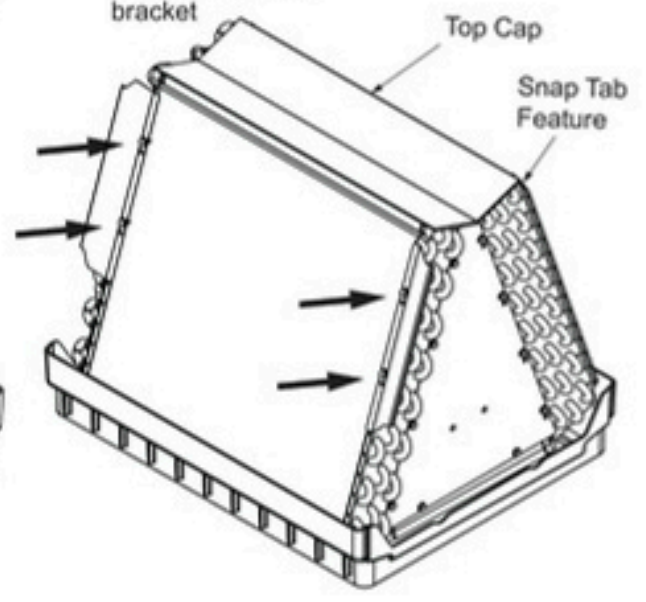
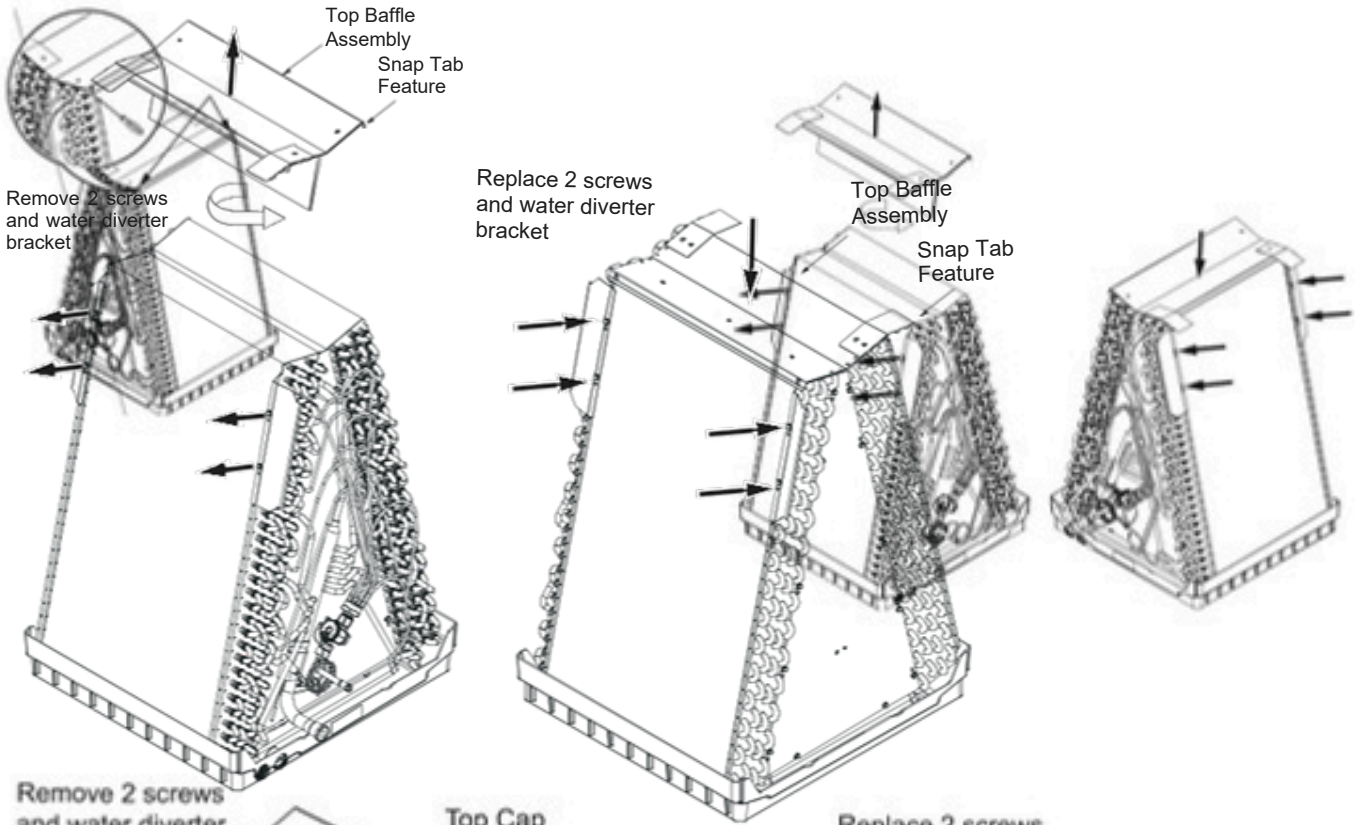

Figure 36. 5TEM4D06 and D07 horizontal right coil conversion



11. To allow the horizontal pan to slide in on the right, cut and remove the zip tie holding the sensor wire harness on the right side of the coil cabinet.
12. Relocate the horizontal drain pan from the left side of the coil to the right side.
13. Remove the drain pan support bracket. Do not discard. Remove the two drain plugs from the front of the drain pan and insert them in the drains at the rear of the drain pan.

Important: When reinstalling coil in [Step 17](#), it is important that the coil corner locks in place under the rear tab in the side bracket to support the coil weight horizontally. There are two additional tabs for added support.

Figure 37. Coil assembly and horizontal drain pan

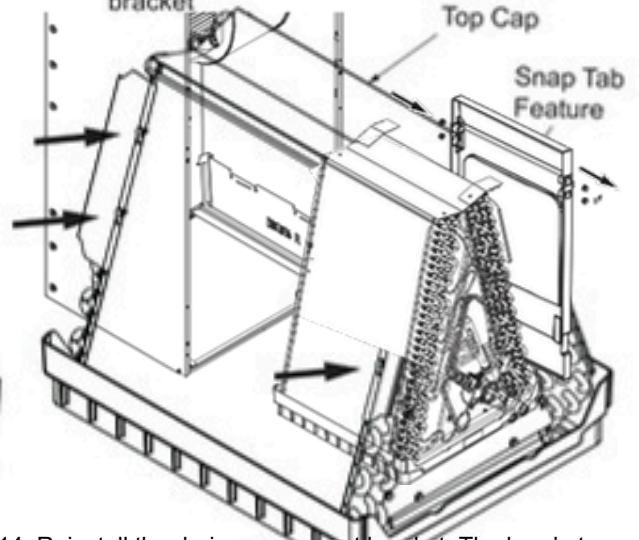

14. Reinstall the drain pan support bracket. The bracket should be located between the two drain plugs as shown.

Figure 38. Drain pan support bracket

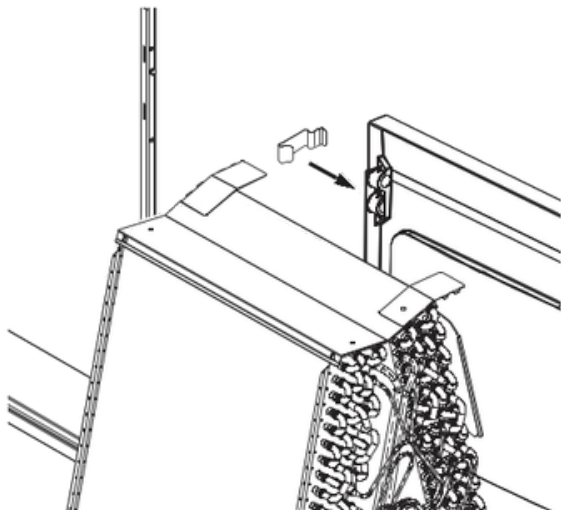

15. Proceed to [Step 16](#), if using coil support brackets as shown in [Figure 40](#), p. 37. Proceed to [Step 17](#), if using coil support brackets in [Figure 39](#), p. 37.

Figure 39. Coil support brackets

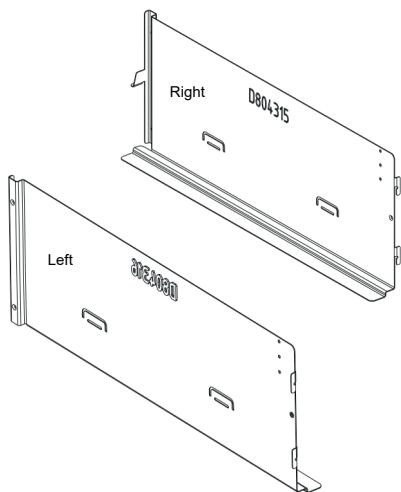
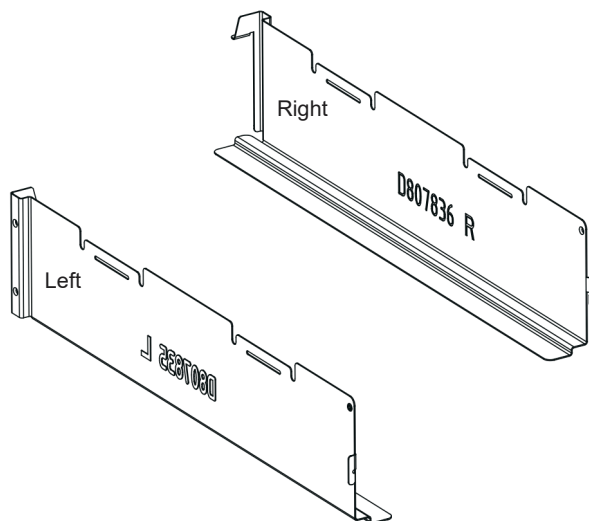
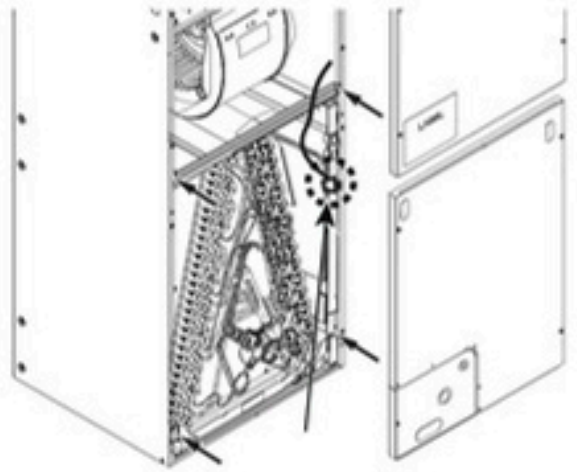
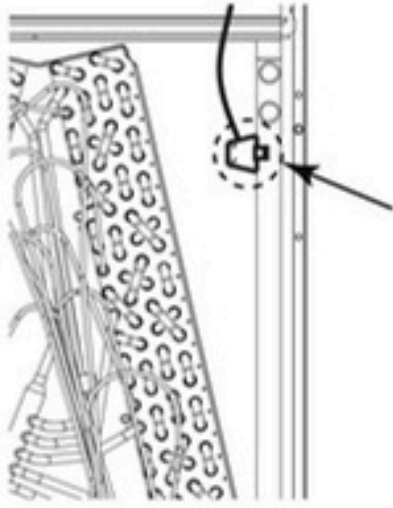

Figure 40. Coil Support Brackets with two large tabs



16. Bend the two tabs on the left coil support bracket. Tabs should be bent inward so they are parallel to the bottom flange.
17. Slide the coil assembly back into the air handler cabinet.
- Important:** Make sure that the coil corner locks in place under the rear tab and two additional tabs along the length of the drain pan in the side left bracket to support the coil weight in the horizontal right position.
18. Replace the center horizontal bracket using screws removed earlier in [Step 3](#).
19. Replace the two coil retaining brackets removed in a previous step.
20. Rotate unit into horizontal right position.
21. Install sensor onto secondary drain pan using the provided clip. Sensor should be positioned close to the drain lines. Reconnect the sensor to the wire harness and position extra wire length in the drain pan.



Checkout Procedures

The final phase of the installation is the system Checkout Procedures. The following list represents the most common items covered in a Checkout Procedure. Confirm all requirements in this document have been met.

- All wiring connections are tight and properly secured.
- Voltage and running current are within limits.
- All refrigerant lines (internal and external to equipment) are isolated, secure, and not in direct contact with each other or structure.
- All brazed connections have been checked for leaks. A vacuum of 350 microns provides confirmation that the refrigeration system is leak free and dry.
- If unit is installed in any orientation other than upflow, refrigerant sensor is properly relocated.
- Final unit inspection to confirm factory tubing has not shifted during shipment. Adjust tubing if necessary so tubes do not rub against each other or any component when unit runs.
- Ductwork is sealed and insulated.

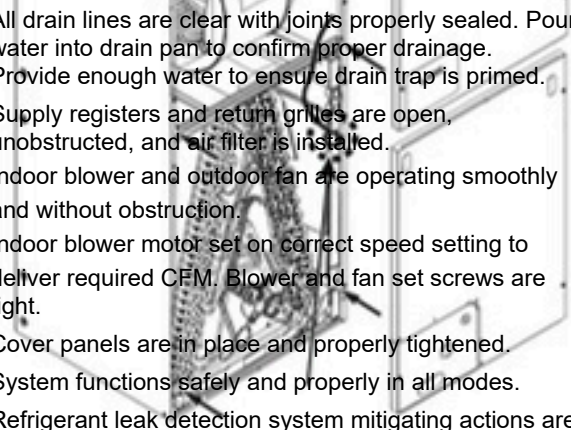
- 
- All drain lines are clear with joints properly sealed. Pour water into drain pan to confirm proper drainage. Provide enough water to ensure drain trap is primed.
 - Supply registers and return grilles are open, unobstructed, and air filter is installed.
 - Indoor blower and outdoor fan are operating smoothly and without obstruction.
 - Indoor blower motor set on correct speed setting to deliver required CFM. Blower and fan set screws are tight.
 - Cover panels are in place and properly tightened.
 - System functions safely and properly in all modes.
 - Refrigerant leak detection system mitigating actions are verified.
 - All refrigerant safety procedures have been verified.
 - Owner has been instructed on use of system and given manual.

About Trane and American Standard Heating and Air Conditioning

Trane and American Standard create comfortable, energy efficient indoor environments for residential applications. For more information, please visit www.trane.com or www.americanstandardair.com.

The manufacturer has a policy of continuous data improvement and it reserves the right to change design and specifications without notice. We are committed to using environmentally conscious print practices.

AHR-SVX003C-EN 21 Mar 2026

Supersedes AHR-SVX003B-EN (November 2025)

©2026